

**Admiral Robert E. Kramek, USCG  
Commandant**

*The Marine Safety Council of the  
United States Coast Guard*

Rear Admiral Paul M. Blayney, USCG  
Chief Counsel, Chairman

Rear Admiral James C. Card, USCG  
Chief, Marine Safety and Environmental  
Protection Directorate, Member

Rear Admiral Edward J. Barrett, USCG  
Chief, Office of Engineering, Logistics and  
Development, Member

Rear Admiral Rudy K. Peschel, USCG  
Chief, Office of Navigation Safety and  
Waterway Services, Member

CDR Stephen J. Darmody, USCG  
Executive Secretary

Cheryl Robinson  
Editor

Karlin Gray  
Graphic Designer

*Proceedings* (ISSN 0364-0981) is published quarterly by the Coast Guard's Marine Safety and Environmental Protection Directorate, in the interest of safety at sea under the auspices of the Marine Safety Council. The Secretary of the Department of Transportation has determined that the publication of this periodical is necessary in the transaction of the public business required by law of this agency. Special permission for republication, either in whole or in part, except for copyrighted material, is not required, provided credit is given to *Proceedings*. The views expressed are those of the authors and do not represent official Coast Guard policy.

#### POINTS OF CONTACT

Cheryl Robinson, Editor  
Voice: (703) 235-1604  
Fax: (703) 235-1062  
E-mail: Cheryl\_Robinson/NMC@CGSMTP.USCG.MIL  
World Wide Web:  
<http://www.dot.gov/dotinfo/uscg/hq/g-m/gmhome.htm>

All requests for subscriptions and changes of address must be in writing, addressed to: Editor, *Proceedings Magazine*, U.S. Coast Guard National Maritime Center, 4200 Wilson Boulevard, Suite 510, Arlington, Virginia 22203-1804. Please include mailing label when changing an address.

DIST (SDL No. 134)  
A: ac(2); ebfghijklmnopqrsuv(1).  
B: nr(50); cefgipw(10); bklqshj(5); xdmou(2); vyz(1).  
C: n(4); adek(3); blo(2); cfgijmpqrtuvwxyz(1).  
D: ds(5); abcefgghijklmnopqrtuvwxyz(1).  
E: kn(2), F: abcdehjkloqst(1).  
List TCG-06.

Our 53rd Year

# Proceedings

of the Marine Safety Council

July-September, 1996 Vol. 53, No. 3

## How Technology is Affecting the Maritime World

### Features

<b>How Technology Is Affecting The Maritime World .....</b>	<b>4</b>
<b>Maritime Technology in the San Francisco Bay Region .....</b>	<b>6</b>
<b>American Bureau of Shipping SafeHull 96 Brings Significant Technology Developments .....</b>	<b>16</b>
<b>Out of the Fog .....</b>	<b>20</b>
<b>Sharing Coast Guard Information Via the Port State Information Exchange System (PSIX) .....</b>	<b>26</b>
<b>Controlling Microorganisms in Diesel Fuel A New Solution to an Old Problem .....</b>	<b>28</b>
<b>Ship Structural Integrity Information System (SSIIS) .....</b>	<b>31</b>
<b>Realizing the Promise of Automation Through Better Design and Training .....</b>	<b>36</b>
<b>Taking the Search Out of Marine Safety .....</b>	<b>39</b>
<b>Technology and Maritime Professionals Proactively Reduce Navigational Risks on Southeast Texas Waterways .....</b>	<b>43</b>
<b>USCG R&amp;D Center Conducts Research in Tactical Oil Spill Surveillance Technology .....</b>	<b>53</b>
<b>PTP at Work .....</b>	<b>58</b>
<b>Simulation Training to Meet Advances in Shipboard Automation .....</b>	<b>62</b>

### Departments

<b>RADM Card Speaks .....</b>	<b>2</b>
<b>By the Way .....</b>	<b>3</b>
<b>Mariner's Seabag .....</b>	<b>66</b>
<b>Nautical Queries .....</b>	<b>68</b>
<b>Investigator's Corner .....</b>	<b>70</b>

---

## RADM CARD SPEAKS . . .

By Rear Admiral James C. Card,  
United States Coast Guard

# Technology And The Times



“Beam me up, Scotty.” Once upon a time, not too many years ago, futuristic and science-fiction fantasies seemed just that. Times have changed. These days our world is filled with on-line networks & nationwide pagers, around-the-clock cable & cellular phones, modems & voice mail, and the Internet & the World Wide Web. While we may not have electronic transport (yet), the lines between present reality and future fantasy have become less defined.

Just as information is increasingly viewed as a tangible resource (similar to raw materials, human resources and fixed assets), it naturally follows that – more than ever – decision makers need a thorough knowledge of available technologies. Evidence of this exists worldwide, where we see the creation of Chief Information Officer positions in many corporate boardrooms, and in the Coast Guard’s Marine Safety and Environmental Program, with establishment of the Office of Information Resources (G-MRI).

Throughout our history, the Coast Guard (USCG) has consistently embraced the use of pioneering technologies. Through creation of the Marine Safety Information System, the Port Safety Information Exchange, and continued development of cutting-edge technologies (e.g., the Marine Safety Network and the USCG Web

Site on the Internet), we continue to seek better and more efficient ways to operate amid a shrinking federal budget.

One such example of this new “applied technology” involves planning and response activities at our field units, where the Coast Guard’s Spill Planning and Response System; Global Positioning System and Forward-Looking Infrared Radar have afforded an increasing array of tools to local field commanders in meeting their goals for our Business Plan. This “storehouse” of information has also provided the necessary statistical base to implement an effective Prevention-Through-People campaign for reducing human error in marine casualties.

In short, timely and accurate information has become an integral part of our efforts in: fiscal/operational planning, prevention, training, casualty analysis, policy-making and regulatory development. Our business, like yours, requires much planning, flexibility and responsiveness. A concerted and effective use of technology will continue to prove invaluable in meeting the demands of a global market, all-the-while ensuring a safe and environmentally-sound maritime workplace.



---

# BY THE WAY...

## Editor's Point of View

Cheryl Robinson

*Proceedings* magazine continues to keep you informed about all aspects of the maritime industry. Our theme for this issue is “How Technology Is Affecting The Maritime World.”

Today, as we approach the twenty-first century, our nation's ship and shore infrastructure has the broadest spectrum of advanced technology in equipment and techniques for virtually all aspects of the shipping industry. This technology includes—but is not limited to—computer systems for monitoring, sampling and testing; innovative use to control marine fuels, engine use and technology; identifying safety hazards and environmental pollution prevention; maintaining port safety; and the search and rescue effort. These technological advancements that we

often take for granted are responsible for helping the maritime community to maintain its global competitiveness.

Coast Guard members are prepared to perform any mission, anytime, anywhere. Some of these technological advancements help increase the Coast Guard's ability to perform their mission.

Our staff hopes you will receive some new information and useful ideas from this issue. If you have any topics you would like to see in upcoming issues, send in your idea and we will do the rest. Suggested themes are only limited by your imagination.

Again, a special thank you to all our readers!



**Next Issue:**  
**“Electronic Commerce in the Maritime Community”**

**Upcoming Issues:**  
**“Safety Through Shared Lessons Learned”**  
**Partnerships/Alternate Compliance”**

---

# How Technology Is Affecting The Maritime World

By Captain Robert G. Ross, USCG  
Chief, Office of Information Resources

The theme of this issue, "How Technology Is Affecting the Maritime World," is both timely and timeless. It is timely because we now possess astounding potential to improve the way we do things by taking advantage of new developments in engineering, increasing capabilities in electronics and information processing, and new thinking about the people-based problems which face the maritime community. But it is also timeless because any history of mankind's involvement with the sea is necessarily a history of new technology and new ways of doing things. Indeed, technological change has been one of the few constants in the long history of going to sea.

The purpose of this issue is to present a number of ideas, to provide a sampler if you will, on new technology and new techniques that are being pursued by various players in the maritime community. There is no expectation that the articles in this issue will be representative, much less inclusive, of all of the new technology and new thinking which is out there. Rather, the hope is that readers will be encouraged by the promise of the techniques or products described here to look at ways they can take advantage of new technology and techniques in solving their own problems.

Some of these ideas, such as the ABS SafeHull program, involve harnessing the power of computers to improve ship design in ways which were impossible just a few short years ago. Others involve using the information storage and retrieval capability of modern information processing systems to better perform tasks, such as ship maintenance and navigation, which have been with us for generations. For example, real-time availability of accurate information on tides, currents and approaching traffic have the potential to significantly improve pilotage and reduce risk during in-port transits. Another article describes an "out of the box" approach for dealing with micro-organisms in marine fuels. This article is offered, not as an endorsement for the product, but rather as an example of the kind of shift in thinking which may be the key to being able to tackle old problems in new ways.

Having touted the potential for new technology and new techniques, however, it is time to sound a

warning bell. The introduction of new technology, if not done carefully, carries with it significant risk. Take, for instance, radar. The introduction of this powerful collision avoidance tool was followed shortly thereafter by a new phrase in the nautical vernacular: "radar assisted collision." How long now before we are talking about, "electronic navigation assisted groundings" without even appreciating the irony of what we are saying?

Recognizing the potential for pitfalls in careless introduction of new technology is the first step in reducing it, and two articles in this general area are offered for consideration. The first, from the Coast Guard's Research and Development Center, discusses some of the mental ergonomics and logic traps which can result from poor screen design and/ or inadequate



---

operator training for systems such as electronic charts. The second discusses the use of new technology, simulator technology in this case, to effectively train operators in the proper use of other new technology and equipment before they see it in the real world – and before a casualty tells us we got it wrong.

There is another aspect to the proper introduction of new technology which centers on the adoption of appropriate national and international standards and policies on the design and use of new technology. One such area involves the technical, functional and performance standards which a true ECDIS (Electronic Chart Display and Information System) will have to meet. Another is “solo bridge watch” where the questions of “**Where?**,” “**When?**” and “**How?**,” not to mention the most fundamental question of all, “**Should we ever...?**,” have not yet been answered to everyone’s satisfaction. Unfortunately,

we do not have an article addressing either the “solo bridge watch” issue or the closely related topic of “Integrated Bridge Systems,” but “*Out of the Fog*” provides a good primer on the many unanswered ECDIS questions. Similar unresolved issues surround many of the capabilities which new technology might give us. Unanswered, these questions may keep us from realizing many of the potential benefits which the new technology offers

Today, as throughout history, perceptions of risk and opportunity in the maritime world are creating demands for innovative solutions and new technologies. How well we, industry and government working together, take advantage of the promise inherent in these new technologies and techniques will, to a large extent, determine the future health of the maritime world.



---

# Maritime Technology in the San Francisco Bay Region

by LCDR Pete Marsh, USCG and CAPT Thomas Richards, NOAA, with contributions by various agencies mentioned.

## INTRODUCTION: THE HISTORICAL PERSPECTIVE

Several maritime technology initiatives are currently underway in the San Francisco Bay Region, continuing a San Francisco trend as an early adopter of technology. After all, Telegraph Hill got its name because it was the vantage point from which observers could read signals about arriving ships from semaphore telegraphs further west at Point Lobos and the Presidio, and relay them to the waterfront. The semaphore system was used from 1850 until it was replaced in 1853 by the first electric telegraph line on the West Coast, carrying signals from the Point Lobos lookout directly to the Merchant's Exchange office on Sacramento Street. In 1876, the year the telephone was invented by Alexander Graham Bell, the Merchant's Exchange installed an experimental line. In the late 1940s, a shoreside radar was installed for ship tracking. And in 1972, the Coast Guard opened the nation's first Vessel Traffic Service in San Francisco.

Many of the innovations taking place in the San Francisco Bay Area today will help shape the character of marine commerce for decades to come, just as their predecessors did before them. The following article describes a few of the initiatives currently in progress.

- The U.S. Coast Guard is upgrading the San Francisco Vessel Traffic Service.
- The Coast Guard has just declared Initial Operational Capability for the nationwide Differential Global Positioning System (DGPS).
- The National Oceanic and Atmospheric Administration (NOAA) and a Bay Area coalition, are developing the Physical Oceanographic Real Time System (PORTS). This project in turn, is linking numerous other projects, including hydrodynamic flow modeling by the US Geological, Survey.
- The San Francisco Bar Pilots are testing Portable Pilot Units (PPU), as part of a grant from MARAD to the American Pilots Association.
- The Marine Exchange of the San Francisco Bay Region is spearheading a cooperative project

called Marine Information Service of North America (MISNA).

- NOAA is developing hybrid electronic charts, a combination of raster and vector technologies, with their prototype data set targeted for San Francisco.
- The Port of Stockton uses a variety of surveillance and communications equipment to monitor cargo loading operations and security.
- NOAA and the Corps of Engineers are conducting experiments with detecting ship squat in real time using DGPS in three dimensions.
- Private sector firms are investigating the possibility of creating their own extremely high-resolution digital chart data sets near their piers for use by docking masters.

While many of these projects are separately funded and managed, the numerous entities involved are also cooperating, through such venues as the Harbor Safety Committee, in order to implement the projects in such a way that all can benefit. First, we'll describe each of the projects individually, then describe the ways in which they enhance each other.

## VESSEL TRAFFIC SERVICE UPGRADE (VTS UPGRADE)

by LCDR Pete Marsh, USCG VTS San Francisco

This project is being undertaken by the U. S. Coast Guard to improve VTS capabilities. The Coast Guard operates eight VTSSs, and the Upgrade project is being implemented in four of them: New York, Puget Sound, San Francisco, and Houston/Galveston.

Current technology in these VTSSs consists of VHF radio, radar displays, and television cameras. The radar displays incorporate Automatic Radar Plotting Aids (ARPA) to assist the operator in tracking vessel movements and in assessing potential collision

situations. These movements are recorded on paper cards, which are moved around on a desktop to represent the positions of vessels on the radar screen.

VTS Upgrade adds electronic charts, more sophisticated tracking and alarms to this mix, and replaces the paper Vessel Data Cards with a computer database. The Upgrade system is operational at VTS New York and VTS Puget Sound. Installation at San Francisco is complete, and crew training is in progress. The system should be operational in early 1997.

Using electronic charts as the display basis rather than raw radar video gives the operator a greatly improved georeferenced picture. Radar video is overlaid on the electronic chart, but land areas are normally masked out, thereby eliminating non-maritime targets, allowing the operator to concentrate on potential vessel interactions more than on tracking individual vessels.

Data management is also improved. The Upgrade system incorporates a relational database of vessels, facilities, anchorages, standard routes, and transit

histories. It provides in-depth statistical analysis capabilities, which will become critical as competition for waterway use increases.

Console ergonomics and workload management are substantially improved. The video cameras are integrated into the console, with controls at the operator's fingertips. Radio and telephone control are integrated into a single, compact touch panel instead of a large, dedicated rack. Perhaps most significantly for workload management, any console can display chart and radar data from any or all parts of the VTS area. In the past, one of the biggest limitations was that each remote radar site required a complete display console. VTS Upgrade allows data from multiple radar sites to be displayed on a single console, allowing better surveillance and better workload management. A single operator could handle several geographic areas if traffic load were light. Conversely, multiple operators could be assigned to certain areas if the traffic load became heavy.

*Continued*



## DIFFERENTIAL GLOBAL POSITIONING SYSTEM (DGPS)

by LCDR Pete Marsh, USCG VTS San Francisco

Many of the projects described in this article would not be possible without another technical innovation just brought online by the Coast Guard, the DGPS system. DGPS enhances "regular" GPS by building reference stations every two hundred miles or so around the coast. These stations are surveyed in with centimeter accuracy, and constantly compare their own known position to the position they receive from the GPS satellites. They then calculate the position error, and transmit that "differential" vector over existing radiobeacon frequencies. Mobile differential receivers then apply the differential to their own satellite position. Through this scheme, standard GPS accuracy of 100 meters is improved to 5 or 10 meters. The difference is critical for large ship navigation in constricted waterways; many of the channels in San Francisco Bay, and indeed, nationwide, are less than

100 meters wide! So that level of error is clearly unacceptable for harbor navigation.

## PHYSICAL OCEANOGRAPHIC REAL TIME SYSTEM (PORTS)

by CAPT Thomas Richards, NOAA

The National Oceanic and Atmospheric Administration has selected San Francisco Bay as its primary regional site to demonstrate how a number of National Ocean Service technologies and information databases can work together to improve the safety and efficiency of maritime commerce while at the same time providing tools for coastal zone management. NOAA's Physical Oceanography Real time System (PORTS) clearly demonstrates this capability. Real time currents, water levels, and wind conditions which PORTS is designed to provide are critical parameters to safe navigation of ships within San Francisco Bay. At the same time the real-time water level information gathered

*VTS upgrade screen print*

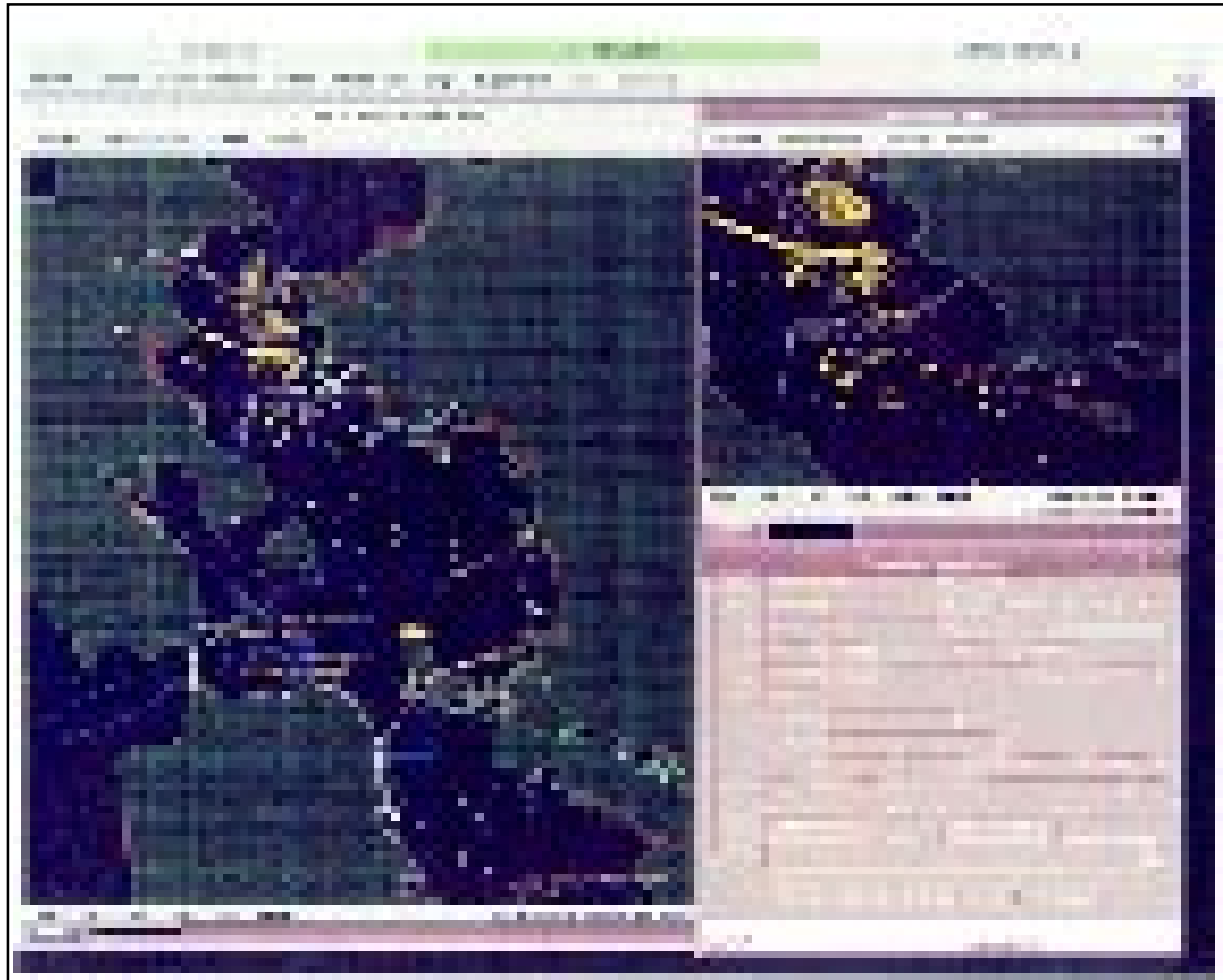



*PORTS sensor locations*



by PORTS allows shipping companies to improve the loading of ships entering and leaving harbor. The physical parameters gathered by PORTS are readily available to coastal managers in monitoring conditions such as salinity in the estuary and in developing plans for in-bay hazardous materials spill response.

The basic design for PORTS in San Francisco Bay consists of real time sensors for water level, current, salinity, and wind. These sensors are located at strategic points throughout the bay as depicted on the map above. Each sensor site uses a real-time telemetry link to a computer data acquisition system, and an information hub located ashore.

Even though PORTS is not yet fully on-line, mariners in San Francisco Bay region have already begun using PORTS data to improve the safety and efficiency of commercial shipping transits. Primary among the early adopters are the San Francisco Bar Pilots. Many of the pilots routinely query the system via computer modem from home or the office prior to

vessel transits, or call the system's voice response unit via cellular phone while in transit. In time, laptop electronic chart systems carried aboard ships by the pilots, or integrated bridge systems being installed on many oil tankers will incorporate PORTS data real-time and provide nowcasts and forecasts of conditions the ship is expected to encounter while enroute through the bay. Knowing the magnitude of the current near Oakland, prior to entry into the restricted approach channel has long been a need of the pilots maneuvering huge container ships past the Seventh Street terminal. This information is now readily available.

One container shipping company has already reported saving thousands of dollars by using real-time water level data to be able to remain alongside, offloading containers longer than predicted tide levels ordinarily would have allowed. Pilots transiting under the Southern Pacific Bridge are able to better predict air-draft clearances under the bridge and defer unnecessary ballasting. Tankers using tug escort in the

*Continued*

bay will use information from PORTS when revised regulations are put in place next year to ensure that the proper tug to ship matching is planned for specific current conditions. Current conditions are already readily available to vessels maneuvering in Carquinez Strait, near the Richmond Long Wharf, and departing Richmond Inner Harbor.

Scientists studying current modeling in San Francisco Bay, such as USGS's Ralph Cheng in Menlo Park, California and Jerry Galt at NOAA's Hazmat office in Seattle, Washington are using data from the sensors to improve existing current models for the bay. They are working with the California Office of Oil Spill Prevention and Response to improve trajectory modeling in case of a hazardous material spill in San Francisco Bay. Geographic Information System researchers at UC Berkeley, under a grant from the San Francisco Bay Conservation and Development Commission, and scientists at the San Francisco Estuary Institute are studying ways to make data and information more readily available to coastal zone management officials throughout the region. The salinity sensors in Carquinez Strait and in Honker and Grizzly Bays are contributing along with the efforts of many other agencies to better understanding of the fresh and salt water supply in the Delta region of the bay.

## CURRENT PATTERN ANALYSIS

by LCDR Pete Marsh, USCG, with contributions by Dr. Ralph Cheng, USGS

The U. S. Geological Survey conducts detailed research in water resource management nationwide, and San Francisco Bay is no exception. Anyone familiar with water-use issues in the West will recognize the value inherent in better understanding of the water flow picture in the San Francisco Bay Area. At the USGS office in Menlo Park, Dr. Ralph Cheng has been working for years on detailed hydrodynamic models of San Francisco Bay. His project is endorsed by several Federal and California State agencies and San Francisco Bay organizations. One of the objectives of Dr. Cheng's Project is to enhance oil spill response capability and to increase safety and economic benefits of maritime commerce in San Francisco Bay.

Now with the real-time data from PORTS, Dr. Cheng is able to (a) validate his model much more thoroughly, (b) make his model results available real-time on the Internet, and (c) make his model available for public use, but with his model results cross-checked by the real-time observations. Since the PORTS data are fed into the model every six minutes, the

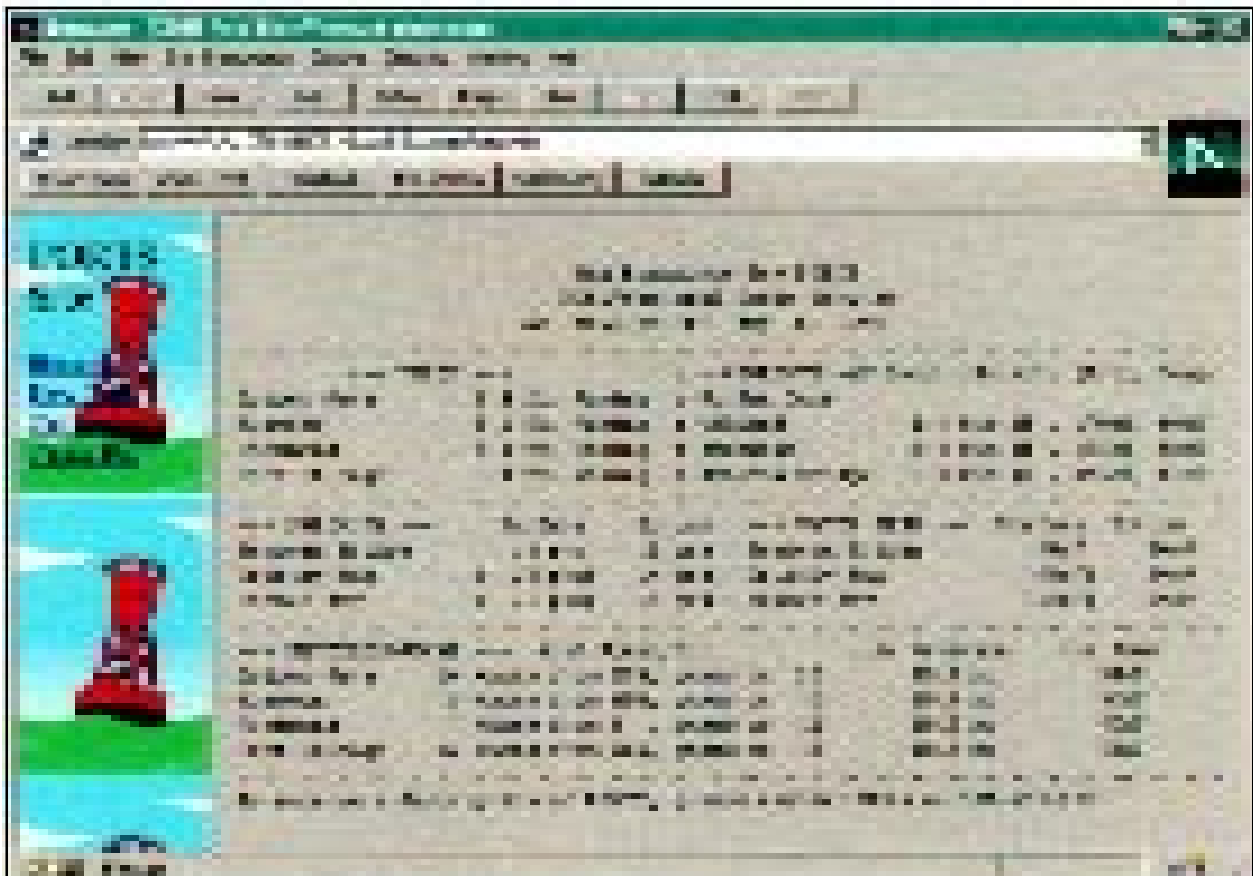

PORTS data screen print

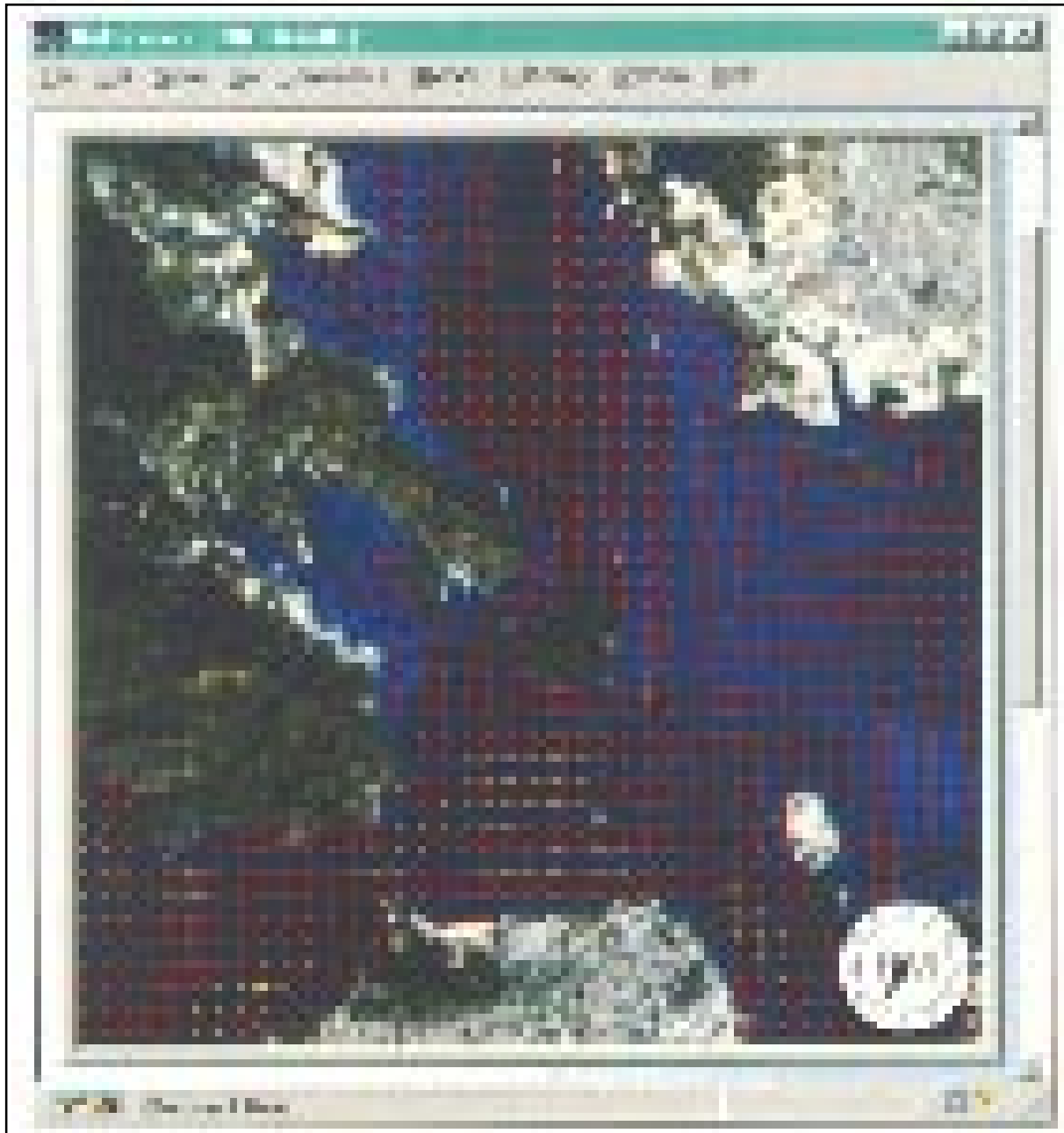

model is constantly being corrected for actual conditions, thus providing highly accurate short-term predictions for tides and currents in the rest to the Bay.

The combinations of real-time observations and model predictions are invaluable for pilots as they navigate the restricted channels of San Francisco Bay, and likewise for water managers in the region. How much fresh water must we let through to the critical estuaries in Carquinez Strait and just east? How much should we use for agriculture in the Central Valley? Residential and industrial use in the Bay Area? What about some for Southern California? Real-time observations of salinity, temperature and current provide invaluable data for

managing this most vital resource, which is largely taken for granted.

### **PORTABLE PILOT UNIT (PPU)**

by LCDR Pete Marsh, USCG, with contribution by Captain Carl Bowler, SF Bar Pilots

The San Francisco Bar Pilots (SFBP) is one of ten regional pilot's organizations around the country participating in an evaluation of Portable Pilot Units.

*Continued*

The evaluation project is sponsored by the American Pilots Association's Navigation Technical Committee, and funded by MARAD. The goal is to examine the utility of portable technology in assisting their ship piloting efforts.

A Portable Pilot Unit combines three cutting edge systems into a single portable unit. The first is an Electronic Chart System (ECS); the second is DGPS (see above); and the third is Automated Dependent Surveillance (ADS). The DGPS receiver provides highly accurate position input to the ECS, thus enabling very precise own-ship navigation. The radio transceiver then sends the ship's identity, position course, and speed to a central site, which plots their position. This part is what constitutes ADS: *automated surveillance, dependent on the ship for position input.*

With all the talk about smart bridges, most of us have already heard about ECS, its "big brother," ECDIS, and ADS. However, the challenge in the PPU project is literally getting all that "stuff" in a ten pound bag. The PPU equipment package combines the ECS, DGPS, and ADS into a single backpack style unit weighing exactly 13 pounds.

More and more ships are now starting to carry ECDIS and ADS systems, and carriage requirements will inevitably evolve to mandate these for the rest. In this environment, why are the pilot organizations interested in carrying their own aboard? Primarily for reasons similar to why they almost universally carry their own portable radios aboard: shipboard systems may be unfamiliar and therefore difficult to operate; they may be inconveniently located on the bridge- or they may be poorly maintained. By bringing PPU aboard, the pilot brings familiarity, reliability, and ease of use. The PPU can also serve as a repository, ready reference, and visual representation for the vast store of knowledge a pilot maintains. The question is whether such a system can deliver sufficient functionality in a small enough form factor to enhance safety of navigation without detracting from safety of the boarding process!

Equipment from several manufacturers is being tested in the different regional organizations. The project's goal is not to declare a single equipment set as the best PPU, but to examine the maturity of the component technologies and work with numerous vendors to design several packages which would be practical to carry aboard.

## MARINE INFORMATION SERVICE OF NORTH AMERICA (MISNA)

by Roger L. Peters, Board of Directors,  
Marine Exchange of the San Francisco Bay Region

The Marine Exchange of the San Francisco Bay Region and its sister exchanges in Los Angeles/Long Beach, Portland, Seattle, and Vancouver, B.C. have recently formed a new nonprofit corporation: Marine Information Service of North America. Its stated purposes are to promote maritime safety and efficiency through the facilitation, flow, and utility of information, through the dissemination of marine information to parties interested in maritime affairs, and to assist the maritime industry and, various government agencies in the implementation and preservation of vessel traffic and other navigational safety systems.

Each exchange currently provides local information to their community-based memberships. By joining together, each exchange will provide real-time estimated and actual arrival and departure information for vessels anywhere on the coast. This wider range of available information will clearly improve the efficiency of each port's operations. In addition, this wider range of coverage will provide regulatory authorities with better control tools in monitoring regulated vessel movements. The exchanges intend to provide this information to customers by telephone, fax, and through on-line Internet PC applications.

In addition to operations reporting, the combined data will enable MISNA to provide special reports and consulting services. Examples of these services include market analysis, competition research, transit-time evaluations, capacity reviews, historical inquiries, port utilization reports and harbor services studies.

MISNA is still in its formative and developmental phase – marketing strategies, data maintenance and organizational structure options are still being reviewed. Expansion of its membership to include additional port regions is being evaluated. MISNA is also investigating potential strategic partnerships with government promotional and regulatory agencies as with complementary private-sector information vendors.

---

## HYBRID ELECTRONIC CHARTS

contributed by David Enabnit, NOAA

NOAA is developing another San Francisco first—the first prototype of their new hybrid electronic chart covers the San Francisco Bay Region. The hybrid electronic charts are a combination of raster and vector technologies, a step on the road to complete digital data required by the International Maritime Organizations DX-90 electronic chart requirements. NOAA's National Ocean Service (NOS) has been working on gathering standards compliant digital data for several years. Experience has shown that the required exhaustive collection of data on the nautical charts is far beyond the level of available resources. However, it is still the belief in NOS that, when used with differential GPS for positioning, electronic navigation systems will be the most significant improvement to marine navigation since radar. It is therefore incumbent on NOS to produce data to support this improvement to the best of its ability.

Since the exhaustive digital collection of all charts is unaffordable, NOAA has proposed that a reduced set of the most navigationally significant data be gathered and made available in digital form. This reduced data set ("limited vector themes") would then be overlaid on a background consisting of NOS raster nautical charts, depicting the shoreline, depths, landmarks and other inshore information. The raster chart would be used concurrently with the vector data for general navigation information in the surrounding area. This combination would still provide many benefits to an important subset of the marine navigation community yet be within the resources available to NOS. The reduced data set would be standards-compliant except for its reduced content.

Commercial mariners would use the electronic data for real-time navigation and for collision and grounding avoidance—particularly in times of limited visibility. Shippers could augment NOS' data with ultra-high precision DGPS private surveys of their piers to allow all-weather docking on instruments alone.

The data in this reduced-ECDIS would be that high value data most important for commercial shipping, and for navy ships transiting to and from home ports. Data would be provided only in an around shipping routes and would not be suitable for general navigation by the public-at-large such as recreational boaters. It would also not be suitable for large-scale naval operations nor as a coastal zone management tool.

---

### The data themes selected are:

- aids to navigation
- anchorages
- bridges
- cables
- offshore platforms
- precautionary and restricted areas
- traffic separation schemes
- channels and dredged areas wrecks and obstructions
- depth curves
- pipelines

### The vector data set will have the following characteristics:

- very large scale (1:2,500)
- DGPS accuracy
- current to within one week at all times
- only available as an electronic product and only available electronically
- expandable with private data
- updatable with real-time tides and currents

---

The prototype hybrid charts were delivered in February 1996. These charts will be used by local mariners and software developers to test the theme selection, to develop software and to test electronic distribution methods.

## PORT OF STOCKTON TECHNOLOGY

contributed by Mark Tollini, Port of Stockton

The Port of Stockton, located 75 miles inland from San Francisco Bay, is a medium size river port preparing itself to cross the threshold into the next millennium. Although small in size compared to port facilities such as Oakland or Los Angeles/Long Beach, the Port of Stockton looms large in its application of modem technology utilized to conduct day-to-day operations.

Foremost in importance to Port staff are five remotely operated television cameras strategically located on Port grounds. These Sanyo CCD color cameras, equipped with auto iris zoom lenses, are fully enclosed for protection against weather and are slaved to a Pelco pan-and tilt control mechanism. Real time images are transmitted to eight locations within the Port's administration building via a fiber optic link

*Continued*

capable of handling a total of thirty-two cameras, thereby ensuring adequate capacity for future additions should the need arise. Two cameras, mounted atop water towers, provide for a panoramic 360-degree bird's eye view of the entire Port area. Three other cameras are mounted at specific dockside locations, providing Port staff with an up-close perspective of vessel cargo operations and terminal activities.

Initially, one camera was mounted at Berth #30 to assist Port Operations in monitoring stevedore operations being conducted at that pier. Aside from the obvious benefit of being able to view real-time activities from an off-dock location, the response of Port customers to this new innovation was overwhelmingly positive. Prospective Port customers are now treated to an armchair tour of the Port of Stockton's facilities while sitting in the comfort of the Port Director's office.

Additionally, the camera system has been integrated into the Port's Central Emergency Response Communications Control Center. The Control Center features three television monitors, camera selectors and controllers, a centralized VHF radio bank featuring all major Port frequencies, and includes telephone patch capability. Real-time data in the form of wind speed, wind direction, rainfall rate, and 24-hour cumulative rainfall totals, as well as current tide readings are superimposed onto the corner of the screen of selected television monitors. A sixth camera transmits images from a Furuno radar with tracking capability out to 48 miles, which serves as the Port's weather radar.

Future uses for the Port of Stockton's camera system will include integration into the Port Police Department. Currently, the cameras are useful during daylight hours only, or under adequate artificial lighting. In order for the Port Police to utilize this equipment in an effective manner, night vision lenses and/or thermal imaging will need to be incorporated into the system thereby providing the Port Police with the enhanced capability to complete their 24-hour-a-day mission.

## **REAL-TIME MEASUREMENT OF SHIP SQUAT**

by CAPT Thomas Richards, NOAA

Recent improvements in the accuracy and precision of measurements using the Global Positioning System (GPS) in the vertical dimension offer new opportunities to determine changes in vessel draft while a ship is underway. When a ship is underway the vessel changes

its draft from its static condition. Most present-day estimates of squat are computed values based upon theoretical conditions. Often one of the theoretical conditions is assumed to be deep water. As a vessel enters shallow water and as it encounters sea actions similar to those encountered on the San Francisco Bay entrance bar or the confines of narrow dredged channels, the amount that the ship's draft changes due to these environmental conditions is magnified and becomes less well understood. GPS technology offers an opportunity to effectively and efficiently measure these vertical movements of underway ships and predict conditions which could result in vessel groundings. Both NOAA and the Corps of Engineers have been conducting experiments in using GPS to monitor vertical movement of ships and improve the ability of GPS to make vertical measurements. They are exploring opportunities with various commercial shipping concerns and the San Francisco Bar Pilots to expand this research by conducting measurements aboard ships transiting the entrance bar and in restricted shallow channels of the bay.

## **DOCKING CHARTS**

by CAPT Thomas Richards, NOAA

One of the intriguing possibilities that has developed with the advent of electronic charts and precise GPS navigation has been the creation of very large-scale (1:1,000-scale) docking charts to aid pilots and ship's masters in maneuvering ships alongside the pier or dock. Frequently when docking today's very large ships, it is not possible for the person maneuvering the ship alongside to see from the bridge or bridge wing all points where the ship is about to touch. However, given a very accurately surveyed pier or dock, and an electronic chart system that is 1) linked precisely to differential GPS and 2) accurately tied the centerline and overall dimensions of the ship and its gyro; it is possible to construct a docking chart which can readily show the pilot and master just how the ship's form is coming alongside the dock or pier. NOAA is exploring opportunities with private producers of electronic chart systems and with port facility managers for further development of techniques and standards to facilitate the creation of docking charts for various ports within the San Francisco Bay region.

## **SUMMARY**

The list of initiatives is a lengthy one. But the list of benefits is also long. By cooperating the various players hope to further enhance the value and availability of these technologies to mariners. For instance, VTS will have a PORTS terminal and a

workstation running the current pattern model. VTS can then provide both real-time observations and “nowcasts” to pilots and other mariners. VTS is cooperating with the Bar Pilots on their evaluation of the Portable Pilot Units, even though no ADS tracking capability is planned during this evaluation. All Bay Area mariners are eager for the advent of electronic charts, with their attendant promise of more accurate navigation and easier updating. The Marine Exchange will share their improved ship arrival and departure information with VTS and the pilots.

As competition in the maritime industry intensifies worldwide, the San Francisco Bay Area is putting technology to work in order to compete efficiently and above all, safely.

## **CO-AUTHORS, CONTRIBUTORS, AND CONTACT INFORMATION**

LCDR Pete Marsh, USCG, is Executive Officer of Vessel Traffic Service San Francisco. Phone (415)556-2950. Email [xo/vtssfran@internet.uscg.mil](mailto:xo/vtssfran@internet.uscg.mil).

<http://www.dot.gov/dotinfo/uscg/dll/vtssf/vtshome.htrn>.

CAPT Thomas Richards, NOAA, is NOAA’s San Francisco Demonstration Project Manager. Phone (415)556-0858. Email [richards@.hazmat.noaa.gov](mailto:richards@.hazmat.noaa.gov). <http://www.ceob.nos.noaa.gov/portsframe.html>.

[www.ceob.nos.noaa.gov/portsframe.html](http://www.ceob.nos.noaa.gov/portsframe.html).

Captain Carl Bowler, San Francisco Bar Pilots, is the chairman of the American Pilot’s Association Navigation Technical Committee. Phone (415)362-5436. Email [plainurus@aol.com](mailto:plainurus@aol.com).

Dr. Ralph T. Cheng is project manager for the estuarine hydrodynamics project at the US Geological Survey in Menlo Park, CA. Phone. email [rtcheng@usgs.gov](mailto:rtcheng@usgs.gov). <http://sfbay7.wr.usgs.gov/~jonathan/CPA/CPA.html>.

David B. Enablit is Deputy Chief of NOAA’s Marine Charting Division. Phone (301)713-2724. Email [denabnit@rdc.noaa.gov](mailto:denabnit@rdc.noaa.gov). <http://www.nos.noaa.gov/ocs/>

USCG Navigation Center: <http://www.navcen.uscg.mil/navcen.htm>.

Mark Tollini is Manager of Port Operations for the Port of Stockton. Phone (209)946-0246. Email [portmail@stocktonport.com](mailto:portmail@stocktonport.com). <http://www.portofstockton.com>.

Roger L. Peters is a member of the Board of Directors of the Marine Exchange of the San Francisco Bay Region. Contact Terry Hunter, Executive Director of the Marine Exchange, at 415-441-6600. Email [74160.1341@compuserve.com](mailto:74160.1341@compuserve.com).



---

# American Bureau of Shipping SafeHull 96 Brings Significant Technology Developments

The introduction of the ABS SafeHull™ System in mid-1993 heralded a new era in marine safety. Since that time this innovative first-principles approach to the design and evaluation of ship structures has impressed the marine industry to an increasing extent, and by the close of 1995 it truly had gained acceptance worldwide. During the year the vanguard of SafeHull vessels were classed by ABS—first the shuttle tanker *HEIDRUN*, followed by the *VLCC ATLANTIC LIBERTY*, and then the bulk carrier *PACIFIC ACADIAN*. Many more such vessels will be classed in 1996 since by the end of 1995, 31 tankers and 24 bulk carriers were building or contracted to be built to ABS class employing SafeHull technology with a number of other newbuilding projects under review or discussion at that time.

## SAFEHULL TRAINING AND ASSISTANCE

As SafeHull's potential to improve structural safety and effectiveness became clearly evident to the industry there developed an overwhelming interest in learning more about its practical application. Consequently, to augment existing training programs, in mid-year ABS formed a SafeHull Support and Training Team, and late in the year a SafeHull Bridge Team.

The former, comprising twenty engineers from nine technical offices, was established to provide on-site training and assistance to SafeHull users worldwide. The team's primary function is to support shipyards with the consistent application of SafeHull, while also providing vital feedback to the ABS SafeHull Project Development Group regarding both the application of SafeHull criteria and software as well as ideas for refinement and further development. Another objective of the Support and Training Team is to train many of the 286 engineers from the thirteen ABS technical offices.

As the team became involved with shipyards it soon became apparent that some of them needed specialized assistance regarding the integration of the SafeHull System with their resident technology.

Therefore, the SafeHull Bridge Team was formed to provide a link between the shipyards and the support and Training Team to find unique solutions to sophisticated hardware and software issues related to the shipyard's engineering workstation computers. Another purpose of the Bridge Team is to help resolve technical differences such as those involving structural analysis and finite element modeling techniques. The team's members exhibit a variety of specialized technology and language skills.

Until the SafeHull Support and Training Team assumed the task in late 1995, SafeHull training for both ABS engineers and outside interests (primarily shipyard representatives) was conducted by the ABS Project Development Group, both at its Paramus, New Jersey center and at users' sites. In addition, seminars were held in various locations worldwide to explain to specific companies and industry groups the fundamentals and benefits of SafeHull.

## BULK CARRIER DEVELOPMENTS

In November, the Technical Committee of ABS approved SafeHull requirements as the mandatory strength criteria to be applied to the design and assessment of bulk carriers 150 meters and greater (as it similarly had for tankers a year earlier). These requirements, to be incorporated into the 1996 ABS Rules for Building and Classing Steel Vessels, will mark the first time any class society has required a finite element analysis as part of the design verification process for bulk carriers.

In extending SafeHull from tankers to bulk carriers, ABS was particularly mindful that due to structural redundancy this type of vessel does not possess the degree of durability and safety comparable to that of tankers. Consequently ABS engineers identified five structural areas and conditions warranting extensive consideration—transverse corrugated bulkheads in cargo holds, vertical hold frames, cross deck structures, forebody structures, and cargo overloadings. Their findings not only have been factored into the SafeHull System for bulk carriers, but also formed the basis for ABS recommendations for



improving bulk carrier structural safety – a matter of particular concern to the marine industry. These recommendations were the subject of very well received presentations and seminars held in a number of locations (which led to cooperative efforts with IACS and other industry groups, aimed at translating these findings into measures which will hopefully end the problem of bulk carrier casualties due to structural deficiencies.) Moreover, ABS published a brochure dedicated to this topic which required a second printing, due to worldwide demand.

Follow-on SafeHull bulk carrier studies focused on forebody structures, particularly of Capesize and Panamax category vessels. From these it was determined that green sea loads in way of the forward hatch covers under certain extreme conditions can be more excessive than previously thought. Consequently a new design pressure load within 0.25L of the forward perpendicular (i.e. generally the strengthening of the first and second hatches) has been factored into SafeHull for bulk carriers.

## CONTAINER CARRIER DEVELOPMENTS

In 1995 the SafeHull Project Team devoted most of their efforts to extending the SafeHull System to container carriers. The nature of their structure, different again from tankers and bulk carriers, posed unique and challenging problems. Nevertheless, the objectives were met and by the close of the year this ambitious undertaking for criteria development was essentially completed. The first part of 1996 will be given to verification and refinement, and it is expected that SafeHull for container carriers will be made available to the marine industry around mid-1996.

Of particular importance to container carrier structures is the design of hatch openings with regard to attendant loads, stresses, and distortions. SafeHull specifies calculations of hatch opening distortions based upon the magnitude of the ship's torsional moment and geometric properties.

Fatigue also is a critical concern in container ships. Through SafeHull studies, several structural details have been identified as particularly vulnerable to fatigue, and therefore have been factored into the SafeHull design and evaluation criteria. These are:

- Hatch corners of the main and second decks and hatch coaming at the top level
- Connection of the cross deck box beam to the longitudinal bulkheads
- Connection of the longitudinal deck girders to the

transverse bulkheads

- End connection for hatch side coamings including coamings stays and hatch end coaming
- Cutouts in the longitudinal bulkheads longitudinal deck girders, hatch side coamings and cross deck box beams

Transverse strength has become an increasingly important consideration with the trend toward larger-size container ships. Based on results of extensive finite element model analysis, SafeHull includes a transverse strength formulation for this type vessel. It also addresses fore-end strengthening, and container securing systems.

## SAFEHULL™ 96

As significant as the development of the ABS SafeHull™ System has, been to date, ABS views it as only the start of a new era. To build on SafeHull's initial success, ABS has labored productively to broaden its application and to make it more flexible and user-friendly. The results are a series of new products and services which will be presented collectively as "SafeHull 96"

SafeHull 96 includes SafeHull for container ships, the expansion of the SafeHull System to encompass the entire vessel, a new capability for using SafeHull in a Windows operating environment, and a new program including SafeHull for tankers and bulk carriers in one consolidated system. Other features of SafeHull 96 are:

- Windows Graphical User Interface
- A Relational Database Management System Interface
- CAD features for better model generation
- Translators to CAD systems
- Translators to various Finite Element Analysis solvers
- Context sensitive help screens

SafeHull 96 will provide shipyards and designers the opportunity to use the SafeHull System as a stand-alone and complete structural design tool, or to incorporate the applicable portions of the unique SafeHull criteria and software into their existing design procedures and in-house software. The goal of ABS has been to ensure that all users have the flexibility to make SafeHull a valuable addition to their design effort without imposing extensive learning and training requirements to the design process. SafeHull 96 will make major strides toward achieving this goal.

*Continued*

---

## THE BENEFITS OF SAFEHULL™

The SafeHull System is an Innovative dynamic-based method for the design and evaluation of hull structures developed by ABS. In essence, the virtue of SafeHull is that it can lead to safer, more durable ships through the identification of critical areas in the hull structure. For new designs, this means material can be placed where it is most needed for existing vessels it makes possible closer scrutiny of those critical areas during survey and more effective planning of maintenance schedules.

In applying SafeHull to new designs, the loads and the resulting stresses and displacements imposed on the hull structure can be quantified in an integrated and realistic manner. SafeHull provides an innovative flexible approach that explicitly considers the structures sensitivity to corrosion as well as the dominant failure modes – yielding, buckling and fatigue. The major benefits derived from applying SafeHull to new vessel designs are:

- Reduced risk of structural failure
- Safer, longer-lived tanker, bulk carrier and container ship structures
- Lower life-cycle maintenance and repair costs
- More effective use of steel for long-term benefit
- A more streamlined ABS review process
- A more rapid means for exploring innovative designs while maintaining safety and efficiency

Through ABS SafeHull Condition Assessment Services, vital information on existing vessels can be generated leading to the major advantages of:

- Effective determination of required steel replacements through dynamic based structural evaluation
- Additional protection against structural failures during tanker life thereby providing added protection to life, property and the environment
- Demonstration of due diligence
- Lower life-cycle maintenance and repair costs through more effectively planned surveys
- Potentially higher resale value through technological evaluation of hull integrity

The ABS SafeHull System for new tankers, bulk carriers, and container ships is a complete technical resource comprising two guides – one for dynamic-based design and evaluation of structures, and the other for fatigue assessment – as well as a comprehensive suite of software applications programs, technical support services, and related technical documentation and guidance.

## SAFENET

### *A life-cycle ship management and information network*

To assist shipowners with the increasingly complex task of managing their vessels, ABS has developed SAFENET, an easy to use life-cycle ship management and information network. The network will allow owners to access from their office, or even from a ship, all classification-related technical and survey information for both the machinery and hull structure on their ABS oceangoing vessels. SAFENET will include a machinery planned maintenance program, or be capable of linking to an existing program in use by the shipowner. Either alternative can be interactive with the ABS Survey Status. SAFENET will include a hull planned maintenance program based upon the ABS SafeHull structural analysis system. The network will also contain a broad range of general information on ABS, directories and reference listings. SAFENET will prove of great value to owners for something as basic as locating the nearest ABS surveyor or determining what documents are required for entering a specific port state; or as intricate as determining steel replacements, or developing an Enhanced Survey Plan.

The first module, to be offered from mid-1996, will include advanced on-line access to the ABS Survey Status database in addition to such general technical information as ABS design documentation, statutory requirements, and port state control check sheets as well as publications and directories.

The second module is more technical and ship specific allowing ABS and the owner to work together to continuously assess the integrity of both hull and machinery in order to develop a planned maintenance program for executing surveys, maintenance and repair. Storage, on-line, of ship drawings, gaugings and condition photographs will be part of the system to assist in the process of evaluation, which in the case of the hull, will encompass an extended SafeHull structural evaluation.

Future modules are planned to incorporate developing technologies including risk assessment analysis, image and multimedia technology for viewing and links to 'real-time' hull and machinery monitoring.



# SAFENET™

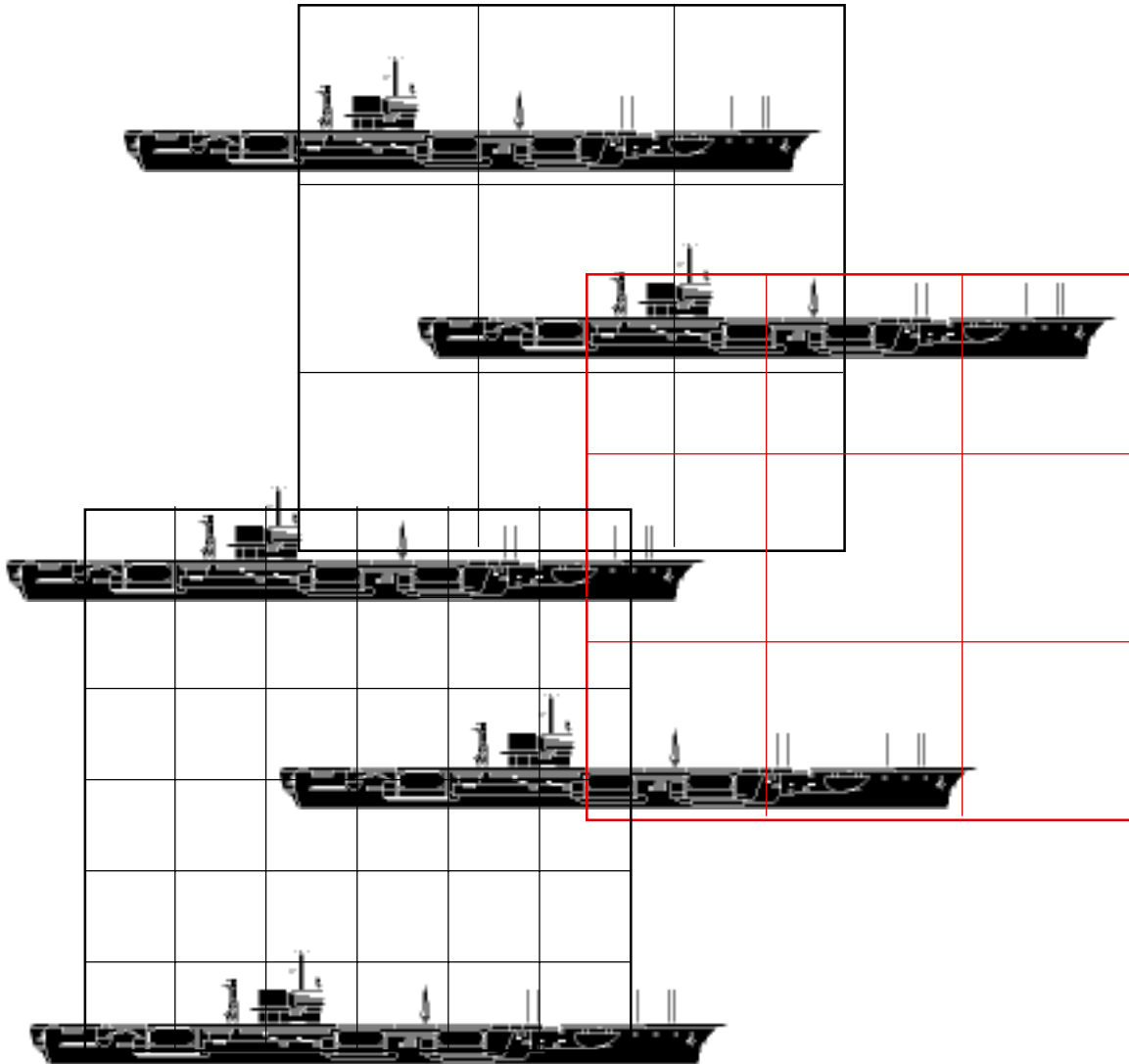

# Out of the Fog

by LT. Frank J. Elfring and Ms. Irene M. Gonin

It is ironic that ECDIS, which RADMEcker, former Chief of the Coast Guard's Office of Navigation Safety and Waterway Services, described as "the best navigation advance to come along since radar was invented" [1], finds itself adrift in a sea of double-talk and buzzwords. It's time to single-up on the double-talk and stow the buzz.

**ECDIS Key Point #1:** All ECDIS's are ECS's. All ECS's are NOT ECDIS's.

For many mariners, a laptop computer, with a picture of a chart, and icons moving across the screen in some semblance of harmony with the vessel's actual position, makes a great "ECS" but not an ECDIS. Likewise,

manufacturers, frustrated by their inability to obtain IMO compliant Electronic Navigational Charts (ENC), have incorporated workaround solutions in order to sell their product - a high-powered ECS. This has given rise to marketing terms such as "Near-ECDIS", "ECDIS-Like", "ECDIS Compliant (if there was the data)".

## WHAT IS AN ECDIS?

ECDIS presents accurate surface and subsurface chart data combined with real time position information, (i.e. DGPS, GPS, LORAN-C) on an Electronic Chart Display. Additionally, it incorporates information from other sensors (i.e. depth sounder, radar, gyrocompass, etc.) to provide a navigation Information System. Figure. 1 identifies the key elements of an ECDIS.

*Table 1 details the functions of an ECDIS, listed in the Performance Standard for ECDIS.*

ECDIS FUNCTIONS	Table
1. Contribute to safe navigation.	
2. Comply with up to date chart requirements of Chapter V paragraph 20 of the 1974 SOLAS convention.	
3. Display all chart information necessary for safe and efficient navigation.	
4. Facilitate simple and reliable updating of electronic navigational charts.	
5. Reduce navigational workload.	
6. Have the same reliability and availability of presentation as paper charts.	

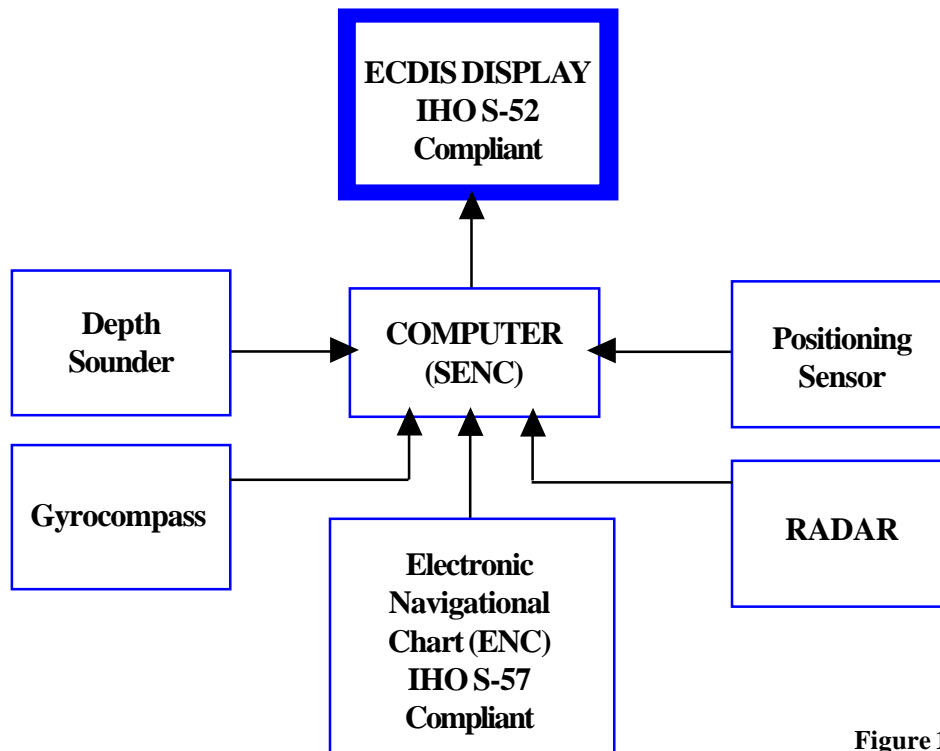

Figure 1

Table 2 describes many of the key features which are incorporated into an ECDIS.

ECDIS FEATURES	Table 2
1. Monitor own ship's position relative to its operating environment	
2. Accept official updates to ENC's	
3. Use IHO Colours and symbols to represent chart information.	
4. Alarm or provide an indication when own ship's position or course is in jeopardy of violating IMO recommended or user-defined boundaries.	
5. Allow the mariner to pre-plan voyage routing and test the overall route for validity and hazards.	
6. Keep a running log of the last 12 hours of the ship's voyage - similar to a flight recorder on an aircraft.	

ECDIS also has legal and regulatory recognition in the international maritime community. To achieve this recognition, an ECDIS must comply with a series of standards which defines its overall performance as a class of equipment (See function 2 table 1). The primary supporting standards, which are incorporated into the EPS by reference, include means for defining, managing, manipulating, and displaying accurate chart information. In order to ensure the accuracy, reliability and integrity of an ECDIS, the IMO, in cooperation with the IHO, required a specific data format for the creation of ENC's. Figure 2 illustrates this relationship.

### WHAT IS ECDIS'S PROBLEM?

Unfortunately, in the United States, the implementation of ECDIS technology collides head on with the current push for governmental program cutbacks and decreasing budgets. This collision leaves the United States unable to convert its present paper chart data into ENC's. The process to convert paper chart data to ENC's is not a small or inexpensive task. It requires people with the necessary skills and it requires MONEY.

**ECDIS Key Point #2:** ECDIS can work with existing data.

*Continued*

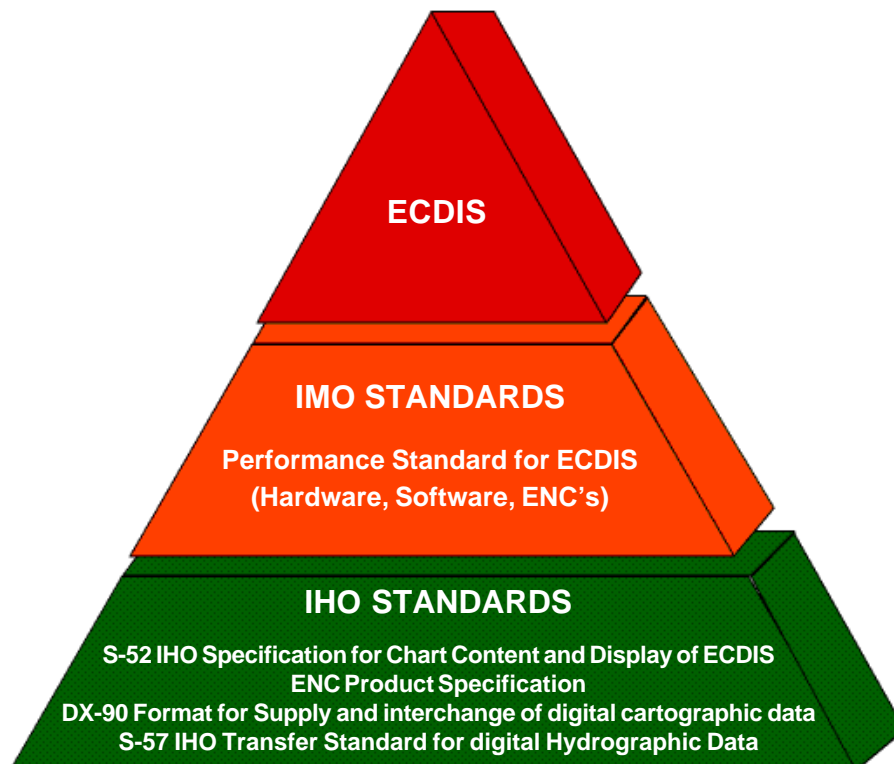
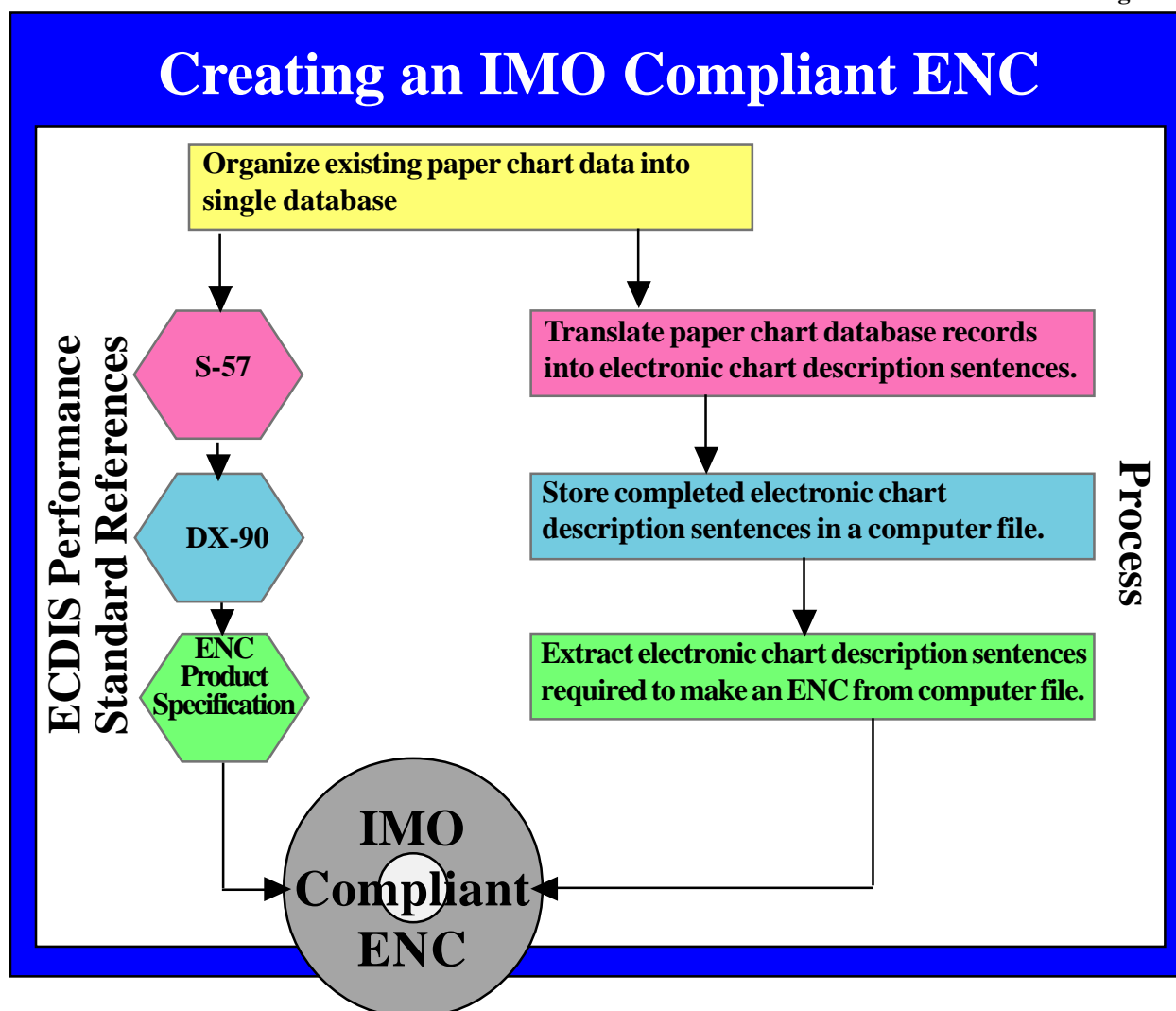

Figure 2

Figure 3



There is a misconception that the creation of ENC's requires the development of new chart information. Although it is desirable to obtain new hydrographic surveys to ensure the data is as up-to-date as the technology, it is not mandatory and it is not a requirement of the EPS (see Function 6, Table 1). If a tanker can leave Valdez with the latest available paper chart, correctly updated, it can leave Valdez with the same information, properly encoded, in an ECDIS.

### HOW ARE ENC'S DEVELOPED

**ECDIS] Key Point #3:** A Chart on a CD does not mean its an ENC.

In the United States, as well as elsewhere, there are many different types of electronic charts. However, ECDIS recognizes only one type of data –

the ENC. ENC is not a generic term, it refers to a type of navigational chart data that is developed through a specific process. Figure 3 identifies the EPS reference and illustrates the process to develop an ENC.

Unfortunately, without ENC's there is no ECDIS. This situation places the Coast Guard in an awkward position – both internally and externally. Internally the Coast Guard has committed to ECDIS technology for our new cutters. Externally, we cannot completely fulfill the Waterway Management vision set forward by RADM Ecker over three years ago: "Shore-based waterway managers and vessel traffic services will also be a part of the ECDIS system. An ECDIS display, can and will become a decision support system for Vessel Traffic Services and for the mariner of the future." [1]

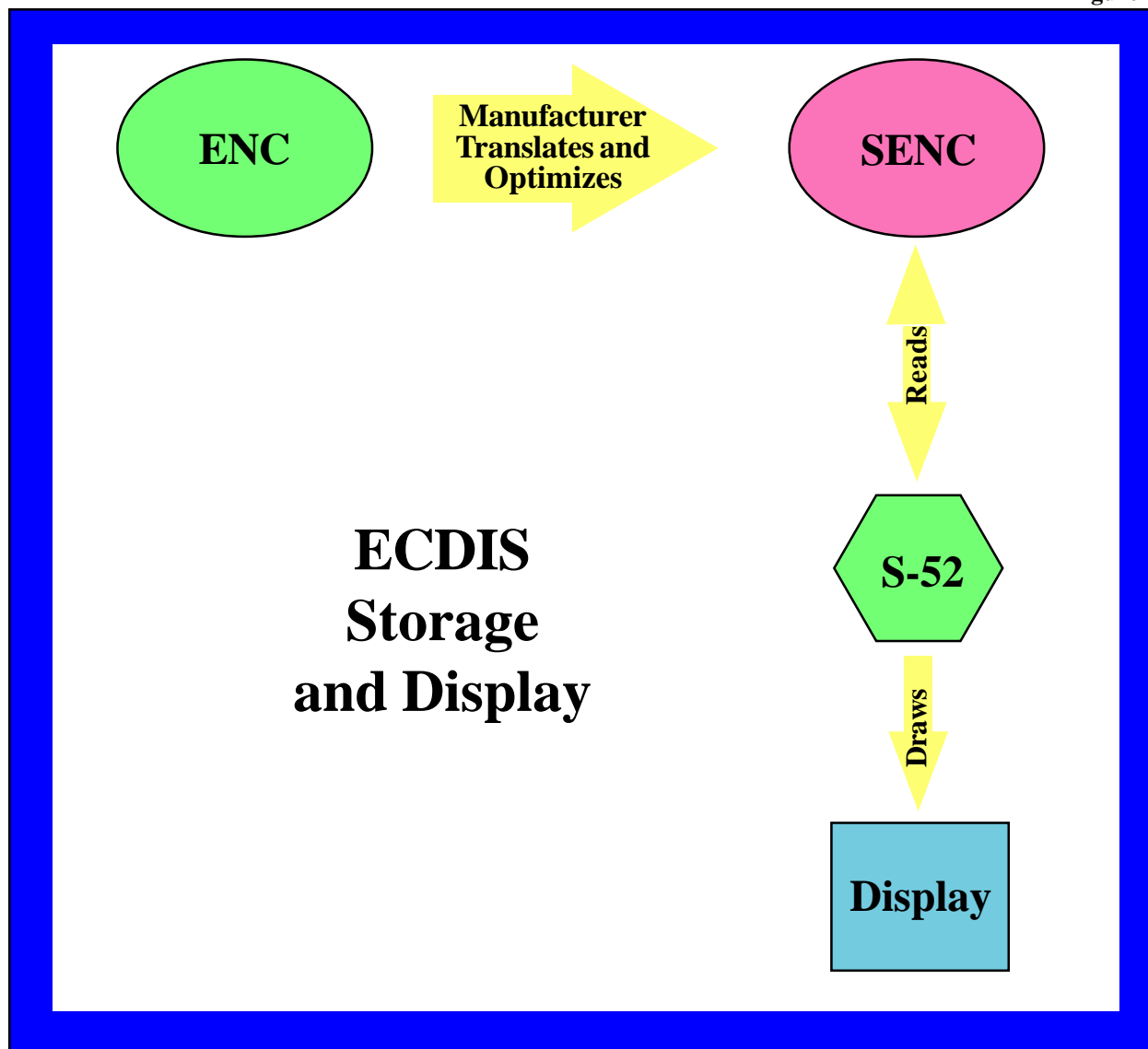

### WHAT DOES AN ECDIS DO WITH AN ENC?

ENC's are a convenient and verifiable means of transferring chart data between a Hydrographic Office and an ECDIS). It is not the most efficient means for displaying chart data on a display screen. For this reason, manufacturers may choose to perform another conversion or translation to provide a more efficient process for displaying the ENC.

Individual ECDIS manufactures are allowed to reformat, in a separate storage area, the information contained in the ENC for optimum system performance. The result of this reformatting is the System ENC (SENC). It is in the SENC that manufacturers can increase the desirability of their product through such measures as system speed, additional features, and desirable functions.

**ECDLS Key Point #4:** A SENC must be developed from the ENC.

It is important to remember the SENC is the property of the manufacturer. This translation process has allowed them to produce "ECDIS-Like" devices. They proceed from their privately developed data to the creation of a SENC. If the SENC is not developed from an ENC – it is not an ECDIS.

ECDIS is a class of equipment and not an individual system. For various reasons, primarily safety, it is necessary that the displayed chart information (i.e. the final output used by the mariners) be consistent across all systems, regardless of the source of the ENC or manufacturer.

This consistency is achieved through the use of IHO S-52- Specification for Chart Content and I Display Aspects of

*Continued*

## ACRONYMS & ABBREVIATIONS

**ACOE:** Army Corps of Engineers

**ARPA/MARITECH:** Department of Defense's Advanced Research Program Administration - Maritime Technology Program

**AtoN:** Aids To Navigation

**DGPS:** Differential Global Positioning System

**DX-90:** Format for supply and interchange of digital cartographic data (1990)

**ECS:** Electronic Chart System

**ECDIS:** Electronic Chart Display and Information System

**ENC:** Electronic Navigational Chart

**EPS:** IMO Performance Standard for ECDIS [Resolution A.817(19)] adopted on 23 November 1995

**GPS:** Global Positioning System

**IHO:** International Hydrographic Organization

**IMO:** International Maritime Organization

**NOAA:** National Oceanic and Atmospheric Administration

**RENCC:** Regional Electronic Navigational Chart Center

**RTCM:** Radio Technical Commission for Maritime Services

**S-52:** IHO Specification for Chart Content and Display of ECDIS

**S-57:** IHO Transfer Standard for Digital Hydrographic Data

**SENC:** System Electronic Navigational Chart

**SOLAS:** Safety of Life at Sea Convention

ECDIS. The S-52 is an artist in residence and found in all ECDIS. It provides the necessary drawing instructions for displaying the SENC across all ECDIS devices.

This IMO requirement ensures that a mariner will not have to learn a multitude of symbols and color specifications for the same chart objects (i.e. buoy, depth contour, etc.) depending on the ECDIS manufacturer. Figure 4 illustrates this relationship.

### WHAT ARE SOME POSSIBLE SOLUTIONS?

The solutions set forth here are the authors' opinions. That is not to say they are original thoughts. They are ideas we believe merit investigation. They are not workarounds but rather straight forward approaches to achieving a solution.

There are at least 3 possible solutions to overcome the lack of ENC's in the United States.

**1. RENCC:** Abandon any effort to develop ENC's in this country and provide our existing data to a RENCC. This has been implemented in Europe. Norway is the RENCC for many of its neighbors. In this hemisphere the logical choice would be Canada. The Canadian Hydrographic Service has a partnership with Nautical Data International and is working towards the development of IMO compliant ENC's. This method would also eliminate the burden imposed by our acquisition process.

**2. Partnering:** The development of ENC's would appear to be a perfect candidate for government/industry partnering. C-Map, with headquarters in Italy, believes that "with the endorsement and cooperation of the world hydrographic offices, we could easily complete 90% of an official ECDIS world database by the end of 1995. [statement made prior to 1995]," [3] In another article, C-Maps president, Dr. Fosco Bianchetti, details the development process and the quality assurance program associated with it. [4]

Transas Marine USA offers a solution to speed up the production of ENC data and to develop the necessary verification software for each hydrographic office. They also raise the need to resolve the copyright and royalties issues surrounding the ownership of chart data. They suggest the IHO manage royalty fees and oversee copyright agreements. [5]

The key benefit derived from pursuing a course in partnering would be the rapid development of ENC's. Tradeoff's would include the right of the commercial partner to profit from ENC sales, while the sanctioning



hydrographic office would retain the liability. A second consideration would be how such a system could function in our federal acquisition environment.

**3. Education:** This solution requires focusing the energies of all stakeholders in raising a higher congressional awareness of the importance of ECDIS. This would include manufacturers, ship owners, pilot associations, port authorities, federal and local environmental organizations, underwriters, NOAA, and the Coast Guard. Since all issues involving ECDIS affect marine navigation, the US Coast Guard should rightfully take the lead on this issue.

## SUMMARY

In the early 18th century the British Parliament offered a 20,000 pound reward to whomever could devise a reliable method of calculating longitude while at sea. The most critical factor in this undertaking was precise time. Sir Kenelm Digby, in his chase for the reward, proposed the use of a magical long-distance healing powder. He proposed that a wounded dog should be taken on every sea voyage, with a piece of its bandage left in London. At noon every day in London the bandage would be sprinkled with the magic powder stinging the dogs wound and making him yelp. By calculating the time difference between shipboard noon and when the dog yelped, the navigator could calculate his current longitude. [6] The invention of the chronometer proved to be a more humane and far more accurate method of time keeping.

Likewise, ECDIS has the potential of replacing the “yelping dog” of paper charts and workaround solutions with a far more precise and timely navigation tool. ECDIS is the key to the implementation of many of the emerging bridge technologies - Integrated Bridge Systems, Dynamic Positioning Systems, Integrated Navigation Systems. ECDIS provides the mariner with the necessary information to effectively make use of

these technologies. Without ECDIS’s real time navigation capabilities and its intentional recognition as a class of equipment, the ability to use it for the benefit of safe navigation is severely hampered.

## REFERENCES

- 1) Ecker, W. J. US. Electronic Chart -Display & Information System Test & Evaluation Program Review, US ECDIS Test and Evaluation Program Update. US Merchant Marine Academy, Kings Point, NY, March 2, 1993.
- 2) International Maritime Organization. Performance Standards for Electronic Chart Display and Information Systems (ECDIS). A 19/Res 817, 23 November 1995.
- 3) The Start is the chart... Marine Log. Pp. 34-39. October 1995.
- 4) Bianchetti, F. The impact of the New IMO ECDIS Standard on the ECDIS Manufacturing Industry. Marine Electronics. Pp, 16-18. May-June 1995.
- 5) Transas Marine USA. Some Considerations Concerning ENC, ECDIS, AND ECS. 1994 COE Meeting, Monaco, 1994.
- 6) Maddox, B. All in Good Time. The Washington Post Book World. Final Edition, Pg.2, November 26, 1995. [Book Review of Longitude by Dava Sobel]

## ABOUT THE AUTHORS

LT. Elfring is the program engineer for Vessel Traffic Services (G-MOV-2) at Coast Guard Headquarters.

Ms. Gonin is the Program Manager for the Integrated Navigation Systems Project at USCG R&D Center, Groton, CT.



---

# Sharing Coast Guard Information Via the Port State Information Exchange System (PSIX)

by LT Bill Butler

“...we must strive to establish a better means for States to exchange and analyze vessel casualty and violation information. I propose an International Information Network and Database, accessible by all administrations, classification societies, insurance underwriters, and prospective charterers. I envision a system which would allow these groups to access the system and acquire real-time information concerning a particular vessel’s safety history...”

**--Admiral J. William Kime, Commandant.**

PSIX grew out of Admiral Kime’s comments to the International Maritime Organization (IMO) on 25 June 1993. In recent years, the maritime industry has shown an increased desire for information about Coast Guard boarding histories. To satisfy this demand, PSIX was created to provide the maritime industry at large, and port and flag states with electronic access to a powerful tool for identifying substandard vessels entering ports around the globe. Essentially, we would share our vessel information collected by our field units with the world. In October of that year, we returned to the IMO with our first public demonstration of PSIX. Today, the maritime industry and other governments are using this technology for “key decisions” regarding vessel safety and port state control issues. The results of these decisions could lead to a safer marine environment.

It is our view that there is a series of “safety nets” intended to keep a ship, its passengers, crew, and cargo out of harm’s way. The primary safety net is the safety management structure provided by the vessel owner and operating company. The second “net” is the classification society working with the vessel underwriters. The third “net” is the flag state administration, and the final “net” is the port state. In theory, if the first three safety nets are functioning properly, the port state should not find many deficient vessels. If a large number of substandard vessels are slipping through the first three nets, there must be problems. One of the keys to mending these is to provide information that identifies the weak links. PSIX

provides a vehicle for that information.

PSIX also lets the Coast Guard satisfy the increasing number of inquiries originating from “new” customers requesting vessel information. With PSIX, the public is free to obtain commercial vessel information extracted from the Coast Guard’s main database, the Marine Safety Information System (MSIS). Additionally, we are finding that customers who generally need vessel information on a recurring basis, like chartering agents, are finding PSIX a very useful tool in their decision making process. This information could be a deciding factor in whether or not a specific vessel will be chartered.

Meeting Admiral Kime’s primary objective, PSIX creates a “sharing” of information with other states. The Coast Guard has taken this initial step, but we are hoping other maritime states replicate our system. Furthermore, we are hoping the PSIX will become part of the much larger International Ship Information Database (ISID) that is being considered by IMO. With ISID, information on all commercial vessels would be accessible to the maritime public. As of this date, PSIX contains only information on US vessels and international vessels making US ports-of-call. By sharing our PSIX system with the maritime community, our customers will be part of the campaign for maritime safety.

PSIX provides very specific vessel activity information, such as a historical case number and specific vessel deficiencies. Vessel data can easily be downloaded to our customers’ computer, providing them with the ability to analyze Coast Guard safety boarding and deficiencies since 1989. When our customers contact us about a specific boarding or interpretation of a deficiency, we can quickly reference the case number to expedite our response.

Since Admiral Kime’s speech to the IMO, PSIX has received many improvements. Several of these improvements have come directly from industry feedback. One of the first improvements was to facilitate more concurrent users. In March 1995, an

enhanced version of PSIX, Version 2.0 was released. This version introduced a "menu" driven application which includes vessels search capability based upon anyone of the following:

- (1) Vessel Identification Number (VIN);
- (2) Vessel call sign; and,
- (3) Vessel name or partial name.

Furthermore, we added more modems with higher transfer rates, thereby reducing on-line time. We are currently working on these improvements:

- (1) adding higher speed modems;
- (2) providing more vessel/boarding history information; and,
- (3) installing an 800 number for inquiries.

Eventually, we hope to have a "homepage" on the World Wide Web that will enable users to provide queries.

## FREQUENTLY ASKED QUESTIONS (FAQS)

### *The costs...*

The cost to the customer is the cost of the long distance phone call [the (202) area code]. The cost to the Coast Guard is nearly non-existent because PSIX is residing on a platform that has ample room to share its CPU processing power. The real costs savings are immeasurable. By giving the public a tool to access information regarding a vessel's safety record and listing of deficiencies, we reinforce our safety nets.

### *User Access..*

Essentially, anyone with a computer and modem can access PSIX. PSIX can be accessed with Apple, Windows 3.x, Windows 95, ProComm, or Kermit. Connections to PSIX may be established using the following communication settings:

Baud Rate: 1200bps to 14,400bps  
Stop Bits 1  
Data Bits 8  
Flow Control: Xon/Xoff  
Modem Number: (202)267-4333

Most of today's software will automatically default with the correct settings.

## PSIX USAGE...

Our customers include everyone involved in the maritime industry: owners, operators, shipping agents, underwriters, marine surveyors, classification societies, legal representatives, port authorities, etc. We have even had inquiries from government agents from other countries. When a new user logs into PSIX, he or she is given the option to declare his or her profession. This option allows us to determine our customer base and it also identifies which customer "types" are our most active users.

PSIX receives approximately 500 users per month and these users access between 1000 and 1200 vessel histories. Approximately 95% of our customer calls come from within the United States and approximately 25% of vessel downloads are reports on foreign flag vessels. We are hoping the number of our foreign customers will increase, but at the same time, we understand that many of our foreign users are represented by shipping agents here in the U.S.

## CUSTOMER INQUIRIES...

For more information about the PSIX System or obtain technical assistance, please contact:

Commandant (G-MRI-3)  
U.S. Coast Guard Headquarters  
2100 2nd Street SW  
Washington, DC 20593-0001  
Phone: (202)267-0452  
Fax: (202)267-4402

Or, contact the PSIX Project Officer:  
LT William R. Butler  
Phone: (202)267-0390  
E-mail: wbutle.comdt.uscg.mil



# Controlling Microorganisms in Diesel Fuel ... A New Solution to an Old Problem

By Mr. F. X. McGeechan

The Marine industry has long been plagued with the problem of “bugs”, the microorganisms that live and grow in fuel, fuel tanks, cargo and ballast tanks and lube oil systems. This contamination problem has grown to such proportions that it is considered almost epidemic. New technology is now available for permanently eliminating microbial contamination problems in a clean, safe and environmentally friendly manner.

The basis for growth of microbes is water. All fuel oil contains some water and, therefore, microbes in varying quantities. These “bugs” flourish at the oil/water interface, using the oil as their food source. Temperatures normally experienced in engine room environments (60 to 95 degrees F) provide ideal breeding conditions. Most affected are light oils, e.g., MDO (marine diesel oil), GO (gas oil), some lubricants, and generally any oil with a boiling point below 700 degrees F. Although less common, heavier fuel grades are sometimes affected but fuel heating often resolves the problem.

“Bugs” present many problems to ships’ engineers. These include filter plugging, clogged fuel lines and high rates of corrosion in fuel tanks, ballast water tanks and bilges. It has become so prolific that the IMarE has appointed a special subcommittee comprised of authorities including IMO and shipping industry representatives to study the problem and recommend solutions. Some aerobic microorganisms, commonly referred to as “algae”, if left unchecked will grow into colonies, forming mats or long strings of seaweed like structures. Other bugs, anaerobic ones, known as SRBs (sulfate reducing bacteria) are referred to as “metal-eating bacteria”. They combine with moisture to produce sulfuric acid that is responsible for corrosion in fuel components, injectors, and tanks. Quoting from Marine Engineers Review, January 1996, “Heavily infected fuel will, within just a few hours, result in filter plugging, fuel starvation, injector fouling and purifier malfunction. Non-uniform fuel flow and variations in combustion may accelerate piston ring and liner wear rates and affect camshaft torque.”

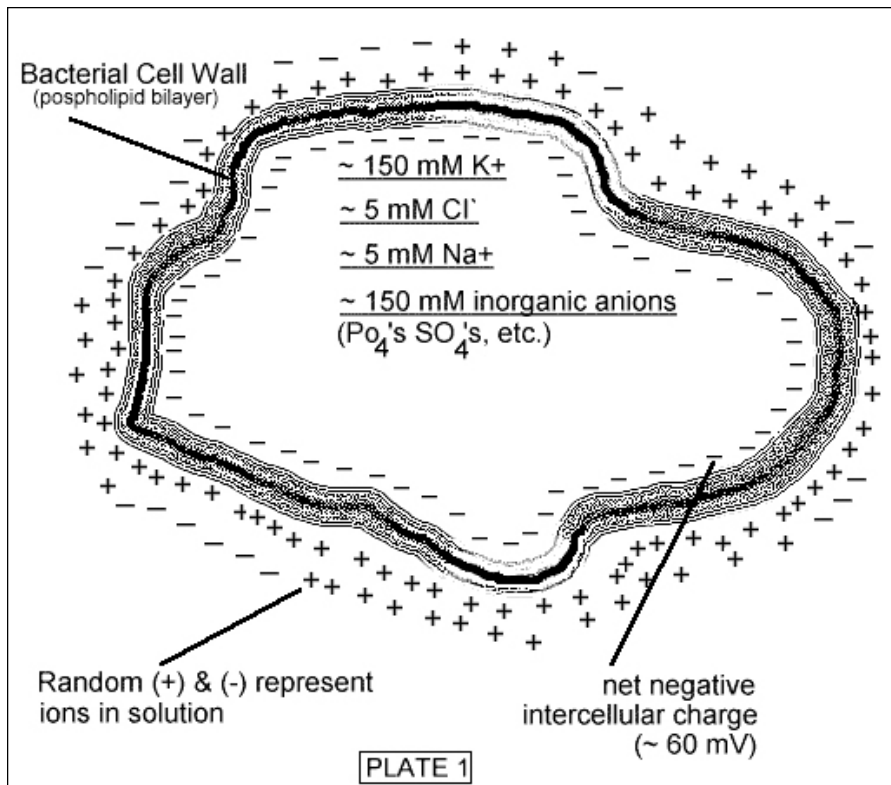

## ADVANCED TECHNOLOGY

Although relatively unknown in the US, within the last ten years, a new technology using magnetic flux fields to combat the “bugs” and their associated problems has been developed in New Zealand. The theory that magnetic flux fields inhibit microorganism growth and survival has long been noticed. There is an old story about a Scottish marine engineer who observed that the fuel oil supply line and filters to his port generator had fewer clogging problems than to his starboard generator. He determined that the difference between the two fuel supply systems was that the port fuel line passed through a magnetic flux field. The engineer

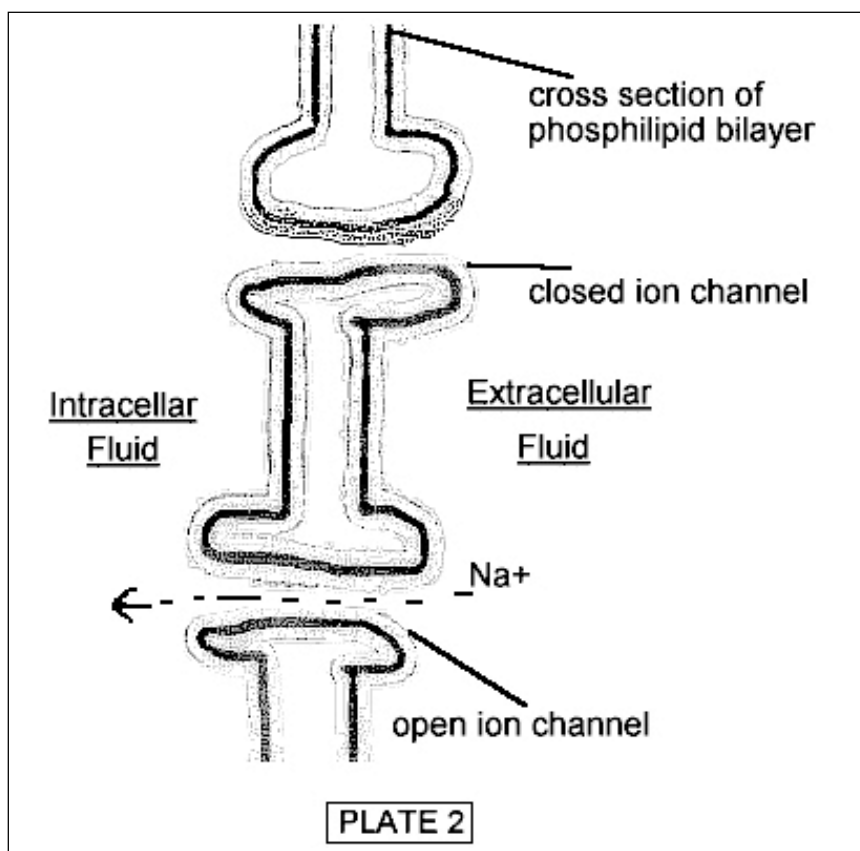

maintenance of the impermeable phospholipid membrane is essential for cell life. The bacteria cell membrane contains protein channels that transport different ions across the membrane to control both electrical and chemical potential that exists across it (Plate No. 2). When microorganisms are subjected to a strong magnetic flux field, the ability of the protein channels to maintain the electrical and chemical potential across the cell's membrane is greatly affected. In brief, the membrane is drastically torn apart and the microorganism is destroyed.

The question arises—What remains after the microorganism is ripped apart? Since we are dealing with microbe sized organisms, the resulting debris after destruction are sub-micron in size. These debris remain suspended in solution and are small enough to pass through primary and secondary filters, delivery pumps, diesel pressure

pumps and injector tips. They are then burned with the fuel, leaving no hazardous material with which to contend.

## WHAT ABOUT BIOCIDES?

A common method for killing “bugs” is to dose fuel with biocides. However, typical biocides are so highly concentrated that even a small spill can be potentially devastating. These toxic chemicals which kill the fuel “bugs” are also poisonous to all other animal and plant life. Further, tank bottoms containing biocides become more dangerous to handle and fall within regulated controls for hazardous material disposal. Recently, a study that focused on the effects of biocides in fuel combustion revealed an increase of NOx between 0.002-0.004% above the normal NOx emissions. Although this appears to be negligible, it cannot be ignored as the EPA regulates the sale of additives that contribute to air pollution. As a result, Biocides are beginning to cause concern as they are dangerous to handle and damaging to the environment. Some countries may prohibit their future use.

Biocide dosing of fuel can cause other problems. “Fallout” of dead cells to the tank bottoms forms sludge that could still find its way through the fuel system, clogging fuel lines and filters, potentially leading to

*Continued*

concluded that somehow this controlled the material that caused the fuel line and filter clogging.

Some ten years ago, Lindsay Forrest, a New Zealand marine engineer, after observing a similar phenomenon, put together a team to prove this theory and then developed a practical device to control microorganisms in marine diesel fuel. After many years of scientific research and development to produce the proper “flux field environment”, they introduced the De-Bug™ Model L-1000 Fuel Decontamination Unit. The success of this unit is based on a specific flow rate through a patented stack of three ceramic-coated permanent magnets (Tri-mag™) which achieves a microorganism kill rate efficiency of nearly 100% (97.6%) in one pass.

## WHY MICROORGANISMS HATE MAGNETS

Microorganisms are single-celled organisms surrounded by a phospholipid membrane. The purpose of the membrane is two-fold. First, it physically contains the cell's organelles and the other cellular machinery (proteins) needed for survival. Second, it maintains a separation between the intracellular and extracellular salt solutions in which the cell exists (Plate No. 1). This separation of the ions across the bacterial cell wall and the

performance problems and engine damage. Further, over time, biocides do not assure control of microbes, as typically the microbes build a resistance to the product through the evolution process.

## DE-BUG™'S IN USE

De-Bug™ units have been used successfully in a wide range of sizes and in various applications. De-Bug™ users include: military forces of several nations; marine interests; other transportation sectors; police and fire services; and commercial/industrial sector clients.

The largest unit in use to date is a Model L-50,000 (with a design flow rate of 13,225 gallons per hour) installed, with ABS approval, on the 267 meter M/V Cossack Pioneer.

## CONCLUSION

Regardless of the problem; complete fuel line plugging, corroded injectors, reduced filter life, or just minor symptoms, microbial contamination exists and

cannot be ignored. The long term effects on vessel operation and maintenance costs are critical. Aside from the fact that Biocides have some health and environmental risks, they also require continual application with the associated ongoing costs, and have questionable long term effectiveness. De-Bug™ units are an environmentally safe solution for killing and protecting against the "bugs". As a permanent installation, with no moving parts and little maintenance (occasional check of the bowl for water), De-Bug™ units pay for themselves many times over. Further, the liability of crew members handling toxic biocide materials is eliminated.

Mr. F. X. McGeechan, a USMMA graduate, is the Technical Director of Environmental Solutions International, Inc., telephone (703) 620-2204 or (800) 411-3284. Mr. McGeechan also consults as the Chief Engineer, Fuels and Lubricants, Trans-Tec Services Inc. He is retired from Mobil's international Aviation and Marine Corporation as the Marine Chief Engineer for the Western Hemisphere.



# Ship Structural Integrity Information System (SSIIS)

Prof. Robert Bea, University of California Berkely  
and LCDR Rob Holzman, USCG HQ, Naval Architecture Standards

## INTRODUCTION

The objective of a Marine Structural Integrity Program (MSIP) is to develop a basis for practical programs to develop and maintain desirable and acceptable quality in ship structural systems throughout their life cycle. Information and communications are key elements in development of ship safety and quality management systems. A MSIP Information System addresses the life cycle aspects of a ship including design, construction, maintenance, and operations. The Information System provides timely and meaningful information to help achieve desirable quality in ship structures for ship owners and operators, ship yards, classification societies, insurance groups, and regulatory agencies. It is intended to foster development of cooperative and intensely

communicative associations among the major sectors with a focus on safety and durability issues (Fig 1). This would include the results of inspections, hull response monitoring, maintenance programs, repairs, modifications, replacements and assessments of performance.

The Information System takes full advantage of modern computation, communications, and information technology. Substantial improvements in ship design, construction, maintenance, and operation efficiencies are the primary objective of the Information System. Safer ships and higher reliability organizations to design, construct, maintain, and operate ships are a natural by-product of such a development. The Coast Guard R&D Center and the Interagency Ship Structure Committee has sponsored

*Continued*

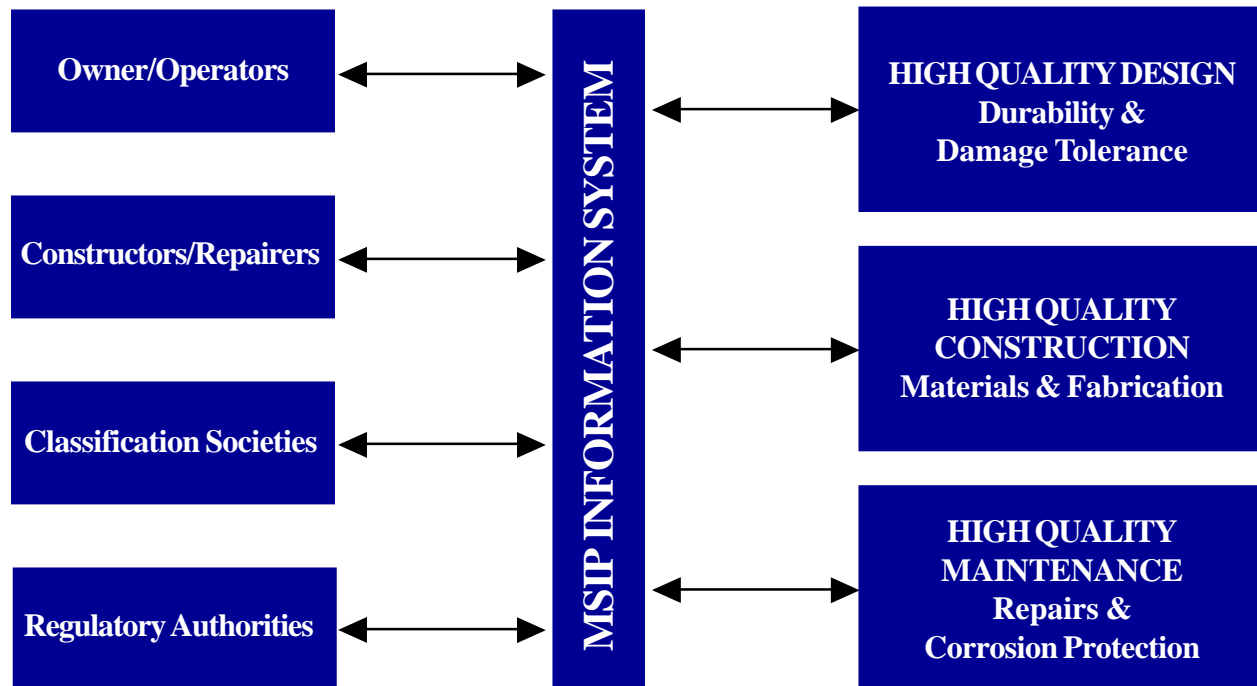
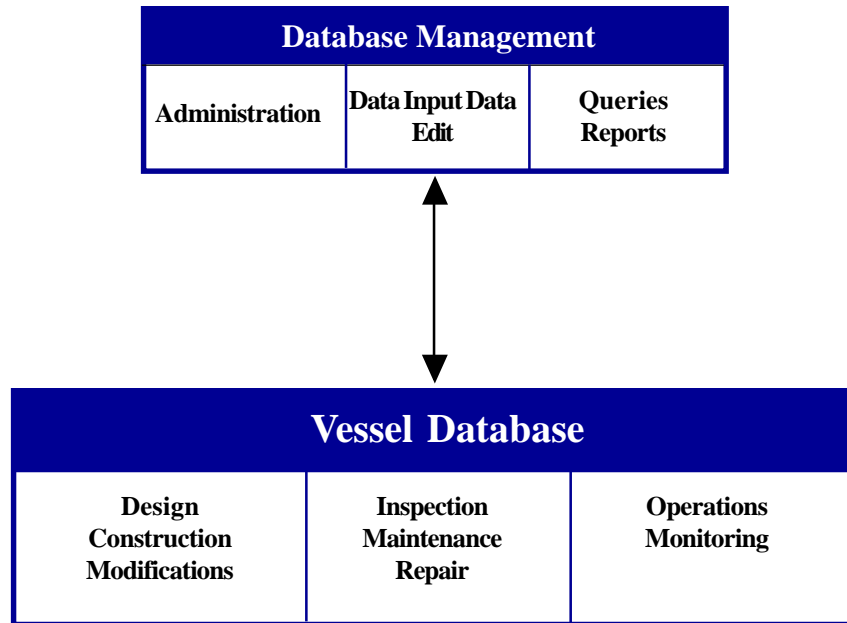

Figure 1 Ship management communication and information system.

Figure 2 SSIIS conceptual overview.



U.C. Berkeley through the National Maritime Enhancement Institute to develop a MSIP Information System called the Ship Structural Integrity Information System (SSIIS).

The overall, modular structure of the SSIIS database is based on an evaluation of existing database systems and of different vessel analysis procedures. The definition of the overall data structure is intended to serve as a guideline for a future commercial development of the SSIIS. Fig 2 shows the overall structure of the SSIIS.

The core of the system is the Vessel Database which contains eight different information modules. The different modules can be grouped into the three areas; vessel configuration, vessel maintenance and vessel operations. In order to manipulate the information contained in the Vessel Database, a Database Management System is needed. This system has the three main purposes; administration, data manipulation, and data analysis. The modular concept makes it easier to comprehend the large amount of information that has to be included in the SSIIS database structure.

## STRUCTURAL INSPECTIONS MAINTENANCE, REPAIR

The Structural Inspection, Maintenance, and Repair (IMR) process includes all potential structural quality failures such as, corrosion, cracking and member/detail overstressing. It includes ongoing maintenance such as tank coating and anode replacement and also the need of crack repairs.

SSIIS has been developed to address the IMR process. The structural IMR information process flow is detailed in Fig 4. Figure 4 highlights the activities associated with the IMR cycle, both as functions performed externally to the information system and as activities performed by the information system.

Inspection planning forms an integral component to improving the quality of ship inspections. Planning for inspection includes the selection of critical ship details. Those details that have been shown, either by analysis or experience to be those with the highest probability of failure. The purpose of planning an inspection is to ensure that the critical areas are included into the inspection plan and to also estimate resources and time required for the inspection. It is envisaged that in a full implementation of the SSIIS development an inspection plan is developed tank by tank, frame by frame and then detail by detail. This generates a large amount of paperwork for the inspector to handle and hence inspection recording devices should be incorporated to coordinate this information.

One of the benefits of SSIIS is the ability to customize the presentation of information for the user. The SSIIS allows the user to generate an inspection plan based on different inspection techniques and conditions. The SSIIS allows the inspector to work through the inspection prior to entering the tank and formulate the most effective

*Continued*



# Vessel Database

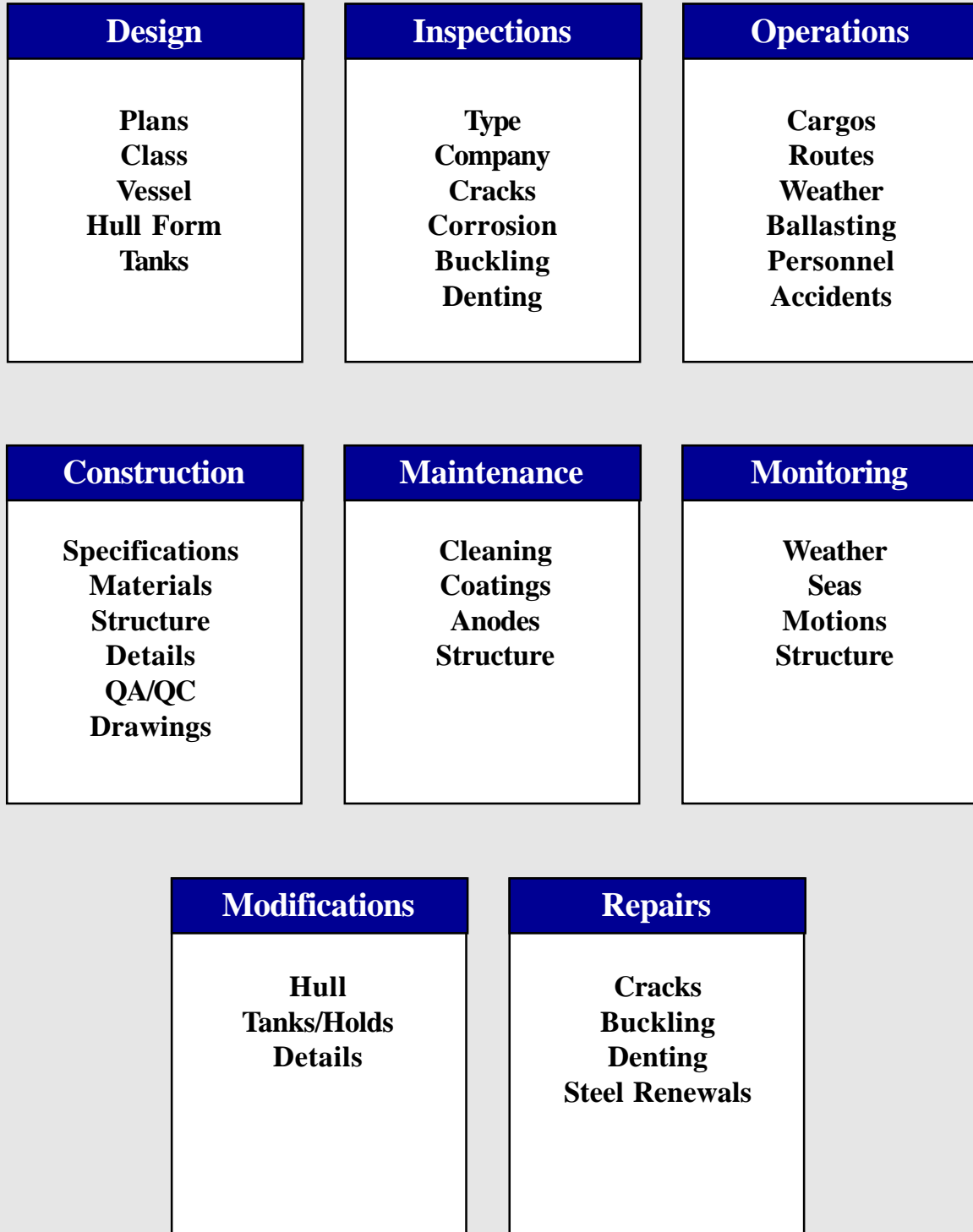
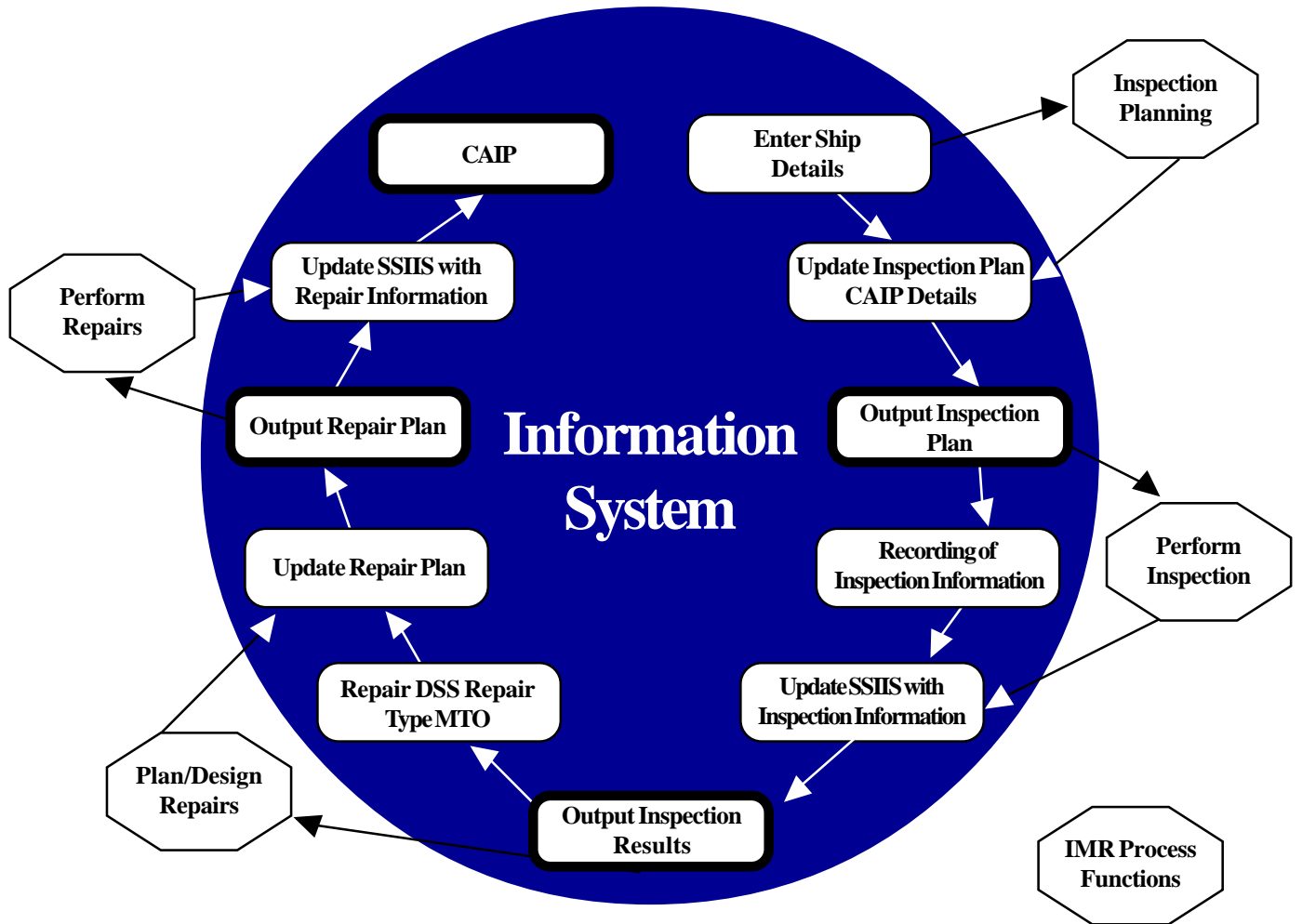

Figure 3 SSIS vessel database structure

Figure 4 Structural IMR information process flow



and efficient technique of examining the vessel for defects. An inspection plan is advantageous since it insures that critical regions receive attention. The inspection plan can be formulated to interface with technology used during the inspection.

Once defects are found, the IMR, cycle moves to planning and designing appropriate repairs. The repair chosen will depend on a number of factors such as, remaining vessel operational life and defect location. This decision is largely taken on a cost/benefit analysis incorporating short and long term costs. The choice of repair technique, from simple re-welding to the replacement of steel, has significant impact on the repair costs. Thus, the operator must weigh off the short-term costs against the long-term drawbacks of potential further work. Repairs to the ship structure must be carried out according to classification society and regulatory requirements. Repair information must be entered against

inspection failures to document the effectiveness of the repair.

### SSIIS PROTOTYPE

The SSIIS prototype is a Microsoft (MS) Access v2.0 database that focuses on the Structural Inspection Maintenance and Repair (IMR) process as shown in Fig 4. However, the Structural IMR process requires information from other processes. For example the: Structural IMR process is reliant upon the vessel description created in the Analysis/Design process. Failures and other defects must have a recorded position to gain maximum benefit for the integration of information into a process-orientated information systems. The prototype is intended to demonstrate the application of an information system, the data requirements maintained in the database have been kept to a minimum. Comprehensive data structures have not

---

been developed and the focus to the prototype has been on the information associated with the structural IMR process. At present, the outline for three reports has been programmed into the prototype; vessel configuration, inspection information, and a Critical Area Inspection Plan (CAIP) report. The data structures have been developed to demonstrate a working version of a structural IMR system. It is anticipated that future developments will detail the system further through feedback and comment from industry groups.

LCDR Robert Holzman is a Naval Architect in the office of Design and Engineering Standards

Prof. Robert Bea is a professor at the University of California, Berkeley.



---

# Realizing the Promise of Automation Through Better Design and Training\*

Dr. Anita M. Rothblum

Adding automated equipment to ships will increase efficiency, safety, and maybe even make the crew's life a little easier – right? Not necessarily! When the equipment is designed appropriately and used by trained mariners, automation certainly can be helpful in improving operational efficiency and safety. But if the equipment is poorly designed, or if it is used by under-trained (or untrained) personnel, it can be a contributing cause to accidents.

Take, for example, the sinking of the barge *DUVAL 2* by the containership *JURAJ DALMATINAC*. The accident occurred in the Houston Ship Channel under conditions of dense fog. Because of the fog, the towboat *FREMONT* had pushed its barge, *DUVAL 2*, over to the side of the channel. There were two pilots aboard the *JURAJ DALMATINAC*, but neither pilot knew how to use the ship's Automated Radar Plotting Aid (ARPA). While there were several different events which contributed to this accident, the National Transportation Safety Board concluded that had the ARPA been used, the pilots would have seen that the *DUVAL 2* was stationary (rather than under power, as they had assumed), and could have given it sufficient berth to avoid the collision.

Casualties caused by improper use or lack of use of automated equipment are hardly rare events. In one study of 100 marine casualties which occurred between 1982 and 1985, inadequate knowledge about equipment was found to be a contributing cause in 35% of the casualties. It would appear that many mariners lack sufficient training to use equipment properly under some conditions. But lack of knowledge is not the only problem. Poor equipment design was found to contribute to 33% of these casualties. When equipment is poorly designed, it can make errors inevitable.

The U. S. Coast Guard Research and Development Center is studying how automated equipment aboard ships impacts the job of the mariner and the skills the mariner must possess in order to use automated equipment effectively. To date, our studies have focused on the use of ARPA and ECDIS (electronic charts), but the general findings are applicable to any automated system.

## HOW DOES AUTOMATION IMPACT THE MARINER?

In order to correct the problems of inadequate training and poor equipment design, we must understand the impact of automation on the mariner. When automation is introduced, the mariner's tasks change: certain manual tasks may no longer be required (such as computing the closest point of approach using ARPA), and there are new tasks specific to the operation of the automated equipment (like calibrating, using menus, activating features). In some cases, tasks which were formerly performed by two or more mariners are now combined into the responsibility of a single crew member. For example, some integrated bridge systems (IBS) incorporate steering controls, GMDSS (Global Maritime Distress and Safety System), and a remote engine room alarm panel into the navigation console. Thus, the navigation officer is now responsible for tasks formerly performed by the helmsman, radio officer, and a member of the engineering watch. Due to changes in the way automated tasks are performed, the introduction of an automated system will require that mariners receive additional training. Training alone cannot guarantee that mariners will be able to use automation successfully if the equipment has not been designed with an appreciation for the mariner's tasks.

## HOW EQUIPMENT DESIGN CAN PROMOTE ERRORS

Poor equipment design can induce the mariner to make mistakes. When equipment is designed without considering the needs of the human operator (i.e., poor human factors design), the result can be a design which makes errors inevitable. All too often, equipment designers are not sufficiently familiar with maritime operations to understand how maritime tasks are performed, including the types of information required by the mariner in order to make timely operational decisions. Designers sometimes automate tasks which are "easy" to automate, without proper regard for how that set of tasks fits in with the other tasks performed

by the mariner. Important controls and information are sometimes buried under layers of menus, and data may be presented in an obscure fashion. Instead of enhancing the mariner's capabilities, designs like these actually make the mariner's job harder and can be detrimental to safe, efficient operation by increasing the likelihood that the mariner will make errors. By studying the types of errors commonly made by mariners using automated equipment, and by understanding the ramifications of these errors (i.e., are they just nuisance errors or can they cause an accident?), we gain important information that can be used to improve equipment design and training.

Automation tends to cause two different types of human performance errors: "slips" and "mistakes". Slips are the result of a momentary lapse of attention or memory. For example, forgetting to change the ARPA display mode from true vectors to relative vectors for evaluating collision potential would be classified as a slip. The resulting decisions about collision avoidance could be correctly carried out, but because those decisions were based on erroneous information (due to the wrong display mode), a collision might still occur.

One characteristic of ECDIS design which increases the probability of slips is the screen size. The ECDIS screen is much smaller than a traditional paper chart. In order to view a chart on the ECDIS, the mariner must display a relatively small section of the chart and use the "pan" and "zoom" features of the ECDIS to view other sections of the chart. This requirement to move through a series of smaller views in order to see the entire chart is called the "keyhole effect" (because it is like trying to view a paper chart through a keyhole). Since the mariner cannot easily refer to different sections of the entire chart on ECDIS (as one could by simply glancing at different sections of a paper chart), more of the chart information must be assembled in the mariner's memory, in order to have a mental image of the entire chart. The keyhole effect greatly increases memory load which can, in turn, induce slips.

"Mistakes" are errors based on flawed reasoning or on misconceptions about how the equipment works. The use of automation requires that the mariner have equipment-specific knowledge. In order to use ARPA effectively, the mariner must understand the theory of operation of an ARPA, including such things as how different sensors feed into it, how that input is manipulated and displayed, and what constraints or limitations the system may have. Through this kind of knowledge, the mariner builds a "mental model" about how the equipment operates and how it will act under different circumstances. If the mariner's mental model of the ARPA is accurate, he or she will be able to use ARPA to its best advantage, knowing under what

conditions it can be relied upon and how to spot and resolve equipment errors. On the other hand, if the mariner holds misconceptions about ARPA operational capabilities, then the mariner is liable to misinterpret the data display and to rely upon it under conditions that do not warrant such reliance. For example, ARPA errors resulting from the incorrect initialization of the gyroscope or speed log may occur because the mariner does not understand that these inputs are used by the ARPA to calculate the speed and orientation of neighboring ships (flawed mental model). Such mistakes could lead the mariner into inappropriate or delayed maneuvers. Because many of these errors can be prevented through better equipment design or training, it is important to identify common errors and determine what causes them.

We can tap into flawed mental models and identify slips by examining the types of problems mariners have learning to use ARPA and by observing the types of errors made in operational use. Our study identified five common ARPA errors (Table 1) made by seasoned mariners.

**Table 1.**

Common ARPA Errors

- Incorrect initialization of gyroscope or speed log input
- Misinterpretation of true and relative motion vectors
- Misuse of ground stabilized mode
- Misinterpretation of trial maneuver information
- Failure to use CPA rings and relative motion vectors for trial maneuvers

## **PREVENTING ERRORS THROUGH IMPROVED EQUIPMENT DESIGN AND TRAINING**

How can these types of errors be avoided? Errors can be avoided through improved equipment design and through changes to current training and testing practices. The best way to prevent errors is through *human-centered equipment design*, that is, designs which work *with* users and complement their capabilities, rather than designs which work against users by hiding needed information or pushing users beyond their mental or physical limits. For example, one cause of several of the errors shown in Table 1 is misinterpretation of the mode the ARPA is in (true, relative, ground stabilized, or trial mode). The design of the ARPA does not make the mode sufficiently clear, relying on the mariner's already-overburdened memory.

*Continued*

Display designs that make the mode more salient or an automatic time-out feature which resets the display to a "standard" collision avoidance display (i.e., true or relative ) are just two potential ways to correct this problem.

The second way to avoid errors is through better training and testing of essential knowledge and skills. The Coast Guard R&D Center has developed techniques specifically for determining how automation affects mariner task and skill requirements. These techniques include cognitive task analysis, skills assessment, and error analysis. Using these techniques, we identified the knowledge and skill requirements which are essential to using ARPA and ECDIS. Training courses need to incorporate each of these knowledge and skill requirements to ensure that the student both understands the theory of operation and can perform the function effectively. Also, by making mariners aware of common error situations and training them to recognize and correct those errors, we can reduce the probability of such errors occurring and going unnoticed. The testing of automation-assisted shipboard functions must also consider both knowledge and skills. A recent CG R&DC project found that while paper and pencil tests may be sufficient for testing fundamental knowledge on the theory of operations, simulator testing is required to demonstrate the application of that knowledge as well as procedural skills. Simulator testing should cover all aspects of working with automated equipment, including setup and calibration, use of equipment features, interpretation of data and displays, comprehension of equipment limitations, and recognition and correction of equipment errors. The CG R&DC has developed lists of required skills and suggested learning objectives for courses on ARPA and ECDIS, and we would be happy to share these with interested industry groups.

## SUMMARY

Technologies such as ARPA, ECDIS, and IBS have the potential to aid the mariner, improving the mariner's awareness of the navigational situation and aiding the decision process for making course changes. But this potential can only be realized if the equipment has been designed properly and if mariners have the knowledge and skills to use the technology safely and effectively. Simply placing new technology aboard ships without ensuring, through training and testing, that mariners have adequate skills is both short-sighted and dangerous.

Task analysis and related techniques can be used to identify both the equipment design requirements to make the system more compatible with the mariner's needs and the set of knowledge and skills which the mariner must possess in order to use the equipment capably. By improving the design of shipboard equipment and developing more comprehensive training and testing on the equipment, we can improve the mariner's effectiveness and, ultimately, increase safety at sea.

\* This paper is based on the paper, "Evaluating Shipboard Automation: Application to Mariner Training, Certification, and Equipment Design," by Sanquist, Lee, McCallum, and Rothblum, and which was presented at the National Transportation Safety Board Public Forum on Integrated Bridge Systems, May 6-7, 1996.

Dr. Anita M. Rothblum is the human factors project manager at the Coast Guard Research and Development Center, 1082 Shennecossett Road, Groton, CT 06340-6096. Telephone: (860)441-2847.



---

# “Taking the Search Out Of Marine Safety”

by CDR Wayne Gusman and LT Tina Burke

Just as new technologies and science were developed and applied in the operational realm of the Coast Guard to take the “search” out of search and rescue missions, Coast Guard personnel in the “M” world are making significant strides in using new technologies and science to take the “search” out of marine safety and environmental protection activities. Minimizing the “search” portion of marine safety operations is important because it makes better use of the Coast Guard’s increasingly limited resources in the face of enormous current challenges and mandates. In today’s marine safety world, the application of science and technology are helping to target vessels for more efficient inspection and evaluation of material condition, and to capture windows of opportunity in time-critical response efforts, such as oil spill response. This article reviews these two specific Coast Guard efforts, and suggests that the application of this principle will continue to spread as the Coast Guard seeks to gain efficiencies through the expanded use of science and technology.

## PORT/VESSEL SAFETY (PREVENTION)

The search component involved in locating substandard vessels, and in finding discrepancies during vessel boardings, has been reduced by the Coast Guard through the application of more scientific methods of risk assessment and management.

In 1994, the Coast Guard implemented a vigorous Port State Control program for the inspection of foreign freight vessels visiting US ports. In a letter to all Captains of the Port and Officers in Charge of Marine Inspection dated April of 1994, the then Chief of Marine Safety, Security, and Environmental Protection, RADM Henn, USCG wrote, “As the numbers of U.S. flag deep draft



*Aerial view of the barge North Cape leaking oil in Block Island Sound, off Rhode Island's coast, in January of 1996. Photo by MST2 Paul Lonardo.*

vessels have declined, our nation has evolved from a flag state to a predominantly port state. Current estimates indicate that at any given moment there are fourteen foreign flag deep draft vessels transiting U.S. waters for every U.S. flag deep draft vessel.” Previously, foreign tank and passenger vessels had been subject to significant Coast Guard scrutiny. However, the new emphasis on foreign vessel inspection through the Port State Control program was “a logical and necessary movement to respond to changing threats to our ports and maritime environment.” This was one step toward improved risk management in the foreign vessel arena.

A greater breakthrough was made, however, when the Coast Guard developed and implemented targeting criteria to determine which vessels would be boarded. Before this system was devised, vessels were boarded and inspected according to mission performance standards based primarily on time considerations. For instance, under the old system, certain types of vessels were to receive designated exams at specific time intervals (i.e. every 6 months, annually, etc.). Under the old system, Coast Guard boarding officers were in effect randomly “searching” for safety discrepancies.

*Continued*



image based on the reflection of the energy from the target object. In the case of oil, the SLAR detects oil on the water because of the variation in roughness of the water's surface with or without oil on it. Specifically, the radar measures a reduction in radar backscatter resulting from the calming effect of oil films on small scale water waves. Consequently, in radar images, the oil covered areas appear dark since very little energy is being returned, whereas the oil free, wind ruffled ocean appears a grainy grey-white. The IR/UV sensor portion of the Aireye system further enhances the ability to detect oil

The new system utilizes a matrix of five characteristic categories to assess the risk of each vessel entering a U.S. port. These characteristic categories are vessel owner, flag, class society, boarding history, and vessel type, and the vessel receives points based on its characteristics (the riskier, the more points). The targeting regime allows Coast Guard boarding officers to concentrate their efforts on those vessels with higher probability of discrepancies. Over time, this strategy has positively influenced port and vessel safety using fewer resources than would have been required under a more "hit-or-miss" approach.

## ENVIRONMENTAL PROTECTION

A major Coast Guard mission is the prevention, detection, and control of pollution from oil. In recent years new technologies have improved the Coast Guard's ability to detect oil spills, especially at night. These technologies enhance the efficiency of environmental protection efforts in two ways. They allow oil spill cleanup activities to take place during nighttime hours, and they also enable Coast Guard units to actively survey areas for illegal oil dumping at night, a time when the risk of illegal oil discharge is greatest.

Two widely used systems for nighttime oil detection are the Aireye system and portable infrared cameras. The Aireye system includes two sensor subsystems which are called the Side-Looking Airborne Radar (SLAR), and the infrared/ultraviolet (IR/UV) Line Scanner. The radar, or SLAR, like any other radar, generates an electromagnetic signal and creates an

by providing multi-spectral information on the targets of interest. This allows such things as ships' wakes and kelp to be differentiated from oil slicks. Aireye technology began in the early 1970s, and today these systems are installed on designated Coast Guard Falcon aircraft. Other aircraft, while they do not carry the entire Aireye system, do carry separate components/sensors for night oil detection. For example, some C-130s are equipped with the SLAR, and certain helicopters are outfitted with independent infrared sensors, also called Forward Looking Infrared (PLIR) sensors.

In the 1990s the Coast Guard began to investigate the use of portable infrared sensors for oil spill detection. These sensors can conveniently be used onboard Coast Guard aircraft not already IR equipped, or on any aircraft of opportunity. Currently portable IR sensors are being used throughout the country and the Coast Guard's capability to detect and monitor oil at night continues to increase as personnel become trained and proficient in the operation of the sensors.

These technologies have become a critical component of removing the "search" from environmental protection activities, thereby increasing effectiveness and efficiency. During oil spill cleanup operations, night time detection capability will allow for activities, such as offshore skimming, to continue during hours of darkness. Rather than skimming during daylight and then searching for the oil the next morning to begin skimming again, the operation can run continuously, using these technologies to find the oil at night and direct the skimming assets appropriately. Since oil spreads at a very rapid rate, and becomes more difficult to recover the thinner and more



widespread the slick becomes, the ability to avoid time delays in cleanup operations has the potential to significantly increase cleanup effectiveness and efficiency.

Nighttime oil detection technology was used extensively during a recent major oil spill off the coast of Rhode Island. SLAR overflights were conducted each night during the week long spill to track the migration of the oil, a capability which was highly valuable. It allowed responders to keep a continuous check on the extent and movement of the slick, which was important due to precautionary measures that needed to be taken if the oil approached critical intakes in Narragansett Bay. It also saved precious time allowing skimmers to be on scenes in the area of the oil slicks, ready to begin recovery at first light. A portable IR camera was also used during this spill. The contribution that it made toward cleanup was limited, however, due to problems with its operation in cold weather. Lessons learned from this spill will be used to enhance the cold weather operability of this equipment.

Another application of this oil detection technology is the nighttime surveillance of waterways for vessels illegally discharging oil. Environmental criminals are more likely to discharge oil at night when “no one can see.” However, the Coast Guard can now “see” at night, allowing for surveillance at times when the likelihood of finding violations is greatest. The technology also helps with case documentation and successful prosecution of violations, IR camera video, for example, can provide critical evidence in the case of a slick emanating from a vessel offshore, whether in daylight or in darkness. The ability to obtain photo documentation might preclude the need to deploy an expensive CG surface asset to take oil samples, or rely solely on the statements of aircraft crewmembers as evidence of the violation.

Overall, these new technologies allow the Coast Guard to respond efficiently to environmental protection risk when the risk is greatest—when oil is in the water and is quickly getting away—or at night when the likelihood of illegal oil discharges from vessels is greatest.

## CONCLUSION

Recent Coast Guard organizational efforts to streamline its force structure have made it clearer than ever before that we need to develop new technologies and scientific approaches and apply their old ways of doing business. This article touches only the tip of the iceberg. Many other examples can be shown in which the Coast Guard is at work positioning its resources to address current risk, or analyzing the benefits of infusing technology to more efficiently execute marine safety and environmental protection missions. For instance, a study completed in July of 1995 by Mr. Michael Goodwin and Mr. Kurt Hansen of the CG Research and Development Center offered extensive results on Coast Guard efforts to evaluate new



*Petty Officer from MSO Providence (BM3 Donald J. Benware) conducting vessel inspection. Photos by YN2 John L. Joseph.*

technologies that might make the inspection/survey process more efficient or more effective. Some of the technologies being investigated include remotely controlled lights, video systems, fiber-optic video scopes, robotic manipulators, robotic climbers and walkers, acoustic and microwave imaging, thermography, and polarized light techniques. The investigation component of marine safety and environmental protection efforts is another prime target for new ways of doing business in the future.

In the final analysis it makes sense to apply targeting regimes to all marine safety functions in order to employ resources where risk and benefits are most pronounced. Through the resourceful use of science and technology, more and more Coast Guard personnel are getting a better chance to do this for the benefit of the public and industry alike.

About the Authors: CDR Wayne Gusman was currently the Executive Officer of Marine Safety Office Providence, Rhode Island. He has recently reported to the Eighth Coast Guard District for duty as Assistant Chief of the Marine Safety Division.

LT Tina Burke recently completed postgraduate training in environmental management at the University of Rhode Island, and is currently serving as Chief of the Coordination Branch, National Strike Force Coordination Center In Elizabeth City, North Carolina.

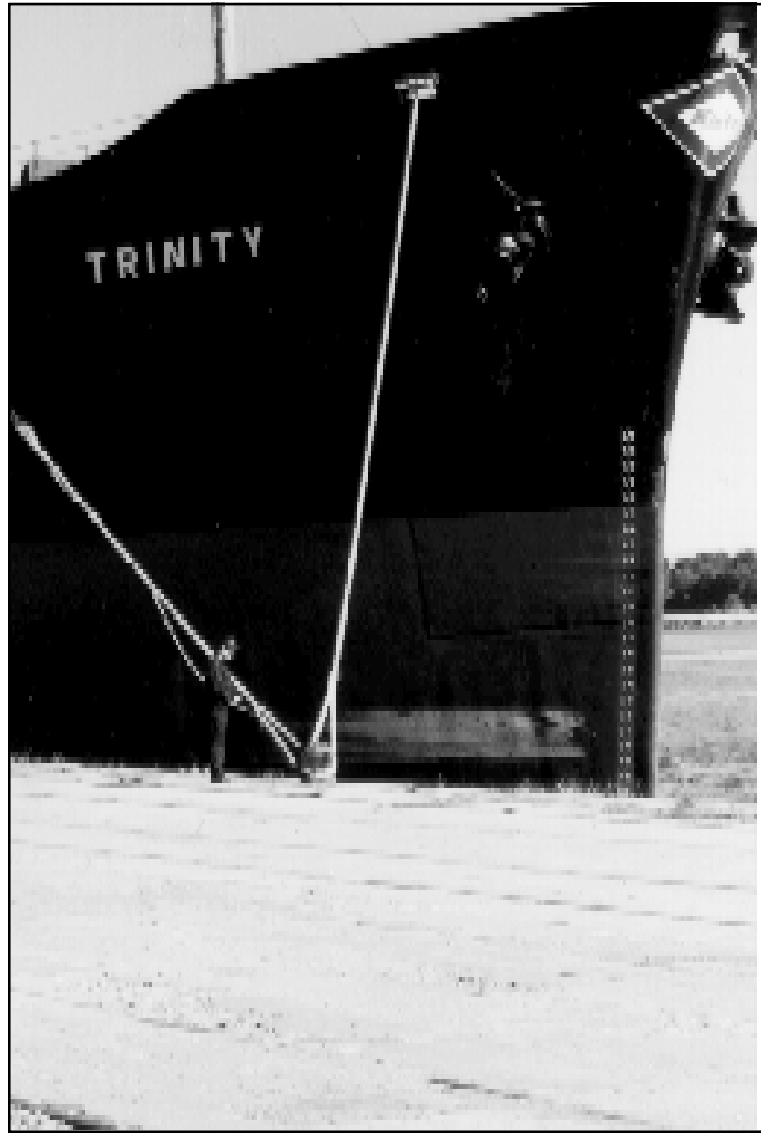

# Technology and Maritime Professionals Proactively Reduce Navigational Risks On Southeast Texas Waterways

By Captain Stephen Ford,  
P.O.R.T.S. Manager  
Texas A&M University at Galveston

LTRonaldBald, USCG  
Operations Officer  
U.S. Coast Guard Vessel Traffic Service Houston/Galveston

Figure 1

Mariners transiting the 70+ mile waterway complex bounded by the ports of Houston, Galveston, and Texas City are routinely affected by high winds, strong currents, low water levels, and sporadic shoaling. These conditions challenge the mariner's ability to control ships and barge-pushing towboats. Narrow dredged channels provide the only means of transiting the area and do not offer abundant room to avoid other vessels. The combination of these and other factors led to a total of 1,523 groundings from 1986 through 1995 as documented by the U.S. Coast Guard Vessel



*Two ships break to starboard as they prepare to meet in the Houston Ship Channel.  
Photo by QMI Scott Eriksen, USCG*

Traffic Service (VTS) monitoring the region. VTS loosely defines groundings for their statistical records as an interaction with the bottom which leads to the inability of the master to refloat the vessel at will. Fortunately, the soft mud bottom offers an extremely low risk of rupturing vessel and barge hulls. Wind, current, and low tide were given as the primary causes in 481 groundings equating to 31.6 percent of the total. The catch-all "operator error," which could involve any of these meteorological conditions, encompassed an additional 641 groundings or 40.3 percent.

Today, mariners are benefiting from the installation of several technological instruments. Over the past 12 months, National Oceanic and Atmospheric Administration (NOAA) personnel, members of academia, the maritime community, and the Coast Guard have acted in concert to acquire, deploy, and disseminate critical realtime weather, current, and tidal

information from a Physical Oceanographic Real-Time System (PORTS) and a satellite-feed weather center. This intelligence can provide every mariner with crucial advance data regarding meteorological conditions that will affect their vessels. Application of this information can reduce the associated navigational risks which should lead to a reduction of maritime accidents. The area of greatest concern in this region is the entrance to Bolivar Peninsula along the Gulf Intracoastal Waterway (GIWW). This area is one mile east of the intersection of the Houston Ship Channel and the GIWW. Strong broadside currents routinely affect towboats entering and departing the narrow cut. VTS statistics rank this area as having the highest occurrence of groundings over the last decade and the area has earned the highest percentage of overall groundings in each of the last nine years. The anticipated result of implementing

*Continued*

these technological systems is a reduction in the number of marine accidents in the Galveston Bay waterway complex. Particularly, all parties hope to see the number of groundings at the entrance to Bolivar Peninsula decline.

Efficient and sustainable development of accurate charts and modern navigation systems are required for safe marine transportation systems. A strong National Oceanic and Atmospheric Administration (NOAA) and U.S. Coast Guard are important components of navigation safety and technology. As America and the Houston port complex advance into the 21st century, the international competitiveness of our local industries will depend upon the effectiveness of our marine transportation system and its associated port infrastructure. Safety and informed maritime decision-makers add a real cost to the final price of retail goods. However, the cost of a maritime catastrophe thrusts a much greater cost upon the maritime industry, the retail goods and ultimately, society.

Every mariner fears being involved in a maritime accident. Groundings, collisions, and rammings can extensively damage the vessel, pollute the environment, or injure personnel. At a minimum, an incident will delay the vessel's transit which causes an unnecessary loss in efficiency which is certain to lead to a reduction in vessel revenue. Successful navigation requires the mastery of a vessel and her characteristics and must be accompanied with knowledge of waterway conditions. The fusion of these two distinct components must be accompanied by foresight and pre-planning for the intended vessel transit in order to avoid an embarrassing accident. Professional experience plays the greatest role in recognizing potentially devastating factors for the voyage. But experience must be accompanied with as much accurate and recent nautical information as possible if the vessel is to have an uneventful transit. In his opening paragraph of *The American Practical Navigator*, Nathaniel Bowditch states that a "good navigator gathers information from every available source ... constantly evaluates the ship's position, (and) anticipates dangerous situations well before they arise..."

Narrow, dredged channels, high traffic density, and waterway characteristics which vary from 7 mile reaches to 20 miles of continuous turns welcome mariners transiting the waterway complex. Even on a beautiful day with no wind, no current, and unlimited visibility, transits can be challenging. The only means for commercial ships and barge-pushing towboats to transit the area are the Army Corps of Engineers maintained channels. At a maximum width of 400 feet and a depth of 40 feet, these channels do not offer abundant room to avoid other vessels. Ships with

beams exceeding 100 feet each routinely meet, and safely pass at a closest point of approach of fifty feet. This feat is accomplished through precision shiphandling. As shown in figures 1 and 2, the vessels approach each other head-on, then simultaneously break to starboard when they reach a distance of approximately one-half mile apart. The ships pass each other using the hydrodynamic forces between the vessels and the banks before regaining their positions along the centerline. Shallows of less than ten feet lie within 600 feet of the channel centerline. In most locations, localized high winds, strong currents, low water levels, and sporadic shoaling routinely stress the Galveston Bay mariner's ability to control their ships and towboats.

The U.S. Coast Guard Vessel Traffic Service (VTS) Houston/Galveston monitors all waterborne traffic as required by federal law. Through the first 100 days of 1996, the VTS has logged a daily average of 347 ships, towboats, and other vessels into the Vessel Movement Reporting System while monitoring 265 daily ferry boat transits. The level of VTS traffic has

**Figure 2**



*Two ships meeting in the Houston Ship Channel. Closest points of approach are often fifty feet. Photo by QMI Scott Eriksen, USCG*

Figure 3

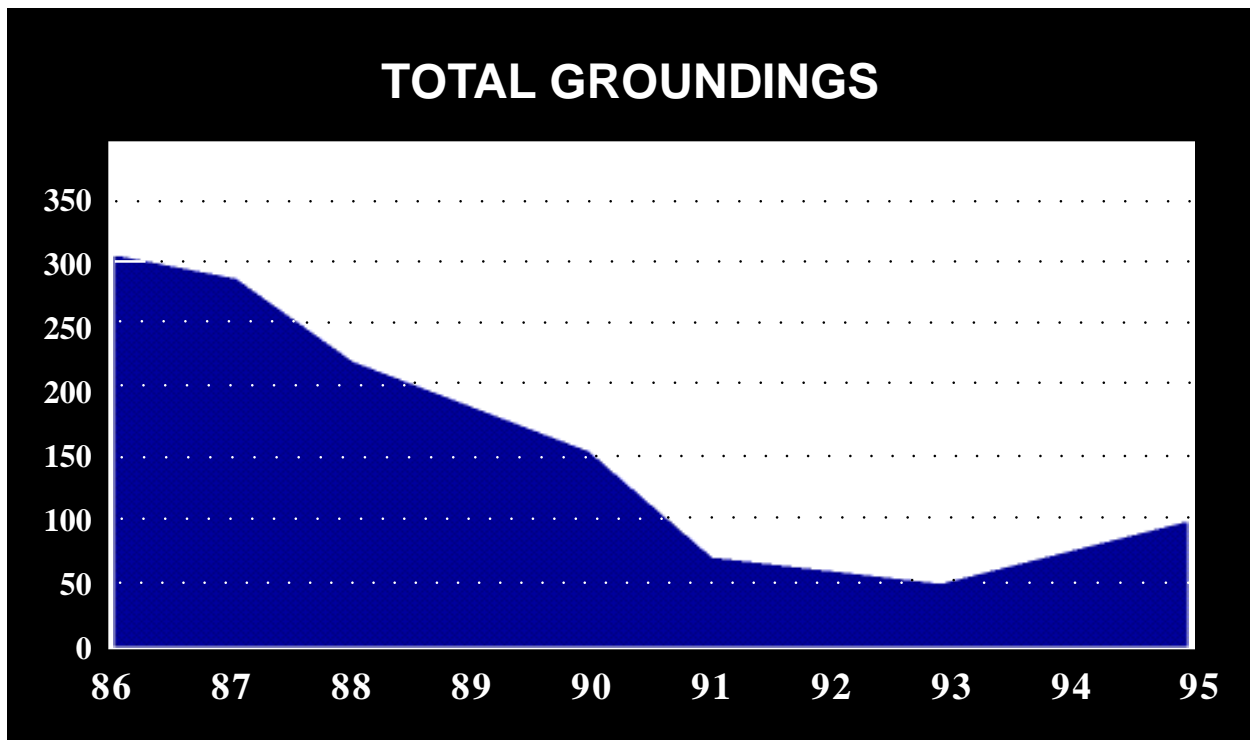

maintained a steady 2.5 percent annual growth in vessel movements since 1986. The size of the vessels calling on the ports also continues to grow. Newer vessels carrying more cargo continue to expand the operating envelope of the waterways. However, throughout this period of increasing traffic, the waterway dimensions have not changed. Today, little room exists for vessels to maneuver out of harm's way in the event unexpected circumstances arise.

Figure 3, Total Groundings, conveys the significance of the 1,523 Galveston Bay groundings between 1986 and 1995 as documented by the local VTS. VTS defines groundings for their statistical records as "an interaction with the bottom which leads to the inability of the master to refloat the vessel at will." Fortunately, the regional soft mud bottom contains an extremely low risk of adverse consequences resulting from the event. Wind, current and low tide were the primary causes of 481 groundings during the period and represent 31.6% of the total groundings. Forty percent or 641 groundings were attributed to the catch-all "operator error" which could include any of the meteorological conditions.

The Galveston Bay basin is strongly influenced by the passage of local weather fronts. Figure 4, Galveston Bay Water Levels during northerly winds, illustrates meteorological impact on the Bay on April 15, 1996. Thus, tidal table predictions which are

derived from solar and lunar information are accurate only 50% of the time. Figure 5, March 18, 1996 Frontal Passage Impact, conveys the effect on the local water levels by the passage of a cold front involving the breakup of a barge and causing a significant fuel oil spill. The three foot drop in the water level in eight hours, observed through figures 4 and 5, caused very high currents within the bay. From these examples, it is apparent that both the water level and current parameters have significant daily effect on the local marine transportation system.

Beginning in 1989, a cooperative effort between the local maritime industry's Houston Galveston Navigation Safety Advisory Committee (HOGANSAC) and the Coast Guard yielded many positive changes in defining the waterway through aids to navigation. The late Coast Guard Captain John Witherspoon, while commanding officer of the Houston/Galveston VTS, gathered regional statistics which provided a locational basis for cooperative industry-Coast Guard aids to navigation placements and changes. HOGANSAC leader Mr. Milt Rose in concert with VTS representatives like Commander Michael Hunt oversighted and fine-tuned aids to navigation placements based on statistics and vessel operator feedback. These strategically placed buoys and lights have virtually eliminated groundings in

*Continued*

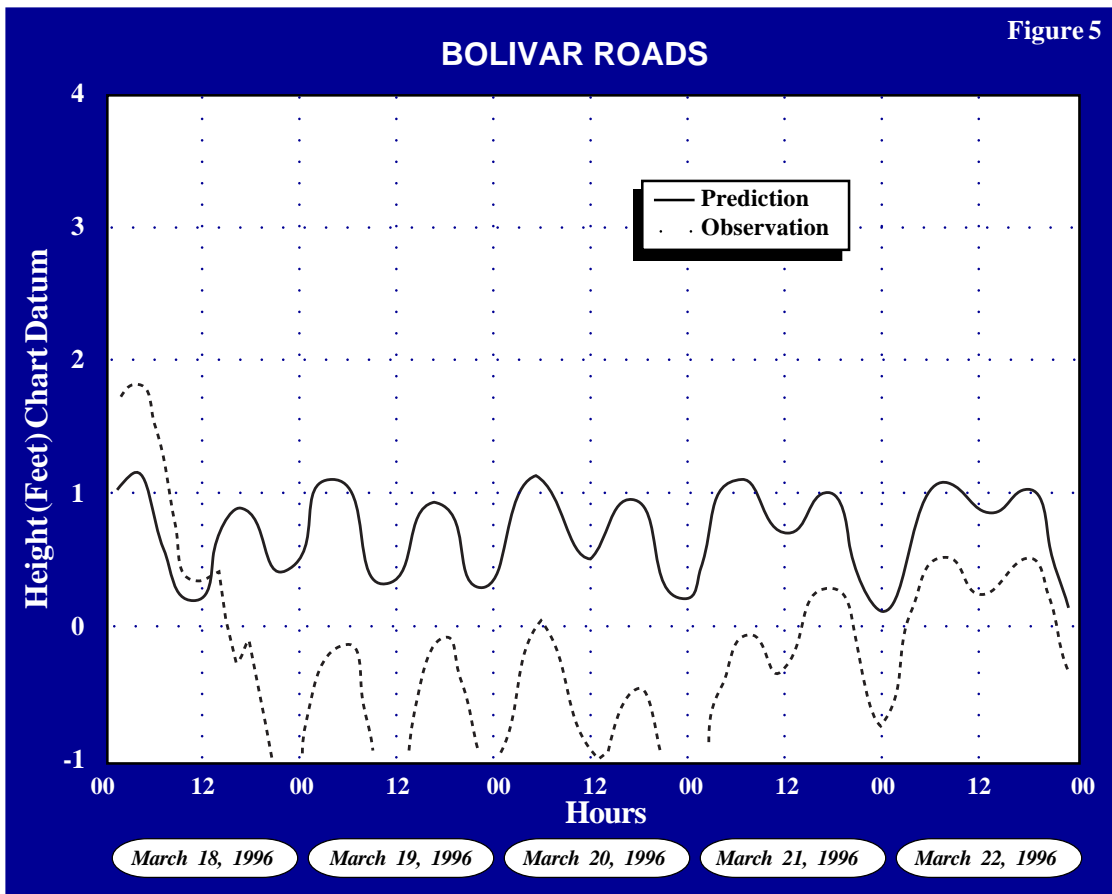
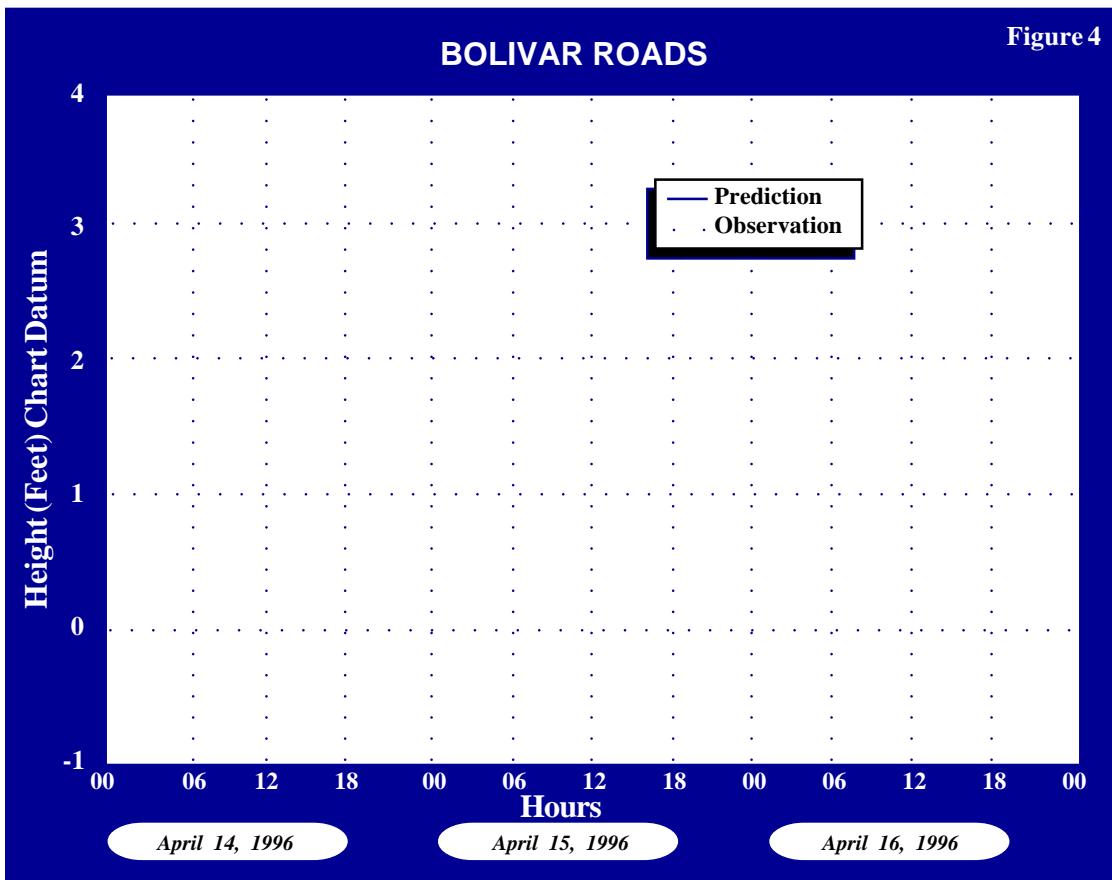

several areas. The results are best seen when comparing groundings between the first and second halves of the last 10 years. From 1986 through 1990, the VTS documented 1,165 groundings and 523,522 vessel transits (figures 3 and 6) equating to one grounding every 449.4 transits. Over the next five years, with substantial improvements in waterway definition occurring during 1991, the VTS documented groundings fell to 358 while transits rose to 586,674. This period yielded one grounding every 1,638.7 transits or an improvement of 264 % from the previous five years. While this is a tremendous improvement, every marine accident can be a catastrophe. Every member of the maritime community in the Houston, Galveston, Texas City complex continues to desire to give the mariner all the information and technology needed to conduct a safe transit. With the waterway boundaries better defined, it became apparent the mariner needed real-time information on environmental factors in order to further reduce the incident statistics.

In 1989, HOGANSAC, under the leadership of Captain Jim Baker and Mr. Ted Thorjussen, convinced NOAA to evaluate the effectiveness of the local Tide Table predictions. This study confirmed local concerns about the accuracy of the table predictions. As a remedy, HOGANSAC sought the

installation of current meters and water level devices in Galveston Bay.

During 1990 - 1991, a NOAA National Ocean Service (NOS) team tested a prototype Physical Oceanographic Real-Time System (PORTS) in Tampa Bay. Subsequently, NOAA prepared a report to the U.S. House of Representatives in June, 1994, discussing the benefits of a PORTS in several waterways including Houston/Galveston. By 1994, strong backing from local maritime industry officials along with Congressional assistance helped secure an initial NOAA investment of \$750,000 for the procurement, installation, and one year of operation and maintenance of three Acoustic Doppler Current Profilers integrated with five meteorological and water level sensors in a real-time Galveston Bay system for the distinct purpose of enhancing marine transportation safety. These profilers combine to provide widespread coverage of 50 miles of area currents, tidal levels, and weather information. In 1995, the Marine Transportation Department of Texas A&M University at Galveston (TAMUG) took the lead and is now the base for the Houston/Galveston PORTS' initial year. An ADCP or Acoustic Data Current Profiler (figure 7) is a sonic "look-up" device buried in the sea bottom to measure the doppler shift

*Continued*

**Figure 6**

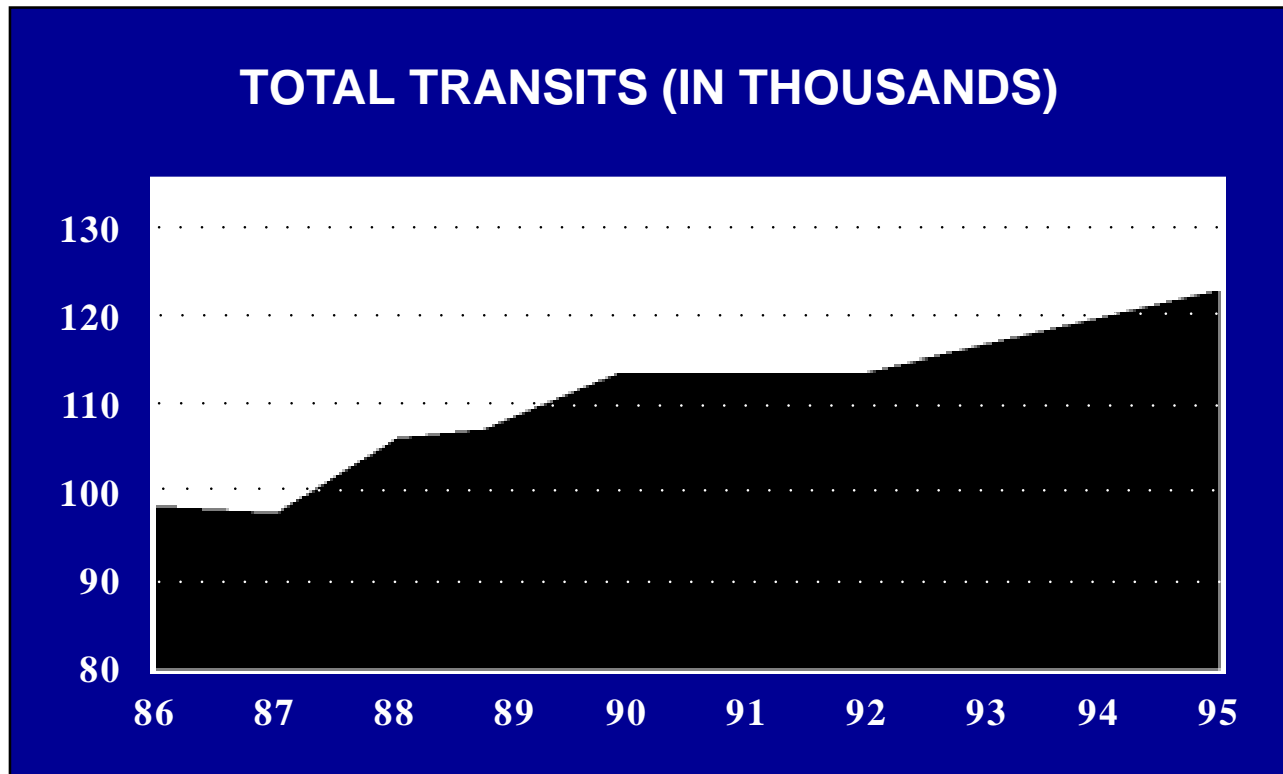



ADCP or Acoustic Data Current Profiler. Photo by Captain Stephen F. Ford.

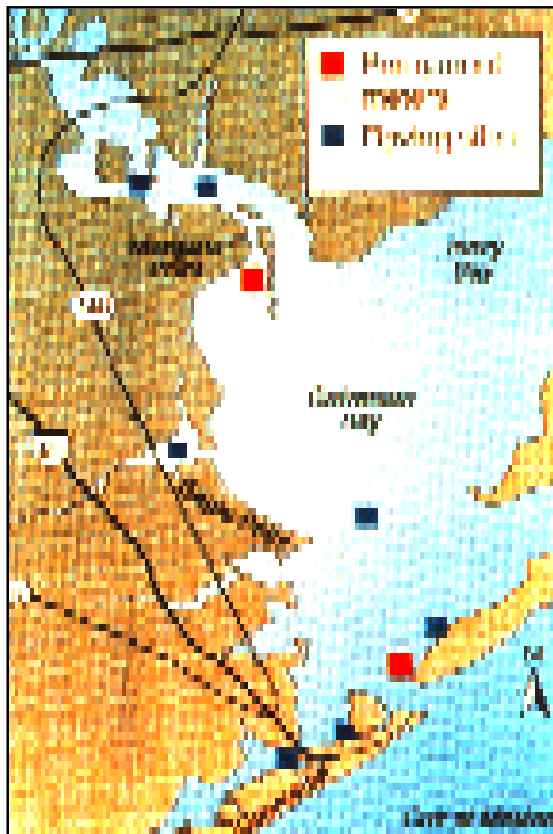

Galveston Bay PORTS Instrument Sites.  
Photo courtesy of Galveston Daily News.

Figure 8

of sound waves and thus measure the current at different levels. With the aid of the Galveston-based Coast Guard Cutter CLAMP, two profilers have been permanently installed near the intersection of the Houston Ship Channel entrance and the Gulf Intracoastal Waterway (GIWW); and near Morgan's Point at the upper end of Galveston Bay. As per figure 8, Instrument Sites, a smaller, portable profiler will be rotated between several sites in the waterway to document conditions and changes over time. Its initial site is near Redfish Bar. Information from the three profilers is received every six minutes at TAMUG. A complex installation of four computers processes the data and makes it immediately available to the general public via telephone with the aid of a voice synthesizer. The data is also immediately available via Internet and personal computer (PC) modem. Figure 9, PORTS Data Display, portrays the real-time information available from the system. For a real-time demonstration of PORTS technology, interested parties are invited to establish voice contact at (409) 740-4975 or internet contact at <http://www.tamug.tamu.edu/mart/ports.htm> or telnet [ceob.nos.noaa.gov](http://ceob.nos.noaa.gov) (login:hgports). Remote real-time PORTS displays are located at the Houston/Galveston VTS and Galveston Marine Safety Unit (MSU) offices and at both the Galveston-Texas City Pilot and



Figure 9

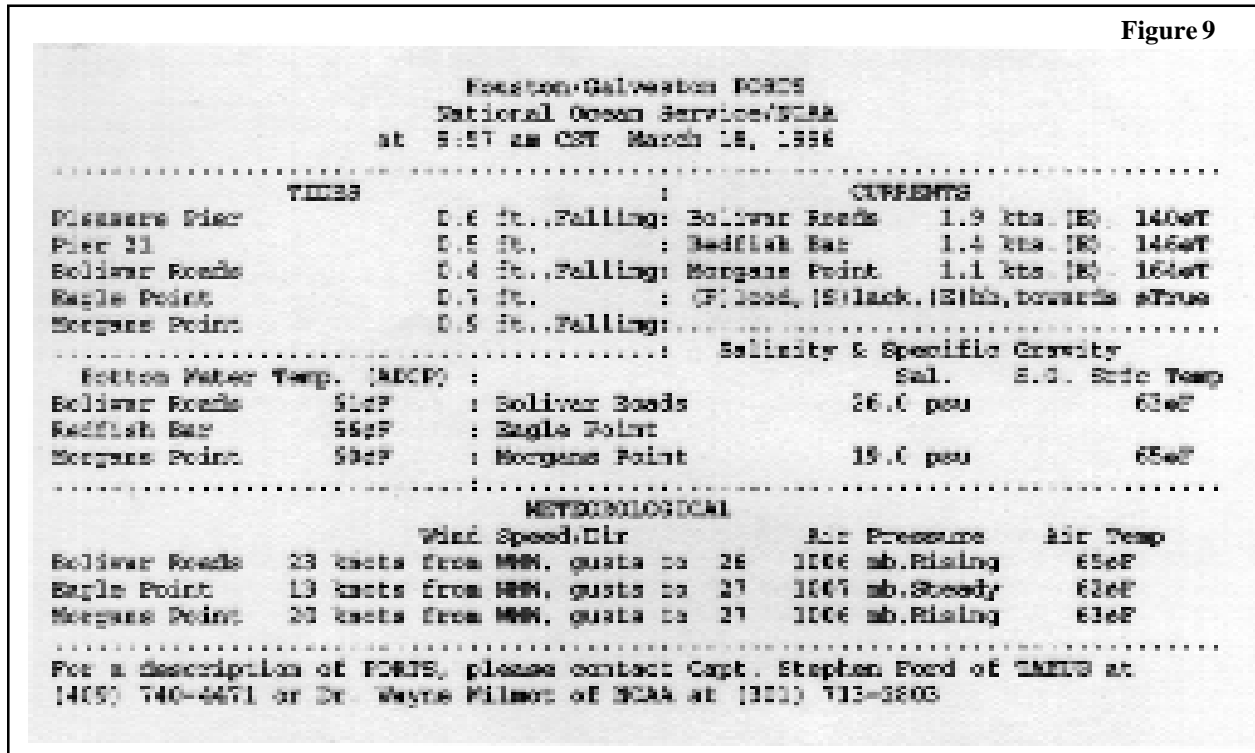

Houston Pilot offices. The VTS disseminates the information to underway vessels while the pilot office continuously updates its members. MSU Galveston has already utilized the PORTS to predict and contain two significant spills during March, 1996. When necessary or desired, the data can also be accessed by underway pilots via cellular phone.

As research at TAMUG progresses, it is anticipated that Internet, PC modem, and fax users will be able to receive pictorial displays of the numerical PORTS data in a fashion similar to figure 10. Further research efforts envision that ships with the right computer equipment and vector electronic charts (figure 11) or "Smart Charts" will receive real-time views of their nautical surroundings with complete details of the sea bottom including actual channel depth and real-time current velocity and direction. Researchers at TAMUG are also investigating the utilization of PORTS data in ship simulators and virtual reality charts.

The present PORTS installation will reduce navigational risks in the Galveston Bay complex by providing local mariners with accurate, real-time information. In essence, PORTS is adding more science to the seaman's eye in order to make waterborne commerce safer, easier and

cheaper in a sustainable fashion.

The VTS has also installed a satellite weather system at their Galena Park based Vessel Traffic Center. This system serves as a perfect companion to the real-time PORTS data by supplying current and forecasted weather information for the entire country. VTS' satellite system provides the resources for advanced warning of severe weather conditions and developing reduced visibility. The information is evaluated by the VTS and shared with all marine interests in order to

*Continued*

Figure 10

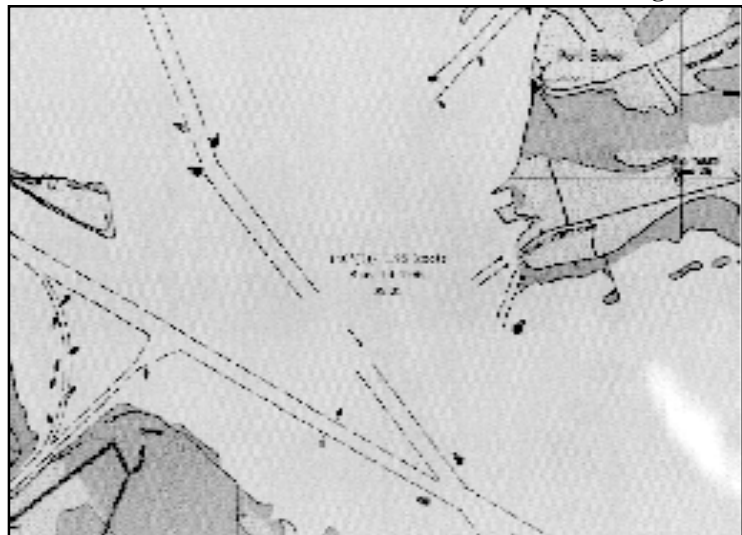

support their individual decision making processes.

The anticipated result of these new systems is a reduction in the number of marine accidents in the waterway complex. Particularly, all parties hope to see the number of groundings at the entrance to Bolivar Peninsula decline. This area is one mile east of the intersection of the Houston Ship Channel and the GIWW. As depicted by figure 10, PORTS' Bolivar Roads Display, strong broadside currents routinely affect towboats entering the narrow cuts on both sides of Bolivar Roads. As shown in figure 12, Bolivar Roads Groundings, this area accounts for 241 groundings over the past 10 years, and ranks as having the highest occurrence of groundings over the last decade. Bolivar Roads is the locale of the highest percentage of overall groundings in each of the last nine years. Figures 13 and 14 display the local towboat operations on the GIWW. The GIWW is heavily traveled by towboats calling on the area facilities as well as those transiting to and from other ports of call. Groundings at the Bolivar Entrance periodically block the entire

waterway which causes dozens of vessels to wait until the tow is able to work her way off the bottom. This channel blockage not only affects waterborne commerce and economics, but also must be ultimately borne by the consumers of the impeded cargo. With PORTS as an added aid to marine transportation

*Continued*

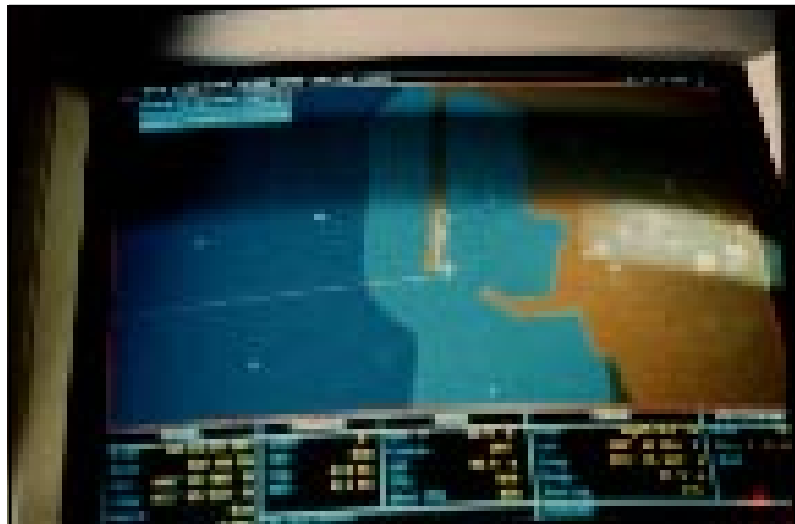

*Vector Electronic Chart. Photo by Captain Stephen F. Ford.*

**Figure 11**

**Figure 12**

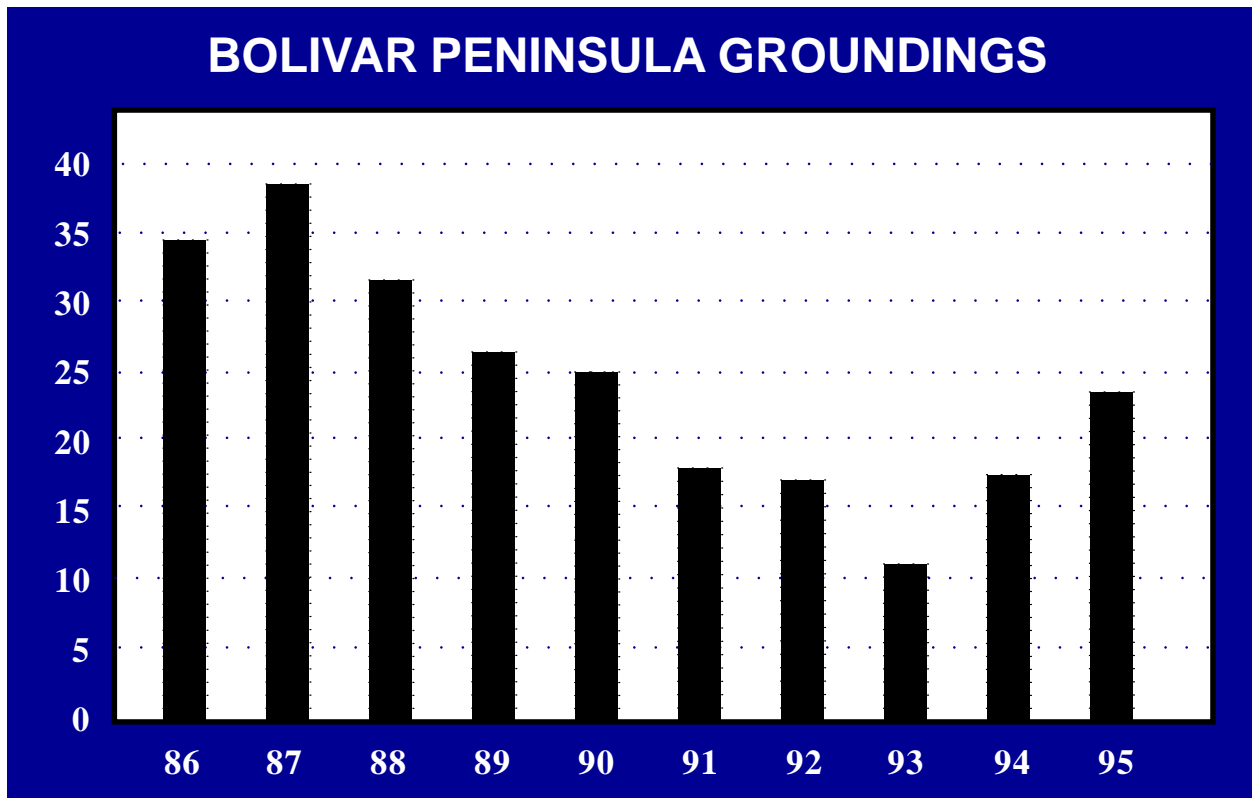



*A towboat crabs its way into the Bolivar Peninsula entrance. Photo by QMI Scott Eriksen, USCG.*

**Figure 13**



*Gulf Intracoastal Waterway Towboat Operations. Photo courtesy of Kirby Corporation.*

**Figure 14**

---

safety, fewer groundings should occur which should reduce the lost time of vessels and increase efficiency and productivity of local commerce. After the October, 1995, Bolivar Roads current meter installation, VTS began passing current velocities when they reached critical levels determined by local towboat operating company representatives. During the months of February and March, 1996, only two groundings occurred at the Bolivar Entrance. This is a 54.6% decrease when compared with the historical annual average of 4.4 during these two months of the year. At present, the sample size of this comparison is too small to declare that the statistics will be valid over a longer period of time, but initial maritime industry reaction is optimistic. Nonetheless, this early indication does portray the benefits the technological advancements of PORTS and the satellite weather center can have on the area. If early indications are accurate, the equipment and technology had an immediate impact and will provide major contributions to Houston, Galveston, and Texas City mariners. Future statistics are expected to continue to validate that technology and maritime professionals can interact to proactively reduce navigational risks on their local waterways.

## ABOUT THE AUTHORS

Captain Stephen F. Ford is a 1970 graduate of the U.S. Merchant Marine Academy with a 1978 M.B.A. from the University of Houston. He is a Master Mariner with fifteen years seagoing experience in coastal and international tanker trades. Past vice-president of a U.S. flag shipping company and past Head, Marine Transportation of Texas A&M University at Galveston. He now serves as the PORTS Manager of the Houston-Galveston system. Eight years service on NAVSAC and almost twelve years on HOGANSAC plus three years on the Houston Pilot Review Board amply qualifies him for his PORTS participation and active Maritime Expert and Consultant assignments. Captain Ford constructed the first electronic chart in 1976 and continues to lead research and development in the dynamic field of Electronic Chart Display and Information Systems (ECDIS).

Lieutenant Ronald J. Bald of Closter, New Jersey, is a 1987 graduate of the U.S. Coast Guard Academy with a 1995 Master of Arts degree in Public Management from the University of Houston - Clear Lake. He has served on active duty for the last nine years in the Houston/Galveston region. His duty assignments include Operations Officer aboard the Coast Guard Sea-Going Buoy Tender BUTTONWOOD, Coast Guard Group Galveston aids to Navigation Officer, and Operations Officer for Vessel Traffic Service Houston/Galveston. He will depart the area later this year for Alameda, California, and a tour of duty aboard the Coast Guard High Endurance Cutter BOUTWELL.



---

# USCG R&D Center Conducts Research in Tactical Oil Spill Surveillance Technology

By Gary L. Hover

Tactical oil spill surveillance technology can provide information that helps cleanup forces do a more efficient job. Types of tactical information required include the location(s) of oil within an area of immediate interest, slick thickness, and state of oil weathering. Accurate tactical information can be used to direct oil skimming operations and to help determine what alternative countermeasures, such as dispersing application and in-situ burning, may be appropriate. Ideally, tactical oil spill sensors should be readily available to provide real-time information in a day/night, all-weather operating environment.

Since 1991 the R&D Center has been conducting research in a variety of oil spill surveillance technologies. Two of these technologies, infrared (IR) imaging and microwave radiometry, are of particular interest to the problem of improving the USCG's tactical spill surveillance capabilities. These technologies cover both ends of the "technical risk" spectrum. At one end of this spectrum is proven, commercially-available IR imaging technology. Infrared imagers are already being used to support Coast Guard oil spill response operations and need only be refined to improve their utility in this mission. At the other end of the spectrum is a new device called the frequency scanning microwave radiometer, or FSR. The FSR measures radio-frequency energy from oil-covered water and analyzes this signal to determine how thick the oil layer is. Looking to the future, it is possible that one day these two sensor technologies could be combined into an affordable tactical oil spill surveillance system that provided better information than could either sensor operating alone.

## INFRARED EVALUATIONS

Much like the personal computer industry,

makers of infrared imagers have substantially improved their products in recent years. It is now possible to purchase a wide variety of compact, lightweight portable IR imagers off the shelf. These imagers, which can be used to observe oil spills from almost any aircraft of opportunity, can greatly improve the timeliness and efficiency of Coast Guard oil spill response by making it possible to track oil slicks and direct cleanup operations at night, even if IR-equipped Coast Guard aircraft are unavailable. Under these circumstances, the challenge for the R&D Center was in identifying the specific types of portable IR systems that would best supplement the Coast Guard's limited number of forward-looking infrared (FLIR)-equipped aircraft in the tactical spill surveillance role. Equally important was the need to understand how reliably IR devices can detect oil, to determine what other substances might appear similar to oil in IR images, and to identify sensor design and operator training issues that needed to be addressed.

Two field evaluations conducted by the R&D Center have compared the imaging capabilities of several commercially-available, hand-held IR sensors to those of the Coast-Guard's aircraft-installed FLIRs. The first was conducted in May 1993 at a military base in Ontario, Canada. This experiment, hosted by Environment Canada, offered an opportunity for the Coast Guard to test three of its infrared-equipped aircraft and three portable IR systems against known oil slick targets in a specially-constructed outdoor tested. The second field test was conducted in November 1994 over the naturally-occurring oil seeps off Santa Barbara, California. During this second field test a Coast Guard helicopter flew over the oil seeps and imaged them with its own installed FLIR system while four hand held IR imagers were operated in shifts from an open side door.

After the May 1993 experiment the Eighth Coast Guard District (New Orleans, Louisiana area)

*Continued*

purchased a portable IR imager to use and evaluate during actual spill response operations. A very notable spill at which this system was employed was the MORRIS J. BERMAN tank barge grounding off San Juan, Puerto Rico in January 1994. The nighttime image shown in figure 1 depicts oil escaping from the grounded barge, with the oil appearing cooler than sea water in the black is the hot IR image. Pumps running topside on the barge deck appear as hot objects. Since then, use of portable IR imagers for tactical oil spill surveillance has grown considerably within the Coast Guard, and new equipment has been purchased by many Coast Guard districts for this purpose.

Another example of the USCG's use of IR for tactical surveillance is taken from an oil spill that occurred on the Delaware River near Philadelphia, Pennsylvania in July 1994. A USCG HH-60J helicopter with its gimbal-mounted FLIR 2000 system was dispatched to provide night surveillance of the spill. Figure 2, obtained at 0230 local time, shows an

IR view of the leaking tanker vessel KENTUCKY moored at a pier with its associated oil slick flowing down river. Without the aid of the FLIR-equipped helicopter, response units would not have been able to monitor the extent and movement of this spill until after daybreak.

In addition to evaluating the newest portable IR technology, a side benefit of this project has been to develop a better understanding of the oil spill surveillance capabilities already offered by the USCG's existing airborne FLIR resources. Equally important are the operator training issues and imager design factors that were identified and documented as a result of this work.

## FSR DEVELOPMENT AND TESTING

The FSR project explores an innovative concept in passive microwave radiometer design that

Figure 1



Nighttime image of oil escaping from grounded tank barge.

involves scanning a wide frequency band to improve the accuracy of oil slick thickness estimation. This sensor design, referred to as a frequency-scanning radiometer or FRS, also provides data that may prove useful in estimating the degree to which an oil slick has emulsified due to weathering. The design is an improvement over past radiometer systems which observed microwave signals at only one to three fixed frequencies. Whereas, fixed-frequency radiometers are very susceptible to measurement errors, the FSR requires only reasonable accuracy and a straightforward curve fitting procedure to determine the thickness of uniform oil layers. Unlike the portable infrared imagers, however, the FSR concept is unique and represents a completely new instrument design that is not now commercially available.

In 1992 the R&D Center contracted with the Massachusetts Institute of Technology (MIT) Lincoln Laboratory to develop and laboratory test

the FSR concept for measuring oil slick thickness. A laboratory prototype FSR operating in the 26 to 40 GHz band was built and initially tested with several types of oil at various uniform layer thickness. Figure 3 shows a photograph of the laboratory prototype FSR along with a schematic diagram for the instrument and a sample data plot. As illustrated in figure 3, these uniform-layer measurements matched very well with theoretical predictions, prompting additional measurements with non-uniform oil layers and water/oil emulsions. Many of the non-uniform oil layer measurements appeared to reflect an average of the layers present within the FSR antenna footprint. As expected, emulsions and non-homogeneous oil layers tended to cause a general rise in brightness temperature across the entire FSR band, providing an indication of weathered oil. The laboratory phase of FSR testing was successful enough to warrant larger-scale measurements in a wave tank.

*Continued*

**Figure 2**



*Night IR image of oil slick near TN KENTUCKY on the Delaware River*

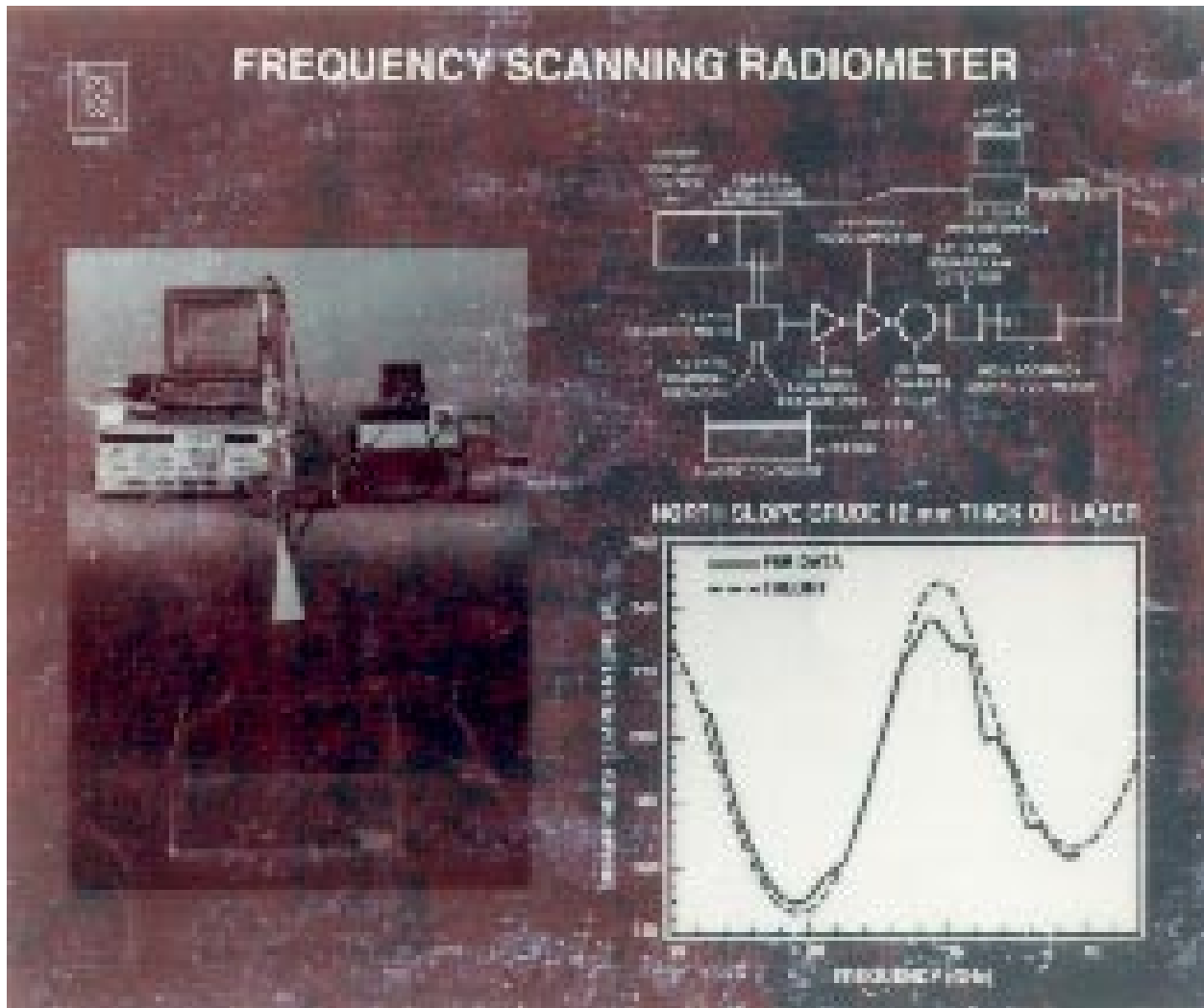

Laboratory prototype FSR with sample data plot

Figure 3

In October 1994, the FSR was ruggedized, repackaged, and brought to the Oil and Hazardous Materials Environmental Test Tank (OHMSETT) facility in New Jersey for a two-week data acquisition experiment. A variety of petroleum products ranging from diesel fuel to crude oil and emulsions were measured at various thickness and simulated sea states. Analysis to the experiment data indicates good agreement with the laboratory results under calm conditions, but improvements will be needed to produce reliable results in the presence of waves. More development and testing will be required to fully determine the operational utility of the FRS concept.

## FUTURE DIRECTIONS

### IR:

While IR technology is already proven and commercially available, improvements could be made

to the Coast Guard's existing portable imagers that would make them much easier to use in the dynamic airborne environment. New, uncooled IR detectors are becoming available that can substantially reduce the size, weight, cost and power consumption of portable IR imagers. These should be evaluated by the various operational Coast Guard programs that could benefit from widespread availability of portable night imaging technology. Improved methods of annotating the image data and transmitting it to the user would also be beneficial. Training is needed to provide sensor operators and end-users with the skills required to accurately interpret IR imagery and discriminate false targets from those of genuine mission interest.

### FSR:

An operationally-practical FSR would require much faster data acquisition speed to keep pace with a moving aircraft. A faster instrument has been



---

designed but has not yet been built or tested. An operational FSR would also likely need a second channel at higher frequencies to more effectively distinguish among oil thickness from a few tenths of a millimeter to 3 mm. The issue of what spatial resolution is required in the oil thickness data is one that requires coordination between the sensor designer and spill response operations personnel.

***Integration:***

Assuming that an operationally-viable FSR can be constructed, how might one be integrated with IR sensors to provide a more robust tactical oil spill surveillance capability? A simple strategy would involve using a grumbled, gyro-stabilized FLIR to guide an FSR-equipped aircraft to oil slick areas of interest. A second IR imager would then provide a strip-map to the end-user which could be annotated

with important mission data and thickness profile information obtained from the FSR and infrared greyscale measurements. This hybrid product would provide response units with a more completed tactical picture than can now be delivered. The challenge is to put the concept into practice!

**ABOUT THE AUTHOR**

Gary Hover has worked on numerous U.S. Coast Guard remote sensing projects in the area of search and rescue, law enforcement, ice reconnaissance and oil spill surveillance since 1979. He presently works as a Senior Research Engineer in the Marine Operations Technology Division at the USCG R&D Center.



*Continued*

# PTP at Work

Prevention Through People (PTP), the Coast Guard's program to address the people side of safety, continues to forge ahead. The Coast Guard has just published the PTP Strategic Plan booklet, a guide explaining PTP. The booklet illustrates the vision, principles and goals of PTP through examples of Coast Guard implementation and industry lessons learned. The Strategic Plan itself is intended to be universal so that any organization committed to quality management and continuous improvement can find it compatible to its own organizational philosophy. It is designed to be adjusted and tweaked towards the needs of each group for best implementation. The intent of PTP is to foster a cultural change that focuses on the human element to not only reduce casualties and pollution but also increase reliability and efficiency in maritime operations. Its success rests on the committed involvement of everyone.

The PTP concept supports the people-focused safety efforts that have been initiated at Coast Guard field units and in the marine industry. But PTP still embraces the technological side of ship safety. What makes PTP unique is the extra step it takes beyond basic design to include the human element. Engineers and designers

typically ask, "Will it work?" PTP asks, "**How** will it work **with people**?" PTP requires a systematic approach that considers interaction of technology and people. PTP focuses on awareness of the human element to reduce casualties and pollution incidents.

The following are summaries of three such efforts. If your unit or organization has had a PTP success that you would like to share, or if you'd like to receive a copy of the PTP Strategic Plan, please contact CDR Mark VanHaverbeke, Human Element and Ship Design Division, in Coast Guard Headquarters at (202) 267-2997.

## **MSO ST. LOUIS**

At Marine Safety Office St. Louis, an initiative called the Passenger Vessel Safety Program is creating partnerships between the Coast Guard, vessel operators, and state, community, and local response organizations. Through this Coast Guard sponsored program, these groups are working together to ensure the safety of passengers and crew on large inland passenger vessels, particularly casino vessels. These boats carry approximately 17 million people per year. Often these passenger vessels are the largest vessel operating in an area. The *Showboat Branson Belle*, a dinner theater excursion vessel, which operates on Table Rock Lake in Southwest Missouri, is 240 feet long. The next largest



vessel is about 80 feet. This size discrepancy can make towing or similar evolutions much more difficult.

Their program's four phase approach, which centers on Outreach, Training, Planning and Drills, applies the PTP philosophy of focusing on people in casualty prevention. The Outreach phase involves writing letters to emergency service organizations, state governors, and state gaming commissions as well as providing testimony at licensing hearings and media interviews - making the vessel owners and local officials aware of their responsibilities and ensuring that safety issues are considered in their decision to allow large passenger vessel operations. Training involves fire and safety seminars conducted for local response organizations and vessel operators to facilitate rapid, safe and efficient response to casualties. Developing vessel and shoreside contingency plans for drills involving vessels and local emergency responders comprises the Planning phase. The final phase includes operational drills conducted to exercise the emergency response system and identify shortfalls.

Several drills have been conducted which allowed vessel and response personnel to combine their efforts and prepare themselves to react effectively and efficiently to a casualty. While the results have been encouraging, a few problems have been uncovered. The main difficulty encountered in the drills has been communications

between the ships' Master and crew, the responding emergency teams, and the Coast Guard due to the different frequencies used by the various parties. In response, MSO St. Louis is developing a Harbor Emergency Plan to address this issue and others such as divisions of authority and command. Lt. Paul Dittman, former Planning Department Chief, MSO St. Louis, has commented that the Coast Guard's primary effort in this plan is to act as a mediator between the riverboats and the local governments and emergency response agencies. Most recently the MSO has conducted exercises with the Harrah's *North Star* in Kansas City, Missouri, according to LT David Baugh, Chief, Program Development and Administration Department. The vessel operators and emergency response organizations have reacted positively to the Coast Guard's efforts to mediate contingency plans between the riverboats and their local emergency response organizations.

## MSO PORTLAND

MSO Portland, Maine has been developing visual aids to convey safety concepts to fishermen. In addition to one-page "safety alerts" (some of which have been posted on the NMC home page), MSO Portland has developed two training aids, a set of models which demonstrate the stability impacts of flooding and a

*Continued*





damage control trainer.

The stability model set consists of three fishing vessels, each about two feet long and having the same hull form, but with variations in the subdivision: one model has none, one has fully intact watertight bulkheads, and one has watertight bulkheads which have been compromised by holes. Each model has a hole on the bottom in way of the lazarette, simulating a common flooding problem. The deck of each model is made of plexi-glass which allows the progress of the flooding to be observed. The three models are placed in water tanks simultaneously. While the flooding race is on, the presenter discusses the causes of flooding and various aspects such as free surface and down flooding angle. The speed with which the first model reaches its down flooding angle, and how quickly it capsizes, is a real eye-opener.

The damage control trainer project tackles the dilemma of what to do in a flood situation. Designed to recreate eight common flooding risks of that area, the trainer package provides a graphic presentation of basic damage control procedures. Some of the flooding risks highlighted during the program include a small hull beach, damaged stern tube packing, and damaged rudder port fitting. In addition, the trainer can also provide lessons in advanced areas such as combination plug/patch damage control techniques. By increasing awareness and providing demonstrations on flooding risks, MSO

Portland provides an essential safety measure to an area where flooding is a common work hazard. For more information on how to receive the small vessel damage control trainer free of charge (to mariners in the northern New England area), contact MSO Portland.

The commitment of MSO Portland to establish a safer working environment was recently recognized on a formal note. The MSO was awarded the Vice President's National Performance Review Hammer Award for their development of the stability model. Jeff Ciampa, the Fishing Vessel Safety Examiner at MSO Portland, also received a Silver Medal, the Secretary's Award for Meritorious Achievement, for his work in promoting the Coast Guard's Commercial Fishing Vessel Safety program.

## **MSO HONOLULU**

In the beautiful Hawaiian Islands, tourism is king, and MSO Honolulu is cooperating with industry to bring in a new form of sightseeing - submarine tours. The submersibles present an unusual challenge to Coast Guard inspectors in that their nature presents different requirements for equipment and procedures than surface craft. Some of the unique features that must be inspected are the ballast tanks, through hull connections, and viewports. In addition to inspecting the submarine's structure and equipment, the Coast Guard also examines

the company's operational manual and crew to make sure that the people, crew and passengers are as safe as the vessel they are on. With no existing regulations for inspecting submarines, the Coast Guard personnel, in cooperation with the vessel operators, have adapted the small passenger vessel (or "T-boat") regulations. Navigation and Vessel Inspection Circular 5-93 (Guidance for Certification of Passenger Carrying Submersibles) was developed to provide additional guidance and to document the new procedures.

A Commercial Submarine Emergency Response Workshop was held in November 1995 to bring together members from the Coast Guard, U.S. Navy, the submarine operators, and the local marine salvage community. The meeting allowed all parties to discuss the capabilities of the various organizations, as well as review the design and safety features of the submarines. A dive and safety demonstration was conducted for the participants. Practical drills were conducted. In December 1995 a Search and Rescue Exercise (SAREX) was held off the coast of Oahu. The submarine crews learned how to receive a helicopter basket with the assistance of an HH-65 helicopter from Air Station Barbers Point. Since then these exercises have been held off Maui and the Big Island of Hawaii to great acclaim by Coast Guard members and the submarine operators.

Communication between MSO Honolulu and the commercial submersible companies works both ways with the companies often approaching the Coast Guard with suggestions for operational improvements that can be translated to other areas. The submarine operators and the Coast Guard are working together to break the chain of errors that could lead to an accident.

These and other programs are just the beginning. As the PTP message is spread, the total safety culture is created by concerned individuals in the marine community including Coast Guard personnel, industry leaders, mariners, shoreside workers, vessel owners and operators. By working together, they are bringing the PTP vision to life.

## VISION STATEMENT

To achieve the world's safest, most environmentally sound and cost-effective marine operations by emphasizing the role of people in preventing casualties and pollution.

## GUIDING PRINCIPLES

- *Honor the mariner* - Seek and respect the opinion of those who "do the work," afloat and ashore.
- *Take a quality approach* - Engage all elements of the marine transportation system to drive continuous

improvements.

- *Seek non-regulatory solutions* - Emphasize incentives and innovation while improving basic regulations to maintain a minimum level of safety.
- *Share commitment* - Recognize and act upon the responsibility of government, management and workers to foster a safe and environmentally sound marine transportation system.
- *Manage risk* - Apply cost-effective solutions to marine safety and environmental issues, consistent with our shared public stewardship responsibilities.

## GOALS

- *Know more* - Significantly expand our knowledge and understanding of the human element and its role in maritime operations and accidents.
- *Train more* - Give members of the marine community the necessary skills and knowledge to improve safety and prevent pollution.
- *Do more* - Improve professional performance through a practical application and open communication of human element knowledge within the marine community.
- *Offer more* - Provide incentives for improvement in safety management systems.
- *Cooperate more* - Work together to address the human element in transportation safety and pollution prevention.

*Author: Kriste J. Hall is a technical writer for Soza & Co., Ltd., under contract to the U.S. Coast Guard, Marine Safety & Environmental Protection. Telephone: (202) 267-2997. Jennifer Blain, Soza & Co., Ltd., contributed.*



---

# Simulation Training To Meet Advances in Shipboard Automation

Brian D. Long, STAR Center Director

We all know that the maritime industry does not adapt quickly to new technologies. Gradually, however, the shipboard environment has advanced to include such technologies as Automatic Radar Plotting Aids (ARPA), Electronic Chart Display Information System (ECDIS), Integrated Bridge Systems (IBS), Voyage Management Systems (VMS), joystick controllers, automated Engine and Cargo control rooms. These advancements have been developed in an attempt to increase safety, reduce the workload on the watch officer, and increase the quality of watchkeeping, however, it is important to note that if training is not provided for the operators of this equipment the opposite may result; decreased safety, increased workload, and decreased quality of watchkeeping.

One important phase of this training can be provided at a maritime simulation facility. These facilities provide a controlled environment where students can gradually learn, through a structured curriculum, the capabilities, limitations and operation of specific automation equipment without the obvious risk to the crew, vessel, environment, and passengers, if applicable. The simulators also provide an excellent "test bed" for designers and users to determine how to best utilize a particular piece of equipment or to evaluate between different manufacturers of the same type of equipment.

Recently, the Conference on Maritime Simulation (MARSIM) met in Copenhagen, Denmark, and discussions were held regarding the present status of simulation training and research. This international conference, which is held every three years, attracted over 200 participants from 25 countries. From this conference and subsequent visits to several European simulation facilities, it is evident to me that excellent simulation training and research capabilities exist world-wide and that the current state of simulation technology (hardware, software, courseware) can provide operators and designers of automated shipboard equipment with tremendous benefits. These facilities are constantly adapting their simulators and programs to incorporate new shipboard technologies and to meet new training regulations.

## TRAINING METHOD

Obviously, when introducing a new piece of automated equipment into an existing training program, a training objective must first be clearly defined and then the training program built from that objective. You can not, for example, simply throw an ECDIS on the bridge simulator and continue the training courses as usual. By the way, this principle also applies to the ship itself; a shipping company should not expect to add new automation technology to the vessel without a clear objective of how and when this automation should be utilized.

When addressing training for operation of automated systems, it should be kept in mind that the training requirements for the operators actually increase when automation is introduced. This is due to the fact that the individual needs to be trained in the use of the automation and also needs to be proficient in manual and backup procedures.

We all know the problems which can arise from relying solely on automation. A cruise ship grounding last year involved a failure of the position fixing input to an Integrated Bridge System, which went undetected for numerous hours. Although still under investigation, one can speculate that there may have been a sense of complacency on the bridge since the system had worked flawlessly in the past. This may have led to a relaxing of cross checking procedures with other navigation information.

As we all know from the Prevention Through People (PTP) program the vast majority of maritime casualties are the result of human error. It is important to realize, however, that the human who is responsible for the error is not necessarily the human operating the equipment. In some cases the error can be traced back to the people who designed the equipment or the overall system which incorporates the equipment. The error can even be traced back to the company in some cases for not providing an adequate level of training or not providing guidelines for when and how to use the equipment.

## AVIATION COMPARISON

In the area of maritime training we are constantly looking to the aviation industry for comparisons since it has been quicker to adapt new technologies. In referencing Cockpit Resource Management, which is a compilation of papers on aviation training, some good lessons can be found. For example, in aviation it is interesting to note that initially when automation systems were added to training and check ride sessions, it resulted in an increase in the student failure rate. This was attributed to the fact that the students were not adequately trained on the automated systems before the sessions. This resulted in a revised training evolution which included:

- Generic automation training
- Simulator sessions without automation
- Extensive training on specific automation
- Simulator sessions with the use of automation at the pilots discretion

Several airline companies have adopted an automation philosophy which spells out what the company's stance is on the use of automation. A company may decide to leave it up the operator to

determine in which situations the automation will be best suited and during which time it is better to use a more traditional method.

## JOYSTICK EXAMPLE

As far as the training goes, we need to determine which training device should be used during which stage of the program. If we use the example above, it is best to train an individual on a piece of equipment in a stand alone mode prior to incorporating that system in a much larger system and complex training exercise on a full mission simulator.

As mentioned earlier, maritime simulators can be used to train on specific automated shipboard systems. Since equipment varies significantly from one ship to the other, unlike aviation, this usually involves hardware and software integration to the existing simulator. One example of customized integration to meet customer requirements is the installation of a joystick controller for a cruise company's training program at STAR Center. This controller combines the separate controls of the engines, rudders, and thrusters in a single control device.

*Continued*



*STAR Center's 360° Bridge Simulator equipped with Joystick Controller (inset)*



*To try and imagine how the officers might feel when a new piece of automation is added onboard their vessel, an analogy that almost everyone can identify with follows: Suppose you rent a car and instead of a steering wheel, accelerator, and break pedal, the car is fitted with a joystick which incorporates all of those separate controls. You are told that this makes driving the car much easier and safer. I think you would agree that without training, this device would definitely decrease the safety of the operation. An what could be said about your confidence level in using this device; I think it is safe to say that it would not be very high. If given the choice, I am sure that you would opt to abort the joystick if possible and use the traditional and familiar controls.*

The cruise company saw the tremendous benefit to training their senior officers on this device in a controlled environment; the simulator. To meet this goal, an authentic joystick identical to that which is on board the vessel was integrated into the existing simulator. In conjunction with this, a maneuvering model based on the actual ship maneuvering data was prepared. This allowed a recreation of the entire shipboard environment for the officers participating in the training.

Once the joystick was installed, the validation of the system was conducted. First the ship model was validated separately by one of the captains to insure

that the modeled vessel behaved as the actual ship. Then the joystick was validated by someone with experience with the device as well as the technical representative for the equipment. Also visual and environmental models utilized in the training were validated in a similar manner.

To incorporate this device into our training curriculum, first, lecture modules were presented on the theory and operation of the joystick. Then simple “experiments” were conducted where the students were placed offshore on the simulated vessel to get a feel for how the joystick behaved under various conditions. The exercises were developed so they would



incrementally build to eventually include complex maneuvers in authentic and generic ports under adverse environmental conditions. The training evolution would then culminate in an exercise involving a failure of the system and a review of abort and backup procedures. Throughout the course, extensive maneuvers utilizing traditional controls were also conducted.

From our observations of the training it was obvious that the officers' proficiency on the joystick increased dramatically as the week progressed and from their comments, the students' confidence in using the system had increased significantly. I believe, as do the students who have attended these courses, that this is an ideal use of simulation technology. To realize the benefit of the joystick training example one needs only to consider the alternative; onboard experimentation in a real port with a ship full of passengers. I think everyone would agree that this is not the time to try a radically different maneuvering device.

## SUMMARY

The joystick is just one example of the right way to introduce a new piece of shipboard automation but this philosophy can translate to other equipment such

as ECDIS, IBS, portable Vessel Traffic Systems (VTS), etc. Any of this equipment can be integrated into a simulator so that it may be evaluated or used for training in a controlled environment. Other centers world wide have also integrated joysticks, ECDIS units, voyage management systems (VMS), as well as other specific equipment to conduct research or to meet specific customer requirements with similar results.

Shipping companies must keep in mind that if the people are not trained properly on these automated systems, the majority of them will simply not use the equipment, or even worse, misuse it. This could lead to "automation assisted" casualties as was seen with the introduction of RADAR and ARPA. With adequate structured training programs, however, these automated systems can achieve the desired results of increased safety, reduced workload, and an improved quality of watchkeeping.

Brian D. Long is the Director of RTM STAR Center, a Simulation Training and Research organization with locations in Dania, Florida and Toledo, Ohio. Mr. Long has worked in the simulation field in various capacities since 1984. Mr. Long is a graduate of SUNY Maritime College and holds an engineering degree and an unlimited mates license.





## PC-Based Radar Simulators in Coast Guard Approved Courses

Innovative technology has provided a variety of useful tools for the mariner; thereby, making the task of safe navigation much less burdensome. Radio, Radar, and D-GPS are potentially tremendous assets in any pilothouse or ship's bridge.

Unfortunately, simple installation of such equipment does not make vessels any safer to operate. Numerous reviews of marine accident reports suggest that mere installation of equipment is just not enough. However, timely application of knowledge and skills in the proper use of these navigational aids is essential. This was certainly a key factor in the most deadly marine incident on U.S. waters in recent memory.

Well past midnight, on September 22, 1993, a radar-equipped towboat pushing several barges was not where its operator believed it was. The MAUVILLA was lost in the blanketing fog of Big Bayou Canot and headed for the tragic consequences of a chain of events beginning with the allision of a railroad bridge. This incident became the driving force in changes to regulations designed to prevent a repeat of circumstances surrounding the fatal disaster.

More than a decade ago, technology—in the form of marine-radar simulators—was identified as essential to improve marine safety through training, testing, and certifying mariners' competency in radar observation and plotting. Back then the emphasis was on collision avoidance, and the training requirements were directed primarily at masters and mates on vessels of at least 200 gross tons. Radar Schools offered courses based on the MARAD model, as this was the standard adopted by the USCG. Computers running simulation programs provided inputs to actual radar units and displays. Since the implementation of revised regulations as noted above, the scope of Coast Guard approved radar training courses has broadened to also emphasize position determination. Advisory Committee members, public comments, and marine educators provided information useful in the

development of NVIC 9-94, the current guidelines for USCG approved radar-observer training courses.

To have radar courses approved today, or to have them remain approved, radar schools must show their curricula complies with the new standards. In addition to dealing with multiple targets (vessels) in collision avoidance, this means incorporating learning objectives on position determination, and using radar simulators with land-masses, coastline, or riverbanks that the students may observe and/or measure. Schools without the requisite simulator capability began searching for upgrades and alternatives. In an effort to keep their costs down, several schools have chosen desk-top, PC-based radar simulation to conduct the required practice and demonstrations of skills. While earlier attempts to offer radar training on desktop devices were unsatisfactory or marginal, this option is now viable due to the significant leaps in power and capability of hardware, as well as the development of software generating the visual elements needed to accomplish the training and testing. Factors leading to the Coast Guard's acceptance of PC-based radar simulators include:

1. A survey of currently available marine-radar units. Reflection plotters appear to have been largely phased-out. They are certainly obsolete for units with ARPA capabilities, or redundant where electronic marking features are used. Consequently, mandating exercises or demonstrations of proficiency in this type of "scope" plotting would be, at best, questionable;

2. The ability of today's PC hardware and software to effectively emulate key marine-radar functions and performance; and,

3. The need to emphasize the focus on developing and demonstrating watchkeeping skills which will positively reduce the likelihood of mishaps, and thereby improve safety.

In addition, the typical deck-license candidate seeking a radar-observer endorsement must have at

least two years of underway experience. In that time, he or she should have gained some familiarity with the radar units installed on their vessels. Further, many of today's license applicants may in fact have experience with PCs on the job and/or in education and training environments. The Coast Guard expects mariners will find that PC-based radar-simulators used in approved courses will improve their ability to use the particular radar-units installed on their vessels in determining risk of collision, avoiding collisions and allisions, and monitoring own-ship's position.

Future training in ARPA, GMDSS, and the use of other navigational safety devices may be delivered using PC-based simulators. While

validation of simulator-based training has largely relied on manufacturers, schools, and/or Coast Guard personnel, in order to conform with the 1995 amendments to the STCW Convention, it is expected standard-setting organizations will be involved in establishing a more structured process for validating simulators used in future approved courses to come.

A key element in all simulator-based courses must be the danger of over-reliance on radar, ARPA, and the other tools technology delivers; for the importance of non-technical and "low-tech" watchkeeping skills remain as important as ever, and must be understood and practiced.



---

# NAUTICAL QUERIES

---

## DECK

1. Fusible-link fire dampers are operated by \_\_\_\_\_.
  - A. a mechanical arm outside the vent duct
  - B. electrical controls on the bridge
  - C. the heat of a fire melting the link
  - D. a break-glass and pull-cable system
2. A sextant having an index error that is "off the arc" has a \_\_\_\_\_.
  - A. positive correction
  - B. dip error
  - C. negative correction
  - D. semidiameter error
3. What is the effect of heated intake air on a diesel engine?
  - A. Increases efficiency
  - B. Increases engine horsepower
  - C. Increases engine life
  - D. Reduces engine horsepower
4. The great circle on the celestial sphere that passes through the zenith and the north and south poles is the \_\_\_\_\_.
  - A. hour circle
  - B. prime vertical
  - C. principal vertical
  - D. ecliptic
5. How should you signal the crane operator to stop?
  - A. Place both fists in front of your body with the thumbs pointing outward.
  - B. Extend both arms out with the palms down and move arms back and forth.
  - C. Extend arm with the palm down and hold this position rigidly.
  - D. Clasp hands in front of your body.
6. Which statement is correct concerning the carriage of coal in bulk?
  - A. Coal should be vented with surface ventilation only.
  - B. Because of its inherent vice, coal should not be loaded wet.
  - C. Dunnage should be placed against ship's sides and around stanchions.
  - D. Through ventilation, as well as surface ventilation, should be provided whenever possible.
7. The dividing meridian between zone descriptions - 4 and -5 is \_\_\_\_\_.
  - A. 60°00'E
  - B. 67°30'E
  - C. 75°00'E
  - D. 60°00'W
8. When towing another vessel astern, the length of the towline should be \_\_\_\_\_.
  - A. as long as possible
  - B. such that one vessel will be on crest while the other is in a trough
  - C. such that the vessel will be "in step"
  - D. not over two wave lengths in seas up to 10 feet
9. While providing assistance to a victim of an epileptic seizure, it is most important to \_\_\_\_\_.
  - A. give artificial respiration
  - B. prevent patient from hurting himself
  - C. keep the patient awake and make him/her walk if necessary to keep him/his awake
  - D. remove any soiled clothing and put the patient in a clean bed
10. Considering manning requirements for US flag vessels, your 2 watch cargo vessel has a deck crew of 20 people, exclusive of officers. How many of these people do the manning regulations require to be able seamen?
  - A. 13
  - B. 10
  - C. 7
  - D. 5

---

## DECK ANSWERS

**1-C, 2-A, 3-D, 4-C, 5-C, 6-A, 7-B, 8-C, 9-B, 10-B** *If you have any questions concerning this quiz, please contact the National Maritime Center at (703) 235-1368.*

---

---

## ENGINEERING

1. The auxiliary exhaust system is typically supplied by steam directly from \_\_\_\_\_.
  - A. the main engine
  - B. turbine and reciprocating pumps
  - C. Spring bearings
  - D. all of the above
2. When completing the ballasting operation of a contaminated tank, which of the following problems must be guarded against?
  - A. Back flow of contaminated water
  - B. Loss of pump suction
  - C. Excessive tank pressure due to closed vents
  - D. Motor overload due to high discharge head
3. If an oil fire occurs in the double casing of a stemming boiler, you should \_\_\_\_\_.
  - A. increase the forced draft fan speed
  - B. secure the feedwater supply to the boiler
  - C. secure the fuel oil supply to the burners
  - D. apply water with a smooth bore nozzle
4. Excessive exhaust temperatures in a two-stroke/cycle diesel engine can be caused by a/an \_\_\_\_\_.
  - A. high injection pressure
  - B. high firing pressure
  - C. overheated air starting line
  - D. carbon build up in the exhaust ports
5. Which statement is true concerning a split-phase induction motor?
  - A. Motor rotation can be reversed without changing the windings or leads.
  - B. Motor speed can be readily adjusted from zero to full speed.
  - C. The motor will run as a generator with the proper wiring.
  - D. Motor rotation can be reversed by reversing the leads on the starting winding.
6. Which of the listed fire extinguishers would be most effective to use on a fire in a small electric motor?
  - A. Soda acid
  - B. Foam
  - C. CO<sub>2</sub>
  - D. Light water
7. Boiler efficiency and its ability to absorb heat is limited by the need to \_\_\_\_\_.
  - A. maintain an excess of CO during transient firing rates
  - B. prevent excess air density at low load conditions
  - C. protect the safety valves from excessive temperature
  - D. maintain uptake gas temperature above the dew point
8. The cooling water flow from an air ejector intercondenser and aftercondenser is discharged directly into the \_\_\_\_\_.
  - A. main condenser hotwell
  - B. auxiliary condenser hotwell
  - C. condensate and feed system
  - D. atmospheric drain tank
9. When hydrogen sulfide has been encountered on a MODU, or is anticipated, monitoring devices must sound an alarm (differing from the lower concentration alarm) or otherwise warn employees when the concentration of the gas reaches or exceeds how many parts per million?
  - A. 20
  - B. 50
  - C. 100
  - D. 200
10. Mechanical foam used for firefighting, is produced by \_\_\_\_\_.

A mechanically mixing and agitating foam chemical, water, and air

  - B. a chemical reaction of foam components and air
  - C. gas bubbles liberated when the foam chemical contacts fire
  - D. chemical reaction of foam components and water

---

## ENGINEERING ANSWERS

**1-B, 2-A, 3-C, 4-D, 5-D, 6-C, 7-D, 8-C, 9-B, 10-A** *If you have any questions concerning this quiz, please contact the National Maritime Center at (703) 235-1368.*

---

# INVESTIGATOR'S CORNER

## SAVING SECONDS

by Tim Farley

It's a clear, calm sunny day, not a cloud in the sky. You've just cleaned the pool, the water's clean and clear and it's time to grab a cool one. Life is oh ... so good. As you meander back from the fridge you gasp as you catch a glimpse of what looks like your two year old face down and floating in the pool. Your heart drops to the deck, you become flush and fired up all at once, tunnel vision sets in focusing on the only thing that matters; getting to your baby. You drop your drink, heave your body into action blind to the fact you just stepped barefoot on your shattered glass, hurdle the lawn chairs and launch yourself into the water convinced that this is not really happening.

The Chief mate aboard the foreign chemical tanker M/V CHEMBULK SINGAPORE might have felt similarly one beautiful September day in Texas City, Texas. The Mate was on deck overseeing the routine bulk loading operations of Polybutene cargo, a water white combustible/flammable liquid. This cargo was described as benign in appearance, producing no fumes or foul odors. Because of this cargo's volatility and sensitivity to water contamination, the ship's cargo tank receiving it had been thoroughly purged of oxygen with nitrogen, a colorless, odorless inert gas. The oxygen content of the cargo tank was tested prior to loading and found to be two percent.

As the loading operations progressed the Chief Mate suddenly signaled the dock for an emergency shutdown of the transfer procedures and disappeared from sight. Once operations were secured a cargo inspector boarded the vessel to investigate the unexpected stoppage and found the cargo deck completely abandoned. Finally, after rustling out a member of the crew the inspector was informed that two crewmembers were missing, one of which was the Chief Mate. A search of the ship was initiated and the two missing crewmembers were found floating face down in the Polybutene cargo tank.

The investigation into the events that led up to this tragedy revealed that, apparently, a crewman had been stationed near the open cargo tank top in order to monitor the progress of the loading operations. As the loading

progressed the nitrogen atmosphere in the tank was displaced, somehow overcoming the crewman who subsequently fell into the tank through the open tank top.

The Chief Mate, having either noticed the crewman missing or having actually seen him fall into the cargo tank, immediately ordered an emergency shutdown of the cargo operations and rushed to the scene. Whether the Chief Mate entered the tank directly or placed his head into the cargo tank trunk to get a better view of the crewman, we can only speculate. However, the Mate was also overcome by the nitrogen gas and fell into the cargo tank with tragic results.

Many questions are called to mind when looking at this incident. Was the crewman attending the tank fully aware of the hazards involved with loading this cargo? Did he understand that the tank was devoid of oxygen, and the cargo tank had been thoroughly purged with nitrogen, a colorless, odorless gas? Did he understand that, as the tank was filled with product, the atmosphere in the tank would pour out of the tank top?

Why was the crewman overcome? Why was he even near the cargo tank top. Did he put his head in the tank to get a good gauge of the cargo ullage? What was he actually instructed to do? What were his duties? Why wasn't the automatic tank gauging system used? Sufficient precautions were taken to place a barrier between the cargo and any water vapor or ignition source that might be found. Tragically, no consideration was given to the personnel hazards.

Code of Federal Regulation 46, at Section 35.30-10 allows cargo tank 'hatches (tank tops), ullage holes, or Butterworth plates to be open without flame screens fitted as long as the operation is under the supervision of the senior members of the crew or if the opened tank is gas free. Clearly, the open tank top in this case was permitted under the current rules. However, were personnel protected from falling into the tank as is the intent of 46 CFR Section 32.02-15 - Guards at Dangerous Places? This section requires all exposed and dangerous places be properly protected with covers, guards, or rails in order that the danger of accidents may be minimized. If a person can fall into a cargo tank shouldn't the area around the tank top have been secured?

How often do we see cases where someone, rushing to the aid of another, also becomes a victim thus exacerbating the situation. Why does this happen? How could the Chief Mate not be fully aware of the hazards of entering this cargo tank? He would have been intimately

familiar with the hazardous atmosphere within the tank as he would have overseen the nitrogen gas purge and the removal of all the oxygen in the tank. Most certainly the Chief Mate experienced an overwhelming need to help, to actively do something for his fallen crewman. Amplify this by a scene described by the investigator's on scene as almost surreal, tranquil, and very benign. There were no apparent indications of danger; no fumes or foul odors. The water-like cargo itself shimmered with a transparent, almost Caribbean blue hue given off by the cargo tank coating. Overcome by events, one can easily understand why the Chief Mate, the Officer on board most responsible for the deck crew and who is accustomed to "getting things done", may have momentarily overlooked the grave nature of the situation and peeked his head into the tank. Unfortunately, this brief lapse of attention may have caused his death.

Certainly, the Chief Mate was one of the best suited crewmembers to understand the hazardous nature of the situation he was in. The question begs, how do we prevent this from happening again? Should tank top's always be fully secured and the atmosphere only released through the vent system? Although preferred, this solution is not always practical. However, had this been the case the final outcome may have been quite different. Someone may still have been overcome by the nitrogen gas (or lack of oxygen) but the chance they would have fallen into the cargo tank itself would have been eliminated. Further, had some type of rail or other physical barrier existed to keep personnel away from the edge of the tank top, it would be quite unlikely this accident would have happened as it did.

A conspicuous sign or signal in close proximity to the hazardous area also might have allowed the Chief Mate just a brief reminder that the cargo tank contained a dangerous, oxygen deficient atmosphere. This might have helped him to take a brief moment to reassess the situation and could have minimized the tragic results of this accident. When the Mate saw one of his crew in distress he acted instinctively to help—went on 'autopilot' so to say. One of his crew, his shipmate, his ward was in trouble and he most likely immediately reacted to the situation without any thought for his safety. Added to the sense of urgency was the fact that the scene was tranquil and had a benign appearance. Had a clear indication of the danger been present, the Chief Mate's memory may have been jogged. This might have him a brief moment to get control of his reactions and respond more appropriately.

The Coast Guard investigating officer who responded to this accident also relayed the following regarding the shoreside rescue team that responded to the incident. Apparently, the rescue team appeared to be ill prepared, not very well trained to handle this type of

situation, and were in poor physical condition. They had no apparent awareness of the hazards they were dealing with. They mounted a rescue effort when there was absolutely no hope for rescue. The crewmembers were floating face down in Polybutene in an atmosphere of less than 2% oxygen. The response to this accident was mounted well after any reasonable rescue could be expected. The concentration of the effort should have been the retrieval of the bodies. This would have considerably reduced the unnecessary risk to each of the rescuers.

As it was, the rescuer's hastily responded with ill fitting equipment. The bodies were eventually retrieved but two squad members subsequently collapsed—one on deck, another on the gangway while exiting the vessel. One rescuer actually went for a dip in the product without actually knowing the hazards associated with it.

Exactly twelve days after this accident a similar tragedy occurred near Philadelphia, PA on board the foreign flag bulk carrier, M/V SAGA WAVE. During discharge operations of cut timber, an alarm was raised that a body had been found lying-in the after access trunk of the #8 cargo hold. As the crew mustered to mount a rescue attempt, the Chief Mate arrived obscure and immediately attempted a rescue on his own. By the time the rescue party arrived two bodies were observed in the space. A longshoreman and the Chief Mate were later removed from the space, transported to the hospital, and pronounced dead due to hypoxia caused by exposure to an oxygen deficient atmosphere.

Air samples of the cargo spaces and access trunks revealed that the atmosphere in the opened #8 cargo hold was normal but the after access trunk where the victim's were found contained 14% oxygen as well as an elevated level of carbon monoxide. Similarly, the after access trunk to the #10 cargo hold contained 10% oxygen and a high concentration of carbon monoxide. The cargo contained in holds #8 and #10 was the same and both cargo holds had been loaded and sealed five weeks earlier in Vancouver, British Columbia.

Although the cause of the oxygen deficient atmosphere in the access trunks cannot be conclusively determined, it was theorized that a fungicide treatment the timber received during its cultivation sped the natural decay of the wood. Further, this intensified natural reaction when combined with the five week transit through a moist/humid environment (Panama Canal) and the lack of any ventilation, allowed for the depletion of the oxygen supply in the sealed cargo hold and adjacent access trunks.

Since the cargo holds themselves contained little oxygen due to the load configuration, it was felt that the oxygen used for the reaction most likely originated in the

access trunks. These trunks provide cargo hold entry and are separated from the cargo spaces by non airtight doors. The particular access trunks with deficient levels of oxygen were located on the aft end of the cargo holds and, unlike the forward access trunks that have several doors and permit entry to each deck in the cargo hold, the aft access trunks only permitted access to the lower hold area.

Although these two incidents occurred under different circumstances they both illustrate the hazards of working in and around oxygen deficient atmospheres. More importantly, they demonstrate the tremendous risks of responding to a confined space entry accident without taking the opportunity to fully assess the situation at hand in each case a knowledgeable, experienced individual rushed to the aid of another in distress and was caught up in the situation—a natural reaction.

Unfortunately, their response put them at great risk.

Had each of the Chief Mate's involved here been able to take a moment to think the situation through, the outcomes of these accidents, although still tragic, may not have been so severe. Although every second counts when responding to a confined space accident, taking several of them for yourself may ultimately save you a lifetime.

Tim Farley  
USCG(3 Licensed Master, Any Gross Tons, Oceans  
Works as a Safety Specialist in the Investigations and  
Office, Marine Safety and Environmental Protection -  
*Commandant (G-MOA)*

Captain Farley has sailed deep sea  
Board Oil and Chemical Tankers





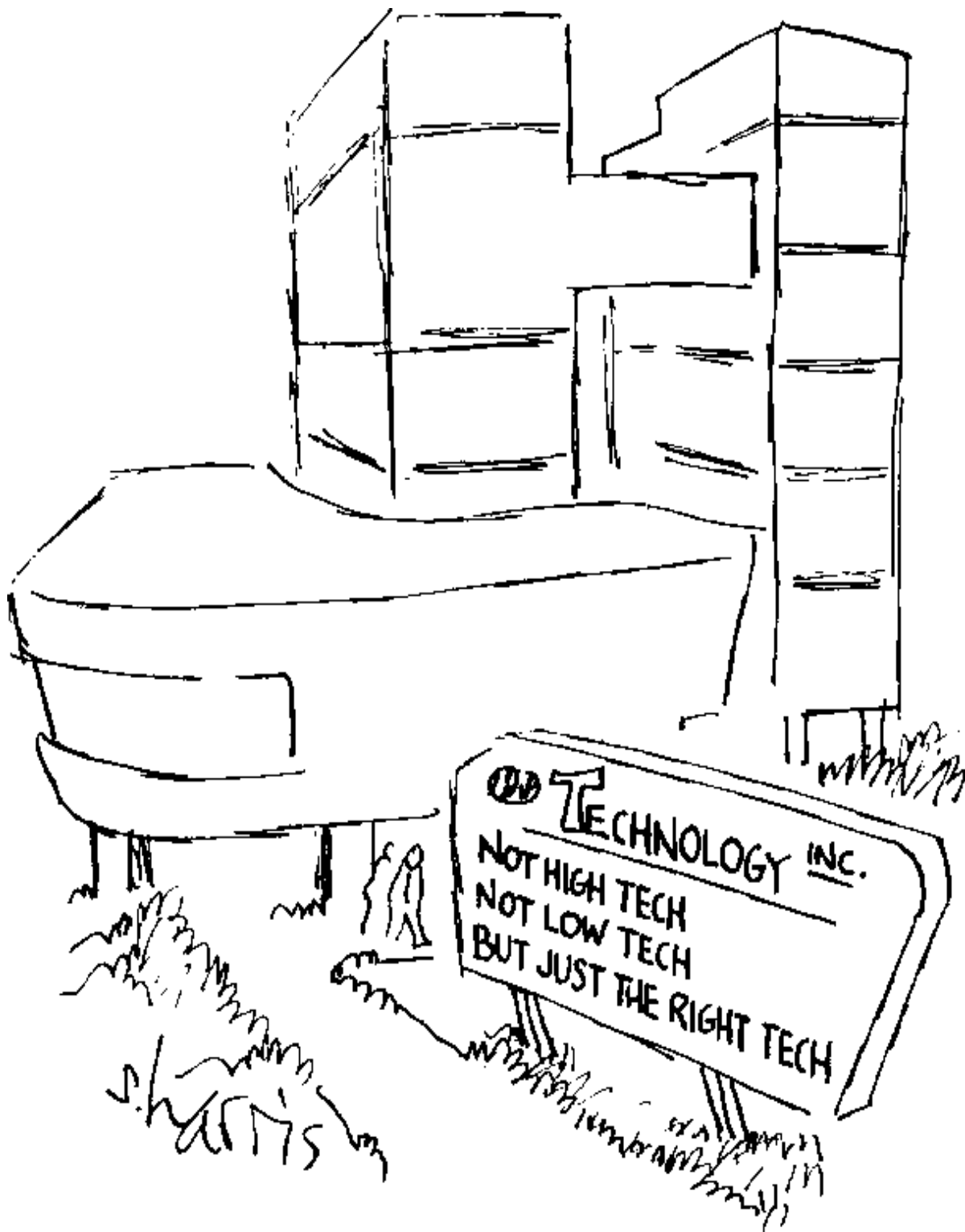

Reprint permission thanks to Sidney Harris.  
U.S. Government Printing Office 1996-405-533/20004

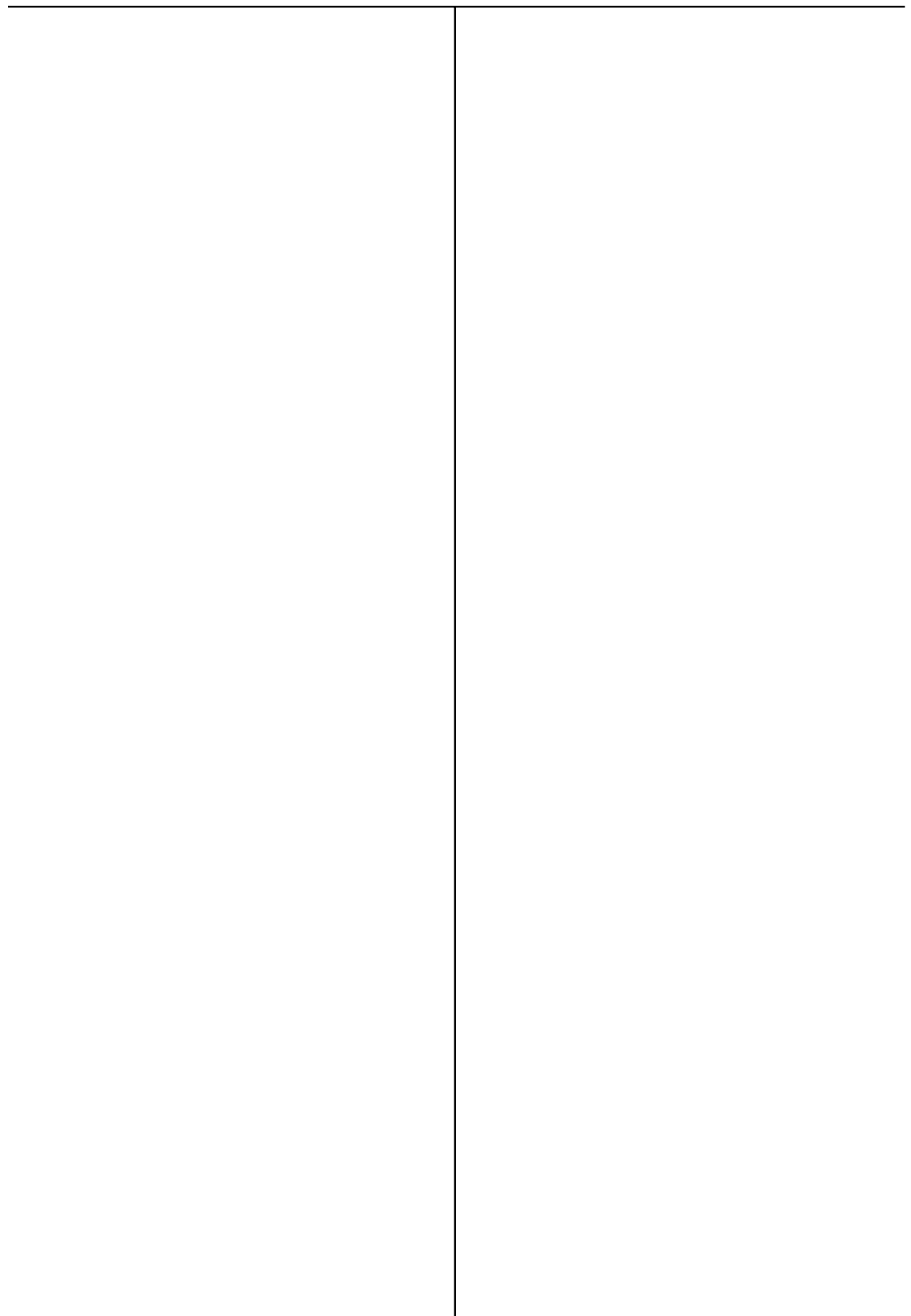

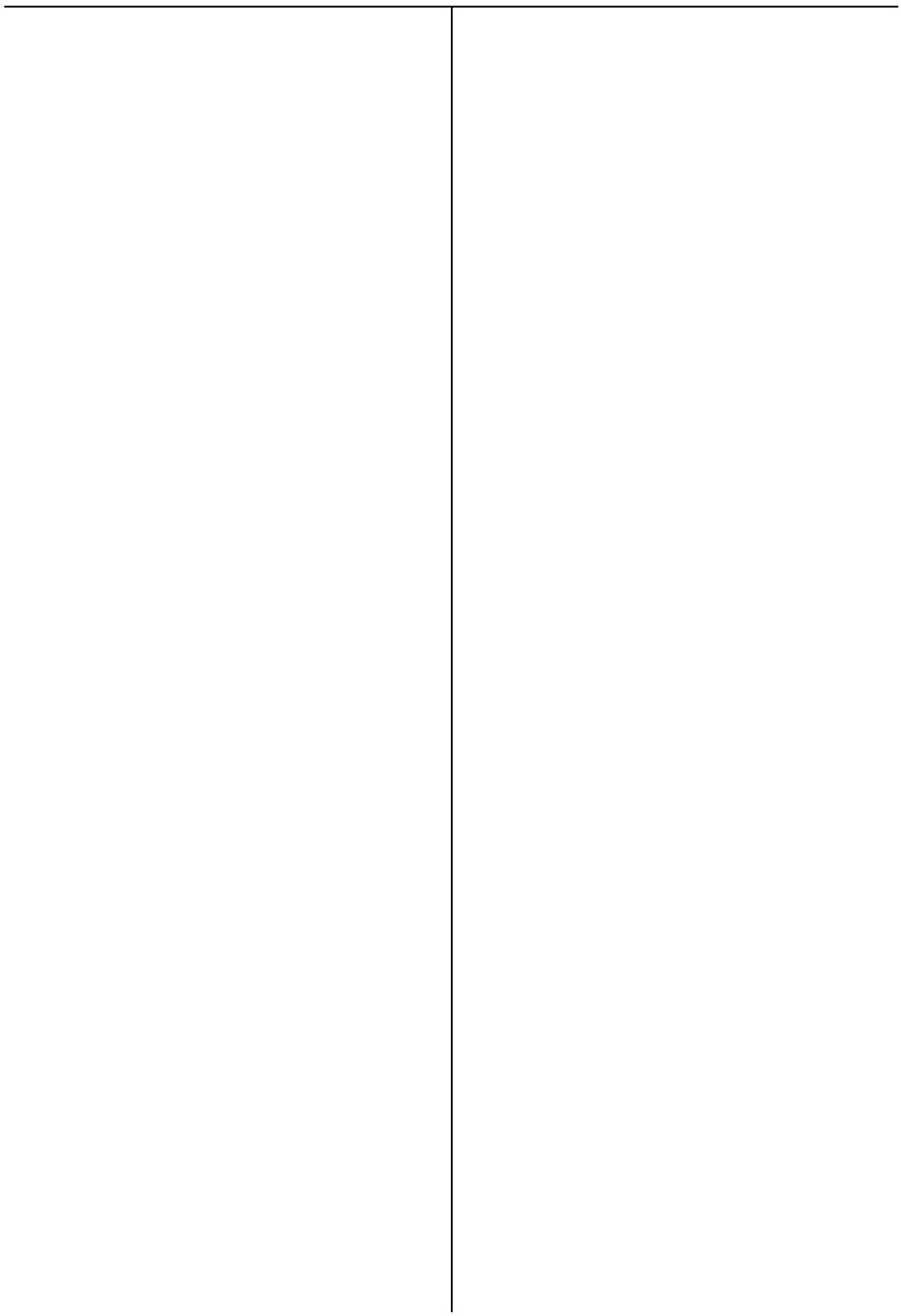

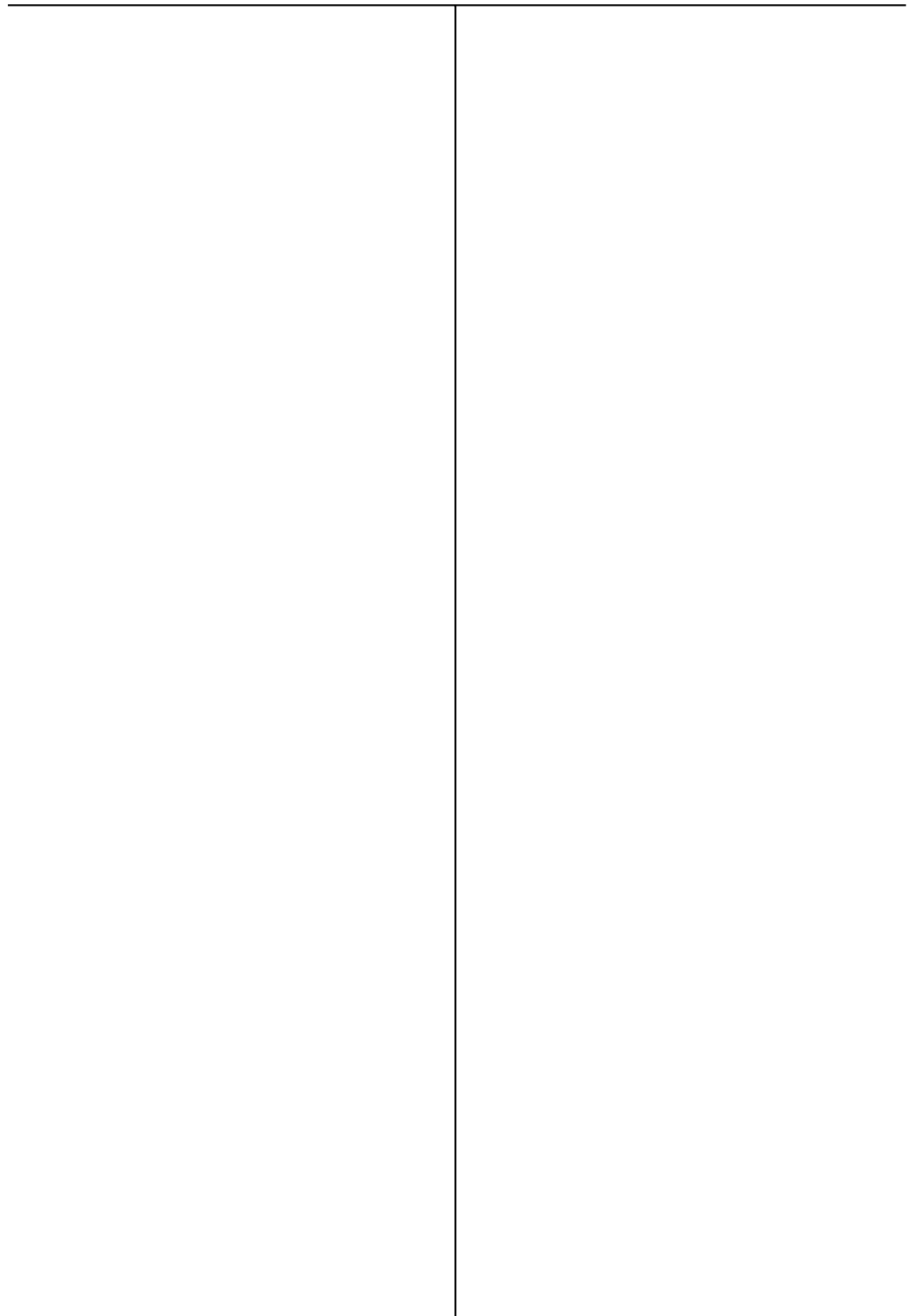

Marine Safety Council

# PROCEEDINGS

U.S. Department  
of Transportation

United States  
Coast Guard



The Coast Guard Journal of Safety at Sea

July-September 1996

Volume 53, Number 3

How Technology is Affecting  
the Maritime World

---

*Front cover photo:*  
???

*Back cover photo:*  
???



U.S. Department  
of Transportation

**United States  
Coast Guard**

National Maritime Center  
4200 Wilson Blvd., Suite 510  
Arlington, VA 22203-1804

Official Business  
Penalty for Private Use \$300