



Commanding Officer
United States Coast Guard

2100 2nd Street SW
Washington, DC 20593
Staff Symbol: G-MOC
Phone: (202) 267-2978

COMDTPUB P16700.4
NVIC 1-01

11 DECEMBER
2000

NAVIGATION AND VESSEL INSPECTION CIRCULAR NO. 1-01

Subj: INSPECTION OF AMPHIBIOUS PASSENGER CARRYING VEHICLES

1. PURPOSE. This Circular provides supplemental guidance for the certification of passenger carrying amphibious vehicles under Title 46, Code of Federal Regulations, Subchapter T - Small Passenger Vessels (under 100 gross tons) (46 CFR Parts 175-187).
2. ACTION.
 - a. Officers in Charge, Marine Inspection (OCMI) should ensure that Coast Guard plan review, inspection, and certification of amphibious vehicles is based on the guidance contained in this circular. It is recommended that new or unusual designs, modifications and or other alterations to amphibious vehicles be forwarded from OCMI's via their chain of command to the Coast Guard Office of Compliance (G-MOC), Office of Design and Engineering Standards (G-MSE) or Marine Safety Center (MSC) as appropriate. Owners, operators, designers and builders of passenger carrying amphibians must become familiar with the applicable regulations and standards. To facilitate a timely inspection for certification, they are also urged to closely follow the guidelines of enclosure (1). OCMI's should encourage operators of non-inspected amphibious vehicles to also follow these guidelines.
 - b. The Coast Guard recognizes that changes may be needed to existing amphibious vehicles. OCMI's should carefully review the contents of this guidance at each inspection for certification or reinspection and agree upon a satisfactory implementation plan and timeline to modify existing amphibians, as necessary, bearing in mind local risks and the safety of passengers.
3. DIRECTIVES AFFECTED. Marine Safety Manual, Volume II, Material Inspection, COMDTINST M16000.7 (Series), Section B, Chapter 4.R.3. is superseded.

4. BACKGROUND.

- a. The three main types of vehicles used in the amphibious industry today were originally designed as military transports and are known as DUKWs (D = 1942; U = Utility; K = Front Wheel Drive; and W = Two rear driving axles), LARCs (Lighter, Amphibious, Resupply, Cargo), and ALVIS STALWARTs. DUKW's were originally manufactured in the early 40's (for the U.S. Army), while LARCs (for the U.S. Navy) and ALVIS STALWARTs (for the British Army) originally manufactured in the late 60's.
- b. Congress directed the regulation of vessels in accordance with their intended service. The service categories requiring Coast Guard inspection are found in Title 46, United States Code (USC) § 3301. Amphibious passenger carrying vehicles meet the definition of a small passenger vessel in Title 46, USC § 2101 (35) and are required to undergo inspection by Title 46, USC § 3301(8). Congress established the service category of small passenger vessel, without regard to construction medium or propulsion method. Amphibious vehicles are regulated under Title 46, Code of Federal Regulations (CFR), Subchapter T which takes into consideration the method of construction, outfitting of lifesaving and fire protection equipment, machinery and electrical installations, and operational requirements.

5. DISCUSSION.

- a. On May 1, 1999, the Coast Guard inspected small passenger vessel MISS MAJESTIC (a "DUKW" amphibious vehicle) rapidly sank in 60 feet of water about 250 yards from shore in Lake Hamilton, near Hot Springs, Arkansas. Flooding of the vehicle was not apparent to those on board before downflooding over the stern became imminent. The vehicle sank in less than 30 seconds after the master recognized the vehicle was in distress. The vehicle's master and seven of the twenty passengers escaped from the vehicle after it sank and made it to the surface alive. Thirteen of the twenty passengers drowned. A Marine Board of Investigation determined the cause of the casualty to be "unchecked flooding ... resulting from the aft shaft boot seal dislodging from the shaft housing at the start of waterborne operation."
- b. One of the recommendations from the Marine Board of Investigation report was for the Coast Guard and the amphibious passenger vehicle industry to meet and develop comprehensive guidelines containing best practices on the inspection and operation of these vehicles. In February 2000, G-MOC sponsored a two-day meeting between owners/operators of DUKW vehicles, industry experts and Coast Guard personnel. This meeting yielded open and frank discussions on the regulation, inspection and operation of these vehicles. The information gleaned from this meeting created the foundation upon which the enclosed guidance was formed.
- c. The regulations covering small passenger vessels are unique in that they grant the OCMI considerable latitude and authority to accept alternate arrangements to those specified in regulation, if an equivalency can be demonstrated. This provision was specifically placed in the regulations to account for the vast differences in the types of vehicles classified as

small passenger vessels; which include submersibles, amphibians, excursion vessels, water taxis, dinner cruise vessels and ferries to name a few. Upon survey and review of national and local guidance for the inspection and certification of DUKWs, it was determined that a national guideline was needed to ensure that the major safety systems aboard these vehicles are reviewed and inspected consistently in all regions.

- d. This circular is intended to outline a basis for determining the equivalency of passenger carrying amphibious vehicles to conventional small passenger vessels. Since the applicable regulations were developed primarily with traditional vessels in mind, many specific regulations cannot be readily applied to, or may otherwise be inappropriate for, an amphibious vehicle. The Coast Guard's approach to the unique design and operational hazards of amphibious vehicles is to require a level of safety equivalent to that required for a vessel of similar size and service. This is established in part through a combination of design requirements and operational restrictions. Additionally, risk management is incorporated in the enclosed guidance by considering the entire vehicle and its equipment as a complete safety system.



R. C. NORTH
Assistant Commandant for Marine Safety
and Environmental Protection

Encl: (1) Guidelines for the Certification of "DUKW" Amphibious Vehicles

GUIDELINES
FOR THE
CERTIFICATION OF
“DUKW”
AMPHIBIOUS
VEHICLES

(Page intentionally left blank)

CONTENTS

	Page
I. PURPOSE	5
II. GENERAL	7
A. Military DUKWs	7
B. Unique Design Features	8
C. Commercial Passenger Carrying DUKWs	11
D. Lessons Learned from the MISS MAJESTIC Casualty	12
III. REFERENCES	14
A. Code of Federal Regulations	14
B. Navigation and Vessel Inspection Circular	14
C. American Boat and Yacht Council	14
D. War Department Technical Manual	14
IV. GUIDELINES FOR CERTIFICATION	15
A. General Provisions	15
B. Inspection and Certification	15
C. Construction and Arrangement	18
D. Intact Stability and Seaworthiness	21
E. Subdivision, Damage Stability, and Watertight Integrity	22
F. Lifesaving Equipment and Arrangements	24
G. Fire Protection Equipment	24
H. Machinery Installation	26
I. Electrical Installation	31
J. Vehicle Control and Miscellaneous Systems and Equipment	32
K. Operations	32
L. Sample COI Endorsements	36

(Page intentionally left blank)

I. PURPOSE

This guide is intended to disseminate to Coast Guard marine inspectors, vehicle owners/operators, and repair facilities information relating to good marine practice in the inspection, operation and repair of amphibious vehicles. This information is furnished for guidance purposes. Nothing herein shall be taken as amending applicable regulations, or as prescribing or limiting the authority and responsibility of the Officer in Charge, Marine Inspection (OCMI) in the exercise of good judgment.

These guidelines are intended to summarize, in a general way, technical data and background information pertaining to the design, inspection and operation of amphibious vehicles. They are not intended to specify the degree of thoroughness of any inspection, which of course, must be left to the inspector. Nor are they designed to be a substitute for the exercise of good judgment in the solution of any particular problems. They are intended to serve the following purposes:

- Summarize and consolidate technical information pertaining to the design and inspection of amphibious DUKW vehicles.
- Promote uniformity in the approach to certification requirements among the various marine inspection offices.
- Consolidate best practices currently being used in the industry.

Further these guidelines will explore the following methodology to be used to certificate DUKWs:

- The certification of DUKWs should be through a systems approach.
- The complete vehicle must be considered as providing an equivalent level of safety to other vessels certificated under Title 46, Code of Federal Regulations (CFR), Subchapter T.
- When a design requirement cannot be met, equivalencies and or operational controls should be considered.

(Page intentionally left blank)

II. GENERAL

- A. Military DUKWs: (D = 1942; U = Utility; K = Front Wheel Drive; and W = Two rear driving axles) are vintage World War II amphibious all wheel drive vehicles. They were designed for the purpose of making beach landings and then proceeding onshore to provide limited troop transportation away from the beachhead. These vehicles were built with a life expectancy of only a few months. Although mechanically rugged, hull construction was simplified for the sake of the accelerated production schedule and the vehicle's anticipated short life expectancy. Of the approximately 21,200+ made, only the few units not transported overseas remain in the United States. DUKWs in their military configuration were based on a 2-½ ton 6x6 truck chassis with an overall hull length of 31 feet. It was equipped with a GMC 270 cubic inch 6 cylinder gasoline engine. It had a 5-speed transmission with a 2-speed transfer case. The vehicle could carry a payload of 5,000 lbs. at 50 mph on land and just over 5 knots on the water.

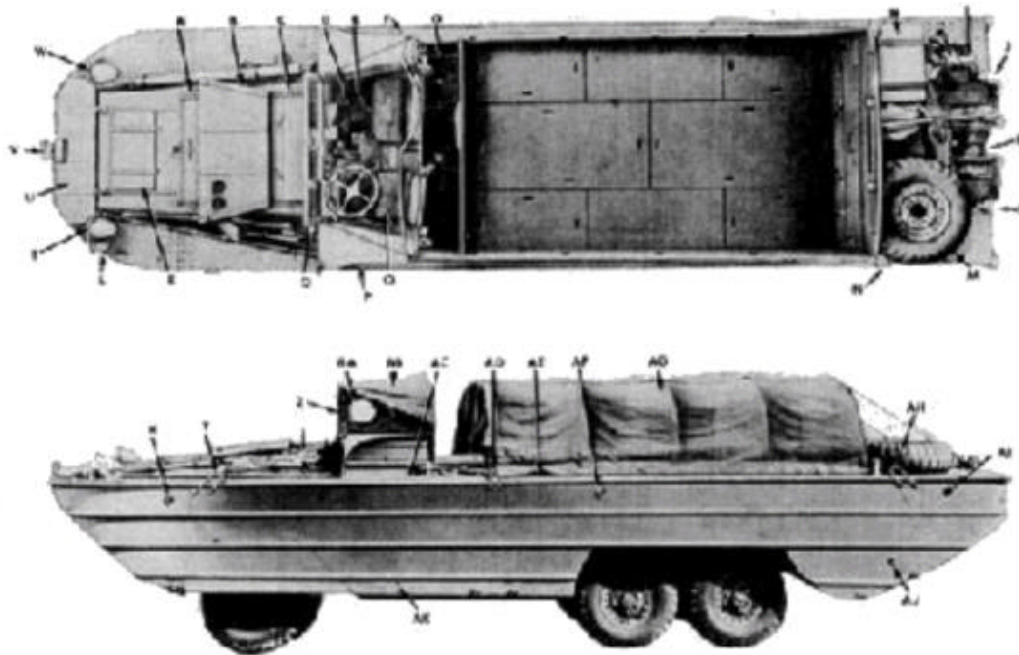

(DUKW in military configuration)

B. Unique Design Features: The following diagrams are taken from the War Technical Manuals and graphically show the design of these vehicles. The uniqueness of the DUKW is seen in the marriage of the truck chassis with power train to the hull. The hull design had to take into consideration the flexibility of the truck chassis and the movement of the drive train through the hull penetrations while still maintaining watertight and structural integrity. A study of the following diagrams is helpful in understanding the interaction between the chassis and hull.

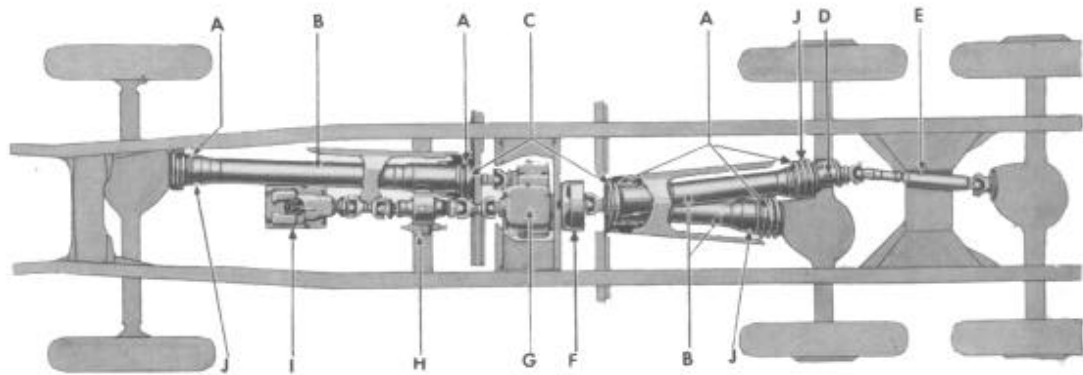

- | | |
|-----------------------------|----------------------------------|
| A. Shaft Housing Seal | F. Hand Brake |
| B. Shaft Housing | G. Main Transfer Case |
| C. Hull Bulkheads | H. Water Propeller Transfer Case |
| D. Pillow Block | I. Transmission |
| E. Shaft Assembly | J. Housing Drain Plugs |
| 1. Shaft Linkage | 5. Strut |
| 2. Forward Bearing Assembly | 6. Journal & Bearing Assembly |
| 3. Thrust Bearing Assembly | 7. Water Propeller |
| 4. Stuffing Box | |

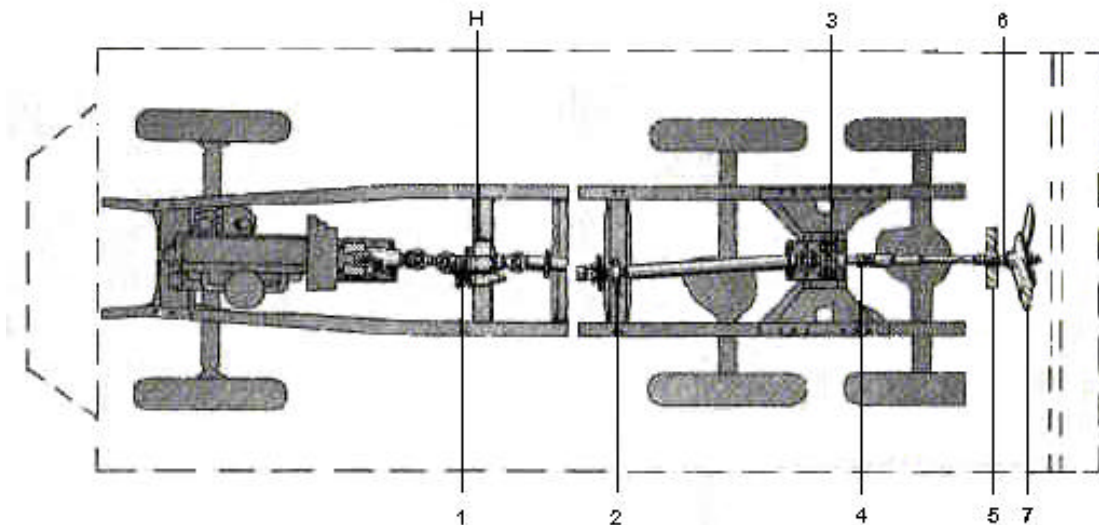

envelope of the hull, which terminates at the differential. It is bolted to the hull by the Seal Retaining Ring and the Housing Seal. It is connected to the differential by the Housing Seal and Seal Clamp Rings. The Shaft Housing is supported and held in position, relative to the hull, by the hinge assembly and relative to the differential by the internal support bracket. The housing seals provide the needed flexibility and allow the elongation of the drive shaft while maintaining the watertight integrity. **The hinge assembly is a vital component and needs to be in place for the entire system to function safely.** Proper installation and alignment of the housing seals is a key factor in safe operation. All mechanics and inspectors "including the drivers" should be trained to detect a properly installed seal. Attention should be given to the seal clamp rings to determine tightness or misalignment that could lead to housing seal failure.

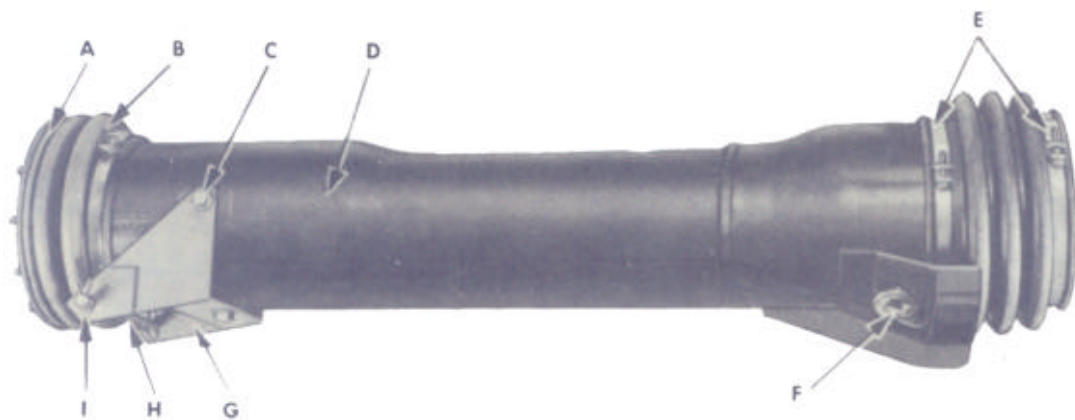

- | | |
|------------------------------------|-------------------|
| A. Seal Retaining Ring | F. Drain Plug |
| B. Housing Seal | G. Hinge Assembly |
| C. Hinge Cap Screw and Lock Washer | H. Hinge Pin |
| D. Shaft Housing | I. Cotter Pin |
| E. Seal Clamp Rings | |

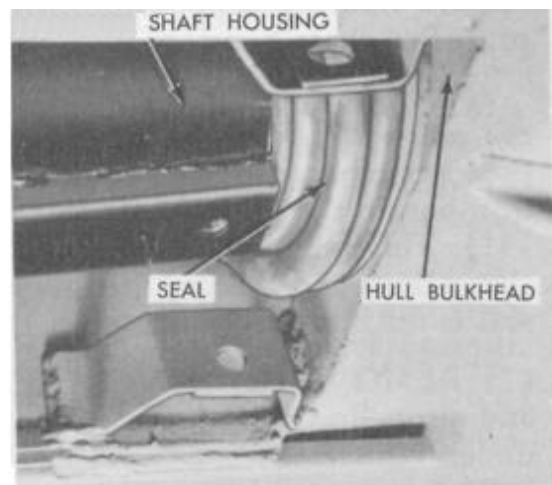
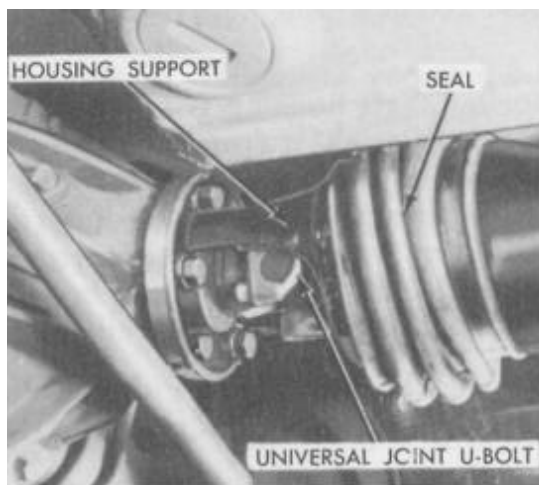

- C. Commercial Passenger Carrying DUKWs: After World War II these amphibious vehicles were retired from military service and a growing number of commercial entities began restoring and modifying them for use as novelty tour vehicles. At the time of this writing, approximately 75 DUKWs were inspected to Subchapter T and 140 DUKWs were reported as being operated as uninspected vehicles.

The modification of a DUKW for commercial passenger service presents a unique challenge. The owner and regulatory bodies must evaluate a vehicle that operates in two separate environments. The vehicle must meet both land and sea regulatory requirements. Whenever any modification is made from the original design it must be evaluated considering the impact on both the land and water operation.



(Modified DUKW for passenger service)

The following is a list of some of the more typical modifications found on existing DUKWs employed in passenger service. Obviously, not all modifications took into consideration all aspects of land and water operations or safety.

- Removal of interior framing, bulkheads, and or exterior reinforcement ribs.
- Removal of the rear coaming in the primary cargo compartment.
- Removal of the winch with associated drive lines and other accessories.
- Removal of the original engine and installation of a gasoline V8 or diesel engine.
- Removal of the original manual transmission and installation of an automatic transmission.
- Removal of the drive train, aft shaft housing and differential serving the after rear axle.

- Removal of the drive train intermediate shaft housing and differential serving the intermediate axle.
- Removal of the drive shaft housing hinge assembly.
- Removal of the drive shaft housings with modifications to the drive shafts to accept the installation of a through hull carrier bearing.
- Conversion of the electrical system to 12 volts.
- Removal of the tire pressure control system.
- Removal of the forward bilge pump and disabling the original Higgins bilge pump.
- Installation of electric submersible bilge pumps.
- Raising and lengthening the canopy, making it high enough to allow persons to stand.
- Installation of racks in the canopy for storage of life preservers.
- Installation of windows, to provide shelter from the weather.
- Installation of school bus type seating, outboard of a centerline aisle with reduced aisle width and spacing.
- Installation of a hinge mounted ladder on centerline at the stern, for boarding the vehicle while on land.
- Installation of additional railings.

D. Lessons Learned from the MISS MAJESTIC Casualty: On May 1, 1999 the MISS MAJESTIC (a converted 1944 DUKW, inspected to 46 CFR, Subchapter T) sank in Lake Hamilton, Hot Springs, AR with the loss of 13 passenger lives. A Marine Board of Investigation determined that the vehicle sank rapidly by the stern in less than 30 seconds after the master recognized the vehicle was in distress.

The Marine Board of Investigation determined the root cause of this casualty to be the unchecked flooding resulting from the intermediate shaft housing aft seal dislodging from the shaft housing at the start of waterborne operation. Contributing causes were found in the method of shaft housing seal installation, lack of high bilge alarms, failure of the Higgins bilge pump, and passenger entrapment. The Marine Board also expressed concerns with the lack of watertight testing after repairs to the hull or watertight appendages. (The complete Marine Board of Investigation Report can be found at <http://www.uscg.mil/hq/g-m/moa/boards/dukwn.pdf>) Many causal factors discovered in the investigation could have been easily rectified. It is highly recommended that all marine inspectors and vehicle owners/operators read and study this report. The findings of the Marine Board are insightful and recommend both industry and Coast Guard improvements.

The Marine Board of Investigation revealed a general lack of knowledge concerning the operation and function of various parts of a DUKW on the part of all parties involved. The MISS MAJESTIC's shaft housing had been altered by removal of the hinge assembly. This was probably done to facilitate maintenance of the U-joints of the intermediate drive shaft and the misconception that the hinge assembly was a skid

Enclosure (1) to NVIC 1-01

plate. The hinge assembly as originally installed provides three vital functions: supports the weight of the shaft housing, positions the shaft housing to prevent drive shaft and housing contact and prevents the shaft housing from shifting fore or aft. Without the hinge assembly the shaft housing seals bear all these burdens; they were not designed for this nor intended. Any alteration to these assemblies should be viewed with great caution. Being that these assemblies have now been shown to be susceptible to improper maintenance and misunderstanding, closer examination of these assemblies is needed.

The Marine Board of Investigation revealed a general lack of prudent marine practice in the maintenance of the MISS MAJESTIC. The boot seals for the intermediate shaft housing had been recently replaced; however the vehicle was not subsequently tested. The shaft housing seals form a critical component in the watertight envelope of a DUKW. As such, in-water testing must be done to verify the adequacy of any repair affecting the watertight envelope and ensure watertight integrity prior to operating the vehicle as a vessel with passengers.

The Marine Board of Investigation revealed the required bilge high level alarms had not been installed. The Coast Guard stressed throughout the regulatory evolution of new Subchapter T the need for these alarms. Reviews of casualties indicate that a contributing cause of many sinkings and foundering is undetected flooding. The time to discover that a vessel is taking on water is not when it starts to feel or move differently. The need for properly installed and functioning bilge level alarms cannot be overstated.

The Marine Board of Investigation also revealed that the Higgins propeller shaft driven chain drive bilge pump had been damaged and rendered nonfunctional.

The last area in which the Marine Board of Investigation revealed a serious problem was in the method of egress from the vessel. MISS MAJESTIC sank rapidly stern first forcing the passengers into the canopy and toward the windshield. The windshield was locked in the up position and the canopy came to the top of the windshield. Further, vinyl side windows had been installed to the sides of the windshield. The passengers were trapped. When evaluating the canopy design, side windows and windshield, all should be viewed together and provide ready egress. Arrangements should be in place to allow all of these areas to be open or readily opened with minimal effort, generally by a simple action.

III. REFERENCES

The following may be helpful as reference material during the operation and certification of these vehicles.

- A. Title 46, Code of Federal Regulations, **Subchapter T** (Parts 175 - 187). These regulations govern the certification process and are for sale by the U.S. Government Printing Office, Mail Stop: SSOP, Washington, DC 20402-9328, contact the GPO Order Desk at (202) 512-1800. They can also be found in a downloadable format at <http://www.gpo.gov/nara/cfr/cfr-table-search.html#page1> under the section for Title 46, Shipping.
- B. Navigation and Vessel Inspection Circular 7-68, (**NVIC 7-68**), "Notes on Inspection & Repair of Steel Hulls" was published by the Coast Guard to provide guidance information relating to good practice in the inspection and repair of steel hulled vessels. This publication can be purchased from the National Maritime Center (NMC), 4200 Wilson Blvd, Suite 510, Arlington, VA 22203-1804, telephone number (202) 493-1052 or can be downloaded from http://www.uscg.mil/hq/g-m/nvic/7_68/n7-68.pdf
- C. American Boat and Yacht Council (ABYC), 3069 Solomon's Island Rd., Edgewater, MD 21037, contact (410) 956-1050; Project **P-1-93** "Installation of Exhaust Systems for Propulsion and Auxiliary Machinery" and Project **P-4-89** "Marine Inboard Engines"
- D. The War Department published several Technical Manuals for the operation, maintenance and repair of DUKWs. These manuals provide a wealth of knowledge and should be viewed as the prime source for information concerning the original equipment. The manuals listed below can be purchased from private vendors or through the Library of Congress. They can also be found in Federal Depository Libraries and in large Army libraries such as the Pentagon Library or the library at the Military History Institute at Carlisle Barracks, Pennsylvania. These facilities may be willing to make loans through the Interlibrary Loan System.
 - **TM 9-802**, 45. 2 1/2 ton, 6x6, Amphibian Truck (GMC DUKW-353), 533 pages. PB 38808 - BSIR 3(4):289; 10/25/45
 - **TM 9-1802B**, 43. Power Train for 2 1/2-ton Amphibian Truck, 6x6 (GMC DUKW-353), 280 pages. PB 62824 - BSIR 5(4):304; 04/25/47
 - **TM 9-1802C**, 43. Hull and Water Drive for 2 1/2-ton 6x6 Amphibian Truck (GMC DUKW-353), 270 pages. PB 80619 - BSIR 7(1):63; 10/03/47

In February 2000, the Coast Guard Office of Investigation and Analysis (G-MOA) compiled the Marine Board Report of the M/V MISS MAJESTIC, TM 9-802 and TM 9-1802C on a CD and distributed to all Coast Guard Marine Safety Offices and to all DUKW operators.

IV. GUIDELINES FOR CERTIFICATION

The Coast Guard's approach to the certification of DUKWs shall be through a systems approach. The complete vehicle must be considered as providing an equivalent level of safety to other vessels certificated under Subchapter T. When a DUKW cannot meet a particular design requirement, equivalencies and or operational controls should be considered. This methodology must be employed during the entire certification of the DUKW. The following guidelines should not be used as a checklist. Each section within these guidelines must be viewed in the context of the entire vehicle, remembering the "systems approach."

A vehicle's regulatory history must be properly documented to ensure a complete and accurate inspection history exists. Any departures from regulations, equivalencies and special considerations must be documented in the Coast Guard electronic records (MSIS).

Due to the unique design and operation of these vehicles, OCMI's should assure marine inspectors have received proper training regarding the operation and inspection of these vehicles. If needed, the Coast Guard Quality Assurance & Traveling Inspection Staff (G-MO-1) is available to assist and advise.

The following is a review of Subchapter T with suggested guidance:

- A. **GENERAL PROVISIONS, 46 CFR Part 175** - This part should be applied in its entirety with no exceptions or additional requirements. Attention should be drawn to 175.550. Owners and operators should be advised that "Special Consideration" is contingent upon the approval of each OCMI, as operating conditions often vary between zones. This will affect all vehicles that operate or receive certification in multiple OCMI zones.
- B. **INSPECTION AND CERTIFICATION, 46 CFR Part 176** - This part should be applied in its entirety with the following exceptions or notations:

176.110 - Routes permitted.

The permitted route of a DUKW must be carefully considered. An evaluation of the vehicle's design, equipment, proposed route, in-water operating conditions, and other potential adverse circumstances must be made to determine a safe route. Items to consider in making this determination include; intact stability, potential for down flooding, rate of flooding due to hull breach at shaft penetration,

operator experience and competence, potential environmental conditions (sea state, current, wind) distance from shore, potential landing sites, other marine traffic...etc.

Due to the minimum freeboard of these vehicles and stability concerns (see section D below) they should be restricted to protected waters to lessen the possibility of down flooding over the stern.

Due to the minimum thickness of the steel used in the hull of these vehicles they should not be permitted to operate under icing conditions.

176.112 - 113 – Total persons permitted / Passengers permitted.

The number of passengers permitted should be determined through the fixed seating criterion. This is necessitated by other considerations that will be explained further in this guide (reduced aisle width, seat width, lowering of deck railing...etc). To determine the total persons permitted, an evaluation of the stability, location of passenger seats and manning will be required.

176.402 - Initial Inspection for Certification

There are no special considerations for this section; all owners and operators should comply with the requirements of this section regarding the submission of plans, manuals and calculations indicating the proposed arrangement, construction, and operations of the vehicle to the OCMI or to the Coast Guard Marine Safety Center (MSC). All materials, workmanship and the condition of existing machinery and equipment are subject to the approval of the OCMI.

176.404 & 176.502 - Inspection for Certification and Annual Inspections

During all inspections for certification and reinspections the vehicles shall be operated in the water and all through-hull penetrations shall be examined for watertight integrity. The entire exterior of the hull should receive a visual examination and all mechanical equipment should be operationally tested or simulated to determine its suitability and condition for service.

Areas of particular interest or concern include:

- The wheel wells, which could deteriorate from road spray.
- The bow and stern which could receive damage from water entry / landings or from on-land vehicular accidents.
- The propeller shaft V-strut and its connection to the hull.
- The propeller shaft journal in the V-strut, which is held together by cap screws and secured by a lock wire.

Enclosure (1) to NVIC 1-01

- The shaft housing hinge assemblies including the hinge pins and retaining cotter pins.
- The structural condition of the shaft housings.
- The condition of the shaft housing seals and seal clamp rings.
- Condition of all hull penetrations.
- The condition and function of all bilge pumps.
- The condition of the drive chain for the Higgins bilge pump. If not properly adjusted it could rub against the hull damaging both.

In order to conduct an exterior examination of the shaft housing seals the seal needs to be extended to its fullest in-service extension. This can be accomplished by jacking the vehicle. For examination of the intermediate shaft housing seals the aft axle should be jacked till it meets its stops. This will cause the intermediate drive shaft to extend to its fullest allowing an adequate visual examination of the seals. To examine the aft shaft housing seals, the intermediate axle should be jacked. While the shaft housing seals are extended they should be examined for the following:

- Loose, misaligned or missing seal retaining rings.
- Ballooned or otherwise deformed arches.
- Spongy feeling of the joint body.
- Loose outer body fabric.
- Hardness and cracking of the cover.
- Cracks at base of an arch
- Cuts and gouges in the cover.

176.610 – Scope of drydock and internal structural examinations

A modified drydock examination shall be conducted in coordination with the Inspection for Certification or Reinspection. Particular attention should be paid to all internals, frames and the areas of the hull concealed by framing, flooring and the areas around the driveshaft and propeller tunnels.

The shaft housing seals should be externally examined and internally examined if practical. The shaft housing seals shall be removed for further examination or testing if in the opinion of the marine inspector the condition is questionable. The drain plugs should be examined verifying proper fit and function. After the completion of all hull exams for credit these vehicles should be operated in the water to insure watertight integrity. Additionally, the transfer case, transmission, propeller shaft pillow block, steering gear and the water propeller transfer case should be inspected to insure that they are intact and serviceable.

176.612 - Notice and plans required

All owners and operators of DUKW vehicles are required to report to the OCM I any time the vehicle undergoes repairs or alterations affecting the safety of the vehicle. Hull repairs or alterations that affect the safety of the vehicle include, but are not limited to, the replacement or repair of plating, structural members (including the repair of cracks) or the replacement or removal of any shaft housing seals. When a shaft housing seal is removed or replaced, or if the vehicle is involved in a collision on land, the owner or operator of the vehicle shall notify the OCM I prior to operating the vehicle in the water with passengers.

All repairs are subject to further inspection and may require testing by a Coast Guard marine inspector. The vehicle may be required to operate underway during the inspection of any repairs.

There is no need to notify the OCM I when the vehicle is hauled out of the water during normal operations.

C. CONSTRUCTION AND ARRANGEMENT, 46 CFR PART 177 - Applicable in its entirety with the following exceptions or notations:

177.310 - Satisfactory service as a design basis

The structural design of a DUKW does not conform to the standards listed in 177.300. Generally, Coast Guard approval of the DUKW's scantlings has been based on the vehicle's satisfactory service since World War II. As part of the MISS MAJESTIC casualty investigation, the MSC conducted a structural analysis of the DUKW. The structures were analyzed using a combination of the American Bureau of Shipping Rules for Steel Vessels <200' and engineering first principles. This analysis determined that the DUKW's hull structure provides adequate safety and strength for operations in relatively benign environments (protected waters), and would be approved if constructed as a new vehicle provided it was built to the original design scantlings established by the War Department. Technical Manual **TM 9-1802C** should be used as the standard for these vehicles.

Enclosure (1) to NVIC 1-01

The exact gauge steel used in the original construction of these vehicles is a subject of debate. Repairs to the hull should be made in kind, if the original thickness can be determined. As a general guide the following is suggested but is not definitive.

Bow Bottom Plating	= 12 gauge
Center Bottom Plating	= 13 gauge
Stern Bottom Plating	= 12 gauge
Water Propeller Shaft Tunnel	= 12 gauge
Axle Propeller Shaft Tunnels	= 13 gauge
Wheelhousings (Wheel Wells)	= 13 gauge
Hull Sides	= 14 gauge

Cold Rolled Carbon Steel Sheet

Gauge	Inch equivalent	Tolerance Range
10	0.1345	0.1405 – 0.1285
11	0.1196	0.1256 – 0.1136
12	0.1046	0.1106 – 0.0986
13	0.0897	0.9400 – 0.0847
14	0.0747	0.0797 – 0.0697
15	0.0673	0.0723 – 0.0623
16	0.0598	0.0648 – 0.0548
17	0.0538	0.0548 – 0.0498
18	0.0478	0.0518 – 0.0438
19	0.0418	0.0458 – 0.0378
20	0.0359	0.0389 – 0.0329

Caution should be exercised when making any alteration to the hull. The original design took into consideration the interaction of road stresses on a truck chassis as well as the waterborne stresses on the hull. The hull must be able to flex with the chassis to prevent hull failure. Interior framing, bulkheads, and exterior reinforcement ribs all contribute to the rigidity of the hull. The addition of bulkheads to increase survivability should be closely evaluated and monitored. Additional bulkheads could induce stresses into the hull or chassis and lead to the failure of either.

177.405 - General arrangement and outfitting

Plywood decking commonly used in DUKWs does not provide a vapor tight boundary between the machinery and fuel tank spaces and the passenger space. However, the engine-cooling fan provides negative air pressure under the floorboards and minimizes the accumulation of fumes in the passenger spaces. This, combined with the vapor detection system required by section 182.480, should be viewed as an acceptable level of safety. In addition, smoking shall be

prohibited on DUKWs powered by gasoline engines. The master should include a no smoking statement in the safety orientation required by 185.506.

177.500 - Means of escape

Due to the size of a DUKW, 177.500(o) requires only one means of escape. Most DUKWs have been granted special consideration for reduced aisle widths with the stipulation that the primary means of escape is over the side. This goes against human nature, which is to exit in the same manner one enters. The method of boarding, for the majority of DUKWs, is over the stern; hence the perceived escape is over the stern. These vehicles have a tendency to sink stern first. This places the perceived escape in the opposite direction from which the passengers should go. Because of this, the master should give specific instructions to the passengers during the safety orientation concerning the method of escape from the vehicle. Side windows or curtains, if installed, should be able to be opened with minimal force, generally by a simple action by one person.

Canopies and canopy supports can impede the egress of passengers. Again, the primary egress on these vehicles is over the side. Canopy supports should be positioned to allow the majority of passengers unobstructed egress. If a canopy support is located directly adjacent to a passenger's seat it should be shown, through a practical test, that the passenger can adequately egress the vehicle. The window framing vertical distance should be sufficient for a passenger to exit while wearing a lifejacket. A vertical distance of 32 inches from gunwale to canopy appears sufficient for most installations. Overhead storage of lifejackets should not impede the egress of passengers.

177.820 – Seating

Because of the limiting design and construction of DUKWs and relatively short in-water operations on protected waters, these vehicles should be granted special consideration from the aisle width and fixed seating criteria. Aisle widths may be allowed to be reduced to no less than 14 inches and the fixed seating criteria to no less than 17 inches per passenger. In addition, the distance from seat back to seat back may be reduced from 30 inches to 28 inches.

177.900 - Deck rails

In light of the casualty involving loss of life aboard the MISS MAJESTIC, adequate egress is a major issue with DUKW vehicles. With special consideration being given to seat spacing and aisle widths, and the close proximity of PFDs stowed directly above passengers, the most immediate egress route is over the side. This method of egress may be significantly hampered by the 39.5-inch rail/bulwark height requirement. Therefore, under 177.900(f), the OCMI should consider the original bulwarks in way of the passenger seats within

the recessed compartment of the DUKW as acceptable in meeting the rail height requirements. Increasing the rail heights should not be allowed, as this would restrict the multiple egress routes over the side. To compensate for the reduction in railing, a requirement advising the passengers to remain seated, unless under the direct observation of the master, should be placed on the COI. The master should include a “passengers must remain seated” statement in the safety orientation required by 185.506. The rails on the back deck of the DUKW, where passengers are generally loaded and unloaded, should meet the 39.5-inch height requirement unless this area is also being used for seating.

177.1010 – 177.1030 – Window Construction and Visibility

If side windows or curtains are installed they should not cause an impediment to passenger egress. Arrangements should be in place to allow the master the ability to open all windows and or curtains on each side from a point located at the control station.

In the extreme case of a vehicle sinking, the windshield can entrap passengers. For this reason the windshield should be designed to fold down with minimal force to allow egress.

During the passenger safety orientation the master should address vehicle egress in relation to the windows / curtains and windshield.

D. INTACT STABILITY AND SEAWORTHINESS, 46 CFR PART 178 –

A stability study was conducted by the MSC to determine the operational limitations of a modified DUKW intended for passenger service based on stability considerations. The study focused on determining a limiting route, maximum load based on this route and whether the simplified stability test remained valid to determine the stability of these vehicles.

Results indicate the simplified stability test provides an adequate measure of the vessels intact stability characteristics provided the following items are met:

- The vehicle is considered an open boat.
- The route is restricted to a protected route.
- The freeboard is measured at a point three-quarters of the vessel’s length from the bow.
- The freeboard at the stern during operations should never be less than the freeboard measured at the stern during the simplified stability test.

The MSC should be consulted for any deviations from the above criteria.

Careful consideration should be given to applying results to a “sister” vessel due to the use of various engines, transmissions, suspension and other components, which could effect trim and heeling moments.

The minimum freeboard at the stern should be stated on the vehicle’s Certificate of Inspection and/or Stability letter. In addition a permanent mark, such as a welded bead or center punch, painted in a contrasting color to the hull, should be placed on the stern indicating this position. The mark should be a horizontal line at least 8 inches in length and 1 inch in height, with its upper edge passing through the point of minimum freeboard.

- E. **SUBDIVISION, DAMAGE STABILITY, AND WATERTIGHT INTEGRITY, 46 CFR PART 179** - This part is not applicable to DUKWs since they are less than 40 feet in length, operate on protected waters on domestic routes and carry less than 49 passengers. However the following are industry best practices and are listed as ways to increase watertight integrity and decrease the risk of uncontrolled flooding. Industry representatives have been designing appliances to reduce or eliminate the possibility of flooding through the shaft housing hull penetrations. These methods can be used to decrease the bilge pump capacity requirements and add to the survivability of the vehicle. Two devices to date are a Restrictor Plate and a Carrier Bearing.



Restrictor Plate
(Front view)

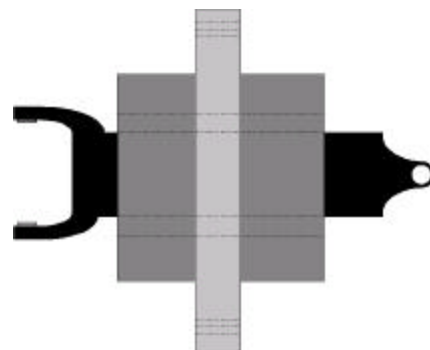

Carrier Bearing
(Side view)

The Restrictor Plate is made from either a rigid rubberized product or steel that is installed in the drive shaft hull penetration. The drive shaft penetrates the Restrictor Plate and accommodates the movement of the shaft. This device greatly reduces the size of the through hull penetration and can be installed without significant modification to the original arrangement.

In the case of the steel Restrictor Plate, careful measurements and installation must be exercised to avoid making contact with the drive axle. Steel Restrictor Plates have been designed with an oval opening of 2 1/2 inches by 4 3/8 inches leaving 1/4 inch of clearance in all directions.

Enclosure (1) to NVIC 1-01

The Carrier Bearing installation is an engineered device that extends the drive shaft flexing point exterior to the hull thereby eliminating the need for the shaft housing and seal assemblies. It consists of a drive shaft, bearings, housing, and hull attachment body. It can be bolted to the hull where the seal retaining ring and shaft housing seal were previously bolted. Redesign of the attaching drive shafts may be required. This device completely closes the through hull penetration removing it as a source of possible flooding. The Carrier Bearing mounts where the original through hull shaft housing seal was located. This area of the hull was not originally designed to handle torque loads. If this area is overstressed due to the land operation of the vehicle it may cause drive shaft failures or hull fractures.

Any alteration to the design of the DUKW must be carefully evaluated and monitored. Due to the interaction of the amphibious components of the vehicle, it is easy to solve one problem and unintentionally create another.

It is extremely important to consider the entire land and sea operation of the vehicle specific to its geographic operating area.

One final method that is not mentioned above is the redesign of the shaft housing seals and attachments to accept seal double clamp rings. While this method has merit in securing the shaft housing seals it does not increase the survivability of the DUKW due to a shaft housing seal failure.

179.240 - Foam flotation material.

If foam flotation is placed in a vehicle it should be installed to the specifications in this section. Although foam flotation can augment subdivision, foam installation generally tends to aggravate maintenance problems by restricting access. A vessel designed without foam flotation is much easier for the owner to maintain and the Coast Guard to inspect. Foam flotation should be installed to allow removal for inspection on a regular basis. Being that foam flotation deteriorates with age, periodic sampling to determine the density and condition of the material is needed to ascertain its condition. The specific procedure for testing should be determined prior to installation. Because installations of foam flotation varies in detail, adequate inspection requirements are best determined on a case-by-case basis. To ensure consistency over time, the method of testing, baseline criteria and follow-up testing should be maintained by the owner and recorded in the Coast Guard electronic records (MSIS).

F. LIFESAVING EQUIPMENT AND ARRANGEMENTS, 46 CFR PART 180 -

The vehicles should meet all applicable requirements of this part.

Vehicles operating within protected waters (ie...Lakes, Bays, and Sounds and River routes) must carry distress flares and smoke signals unless they are on short runs limited to approximately 30 minutes.

Vehicles are required to carry at least one ring buoy of not less than 24 inches in diameter, fitted with a lifeline of 60 feet, that is readily accessible and stowed in a way that it can be rapidly cast loose. OCMIs should consider requiring 2 ring buoys each with 60 feet of lifeline, one located at the operating station and one located in the aft section of the vehicle each for immediate use. If the vehicle is limited to daylight operations the ring buoy does not need to be equipped with a waterlight.

Life jackets must be stowed in convenient places distributed throughout the accommodation space and be readily available. If practicable, the stowage should allow the life jackets to float free.

G. FIRE PROTECTION EQUIPMENT, 46 CFR PART 181 -

The vehicles should meet all applicable requirements of this part. To inhibit the dispersal of the extinguishing agent from the machinery and fuel tank spaces, all reasonable steps should be taken to minimize the number of penetrations in the deck beneath the operating station, and throughout the passenger space. This may include the use of boots or other flexible material around pedals and gearshifts and recessed handles in the floorboards vice hand holes.

181.400s – Fixed Fire Extinguishing and Detecting Systems

Fire suppression on a small passenger vessel follows a four-step process.

- Detection of the fire.
- Cessation of all mechanical means that remove air for the space (exhaust blowers and or engine intakes).
- Manual closure of all ventilation supplies and exhaust discharge openings.
- Release of the fire-extinguishing agent.

The following chart provides a comparison of allowed installations and shutdowns.

Fixed Fire Extinguishing Systems

SYSTEM TYPE	ACTIVATION of SYSTEM	AUTOMATIC MECHANICAL VENTILATION SHUTDOWN	AUTOMATIC PROPULSION MACHINERY SHUTDOWN	FIRE DETECTION SYSTEM
1. Portable/Semi-portable 46 CFR 181.400(b)(5) Storage cylinder for agent <u>outside</u> the protected space	Manual	No (1) (Manual)	No (1) (Manual)	Yes
2. Custom Engineered 46 CFR 181.410 Storage cylinder for agent <u>outside</u> the protected space	Manual	No (2)	No (2)	Yes
3. Pre-engineered 46 CFR 181.420 Storage cylinder for agent <u>inside</u> the protected space	Automatic	Yes	Yes (<u>Unless</u> the propulsion machinery has a direct air intake from outside the protected space)	Yes (3)

- (1) Marking instructions required by 46 CFR 185.612 direct the operator to secure ventilation and machinery prior to discharge of the fixed system.
- (2) The notation of "No" for automatic shutdowns on a manually activated, custom-engineered fixed gas fire extinguishing system is not to be interpreted as meaning that shutdowns are not required or that a manual shutdown system is acceptable. On a manually activated, custom engineered fixed system, only the activation of the fixed system itself is manual. The manual activation of the fixed system then activates automatic mechanical ventilation shutdowns and propulsion machinery shutdowns if the propulsion machinery draws its intake air from within the protected space prior to discharge of the agent.
- (3) Automatic discharge upon heat detection meets this requirement.

Enclosure (1) to NVIC 1-01

Operators should consider highway requirements and land use when selecting the type of fire extinguishing system. Pre-engineered automatic systems may be required to shutdown the engine when activated. This could pose a safety hazard if the DUKW is equipped with power steering and or brakes and the shutdown occurs in traffic.

Due to the open nature of these vehicles from the engine space under the passenger space and into the stern compartments, this entire “below deck area” should be used in calculating the amount of extinguishing agent needed.

The simple instructions for the use of the fixed fire extinguishing required by 185.612(a) should be within ready view of the operator.

181.500 – Portable Fire Extinguishers

Since the DUKW is an open boat with the operating station in close proximity to the machinery space and contained in the passenger space, the requirements of table 181.500(A) appear excessive. OCMI's should consider allowing these vehicles be equipped with two portable fire extinguishers: one B-I and one ABC-II.

H. **MACHINERY INSTALLATION, 46 CFR PART 182** - Applicable in its entirety with the following exceptions or notations:

Attention should be given to the installation of machinery. Being that these vehicles were originally designed from military trucks, they were not outfitted with equipment needed for commercial passenger service in the maritime environment.

Gasoline engines with carburetors are required backfire flame arresters bearing basic approval numbers 162.015, 162.041, 162.042, 160.043 or as an alternative meet either industry standard SAE J-1928 or UL 1111.

Gasoline engines with air and fuel induction systems should meet basic approval numbers 162.042, 162.043 or as an alternative meet industry standard SAE J-1928.

182.420 - Engine cooling

Amphibious vehicles present a unique challenge to a vehicle engineer to provide a propulsion engine that can function on both land and water. DUKWs were originally outfitted with radiator cooled gasoline engines because the vehicle is based on a truck design and would see the majority of its use on land. Policy was

established in the Coast Guard Marine Safety Manual permitting this arrangement, provided a temperature alarm and remote indicator were installed. Through the evolution of Subchapter T, 182.420(c) was written to allow air cooled gasoline propulsion engines provided that no more than 12 passengers are carried and the system is in compliance with ABYC P-4. This standard provides guidance on the design and construction of cooling systems, ducting, electrical systems, fuel systems, carburetors and instrumentation. In consideration of past allowances and the multi-use nature of these vehicles, compliance with ABYC P-4 should be sought and the passenger restriction of 182.420(c) be lifted.

ABYC P-4.5.7 states *“If the engine or its components are installed in normally occupied spaces, protective guards, jacketing, or engine boxes shall be provided wherever persons or gear might come in contact with exposed surface temperatures of the engine, or its components, that exceed 200°F.”* The use of the word *“normally”* refers to activities other than maintenance or engine repair. Under this provision, the engine, which is located in a separate compartment, would only be required to install the above items if gear were stored in the engine compartment.

Cooling of the engine has posed problems for operators during high ambient temperatures or in mountainous terrain. One solution has been to mount the engine compartment hatch cover in the open position to provide additional airflow. This solution should be approached with caution because it will involve the addition of closure devices in the case of activation of the fixed fire extinguishing system.

Problems have also been encountered during waterborne operations where the engine is required to operate continuously at full speed. Mounting the engine compartment hatch cover in the open position has provided relief but poses the same problems as mentioned above. An alternate solution may be the installation of supplemental keel coolers.

182.425 - Engine exhaust cooling

These vehicles have dry exhaust systems, which should be installed in accordance with 182.425 (a)(2), 177.405(b) and 177.970 or meet ABYC P-1-93 "Installation of Exhaust Systems for Propulsion and Auxiliary Engines." These regulations and standards provide guidance on methods to reduce fire risks and the protection of personnel through the use of insulation. The exhaust system should be removed as a source of ignition through the use of insulation, unless it is installed in such a location that combustibles or a person could not come in contact with the system. In applying this section the exhaust system starts at the outlet of the exhaust manifold of the engine, or the turbocharger if used, and continues through to the terminus where the exhaust gases are discharged.

182.440 - Independent fuel tanks.

The original fuel tank on these vehicles was designed for land use and are acceptable provided they are still serviceable. Any new installations should be required to meet the original specifications or the requirements of this section.

Whether a new or original fuel tank is installed the requirement for shutoff valves in the fuel supply lines (182.455(b)(4)) should not be overlooked. This regulation requires a shutoff valve at the tank connection, which can be manually operated from outside the space, and one at the engine end of the supply line.

182.450 - Vent pipes for fuel tanks.

The original automotive fuel tank, vent, fill pipe and cap are acceptable if the vehicle is fueled on land and there is no danger of a tank overflow into the waterway. The vehicle is not required to install marine type vents on its fuel tank unless it is fueled in the water. If marine type fuel tank vents are not installed the vehicle's COI should include an endorsement restricting the vehicle from fueling while in the water.

182.460 - Ventilation of spaces containing machinery powered by, or fuel tanks for, gasoline.

The cooling air circulation system of a DUKW enters the engine compartment through air intake grilles located between the operating station and passenger space. The air is drawn forward under the operating station into the engine compartment. The air is then drawn through the fan, pushed over the engine and exhausted through an air duct on each side of the engine compartment, finally being exhausted through an air exhaust grille located at each side of the operating station above the deck level. For vehicles operating under extreme conditions the engine compartment hatch cover is sometimes propped open to supply additional cooling.

All supply and exhaust grilles of this system, including the engine compartment hatch cover (if normally run open), require closures in the event of activation of the fixed fire extinguishing system. The closure mechanisms should be accessible from the operating station.

182.520 - Bilge pumps.

The Coast Guard's approach to a bilge system for small passenger vessels is for it **not** to serve as the primary deterrent against the ingress of seawater due to flooding. Structural integrity and through hull fittings provide the primary deterrent. The bilge system serves to evacuate accumulation that results from

normal vehicle operations. Table 182.520(a) states that a vessel of equivalent size to a DUKW would require 1 fixed power pump and 1 portable hand pump, each with a capacity of 38 LPM (10 GPM or 600 GPH).

The DUKW in military configuration was equipped with two distinct bilge pumping systems. The primary system, which was used for normal operations, was comprised of an Oberdorfer (geared) or Gould (centrifugal) pump. The emergency system was the Higgins propeller shaft driven chain drive pump. The capacity of the Higgins bilge pump is in excess of 250 GPM. This was to allow the vehicle to sustain damage and operate in difficult conditions defined by the War Department as surf at shore over 3 feet, wind over 15 mph and wave height at launching ship over 3 feet. The capacity of these bilge pumps is obviously for more than normal accumulations. These vehicles were designed for combat with the primary focus on placing cargo and troops on the beach at all costs. The design of the Higgins pump reflects this philosophy. Being driven off the water propeller shaft it is only at full discharge capacity when the vehicle is operating at full speed ahead. The master is forced to remain on station and fully depress the vehicle accelerator. Reliance on this pump during the carriage of passengers may not be practical for a one-crew operation if the master must leave the driver's seat to assist the passengers with donning life jackets or egressing the vehicle.

The potential for uncontrolled flooding in a DUKW is higher than for a traditionally designed vessel due to the multiple and unique hull penetrations for the drive shafts. The failure of one shaft housing seal could result in flooding in excess of 220 GPM. This increased risk was offset in the original design with the installation of the Higgins bilge pump, however full capacity is only attained when operating at full speed.

When evaluating the bilge system for a DUKW several items need to be considered: regulatory requirements, route, operational restrictions, equipment design parameters, and compensation for unique characteristics.

The methodology to be used in calculating the bilge pump capacity should be similar to that of the original military methodology. Provide bilge pumps for normal operations and for emergency operations, which can offset uncontrolled flooding of the largest penetration in the hull until the vehicle can be safely beached. However, all DUKWs are to meet the minimum requirements of 182.520.

The following process should be used in determining the minimum bilge pump capacity:

1. Calculate the reserve buoyancy of the vehicle; at most, the length of the vessel times the width of the vessel times the freeboard in feet. (Example: 30 x 8 x 1 = 240 cubic feet of volume. Since there are 7.5 gallons in a cubic foot, the reserve buoyancy is at most 1800 gallons)
2. Calculate the head distance. (Example: The head for the shaft housing penetration of the hull is the draft amidships, about 30 inches, less the radius of the shaft housing at its end, about 4 inches or about 26 inches at the start of flooding)
3. Determine largest hole diameter in inches. (Example: Calculate the area of the largest open penetration, subtract the area of the drive shaft leaving the true area of the hole. Take the area ($\delta d^2/4$) of a 5 inch diameter hole, subtract the area of a 3 inch diameter drive shaft running through it leaves the area of a 4 inch diameter hole).
4. Use the following formula to calculate the flooding rate through a simple hole.

$$\text{GPM} = 3600 \times A \times H^{1/2}$$

Where: GPM is flooding rate in gallons per minute
 A is the area of the hole in square feet
 H^{1/2} is the square root of the head in feet
 (Taken from the U.S. Navy Salvors' Handbook)

Hole diameter (inches)	Head (feet)	GPM	Time to flood 1800 gallons (minutes)
1	2	28	64
1	3	34	53
2	2	111	16
2	3	136	13
3	2	250	7
3	3	307	6
4	2	444	4
4	3	543	3

5. Adjust the simple hole flooding rate to account for the reduced flow (flooding rate) through a pip and /or an annulus. A reduction factor of about 0.5 is appropriate for the shaft housing and drive shaft arrangement on a DUKW. (Example: A calculated flooding rate through a simple hole of 440 GPM would be reduced to 220 GPM for flooding through a pipe and/ or annulus.)

Hence an originally equipped DUKW should have a bilge pump or pumps with a combined capacity of over 220 GPM to control flooding or it could sink in

Enclosure (1) to NVIC 1-01

approximately 8 minutes if left unchecked. If the vehicle has been altered through the installation of a Restrictor Plate, the hole diameter would be reduced allowing a lower capacity bilge pump. Due to possible variations in Restrictor Plates and drive shaft diameters, hole area and flooding rate calculations should be performed to determine pump size. If a Carrier Bearing were installed with the required drive shafts alterations the hole would be completely closed. With this installation no additional bilge pumps would be required.

Due to the configuration of the hull, the port and starboard stern compartments should be equipped with individual bilge pumps to evacuate normal accumulation.

182.530 - Bilge high level alarms.

Due to the configuration of the hull it is suggested that four bilge high level alarms be installed. One each in the port and starboard stern compartments, one in the central hull section and one located above the suction of the highest capacity bilge pump. This last alarm could be considered a failsafe and be positioned to indicate the failure of the bilge pumps to evacuate the water.

182.620 - Auxiliary means of steering

DUKW vehicles have an auxiliary means of steering through the front wheels. Under benign conditions this may prove sufficient. However, if the vehicle is to operate in strong currents it is suggested an operational test be conducted to ensure the vehicle can be maneuvered through the water with just the front wheels providing steering. If steering can not be achieved through the front wheels an emergency tiller arrangement should be provided.

I. **ELECTRICAL INSTALLATION, 46 CFR 183** - Applicable in its entirety with the following exceptions or notations:

DUKW vehicles were originally built with automotive type electrical systems that do not meet the standards outlined in 46 CFR Part 183. DUKW vehicles should at a minimum meet the requirements of 183.130(b) for cable and wiring requirements.

Any new installation or replacement of electrical equipment in a space containing machinery powered by gasoline or a fuel tank containing gasoline must be explosion-proof or ignition-protected, or be part of an intrinsically safe system.

J. VEHICLE CONTROL AND MISCELLANEOUS SYSTEMS AND EQUIPMENT, 46 CFR PART 184 - Applicable in its entirety with the following exceptions or notations:

184.500s – Subpart E --Radio

The majority of DUKWs operate in environments that do not require the installation of radiotelephones or radiotelegraphs. Vehicles operating only on the Great Lakes or waters of the U.S., not subject to tidal influence, are not required to have a radiotelephone. However, prudence dictates that the master of the vehicle should have some method to communicate with the home office and/or with other vessels in the area. OCMI's should strongly encourage the use of a communication system that best meets this objective.

If the vehicle is not equipped with a VHF radiotelephone and operates on any tidewater subject to the jurisdiction of the U.S. it should be limited to a route that does not exceed 1000 feet from the nearest land at mean low tide in accordance with 47 CFR 80.933 (a).

184.620 - Propulsion engine control systems

DUKW vehicles are not required to have a second independent means of propulsion control. All operators of vehicles without a second means of propulsion control must include in their emergency procedures, instructions for handling a propulsion failure.

K. OPERATIONS, 46 CFR 185 - Applicable in its entirety with the following exceptions or notations:

The manning of the vehicle should be determined by the OCMI and may consist of a master and no deckhands if the master of the vehicle is able to demonstrate that he/she can maintain control of the vehicle while conducting normal operations and during emergency situations such as man overboard, fire and flooding. Controls for the activation of the fire extinguishing system and for the bilge system should be operable from the operating station. Prior to granting a one-person operation, the OCMI should witness drills designed to simulate the above emergency situations. These drills should be conducted without the assistance of passengers. The OCMI should also take into consideration the route of the vehicle in relationship to special hazards, weather, waterway traffic, day and or night operations, and the type and availability of beaching locations.

If a one-person operation is permitted, the vehicle's operating station should be equipped with an adequate panoramic type rear view mirror for observation of the passengers.

Enclosure (1) to NVIC 1-01

In making manning determinations the OCMI should also consider the type of passengers carried. If large groups of unchaperoned children are carried, the assistance of a deckhand may be needed during emergency and non-emergency situations.

185.504 - Passenger count.

The passenger count is valuable information in search and rescue cases as well as in determining whether the number of passengers exceeds the number allowed by a vessel's COI. Confusion has existed as to who is a passenger. Title 46, United States Code § 2101(21) states a 'passenger' --

- "(A) means an individual carried on the vessel except
- (i) the owner or an individual representative of the owner or, in the case of a vessel under charter, an individual charterer or individual representative of the charterer;
 - (ii) the master; or
 - (iii) a member of the crew engaged in the business of the vessel who has not contributed consideration for carriage and who is paid for on board services."

Under this definition it is not important if the passenger paid for carriage nor does it include an age limit. All passengers need to be counted including non-paying infants.

185.506 - Passenger safety orientation.

The passenger safety orientation is an opportunity for the master to explain the safety equipment and features of the vehicle and those actions that should be taken if an emergency should arise. The following items should be in this orientation:

- The method of embarking and disembarking the vehicle under normal conditions.
- The method of disembarking the vehicle during emergency egress.
- The stowage location of the life jackets and ring buoy.
- The proper method of donning and adjusting life jackets including a demonstration of the proper donning of a lifejacket.
- The location of the instruction placards for life jackets and other lifesaving devices.

Enclosure (1) to NVIC 1-01

- The times that all passengers will be required to don life jackets (when hazardous conditions exist or as directed by the master).
- The location of emergency exits.
- The method of removing egress obstructions (windows or curtains).
- The location of the fire extinguishing equipment.
- Policy on remaining seated for the duration of the voyage unless directed by the master.
- Policy of no smoking at any time.

185.520 - 524 – Abandon ship and man overboard drills and training / Fire fighting drills and training.

These sections require the master to conduct sufficient drills and give sufficient instruction to the crew in the performance of abandoning ship, donning of life jackets, recovery of persons who have fallen overboard and in fighting fires. The drills are to be conducted as if the emergency actually existed. Each drill and training needs to be logged or otherwise documented so that it can be reviewed by the Coast Guard. Being that no set interval is specified in the regulations, it is the master and operator's responsibility to determine the amount of training needed. The proof of sufficient training will be verified during Coast Guard inspections.

Each owner/operator should be strongly encouraged to develop a company operations manual incorporating training standards, maintenance standards, operational standards and emergency response plans.

The training standards should state the company requirements that must be met to be a DUKW mechanic, driver, master and crew. The standard should cover pre-employment, post-employment and re-employment (seasonal). It should educate the employees on methods to identify potential safety problems in the wheels and axles, shaft housing, housing seals, propeller system, rudder system, hull integrity and mechanical operation. It should require the employee to demonstrate the corrective action needed during a man overboard, flooding, injury and vehicle casualty.

The maintenance standard should list all systems to be checked and their maintenance cycles. The maintenance performed should be properly documented in logs or check sheets and signed by the mechanic. It should describe a deficiency correction procedure and interaction with the operators of the DUKW. It should also include a statement describing conditions under which the DUKW should not be operated.

The operational standards should be linked to the maintenance standard and contain pre-operational and post operational examinations. Items, which should be examined prior to the carriage of passengers, include:

- Interior and exterior hull examinations looking for watertight integrity, damage, or hull corrosion.
- Examination of the drive train including the shaft housing, housing seals, housing seal clamps, hinge assembly, drive axles and wheels.
- Examination of the water propeller system including the shaft, V-strut, cotter pins and locking wires.
- Testing of the mechanical operation of the engine, steering, drive train, braking, electrical and bilge system.
- Examination of lifesaving equipment.
- Examination of firefighting equipment.

The emergency response plans should be available to assist company personnel in dealing with an emergency. Their primary purpose is to set in motion the necessary actions to end or minimize the effect of the emergency. Effective planning ensures that the necessary actions are taken in a structured, logical, and timely manner. Good marine practice dictates that vessel owners and operators should have response plans in place to deal with the following:

- crew duties and responsibilities
- loss of steering
- loss of propulsion
- method and locations for beaching
- collision and grounding
- medical emergencies
- evacuation
- man over board
- inclement weather
- fire
- break down
- flooding
- oil spills

In preparing response plans, consideration should be given to the geographical area of operation, the environmental conditions, the proximity of other vessels and suitability of any onshore or offshore facilities. These plans should identify local fire, ambulance, and search and rescue facilities, including local telephone numbers and

Enclosure (1) to NVIC 1-01

contact points. The plans should also address concerns associated with the above emergencies both in and out of the water as appropriate and include provisions for company drills and crew training.

- L. **SAMPLE COI ENDORSEMENTS** - The following endorsements are recommended for inclusion on the vehicle's Certificate of Inspection. These are only examples derived from the restrictions presented through this guidance. The OCMI must evaluate each vehicle and specific operating conditions when determining the appropriate endorsements.

---ROUTE PERMITTED AND CONDITIONS OF OPERATION ---

(body of water) FROM *(specific location)* TO *(specific location)* NOT MORE THAN *(distance, i.e. 1000 feet)* FROM SHORE.

THE VEHICLE IS NOT TO BE OPERATED IN THE WATER WHEN WINDS EXCEED *(wind speed, i.e. 25 knots)*, AND OR THE SEA STATE EXCEEDS ONE FOOT

THE VEHICLE IS NOT TO BE OPERATED WITH LESS THAN 17 INCHES OF STERN FREEBOARD.

VEHICLE'S VOYAGES ARE LIMITED TO THIRTY MINUTES IN DURATION. *(If not carrying distress flares and smoke signals.)*

VEHICLE LIMITED TO DAYLIGHT OPERATION ONLY. *(If not equipped with navigational lights.)*

PASSENGERS ARE TO REMAIN SEATED AT ALL TIMES UNLESS UNDER THE DIRECT SUPERVISION OF THE MASTER.

A CHILD-SIZE LIFE PRESERVER SHALL BE PROVIDED FOR EACH PASSENGER WEIGHING LESS THAN 90 POUNDS.

SMOKING OR THE USE OF OPEN FLAME IS PROHIBITED.

FUELING OPERATIONS ARE PROHIBITED ON WATER, UNLESS THE REQUIREMENTS OF 46 CFR 182.445 AND 182.450 ARE MET.

IF PASSENGERS ARE ON BOARD OR HAVE ACCESS TO THE VEHICLE FOR A PERIOD EXCEEDING TWELVE HOURS IN A TWENTY-FOUR HOUR PERIOD, AN ALTERNATE CREW SHALL BE PROVIDED.

Enclosure (1) to NVIC 1-01

ANY TIME THE WATERTIGHT INTEGRITY OF THE VEHICLE IS
COMPROMISED THROUGH DAMAGE, REPLACEMENT, REPAIRS, OR
MAINTENANCE, THE OCM I SHALL BE NOTIFIED AND THE VEHICLE
SHALL BE SUBJECTED TO AN OPERATIONAL IN-WATER TEST PRIOR
TO CARRYING PASSENGERS.
