



ESD Initiated Failures on High Voltage Satellites

Ira Katz

V. A. Davis

Maxwell Technologies Inc., San Diego, CA 92123

David B. Snyder

NASA Lewis Research Center, Cleveland, OH 44140

Ernest A. Robertson

Space Systems/Loral, Palo Alto, CA 94303

Space Environments & Effects
Flight Experiments Workshop

Huntsville, Alabama

June 23-25, 1998

PVA Anomalies on Recent Satellites

- Tempo 2
 - GEO- launched in March, 1997
 - 10.5KW GeAs/Ge array
 - several strings shorted
 - 2.1 - 2.7A, 100V
 - power loss > 20%
- PanAmSat
 - launched in July, 1997
 - power loss > 20%
- Other satellites with silicon arrays are in orbit
 - slightly different layout
 - only 1 anomaly



ESD Initiated Failures on High Voltage Satellites

- On-orbit Anomalies
- Spacecraft Charging Analysis
- ESD Triggered Failure Mechanism
- Laboratory Results
- Prevention Measures
-

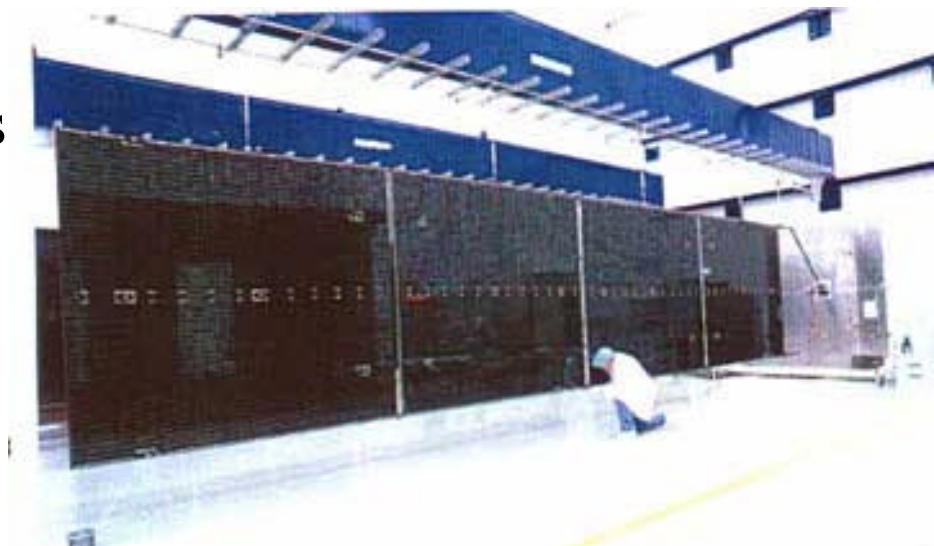

Anomalies are Correlated Magnetospheric Substorms

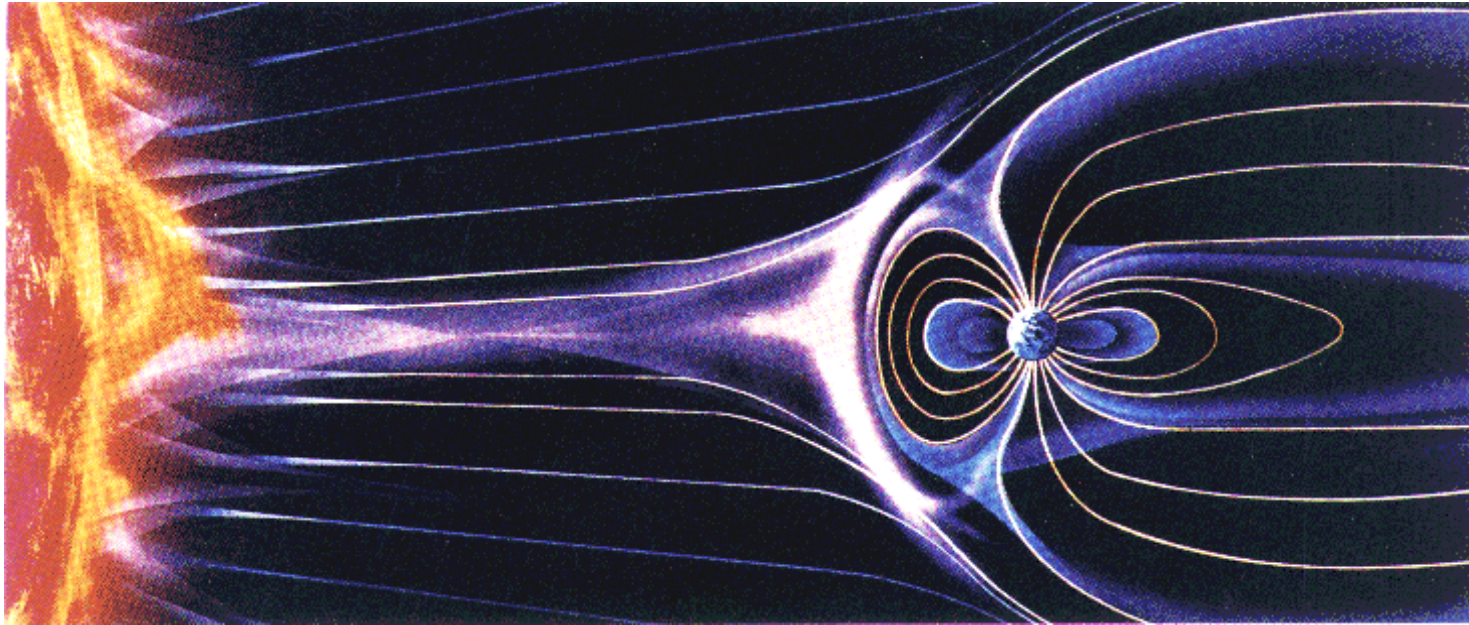

- Solar activity generates enhanced solar wind
- Interaction with magnetosphere causes substorms
- Substorms cause spacecraft charging

NASCAP Analysis Plasma Environment

- Plasma Parameters

$$n_e = 1.12 \times 10^6 \text{ m}^{-3}$$

$$T_e = 12 \text{ keV}$$

$$n_i = 2.36 \times 10^5 \text{ m}^{-3}$$

$$T_i = 29.5 \text{ keV}$$

- Orientation to the sun

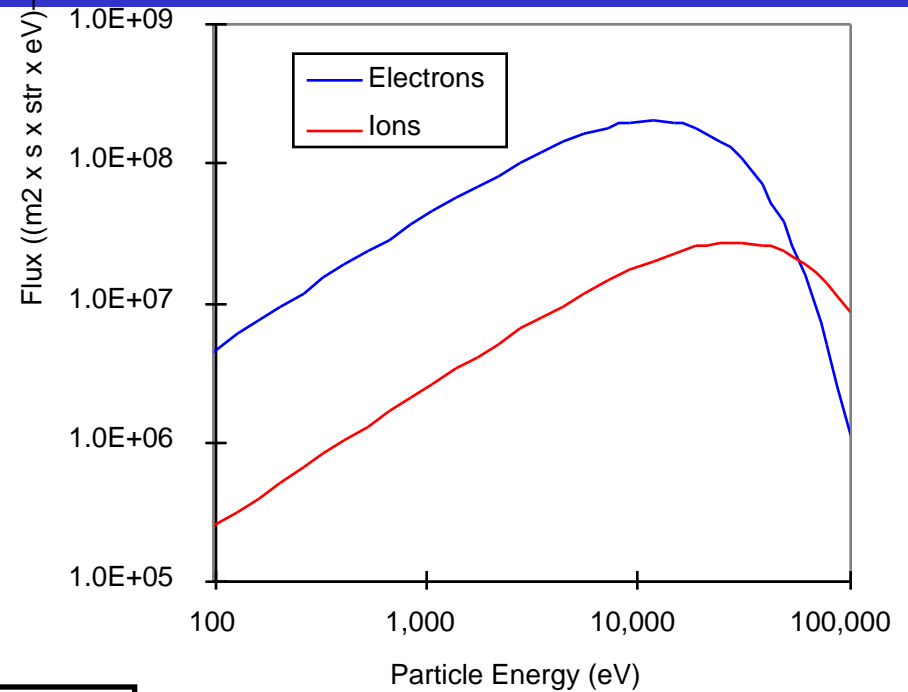
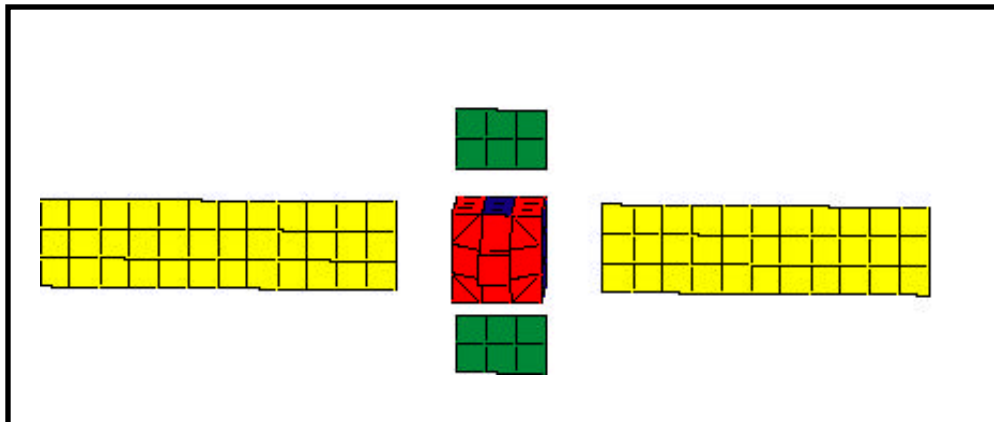

Environment from:

Design Guidelines for Assessing and Controlling Spacecraft Charging

NASA TP 2361, 1984

Spacecraft Chassis Charges in Sunlight

	Number of Cells	Average Area (m ²)	Current Density (μA m ⁻²)	Current (μA)
Shaded	97	0.72	-1.6	-112
Illuminated	33	0.69	3.4	60
Net Current				-52 μA

Simplified Initial Charging Model

- cover glass surface at space ground
- no potential barriers
- cover glass capacitance dominant
- currents to S/C chassis from conducting surfaces
- coverglass resistivity

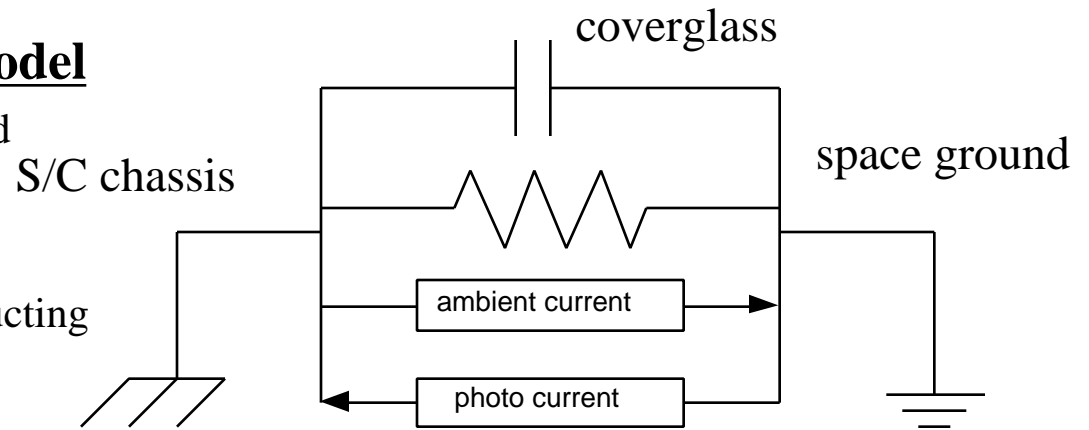

Time History of Potential Development

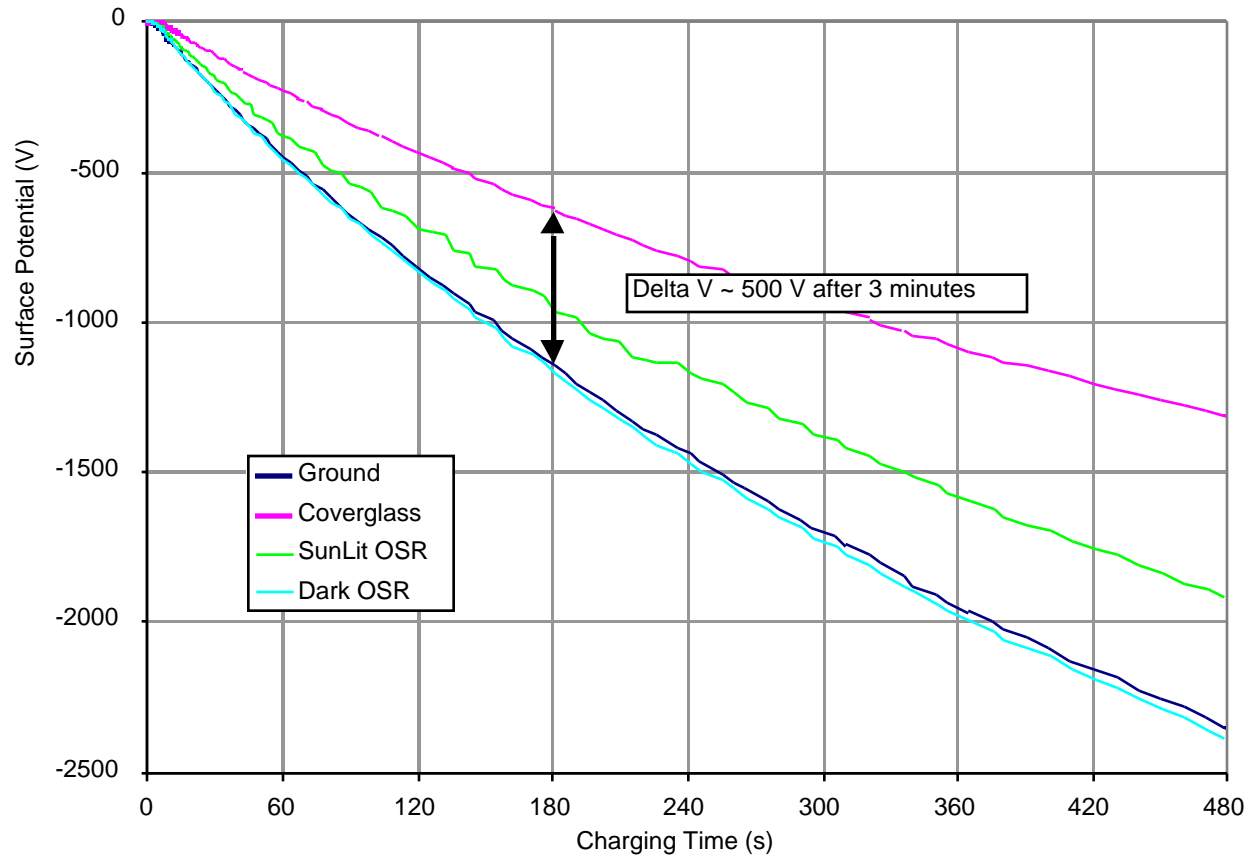

- S/C chassis charging causes solar cell coverslips to charge
- Differential charging rate $\sim 3 \text{ V/s}$

NASCAP Calculated Surface Potentials

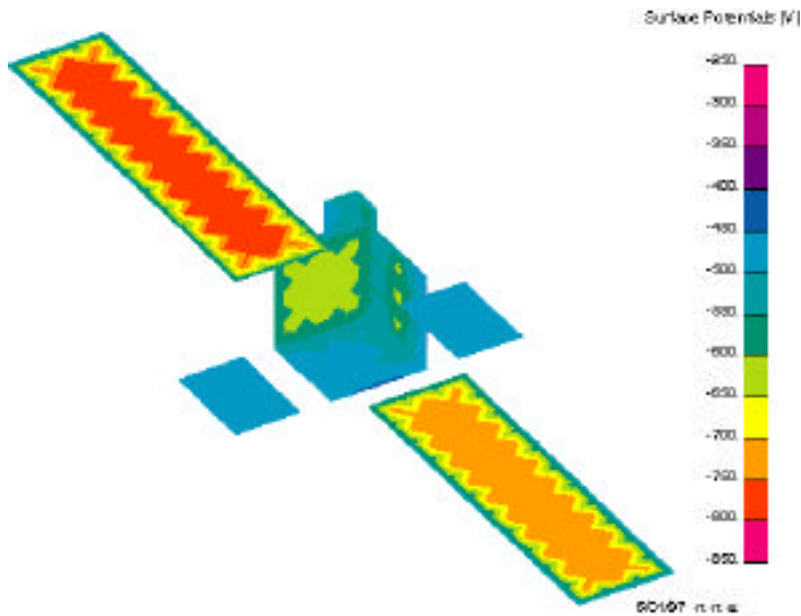

Dark surfaces develop large, negative potentials

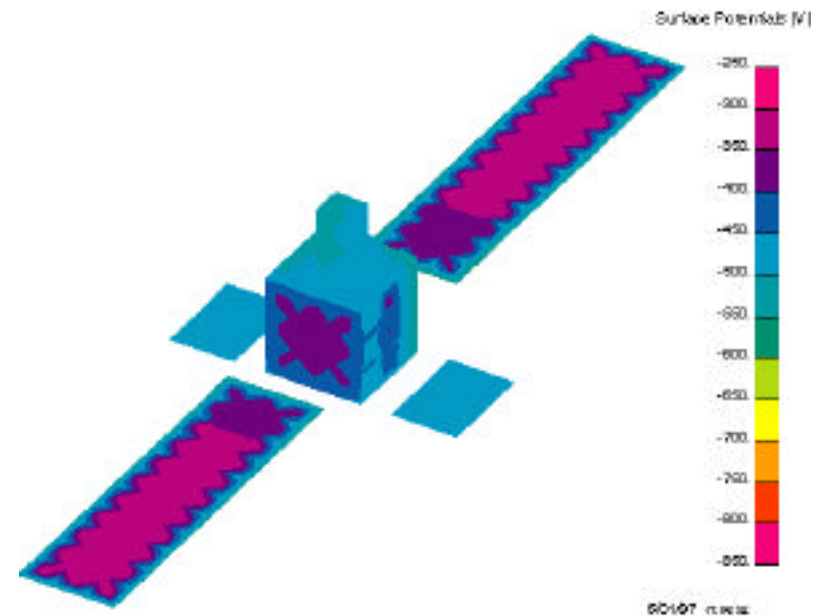

Sunlit surfaces have smaller potentials

Differential potentials smaller on inboard panels

Discharge Scenario

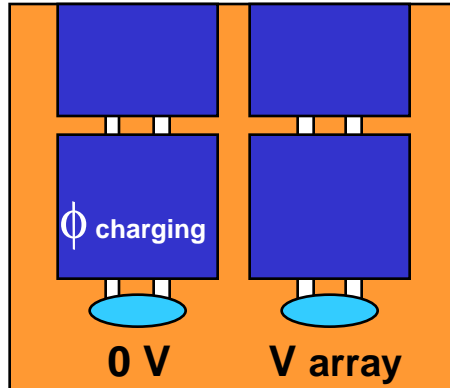

Solar Cell - Coverslip
 E field $> 4 \times 10^5$ V/m

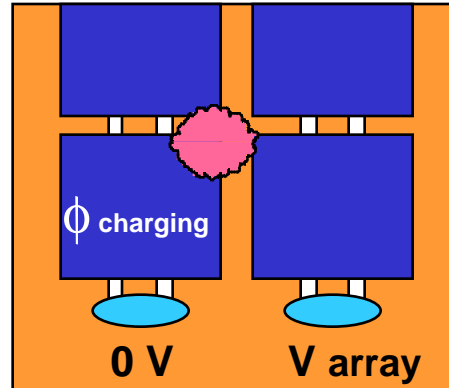

Small Discharge Starts
in Gap Between Cells
Discharge Generates
a Plasma Cloud

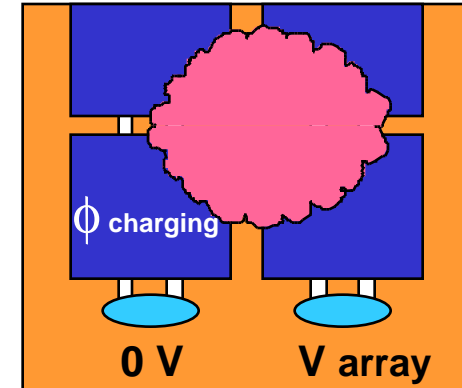

Plasma Cloud Provides
Low Impedance Path
Across String

- Spacecraft charging provides trigger arc (~ 300 V)
- Solar array string provides the power for surface flashover
- Sustained surface flashover pyrolyzes the kapton
- Permanent low impedance path across string

Design of Chamber Tests

- Goals: test if cells arc and if predicted arc currents couple to array circuit
develop same local potential structure as in GEO
test if calculated potential differences cause arrays arcing
keep chamber plasma currents negligible compared with any arc current
- Charging current densities changes charging time scale
GEO - photo electrons $\sim 1 \text{ nA/cm}^2$
Lab - Xe ions $\sim 100 \text{ nA/cm}^2$
- Lab simulates solar array gap differential potentials except near Kapton

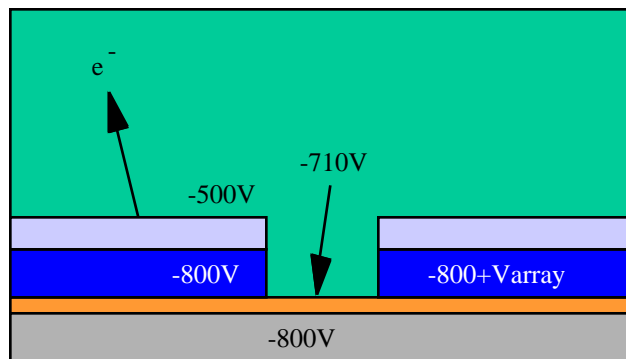

GEO

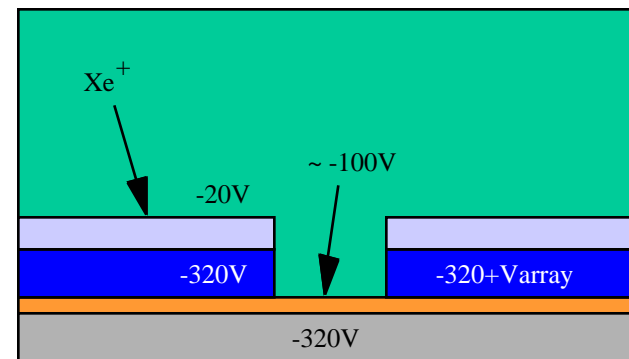

Lab

Tests at NASA/LeRC

- Chamber Environment
 - Low density, ionosphere like plasma density $\sim 10^{11} \text{ m}^{-3}$
 - Pressure $< 10^{-6}$ Torr
- Solar Array Supply (SAS)
 - Purpose: Simulate the current generation capabilities of a string
- Charging Bias Supply (CBS)
 - Purpose: Simulate the sunlight charging of the array
 - Parameters: 0 – 1000V
 - capacitor to simulate wing capacitance
 - positive terminal attached to tank ground
 - 10K Ω current limiting resistor
- Diagnostics
 - Current on the SAS supply
 - Current on the CBS supply
 - Low level TV with time stamp
 - Transient pulse monitor
- Test Procedure
 - Step from -200V to -1000V in 50V steps
 - Dwell the order of an hour at each step to allow differential to develop

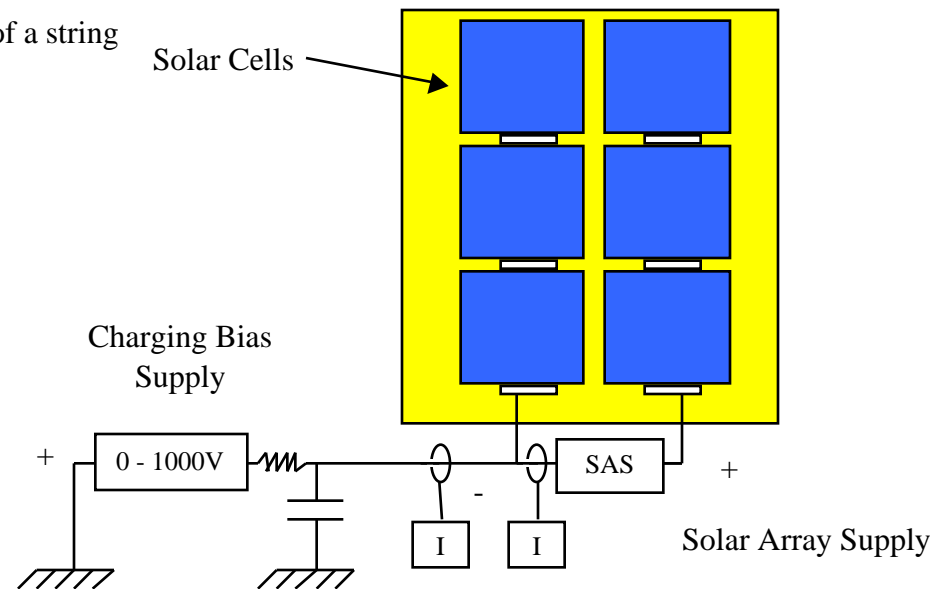

Example Test Data

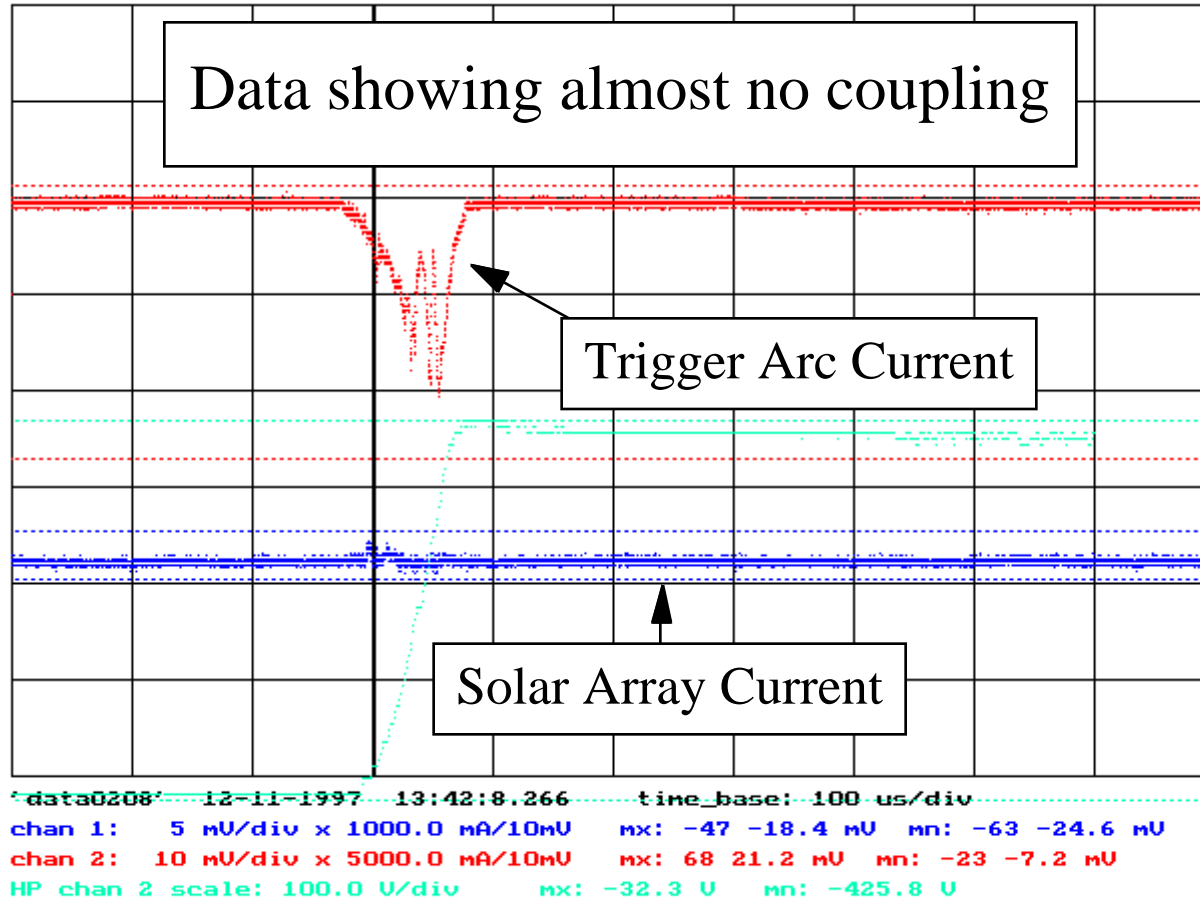

Example Test Data - Array Arc Extinguishes

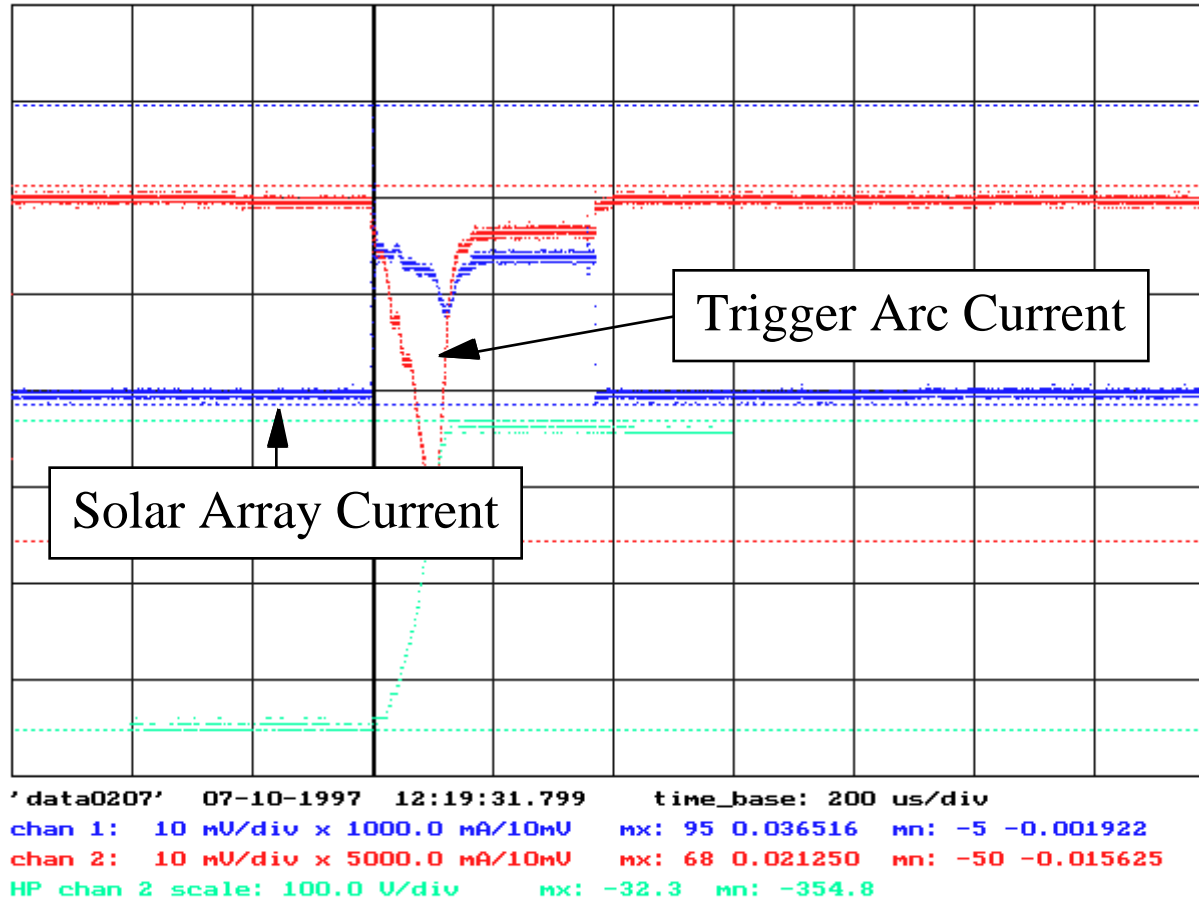

Example Test Data - Array Sustained Discharge

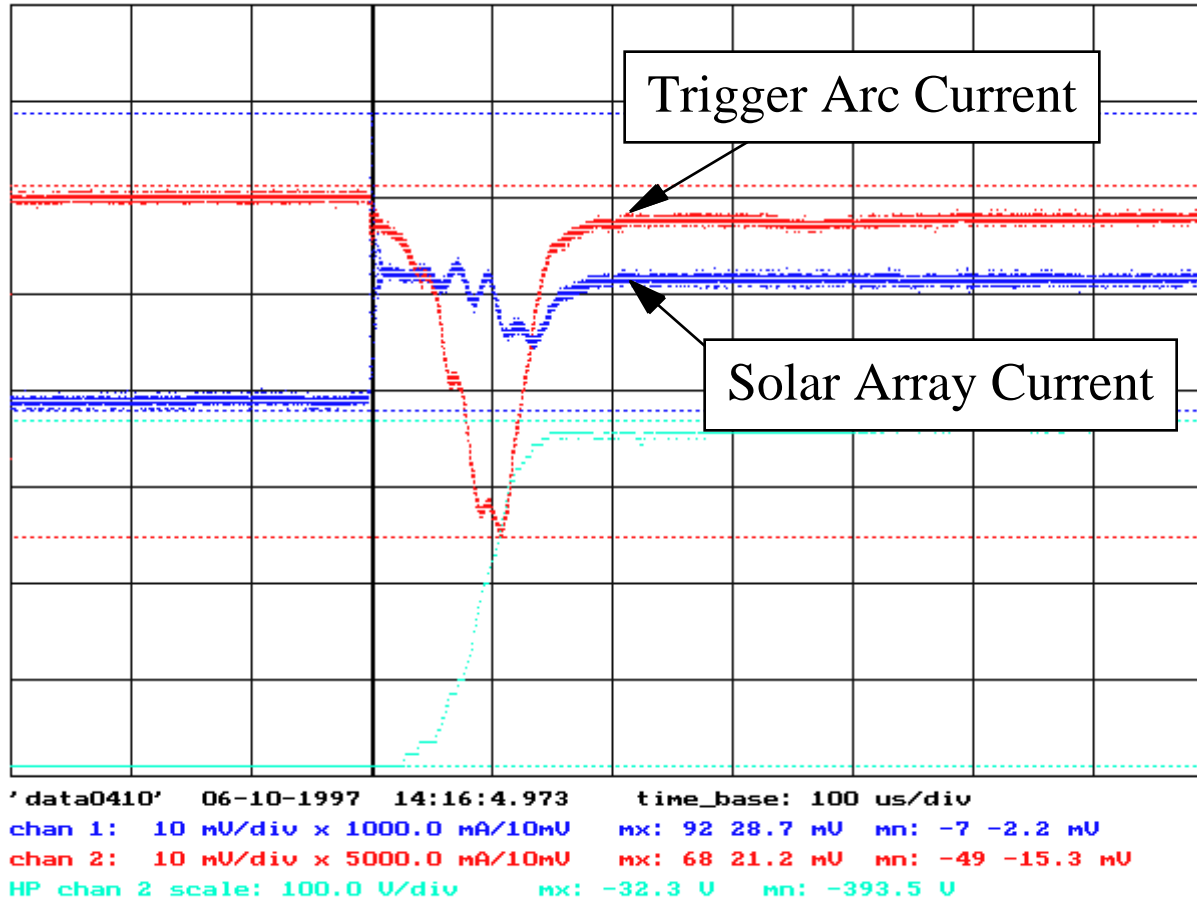



Quantitative Model Identifies Critical Parameters

- **Spacecraft Charging**
 - Ratio of dark to sunlit conducting areas
 - Environment electron temperature & density
 - Coverglass thickness & resistivity
- **Trigger Arc**
 - Panel capacitance & voltage threshold for arcing
 - Plasma generation efficiency
 - Plume expansion velocity
- **Solar Array Coupling Current**
 - Geometry
 - Potential
- **Cell to Cell Breakdown**
 - Plasma plume coupling current
 - String current
 - Cell voltage

Spacecraft Charging Sensitivity

- Environment
 - electron temperature
 - electron density
- Satellite construction
 - surface materials
 - photo emitting surfaces
- Solar cell coverglass resistivity

Resistivity	Ohm cm	1.0E+13	1.0E+14	1.0E+15	1.0E+16	1.0E+17
	Ohm m	1.0E+11	1.0E+12	1.0E+13	1.0E+14	1.0E+15
Thickness	m	1.0E-04	1.0E-04	1.0E-04	1.0E-04	1.0E-04
Resistance	Ohms m ²	1.0E+07	1.0E+08	1.0E+09	1.0E+10	1.0E+11
Current	Amp/m ²	1.0E-06	1.0E-06	1.0E-06	1.0E-06	1.0E-06
Voltage	Volts	1.0E+01	1.0E+02	1.0E+03	1.0E+04	1.0E+05

Voltage drop across a 100 μ m solar cell coverglass over the published range of resistivities.

Sensitivity of charging current to the environment

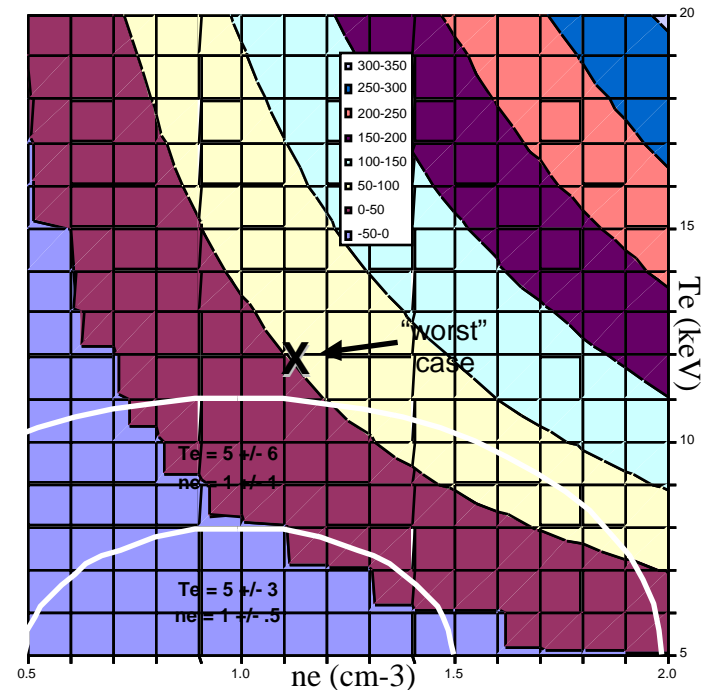

Charging current in micro Amperes

Solar Array Arc Mechanisms

- Trigger arcs are vacuum arcs
 - Fowler - Norheim pre breakdown emission
 - electric field enhanced emission (EFEE)
 - cathode spot - plasma ejection
- Plasma plume expansion
 - velocity
 - potentials
 - currents
- Anode effects
 - energy density
 - distance

Vacuum Arc Formation

- Fowler - Nordheim electron emission
 - requires local electric field enhancement
 - emission must increase field - secondary yield > 1
 - conductivity decreases field
- Cathode spot formation
 - current density
 - resistive heating
 - gas / molecular fragment release
- Quasi neutral plasma expansion
 - higher density than any orbital environment
 - similar properties for all arcs

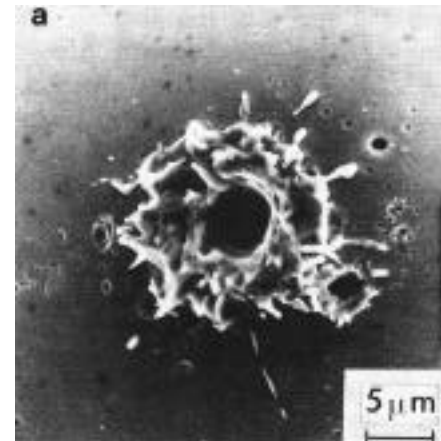

Trigger Arc Plasma Plume Model

- Arc between cell and coverglass generates a spherically expanding plasma
- Ion generation proportional to arc power
- Expansion velocity $\sim 3 \times 10^4$ m/s
- Classical electron-ion scattering
- Plasma potential from Ohm's law

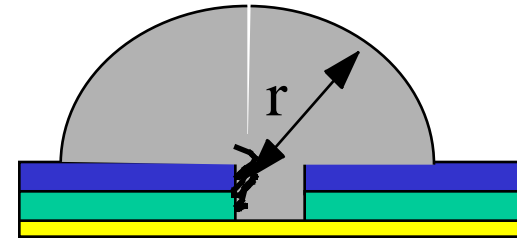

$$I_i \approx \frac{IV}{500}$$

$$n_i = \frac{I_i}{e v_i 4\pi r^2}$$

$$\sigma = \epsilon_0 \omega_p^2 / \nu_{ei}$$

$$V(r) = \int_{r_0}^r \frac{I_e}{\sigma 2\pi r^2} dr$$

Trigger Arc Cell to Cell Currents

- Plasma electron thermal current
- Cell voltage vs. plasma potential
- Sheath effects at high voltage

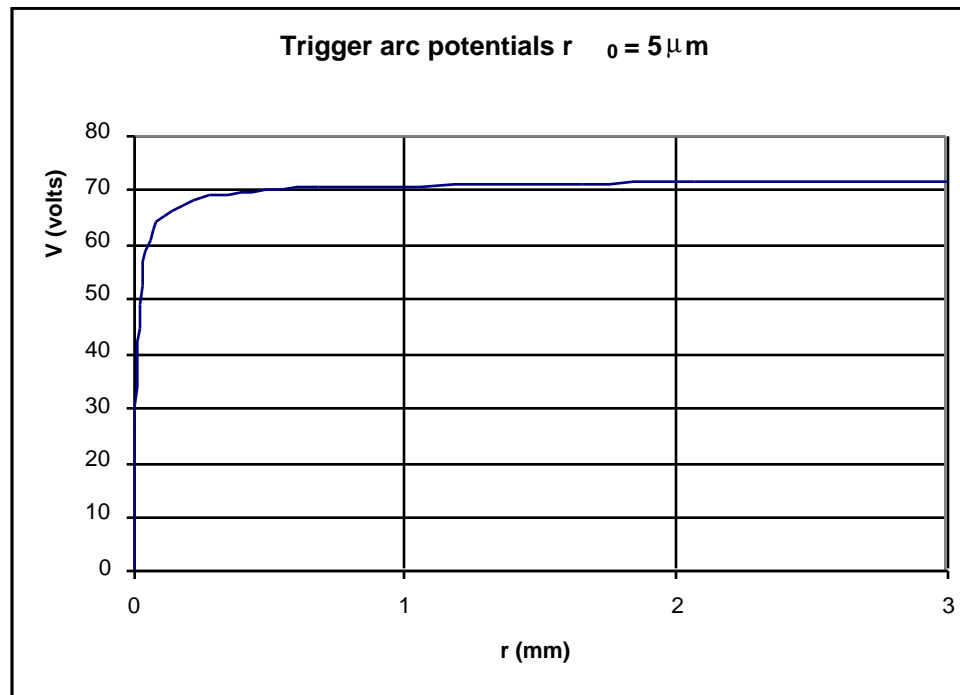
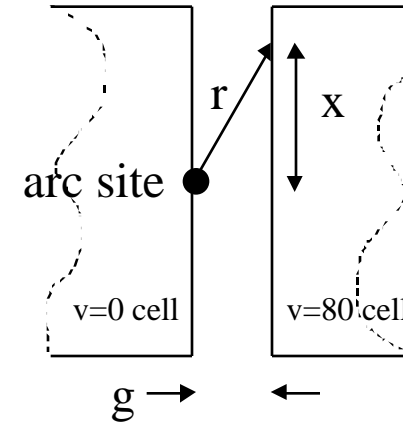

$$I_{\max} = \int_{-\infty}^{\infty} h \frac{j_e(1)}{g^2 + x^2} dx = \pi \frac{h j_e(1)}{g}$$

I_i (A)	$V(r=1\text{mm})$
0.1	127
1	99
10	72
100	44

Modifications Reduce Cell to Cell Currents

- Effect of RTV

-

-

-

- $I_{\max} = 2.6 A$

-

- Effect of lowering cell to cell potentials

$$I = \min \left(I_s, I_s \exp \left(\frac{V_b - I_a R_a}{T_e} \right) \right)$$

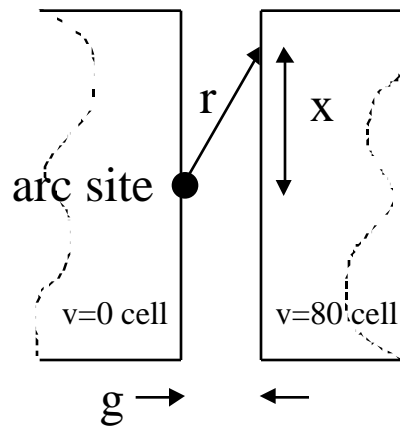

modified

$I_{\max} = 0.5 A$

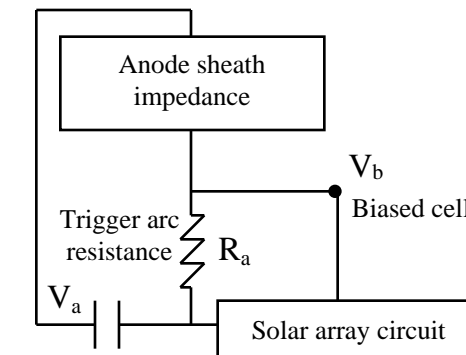
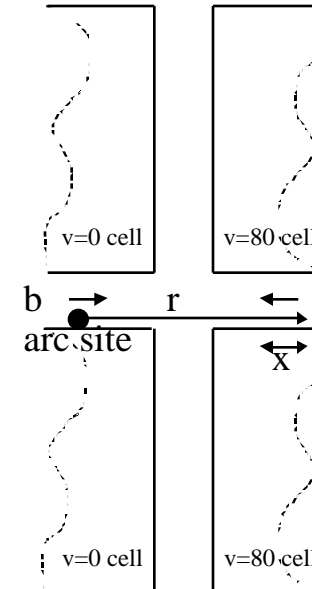

Trigger capacitance



ESD Initiated Failures on High Voltage Satellites

- Trigger arc is a classical vacuum arc
 - S/C potentials cause arcs - GEO or LEO
 - generates expanding plasma plume
 - plume density \gg orbital or lab environments
- NASA/LeRC laboratory tests support model
 - solar cells arc
 - arcs trigger array discharges
 - parameters in range of calculations
- Array modifications can stop secondary arcs
 - reduce voltage to cut both current and power to neighboring cells
 - reduce currents to below damage threshold
 - RTV in gap to decrease coupling currents

Analysis Identified Gaps in Present Knowledge

- NASCAP inadequacies
 - charging algorithm has difficulties
 - limited geometry & poor resolution
- Material properties uncertainties
 - predict too little charging
 - effect of space environment
- Solar array arc model deficiencies
 - discharge mechanisms and thresholds
 - current scaling, including array dimensions
 - coupling as a function of voltage, current, and geometry

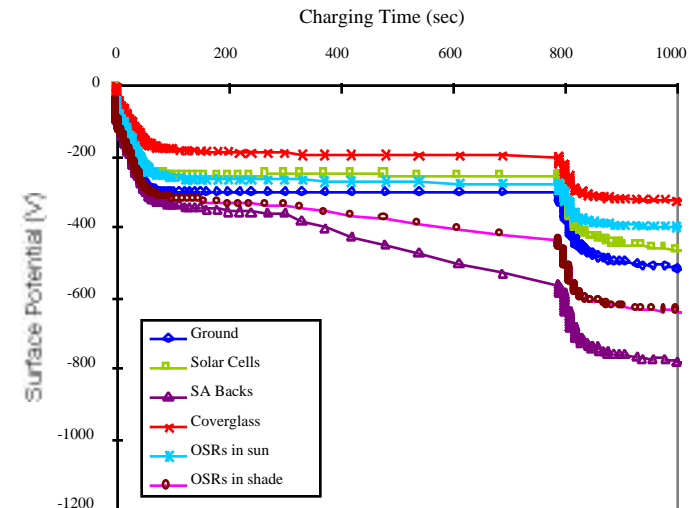

Need Laboratory Test Procedures Validated by Flight Experiment