

Chapter 11
SPECIALIZED
BLASTING
TECHNIQUES

This chapter includes information about:

- Avalanche Blasting
- 105-M 102 Howitzer
- Military Weapons
- Fireline Explosives
- Burnol Backfiring Devices
- Animal Carcass Removal
- Boulder Blasting
- Air Gapping
- Expansion Alternatives

SECTION 11A - AVALANCHE BLASTING

SECTION CONTENTS:

- Initiating Devices
- Explosive Assembly
- Use of Hand Charge
- Cornice Control
- Explosive Safety
- Recoilless Weapons - Military Weapons
- Avalauncher

AVALANCHE BLASTING

Slope testing, avalanche release, and snow stabilization are the main objectives for using explosives in avalanche blasting. To achieve these objectives, a standard charge is used that is capable of developing detonation pressure equal to 1 kg of TNT.

There are several types of explosives that can develop the appropriate detonation pressure. By knowing the detonation velocity and the density of a given explosive, the detonation pressure can be calculated (Chapter 2 - Explosives).

INITIATING DEVICES

Avalanche blasting is based on a nonelectric detonating system or systems that are not susceptible to initiation from the high static electricity that is prevalent in snowstorms and near ridge crests. Even with non-electric blasting caps, avalanche blasting should not be conducted when there is evidence of a strong static electricity field (cumulonimbus clouds, electric buzzing).

Cap-and-Fuse - A cap-and-fuse assembly can detonate explosives that are sensitive to a No. 6 cap (Figure 11-1). However, in severe winter weather, some primers with low proportions of sensitizers may require a No. 8 cap or larger. Blasting caps are susceptible to accidental ignition from excess heat, friction, or static electricity and should be handled with great care. Where adverse conditions are expected (static electricity), other techniques should be used or the blasting operation should be shut down.

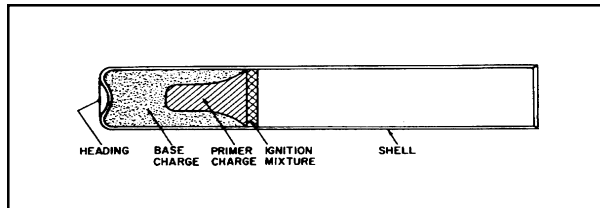

(Figure 11-1) Dupont nonelectric blasting cap.

The highest quality safety fuse should be used. The fuse length depends on the time needed to escape the blasting location. Always add a margin of safety. After a new roll of fuse is purchased, a test segment should be ignited and the burning rate should be timed. Under no circumstances should a fuse be cut to a length that allows fewer than 120 seconds burning time or less than state law allows. (Times may be greater in some states.)

Safety fuse should be stored, uncoiled, and assembled to the cap at room temperature under controlled conditions. Fuse should be cut squarely and inserted in the blasting cap immediately. A clean, square cut (Figure 11-2a) allows proper assembly. Cutting on the slant (Figure 11-2b) prevents seating. **Under no circumstances shall an ignitor be placed on the fuse until the charge is to be detonated.**

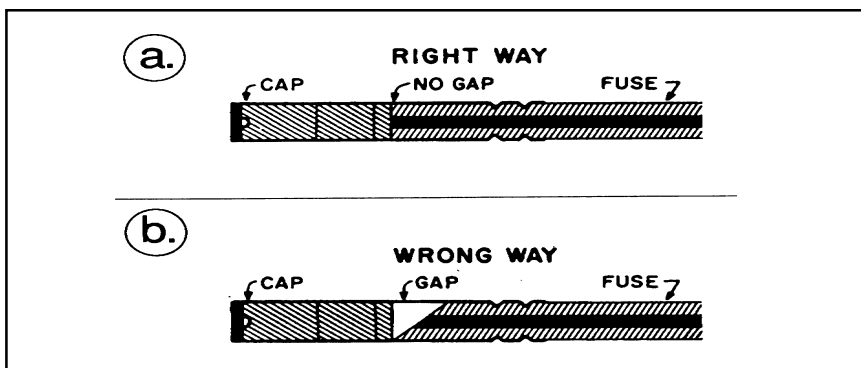

(Figure 11-2) Proper cap and fuse assembly.

Nonelectric Detonating System (Nonel) - This is a thin plastic shock tube that has a light dusting of reactive powder on the inside surface (approximately one pound per 70,000 feet). When initiated, this tube will reliably transmit a low-energy signal from one point to another by means of a shock wave phenomena much like a dust explosion. It will reliably detonate around sharp bends and through kinks. Because the detonation is sustained by such a small quantity of the reactive material, the outer surface of the tube remains intact during and after functioning. Nonel can be initiated by detonating cord or by a blasting cap. It will reliably initiate instant or delay Nonel blasting caps.

EBW (Exploding Bridgewire) - Exploding bridgewire detonators do not contain any primary explosive and are not detonated by stray currents, static electricity, radio transmission, or fire. A large, precisely timed electrical pulse from a special firing set is required to detonate an EBW. This firing set delivers the required electrical charge to the detonator through a maximum of 2500 feet of hookup wire. Three detonators, the RP-80, the RP-83, and the RP-501, may be used with this system.

EXPLOSIVE ASSEMBLY

Cast Primers - Cast primers are usually high-density, pressed, or cast cylinders of TNT, RDX, Pentolite, and/or other ingredients. They are fast, powerful explosives that are relatively insensitive to accidental detonation by shock or friction. Most were developed by the military to withstand the rigors of the battlefield. Headaches can be produced by volatilization in overheated magazines, but are caused most often by skin absorption from handling charges. One disadvantage of TNT is that it leaves a messy black crater; another disadvantage is high cost. Pure TNT is not reliably detonated by No. 6 or No. 8 blasting caps, so cast primers of TNT include a more sensitive explosive, such as PETN.

Gelatin Primers - Gelatin primers are less expensive than cast primers and do not leave a black crater. They may detonate as fast as TNT, but are slightly more bulky. They have a high percentage of nitroglycerin mixtures; they produce headaches, deteriorate, and are more shock-sensitive than cast primers. Nitroglycerin begins to freeze at -29 degrees Centigrade (-20 degrees Fahrenheit) and, if frozen, is very susceptible to premature detonation when punched. Therefore, it should not be used near this low temperature. NEVER attempt to thaw frozen dynamite by applying direct heat. Place it in a normal temperature room and allow it to gradually reach room temperature.

Two-Component Explosives - Gelatin and cast primers are classified as high explosives and must be stored and handled according to strict codes (see Chapter 3 - Storage). Because of regulations dealing with explosives security, storage is expensive. Where there is a limited need for explosives, avalanche workers may wish to avoid the more expensive storage requirements by using a two-component system. Stored separately, the components are not high explosives. They are classified as high explosives only when mixed.

The storage advantage is offset by higher cost of materials, bulkier charges, the inconvenience of mixing the explosive in the field, and the requirement of a mixing time of about one-half hour to bring the mixture to full strength. Mixing should be done at temperatures of 0 degrees Centigrade (32 degrees Fahrenheit) or above. Once mixed, the explosives will detonate at -50 degrees C or lower. When using two-component explosives where the charge will be thrown, tape the cap to the container to avoid separation and misfire.

General Considerations - As soon as the cap-and-fuse is inserted into the explosive, the system is armed. From this instant, the relatively insensitive explosive contains a sensitive cap and is vulnerable to accidental detonation. For this reason, delay arming as long as possible. Usually it is possible to arm the explosive just before tossing the charge onto the target. However, when wind and temperatures are severe, overall safety is

sometimes served by arming the explosives in a shelter before starting on the control route. Under no circumstances should the ignitor be put on the fuse until just before tossing the charge.

Arming Cast Primer - Figure 11-3 shows the steps for double arming cast primers. Most cast primers are manufactured with a hole through the middle, and an off-center hole that does not go all the way through the primer. The central hole is designed to be detonated by high-explosive detonating cord. The off-center hole is usually lined with a primer, that is sensitive to a No. 6 blasting cap. It is essential to place the cap in the proper hole to avoid a misfire. In avalanche work it is convenient to lace the fuse tightly through the central hole and then into the off-center hole, snug against the end of the hole. The assembly is then taped securely with appropriate tape.

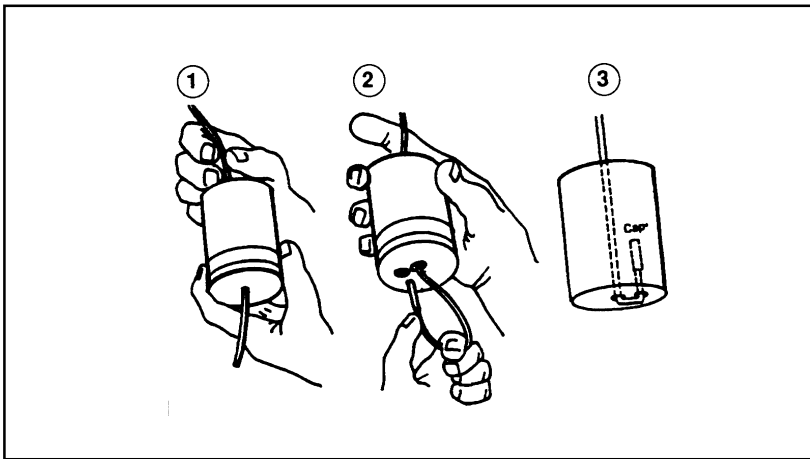

(Figure 11-3) Arming single cast primer.

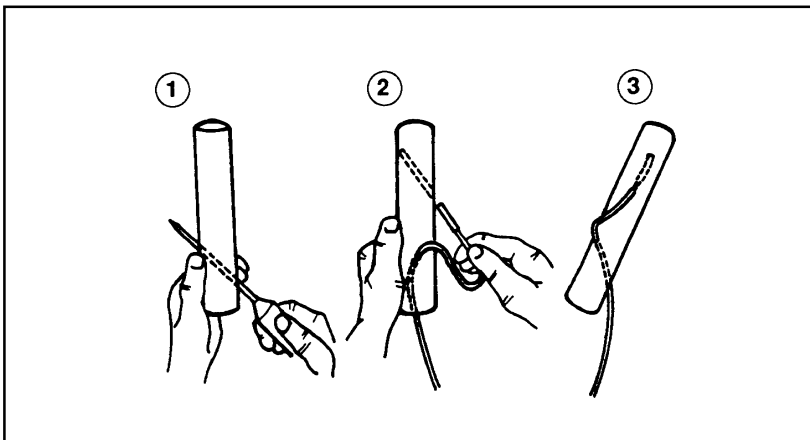

(Figure 11-4) Arming gelatin primer.

Note: The arming of two joined cast boosters is similar to the illustration in Figure 11-3 with the exception that both boosters will be capped and the fuse will pass on the outside and be considered double armed and lit simultaneously.

Arming Gelatin Primer - The arming of a gelatin primer is shown in Figure 11-4. Gelatin primers have no precast holes, so it is necessary to punch two diagonal holes. First, a hole is punched through the charge with the punch end of the crimper. Then, the charge is rotated one quarter of a turn, and a second hole is punched slightly deeper than the length of the cap. The fused cap is then laced through the first hole and the cap is inserted into the second hole. The assembly is taped securely.

Arming with Detonating Cord - Explosives may be detonated with detonating cord. Charges are armed by taping the cap to the detonating cord or joining the cap and the cord with special connectors. The explosive end of the cap should point along the detonating cord, toward the main charge. A minimum of 25 grains per foot shall be used. Consult manufacturers for proper size of cord. Because the cap is exposed and vulnerable to accidental shock in both of these systems, make the final connection of cap and detonating cord only at the blasting position when ready to fire.

USE OF HAND CHARGE

The prepared charge, including detonator, is carried in the control team member's pack. The person should not be loaded so heavily that skiing is clumsy. Ignitors are carried separately from the explosives. Team members keep in constant contact using radios. Once at the blasting position:

- a. Make sure all possible run out zones are free of people and traffic. For areas not visible from the blasting point, arrange for signals from an observer.
- b. Work with only one charge at a time.
- c. Step into blasting position and make final check of target and escape route.
- d. If not pre-armed, arm the charge.
- e. Clip approximately one inch off the end of the safety fuse and firmly insert the fuse into the ignitor. The ignitor should be activated immediately. Caution: Occasionally, the act of inserting the fuse into the ignitor may cause ignition before the ignitor is activated.
- f. Absolutely **NO RELITES**.
- g. Get to a safe position and await detonation.
- h. The charge will be held no longer than 30 seconds. The charge will be tossed and under no circumstances will there be an attempt to retrieve explosive.

APPLICATIONS FOR EXPLOSIVES IN SNOW WORK

Cornice Control

A. A simple and safe procedure for cornice blasting is to put surface charges of cast or gelatin primers, or the equivalent (ANFO) or slurries) along the estimated tension line of the cornice roof adequately.

1. Select the number of charges necessary to cover the extension line of the cornice roof adequately. Lace each charge with an 18 inch length of detonating cord, referred to a branch line.
2. Set out a trunk line of detonating cord parallel to the safe working line.
3. Set the first charge into position along the working line. Attach the branch line of the first charge to the mainline with a girth hitch, clove hitch or other approved connector.
4. In a similar manner, connect the adjacent charges on down the line until all charges are connected.
5. After connecting all branch lines to the trunkline, carefully push each charge from the working line to the presumed tension line of the cornice.
6. Align each branch line perpendicular to the trunkline.

7. Loop the end of the trunkline to form a continuous loop back to the starting point and attach the line to complete a loop.

B. A more efficient blasting scheme is to bury the charges in a row of boreholes. In borehole cornice blasting, one may achieve satisfactory results with about half the explosive used in surface blasting. It is also possible to blast effectively with low-cost, low-detonation pressure explosives, although borehole blasting of cornices increases efficiency, boring holes along the presumed tension line exposes the avalanche blaster to considerable danger. Safety in borehole blasting depends critically on:

1. The blasting crews ability to judge correctly the safe working line.

2. Feasibility of maintaining a tight secure belay.

C. The recommended steps in borehole blasting are:

1. The driller, belayed securely, steps into position on the safe side of the working line and drills a row of holes no deeper than half the thickness of the roof. Boreholes are drilled as close as possible to the cornice's potential tension line.

2. Borehole diameter should allow the charges to fit as tightly as possible. Space holes as needed. Because cornice snow is normally quite hard, boring might require an auger.

3. Once holes are bored, string out the trunkline of detonating cord. To prevent loss of explosives in the event of a sudden cornice collapse, secure a free end of the main line to an anchor until the system is ready to be detonated.

4. Insert a charge attached to the branch line into the first hole. Connect the branch line to the trunkline; refill the hole with snow, and compact it lightly.

5. After preparing all boreholes this way, make a continuous loop of the trunkline and tie it to the main turn line so all charges are inside the loop. The explosive end of the cap must point down the trunkline toward the first charge. Tie this to the main line just before igniting the charge. Firing takes place after the usual check with the posted guard.

D. Because detonating cord plays an important role in cornice blasting, become acquainted with the basic techniques for working with this high explosive (See Chapter 5 - Detonating Cord).

EXPLOSIVE SAFETY

All avalanche blasting work, including storage, transportation and handling of explosives, must comply with all laws.

A. General

1. An avalanche should not be released artificially until the avalanche path, including the potential runout zone, is cleared of people.

2. Position avalanche guards at the entrance to the path if there is any chance that people will enter the path during blasting.

3. During unstable conditions, artificial release of one avalanche may trigger sympathetic release over a wide area. Consider such possibilities and clear the appropriate area.

B. Personnel

1. Each avalanche control team shall consist of a qualified and licensed blaster and at least one trained assistant plus the required appropriate hot guards.
2. All members of the blasting team should be in good physical and mental condition and should be competent ski mountaineers. They shall all be equipped with electric transceivers and other safety gear as required (probe, ski poles, shovel).
3. All members of the blasting team shall be properly trained and qualified.
4. Responsibility for the preparation and placement of the charge shall not be divided. The blaster-in-charge is responsible for supervising all phases.

C. Explosives

4. Always handle explosives with utmost care.
1. The blasting crew must wait at least one hour before approaching any misfire. Note: Some state regulations may be longer. A misfire aflame or emitting smoke must be left alone.
2. The normal procedure is to disarm and retrieve the charge and then to escape to an avalanche-free location.
3. Deviation from the normal procedure (for example, planting a second charge next to the misfire) depends on the cause of the misfire, the sensitivity of the explosive, and the location of the charge.
4. Misfire charges which cannot be found and disposed of within 24 hours are considered abandoned explosives by law, and must be reported to both the regional blasting officer and BATF. The absolute liability associated with explosives requires that search efforts be continued until the misfire charge is located and disposed of even if that means after snowmelt. For this reason, every precaution shall be taken to prevent the occurrence of misfired charge.

E. Preparation of Detonating System

1. To prevent misfires, the detonator assembly shall be properly attached to the explosive charge.
2. Charges shall be armed with caps as late as possible in the blasting operation.

F. Firing of Charge

1. If using fuses, ignite only one fuse at a time.
2. Immediately place or throw the charge.

G. Placing Charge From Control Route

1. Place or throw the charge down onto the target from a safe position, preferably a ridge, then, retreat to a safe position.
2. In cases where the charge could slide down on a hard snow surface, it must be belayed or anchored.

H. Misfires

1. A conscientious effort must be made to detonate a misfire.
2. If conditions make it impossible to confirm detonation the slope should be guarded and closed to all access immediately. If not found, record the probable location. Record as much information as possible to aid in the detonation of the charge at a later date.
3. The blasting crew must wait at least one hour before approaching any misfire. NOTE: Some state

regulations may be longer. A misfire aflame or emitting smoke must be left along and considered a hang fire.

4. The normal procedure is to detonate the charge.

Howitzer Weapons and Ammunition

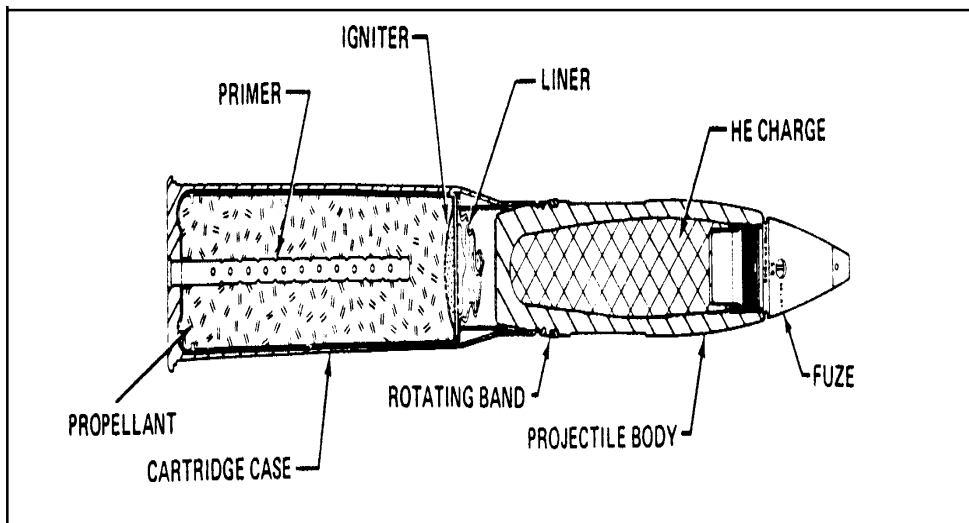

(Figure 11-5) Cartridge for 105 mm recoilless rifles used for blast, fragmentation and mining effects

Weapon

A cannon is a component of a gun, 105 Howitzer and consists of an artillery tube and a breech mechanism, firing mechanism, or base cap. Howitzer cannons are indirect fire weapons which characteristically fire projectiles with medium velocities at relatively high angles.

The M1-05-101-2 is a mobile general purpose field artillery piece. It is manually operated, single-loaded, with the firing mechanism being a continuous-pull (self-cocking) type, actuated by pulling a lanyard. The recoil is a hydropneumatic type, with a floating piston and a pneumatic respirator. The 105 Howitzer is used for either direct or indirect fire and can be elevated to high angles to deliver plunging fire on a target. The howitzer materiel can be disassembled into three major components; the howitzer, the recoil mechanism, and the carriage.

Howitzer Ammunition

When the percussion primer is struck by the firing pin of the weapon, the resulting flash ignites a small charge of black powder in the primer. The sparks and flame from the black powder ignite the propelling charge. The gases from the propelling charge drive the projectile through the bore of the weapon, where spin is imparted to the projectile by the engagement of the rotating band with the rifling bore. This spin stabilizes the projectile in flight. When the fuze functions on the target, the bursting charge detonates with both blast and

Types of Ordinance

HE: High Explosive - HE cartridges, which are made of steel and have a large bursting charge of high explosive, produce blast and fragmentation. They are used against personnel and materiel targets, and may be fitted with either a time and impact or impact fuze, according to the action desired.

HEAT: High Explosive Anti-Tank - HEAT cartridges contain a high-explosive shaped charge and are used against armored targets. They are fused with point-initiating (PI), base-detonating (BD) fuzes. When the projectile is detonated, the cone collapses, creating a high-velocity shock wave and a jet of metal particles that penetrate the target.

HEP: High-Explosive Plastic - All HEP ammunition is painted olive drab with markings in yellow. Rounds of recent manufacture have a two-inch black band encircling the projectile. Fuzes for HEP are base-detonating and require no setting. HEP is very effective against bunkers, log barricades, and similar targets. Protect unpacked rounds from sharp tools, sticks, and rocks that could puncture the propellant liner. Do not strike, drop, or handle HEP cartridges in any manner that might damage the nose of the shell body (which is easily deformed).

Howitzer Weapons And Ammunition

This M102 SOP has been adapted to avalanche control and is not all inclusive. This serves as a supplement to army technical manual TM9-10150234010, Operator's Manual for Howitzer, Light, Towed 105-mm, M102. It is not intended to be the sole source for information when deploying, firing, servicing or maintaining the weapon system, but does put terms into context for avalanche controllers to understand.

Safety must be first in everyone's mind when operating any military weapon. Howitzers do recoil and can inflict grave injury to life and limb. Moving in and around the weapon can be dangerous due to slick surface areas, exposed parts and awkwardness of handling ammunition. When considering operating/firing procedures, take into account these hazards and coordinate procedural movements and commands. Control programs differ from place to place. Deployment needs, man power requirements and locations restraints are to name a few. Because of these consideration, operating and firing procedures will differ from area to area for this weapon system.

However key safety issues have been mentioned and should be taken into account. Under no circumstances should a person be allowed to operate the Howitzer with less than the minimum amount of training that your program has deemed necessary.

All rules and regulations set forth by local, state and federal governments concerning the use, storage and movement of weapon and ammunitions must be followed at all times. Each area will be responsible for establishing acceptable firing procedures that apply to their needs, taking into account safety issues. fragmentation effect.

Projectiles

Projectiles for howitzers are steel-walled cylinders with conical, curved, or spiked noses and square bases. The interior contour of the projectile varies from model to model to accommodate different types of fuzes and high explosives fillers, at 5 bags. Set for SQ - instantaneous detonation upon impact.

Cartridge Case

Cartridge cases used with the majority of howitzer rounds are made of steel or aluminum. In some cases, a three or five piece spiral-wrapped steel case is utilized.

Propellant

The howitzer cannon ammunition, except HEAT rounds, contain Propellant M1, which is composed of a base charge, and varying numbers of increments for fire adjustment.

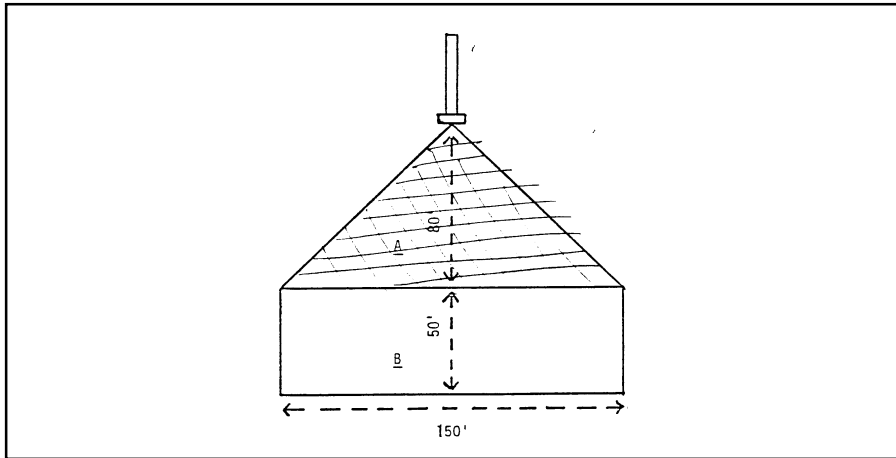

Figure 11-6) Danger Zone Diagram. In Area A there is danger of serious injury from blast and heat. In Area B there is danger from flying debris.

MILITARY WEAPONS

A. Certification for Use

1. All employees that will use military weapons must be certified every three years by the U.S. Army personnel. A regional military weapon and ammunition certification training session will be held for this. Certification is based on the results of written and oral examinations and a practical field exercise.
2. In addition, applicants must meet these requirements of the Organized Crime Control Act of 1970:
 - a. Be over 21 years of age.
 - b. Never have never been indicted or convicted for any felony crime.
 - c. Do not use unlawful drugs.
 - d. Do not use alcohol to excess.
 - e. Convicted for violating laws of domestic violence
3. The written examination covers the safety of weapon use and the handling, transporting, and storage of ammunition.
4. In the oral examination, the applicant must demonstrate an overall understanding of safety rules for military weapons, firing techniques and principles.

5. Applicants must demonstrate in a field exercise, or in a mock field exercise, the ability to handle ammunition and to set the ammunition for loading, aiming, and firing. They must demonstrate actions to take in the event of a misfire, cook-off, and a dud.
6. From the results of the written examination, the oral examination, and the field exercise, or US army personnel examiner or a designee determines if the candidate is fully qualified. Applicants not fully qualified, but who have not been eliminated, will be placed in an in-training category until experience and skills have been obtained. They will then be reexamined for certification. The in-training category is gained only through the certification process.
7. Certificates must be renewed every three years. Renewal will be under the same conditions as the issuance of the original certificate. A yearly refresher course shall be given to all personnel who use military weapons.
9. Certificates can be suspended at any time by the NPS, or upon the recommendation of the US Army examiner. Suspensions will be made when safety violations have occurred or when evidence exists that there is a lack of skill. To regain certification, a suspended employee must pass the exams and field exercise and be recertified by the US Army Certified Personnel and reviewed by the Regional Blasting Officer.
10. Each Park shall have a Standard Operating Procedure (SOP). This SOP shall be reviewed by the regional examiner and approved by the US Army authorities.

NOTE: Under no circumstances (in the case of a dud/non detonated round) shall NPS employees undertake disposal activity. Only experienced Army personnel trained in ordnance disposal shall undertake this hazardous task.

B. Military Ammunition Storage

1. Military ammunition storage facilities shall be fireproof, weatherproof, bulletproof, and theft-resistant. All above ground facilities must be constructed to conform with the requirements for lightning protection found in the current edition of the National Fire Protection Association Standard No. 78.
2. Ammunition may be stored in approved magazines cordwood style (that is, piled so they touch each other in their original cardboard tube or other type of original packing cover) only. The minimum distance from the magazine to inhabited buildings, highways, ski lifts, and designated ski runs is 1200 feet for 105 mm and 106 mm ammunition. These minimum distances provide reasonable protection from flying fragments (See Chapter 3 - Storage).
3. Above ground storage:
 - a. Magazine storage buildings for ammunition only must meet the minimum requirements as de-

scribed in ATF Explosive Laws and Regulations (ATF p. 5400.7) dated 10/91 or the latest edition, subpart K-Storage, section 55.207 with the following exceptions:

- 1) The interior of the magazine does not need to be constructed of a non-sparking material.
 - 2) Only outdoor facilities shall be used, all doors shall be constructed of 3/8-inch steel plate and lined on the inside with two inches of hardwood.
- b. Ammunition may be stored above ground at less than 800 and 1200 feet from inhabited buildings, highways, ski lifts, and designated runs if facilities are designated to resist mass detonation and to provide directional control of blast and fragments.
- c. For magazines with 12-inch thick, reinforced concrete walls and roof, or with three feet of earth cover against the walls and with the access door in the roof, the following apply:

	Minimum Round Separation Inches	Fragment Hazard Distance Feet
105mm	4.00	60
105mm	4.75	60

(Figure 11-7)

- d. The minimum round separation may be provided by a *winerack* fabricated from concrete or concrete pipe or from tubing with sand as a separating medium. Materials other than these may be used for winerack construction, providing they have been approved by and have been tested to the satisfaction of the NPS. The cost of such testing is the responsibility of the permittee. Cardboard tubes shall be completely contained within the winerack except that the primer end may stick out approximately one inch for ease in removing the tube from the winerack.
- e. Where magazine access doors are in the sidewalls, 1200 feet must be used as a fragment hazard distance in the direction the door faces for 105 mm ammunition. This distance is necessary, unless barricades or other means reduce the fragment hazard distance. Directional control of air-blast and fragments can be achieved by designing a weak wall or roof (usually by placement of the access door) or by strengthening the walls with earth.
- f. Location and design of the storage facility must consider the fragment hazard distance and the potential damage from the air blast of an explosion.
- g. When the access door is in the roof, fragments are projected through this weak point in the roof and fall back to earth close by, while fragments projected through a sidewall access door travel a greater distance because of horizontal velocity.
- h. The following thicknesses of cover or embankment are considered adequate to provide protection against fragment throw (this criteria should be used in areas where fragment throw cannot be permitted in certain directions):

4. Underground Storage:

- a. Ammunition may be stored underground, cordwood style, at less than 800 feet (75 mm) and 1200 feet (105 mm) minimum distance, if the appropriate formulas are used to determine the depth of cover required as protection against fragment throw.
- b. HEP-T ammunition has an explosive filler of Comp A3 and the filler weight must be multiplied by a factor of 1.35 to obtain the equivalent TNT filler weight. The explosive filler weight W is the sum of the weights of filler in the total number of rounds to be stored in the facility.
- c. The depth of overburden arrived at by using these formulas is considered adequate against debris throw, except in the direction in which the explosion is vented. The blast areas must be clear of buildings, highways, roads, ski lifts, designated ski runs, and other inhabited facilities for 800 feet for 75 mm, and 1200 feet for 105 mm ammunition. This cover should be used in areas where debris throw cannot be allowed in certain directions.
- d. The minimum distance from tram towers, terminals, ski lift towers, inhabited buildings, and other items that could be damaged by shock waves or air blast from an explosion must be considered on an individual basis. Minimum distances shall be determined as described in the interim change to DOD 6055.9, Chapter 9, "Quality-Distance Standards for Underground Storage."
- e. Tables 11-4 gives the number of rounds, total pounds of explosives, and amount of cover required to eliminate debris throw for various ammunition using hard rock or earth cover. This is adequate to eliminate debris throw, except in the direction of the access door.

	Earth Cover Feet	Hard Rock or Concrete Feet
105 mm M-323 HE	5.80	4.75
105 mm M-326 HEP-T	7.50	6.0

(Figure 11-8)

C. Weapon Security. Discourage theft of avalanche control weapons by:

- 1. Removing vent assembly, firing pin from firing control sight, breech, or similar part of the weapon after firing sequence and storing in the ammunition storage magazine or other similar locked facility.
- 2. Removing guns from firing stand and storing in secure facility at the end of the avalanche season.
- 3. Securing weapon to mount during firing season.

AVALAUNCHER

A. Assembly of Rounds

- 1. Gather the necessary components to assemble enough rounds for mission (primers, caps, nose cones).
- 2. Round preparation should be done in a controlled environment.

3. Prior to assembly, count out an equal number of powder bags @5, and nose cones.
4. Round assembly.
 - a. Inspect primer for correct cap well depth, diameter and for pieces of pentolite in cap well.
 - b. Inspect fin assembly making sure all parts are present.
- c. Inspect nose cone of primer for proper setting.
- d. If assembly rounds are transported, do so with caution. Prior to transport, package rounds so they remain in a stable position.

B. Tower Procedure

1. Clear tower of snow and inspect all equipment.
2. Check range of swivel on avalauncher and adjust braking mechanism used for locking swivel.
3. Quickly release valve on nitrogen bottle to be used and expel a quick blast of gas to ensure a clear opening free of foreign matter. Check threads on bottle for ice.
4. Inspect male gas hose coupling for ice and other obstructions.
5. Prime vessel until flagger valve closes:
 - a. Check barrel for ice and assemble into loading tray.
 - b. Check that “match marks” on barrel are in correct position in relation to loading tray.
 - c. Check vessel for gas leaks. If there is a leak, do not fire the avalauncher until the leak has been fixed.
6. Test fire unloaded avalauncher at 50 psi.

C. Loading

1. Keep number of personnel and ammunition in the area to a minimum.
 - a. Single gunner missions are permissible. However, all steps in this procedure shall be followed.
2. Loading:
 - a. Done in “horizontal position” or at “elevation position.”
 - b. Check that safety valve is in the “on” position.
 - c. Prime vessel until flapper valve closes (50 lb standard).
 - d. Site avalauncher to proper deflection for desired shot.
 - e. Slide barrel out of loading tray and lock in position for loading.
 - f. Visually inspect that projectile is properly assembled. Place the round in the loading tray, making sure it is properly seated. Remove the cotter pin for the assembly and retain so as to keep track of rounds fired.
 - g. Slide barrel down into loading tray. Check that “match marks” on barrel are in correct position in relation to loading tray

105 mm M-326 HEP-T
7.5 lbs. Comp A3

No. of Rounds	TNT Lb	Hard Rock Ft	Earth Cover Ft
100	1,010	23.90	34.32
200	2,020	29.43	43.14
300	3,030	33.23	49.31
400	4,040	36.23	54.22
500	5,050	38.74	58.37
600	6,060	40.91	61.98
700	7,070	42.85	65.22
800	8,080	44.60	68.16
900	9,090	46.21	70.86
1,000	10,100	47.69	73.37

(Figure 11-9)

D. Firing

1. A “safe” first shot (i.e., registered round) must be fired on each mission to indicate if there is any variance in normal weapon behavior.
 - a. Shot pressure should be kept above 65 psi to ensure the removal of base plate/arming pin by air friction as round leaves the barrel.
 - b. For firing missions involving new platforms, new terrain or new targets, gunners should gather data by aiming low and gradually work shots into desired location.
2. Firing
 - a. Raise avalauncher to proper elevation if applicable.
 - b. Fill pressure vessel to desired pressure and double check pressure with data.
 - c. Recheck deflection and elevation.
 - d. Gunner calls out “All Clear.”
 - e. Gunner calls out “Ready to Fire.”
 - f. Release safety valve.
 - g. Gunner calls out “Fire.”
 - h. Gunner presses trigger valve down to fire.
 - i. Gunner observes projectile flight to observe discrepancies in trajectory and point of impact in case of dud.
 - j. Close trigger and safety valve.
 - k. Prime pressure valve until flapper valve closes (50 lbs).
3. Post firing mission record:
 - a. Date and time.
 - b. Who fired the avalauncher.
 - c. Shot numbers fired upon, pressure, elevation and results.
 - d. Wind and temperature.
 - e. Record all duds and any probable causes.
 - f. Any additional comments pertinent to mission, i.e., maintenance needs, round flights, etc.
4. Projectiles with fuses shall not be retrieved but destroyed in place.

Section 11B - FIRELINE EXPLOSIVES

Section Contents:

- Fireline Explosives (**Note: fireline certification is provided by US Forest Service Examiners only**)
- EBW Detonator and Firing Set
- Procedures
- Burnol Backfiring Devices
- Animal Carcass Removal
- Boulder Blasting
- Air Gapping
- Expansion Alternatives

GENERAL

Fireline explosives are linear explosives that enable crews to construct firelines under certain conditions much faster and with less environmental impact than conventional methods. The quality of line constructed varies from a nearly finished line in light brush or grass fuels, to a lower quality line than required in heavy brush

and slash fuel types. However, even in heavy brush and slash, the cleaning action of explosives can enhance access for and the effectiveness of fire crews who finish the line.

All fireline explosives are tested by the Bureau of Mines to ensure that they will not accidentally detonate under field conditions. They are impact tested to ensure that they will not detonate when paracargoed, even if the parachute fails to deploy. They will not detonate when shot with a 30-caliber projectile, and they will not mass detonate if accidentally caught on fire. Only those fireline explosives that pass the tests, and that are accepted on the qualified products list, can be used for this activity. In conjunction with fireline explosives, the exploding bridgewire detonator (EBW) system is exclusively used to ensure the safest system for building firelines.

ADVANTAGES OF FIRELINE EXPLOSIVES

As labor and overhead costs rise, fireline blasting offers significant time savings. Smaller crews may be used to suppress fires because less cutting and/or digging handline is required, particularly in heavy fuels or ground cover. Increased speed of building the line can save wildland resources. Sometimes smaller crews equipped with explosives can be delivered to a fire faster than larger, conventionally equipped crews.

Other advantages include:

- Brush and other debris (fuel and slash) are scattered rather than piled next to the finished line.
- Mineral soil in the line is loosened and easy to dig for use in hot-spotting; a fine layer of soil dusts fuels close to the line and acts as a retardant.
- Blasting is generally more environmentally sound than using hand tools or dozers.
- Fireline explosives can be paracargoed into extremely remote locations.

DISADVANTAGES OF EXPLOSIVES

Use of explosives for fuels management or wildfire projects can be limited by lack of adequate explosive storage facilities. Personnel using fireline explosives must be carefully selected, thoroughly trained, and specifically licensed for this activity. Transportation and handling demand special precautions.

FIRELINE EXPLOSIVES

Fireline explosives are typically a minimum of 50 to 70 feet long, range from 1 1/4 inch to 1 1/2 inch in diameter, and weigh about 60 to 70 pounds when supplied in a cardboard box. Fireline explosives are made and sold as follows:

- PETN explosive cord supplied by Ensign-Bickford.
- Water gel supplied by IRECO or ETI Companies.
- Emulsion supplied by Austin Companies.

Note: PETN explosive cord is typically rigid compared to water gel and emulsion and does not conform to the ground very well. The latter two explosives are very flexible. No end connectors are provided on any of the explosives, so ends are taped (attached) together to ensure propagation from one length to the next.

Note that all fireline explosives are Class A explosives.

PETN Explosive Cord

PETN cord detonates at about 21,000 feet per second at temperatures well below 0 degrees Fahrenheit.

Both versions of the explosive cord come packaged in a fiberboard box measuring 20 3/4 inches by 21 1/2 inches by 12 inches. Each box contains approximately 100 feet of the seven-strand cord, which weighs about 71 pounds, or 175 feet of the four-strand cord, which weighs about 70 pounds.

PETN has an indefinite shelf life.

Water Gel Explosives

Water gel explosives are a slurry type explosive packaged in 50-foot or longer plastic tubes and are supplied on cardboard reels (Figure 11-8).

Water gel explosives consist of oxidizing salts, fuels, and sensitizers dissolved or dispersed in a continuous liquid phase. The entire system is thickened and made water-resistant by the addition of gellants and cross-linking agents. The oxidizing salts are usually selected from ammonium nitrate or calcium nitrate. Aluminum, gilsonite, and oil are frequently used as fuels. Sensitization may be provided by chemical sensitizers such as the nitrate salts of organic amines, nitrate esters of alcohol, perchlorate salts, or small particles of aluminum. Physical sensitization may be provided by entrapped air bubbles, either alone or in combination with chemical sensitizers. Water gels are Class A explosives that detonate at a speed of from 15,000 to 18,000 feet per second. Water gels will not detonate consistently at temperatures below 40 degrees Fahrenheit.

The shelf life of water-gel is about one year although some manufacturers report shelf life as high as five years.

Firing Module

The firing module (Figure 11-12) is separated from the control unit so the operator can detonate the charge at extended distances (500 feet) as required by the size and characteristics of the main explosive charge.

The input to the FS-9 module must be between 32 and 40 volts. This input charges a one microfarad capacitor. When this energy storage capacitor reaches 3000 volts, it is discharged across the "To EBW Detonator Only" terminals of the firing module. By mating the shorting plug to the "Discharge" connection, the energy storage capacitor is completely and immediately discharged, thus precluding inadvertent arming of the firing module and detonation of the EBW detonator. The firing module consists of a completely sealed metal box which includes:

- a. Binding posts for connecting the input wires from the control unit.
- b. A voltage conversion system to increase the input voltage to approximately 3000 volts to insure proper function of the EBW detonator.
- c. An automatic trigger system that discharges when the module contains sufficient energy to fire the detonator (3000 volts, 1500 Amps).
- d. An internal discharge capability if a misfire or abort should result.
- e. An external shorting capability across the energy storage capacitor by using the same connector or shorting plug as used at the control unit "Safety Interlock" connection.
- f. Binding posts for connecting the output wires to the detonator.

Lead Wire

Duplex strand solid core 18- or 20-gauge wires are used as primary and secondary lead wires. The secondary lead wire is a minimum of 500 feet long and a maximum of 2500 feet long. The primary lead wire is a maximum of 100 feet long. The wire should have a slick, tough insulating coat.

PROCEDURES

Communications

The blaster-in-charge will plan communications with a designated blasting team regarding:

- Safety.
- Layout and firing procedures.
- Location of guards and/or flaggers.
- Length of explosive that can be safely guarded and controlled.

The blasting team should have a clear radio channel while in actual operations. Each team member should have a radio. The blaster-in-charge must brief the team to ensure good communications. Some suggested points to be covered are:

1. Packers (packers are also typically guards):
 - a. Discuss various methods of explosive deployment.
 - b. Do not throw boxes of fireline explosives or handle roughly.
 - c. Prior to blasting and hookup of each fireline segment to be blasted, a final check on deployment will be made by the blaster-in-charge or the assistant blaster.
2. Guards (typically also packers):
 - a. Assign each guard a number (guard #1, guard #2).
 - b. Indicate where each guard is to be located and be sure he or she knows the location (minimum of 500 feet from firing line) (See Figures 11-13 and 11-14).
 - c. Cover radio and/or verbal communication techniques that will be used, including the number each guard uses.
 - d. Guards should have a good vantage point for observing and listening around the blasting area.

Emulsions

Emulsions are packaged in plastic tubes, however, they are not typically supplied on reels.

Emulsions are the first commercial explosive manufactured with all liquid oxidizers and liquid fuels. The liquid oxidizers are dispersed as microscopic droplets in the liquid fuel. The result is a very intimate mixture of these components, leading to a vastly improved “intimate reaction zone” and a more complete and efficient reaction.

With most emulsion formulations, there is very little change in their viscosity at ambient temperatures down to 10 degrees Fahrenheit, and they will typically detonate at temperatures down to 0 degrees Fahrenheit. They do thin out at temperatures above 100 degrees Fahrenheit.

The shelf life and stability of emulsion explosives is excellent with no change in their explosive properties after one year. (Storage time can exceed two years.) Emulsions are a Class A explosive that detonates at a speed of about 15,000 to 18,000 feet per second.

Safety Tests

The seven-strand fireline cord was originally tested by the Naval Weapons Center at China Lake, California. The cord was subjected to bullet impact, burning, crushing between caterpillar tread and rocks, chopping with an ax on rock, dragging over rough ground, air dropping 500 to 1000 feet, bending, and exposure to retardant—all with no indication of possible hazard. Note, however, that even though safety tests indicate that the cord can be burned, etc., without detonating, there is no guarantee that detonation will not occur.

Water gels and slurries include both cap sensitive and non-cap-sensitive products. A significant advantage of water gels is that they are reliably sensitive to conventional priming methods, yet significantly more resistant to accidental detonation from abusive impact, shock or fire. When subjected to an open flame, water gels will burn but not detonate. In a test conducted by the Canadian Government, an enclosed truck containing five tons of water gel did not detonate when burned. Water gels will not detonate when shot with a 30.06 projectile. Users should, however, recognize that water gels are explosives, and should be treated as such. While specific tests indicate that water gels are relatively safe, severe shocks, such as higher velocity bullets can detonate these products.

Fireline emulsions do not utilize explosive sensitizers, and in reality do not become an explosive until after the addition of “micro-balloons” or air voids. For this reason, emulsions are perhaps the safest explosive, other than water gels, in terms of flame, impact, and friction resistance. Emulsions fail to detonate from impact and friction tests used as the standard throughout the industry, including the bullet impact test. Independent studies done to determine at what severe conditions explosives will detonate, clearly show emulsions have a higher degree of resistance to detonation from impact than either slurries or dynamites. However, emulsions are explosives that are designed to detonate. The relatively safe emulsions demand respect and the proper handling requirements afforded to all explosives.

Safety testing of all approved fireline explosives is conducted by the Bureau of Mines, Safety Testing Laboratory, Pittsburgh, Pennsylvania. These tests are designed to show that approved fireline explosives meet or exceed the safety characteristics of the seven-strand PETN cord.

EBW DETONATOR AND FIRING SET

The FS-9 Exploding Bridgewire (EBW) firing system (Figure 11-9) is designed to generate and deliver an electrical energy pulse to reliably fire exploding bridgewire detonators. Electric blasting caps (EBC) are not used with this system. The FS-9 EBW firing system is to be used exclusively with fireline explosives.

EBW Detonator

The EBW detonator (Figure 11-10) is an alternative to the common electric blasting cap. While similar in construction, the EBW detonator is characterized by the exclusive use of secondary explosives that will not detonate when exposed to heat, friction, fire, static electricity, low voltages, or radio transmission. EBW detonators are rated “Class C” explosives and have less restrictive shipping regulations than conventional blasting caps. EBWs, however, are required to be stored in the same way as conventional caps.

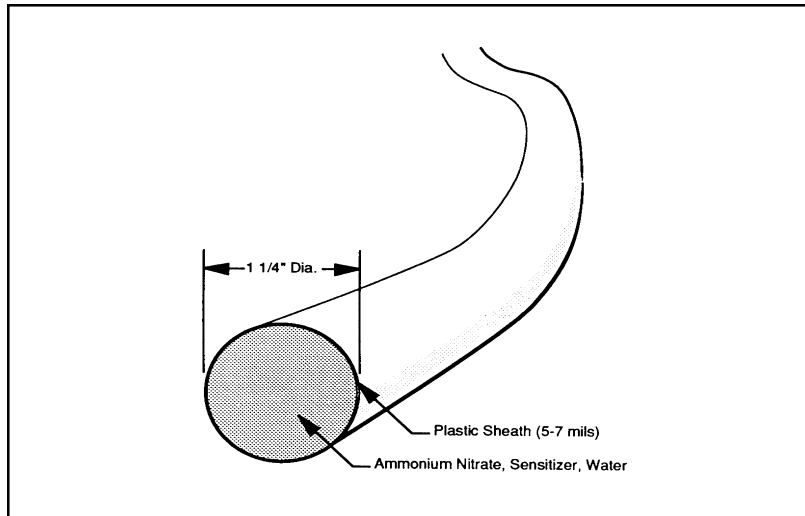

(Figure 11-8) Construction of a typical water gel explosive tube..

The purpose of the FS-9 control unit (Figure 11-11) is to provide low voltage (40 volts DC) electrical energy to the firing module and to ensure a safe and reliable operation sequence for the firing of the EBW detonators.

This output occurs when both the “Hold-to-Arm” and “Hold-to-Fire” buttons are simultaneously pressed and the shunting plug is mated into the control unit “Safety Interlock” connection. The “Battery OK” lamp will illuminate when the “Hold-to-Arm” button is pressed, only if the batteries are above 32 volts. When the “Hold-to-Fire” button is pressed in conjunction with the “Hold-to-Arm” button, the voltage is then applied to the output terminals and the ready lamp will illuminate. At this time, the firing module, if connected, will begin arming and automatically fire within two to eight seconds. To abort the firing while arming is taking place, merely release the “Hold-to-Arm” or “Hold-to-Fire” or both buttons before detonation occurs.

The FS-9 control unit consists of the following items:

- A shorting plug that precludes arming of the system until mated to the control unit “Safety Interlock” connection.
- Dual pushbutton or toggle switches for firing.
- Ready-to-fire lamp indicator.
- Internal batteries for supplying the electrical energy.
- A battery charger that operates from 110 volts AC line voltage.
- A battery check lamp allowing verification of adequately charged batteries.
- A sealed case for carrying and transporting the firing system.
- Fuse to protect the system circuitry.
- Wire screw plugs for wire connection.

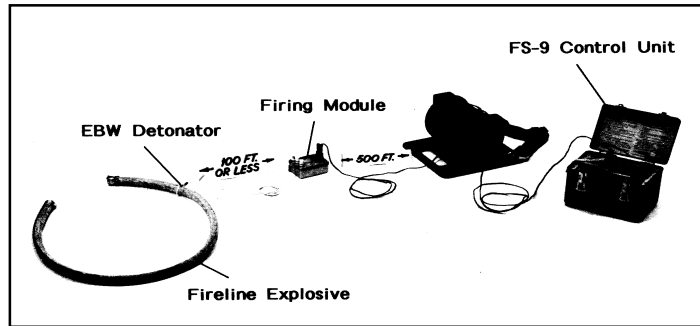

(Figure 11-12) Exploding bridgewire firing system

The blaster-in-charge must have all EBW detonators and the control unit under personal control during all blasting operations.

There are two methods of deployment: 1) The carton or reel of explosives can be carried and the end of the cord held stationary; or 2) The carton or reel can be held stationary and the cord pulled from the reel or box. After deployment, the ends of adjacent cords are overlapped 6 inches to 8 inches and attached (taped) together (Figure 11-15).

When properly attached, any number of cords can be fired with a single detonator. The number of cord lengths per blast or shot will be determined by the blaster-in-charge.

The explosive is most effective when placed on or near the ground and under downfall. Large logs can be sawed, wrapped with the explosive, or left for later sawing.

After the explosives are placed, the blaster-in-charge, through a designated assistant, if necessary on large layouts, shall assure that the cord is properly positioned, and all joints are securely taped, tied, or clamped together. The assistant blaster should then move to a position at least 500 feet beyond the end of the fireline cord. The blaster-in-charge must also be at least 500 feet from the charge.

The assistant blaster and any guards shall be a minimum of 500 feet from the explosive and guard the area from all intruders from any direction. Guarding the area is most critical to the safety of the operation because inadequate guarding is the most common cause of explosive-related accidents.

The blaster-in-charge must positively determine that all guards are properly placed, all other crew members are in a safe area, and that the blasting zone is clear of all personnel for at least 500 feet. Care should be exercised when selecting safe areas to ensure adequate protection from flying objects, falling rocks, tree limbs, and objects that might ricochet.

Detonator Connection Sequence

Check the continuity of the secondary lead wire (low voltage) with the galvanometer. This is done by stripping about two inches of insulation from the wire, shorting one end of the lead wire, and touching individual wires at the other end to the poles of the galvanometer (See Figure 11-16).

The EBW detonator lead wire need not be shunted during shipping or while performing the hookup procedure. Check the continuity of the EBW detonator with the galvanometer. Connect the detonator to the primary high voltage lead wire. (This is done by placing a lead wire and a detonator wire parallel to one another, then making a loop.)



(Figure 11-13) Control unit

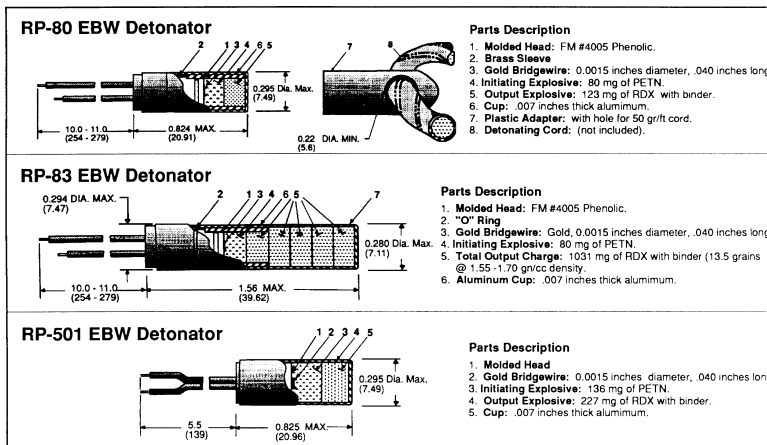

(Figure 11-14) Exploding bridgewire detonator

Check with guards by radio. If safe to continue, yell "Fire in the Hole" or "Fire One" (first call).*

*In Alaska and some other locations "Blasting One," "Blasting Two," and "Blasting Now" are substituted for "Fire in the Hole" or "Fire One."

Attach the detonator to the explosive. (This is typically done by inserting the cap into the explosive with the end of the cap pointed in the direction that the explosive was deployed (Figure 11-17).

When using the RP-80 directional detonator and a seven-strand detonator cord, place the detonator perpendicular to the fireline explosive (Figure 11-18). Tape the detonator into place so it cannot be dislodged, or tape securely to outside. Be sure that the wire leads do not touch each other or any other materials such as leaves and grass. Move to the module.

Connect the secondary lead wires coming from the firing module to the FS-9 control unit. (There are two wire screw plugs where these will be connected).

Check with guards by radio. If all clear, yell “Fire in the Hole” or “Fire Three” (third and final call).

Insert the shunting plug into the safety interlock provided on the control unit. (Shunting plug must be plugged in or the entire system will not work.) Depress the “Hold to Arm” button. The “Battery OK” light should illuminate within two seconds.

Simultaneously activate the “Hold to Arm” switch and “Hold to Fire” switch. When both are activated, the “ready” light will illuminate. Detonation will occur between two to eight seconds from the time both switches are activated.

Post-fire Procedures

Remove the shunting plug from “Safety Interlock” connection on the control unit. This renders the control unit inoperable.

Call the end guard at the far end of the line. Tell the guard to check that end to see if detonation was complete.

Note: The end guard is the only other person, besides the blaster-in-charge, cleared to enter the blast site at this time.

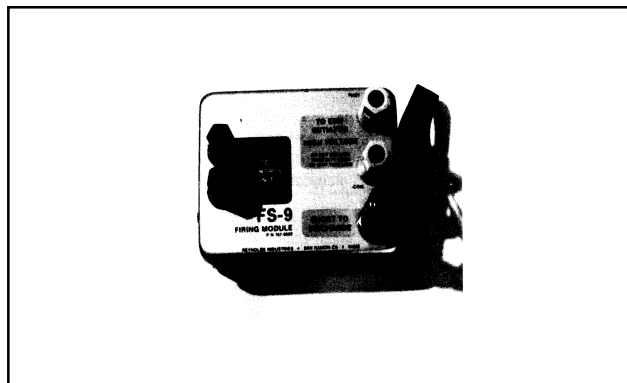

(Figure 11-15) FS-9 control unit

Disconnect the lead from the terminal marked "To Firing Module" at the control unit. Short the lead wires together for future electrical continuity checks and move to the firing module. Be sure to take the shunting plug.

Insert the shunting plug into the "Safety Interlock" connection on the firing module. This renders the firing module inoperable and bleeds off any excess electricity.

Disconnect lead wires from the terminals marked "To Control Unit" at the firing module. Disconnect lead wires from the terminals marked "To EBW Detonator Only" and move to the fireline.

Check to make sure all the explosives have detonated and check with guard at the far end of the line to confirm that all of the explosives detonated at that end. Radio all guards that it is clear to enter the blasting area.

If the guard on the far end of the line finds undetonated explosives, keep all personnel out of the area and notify the blaster-in-charge. The blaster-in-charge will walk the line and determine why the explosive did not detonate. If the cause is an improper connection, attach a new cap to the end of the explosive and detonate it using the same procedures previously outlined.

If the explosive is burning, clear the area and wait until it has burned out. Before proceeding, the end guard will secure the approval of the blaster-in-charge and check again to be sure conditions are clear before allowing the crew to return.

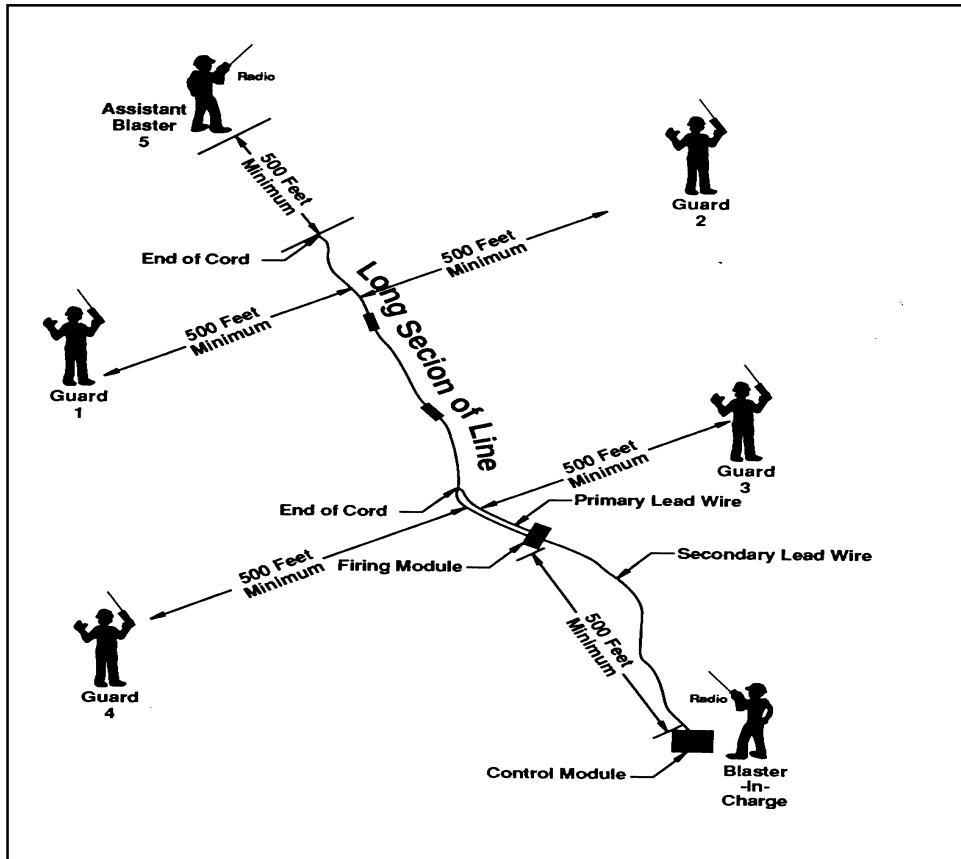

(Figure 11-16) Example of explosive layout and placement of guards.

Misfire Procedures

In the case of a misfire, the detonator received either insufficient energy or an energy pulse with an incorrect rise time or frequency pulse. On rare occasions, the cause may be a faulty detonator. If the initial energy pulse is insufficient to break the bridgewire, the detonator may not be accidentally detonated. It is safe to handle immediately and is not hazardous in this condition. The only possible hazard is the fireline explosive. Once it has been established by the blaster-in-charge that it is safe to proceed to the explosive, the following procedure should be used:

1. Remove the shunting plug from the "Safety Interlock" connection at the control unit.
2. Recheck the batteries and fuse. If the fuse is blown, the wires between the control unit and the module could be shorted. Correct this condition, replace the fuse, and restart the firing procedure. If this is not the case, disconnect the wires at the control unit from the terminals marked "To Firing Module" and shunt them so the continuity can be checked at the firing module.
3. Return to the firing module with the blasting galvanometer and shunting plug.

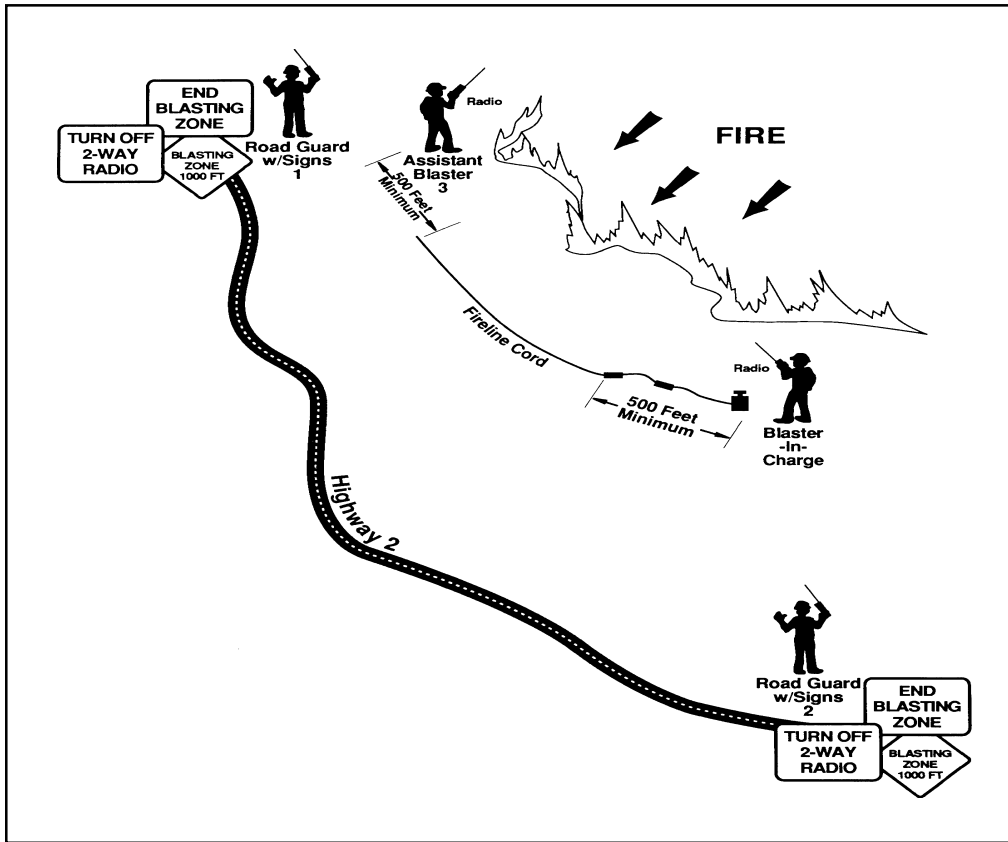

(Figure 11-17) Example of placement of guards when blasting close to roads or any public facility. Guards are numbered by blaster-in-charge

4. Disconnect wires at the firing module from the terminals marked "To Control Unit" and check for continuity. If continuity is not indicated, determine where the wires are broken and repair or replace. Then restart the firing procedure.



(Figure 11-18) Splice on fireline explosive

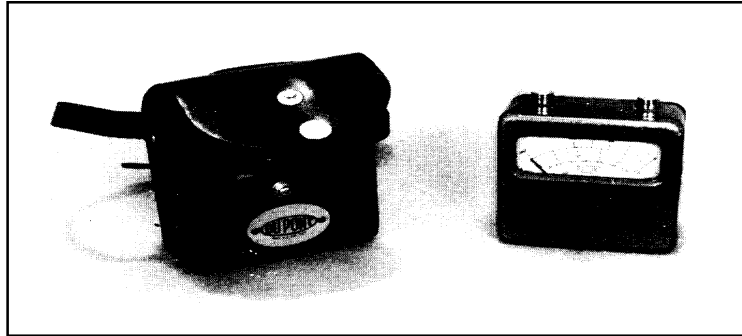

5. Disconnect wires at the firing module from terminals marked “To EBW Detonator Only” and check for continuity. If continuity does not exist, the electrical pulse did not reach the detonator and either the lead wires are broken or the detonator is faulty. Shunt the lead wires at the firing module.
6. Return to the detonator. Disconnect the detonator and check continuity of both the detonator and lead wires. Replace either item if continuity is not indicated. During this procedure, if all components appear normal, replace the detonator and the primary lead wire from the detonator to the firing module. The most likely cause of a failure is within the twin lead wires because of the high voltage of the firing pulse.

An additional check may be performed on the primary wire. If the insulation is damaged on the wire from the firing module to the detonator, the firing pulse may arc across these points or to the ground, causing an insufficient energy pulse to reach the bridgewire in the detonator. It is a good practice to check both the secondary and primary lead wires for breaks when coiling them. When setting up, the blaster can let the wire run through either hand while walking along the line. Breaks in the insulation can often be felt in this manner, then repaired or replaced.

Other Considerations

If a portion of the explosives did not detonate, and if it is not threatened by fire, cut off any mangled or otherwise damaged explosive material and attach it snugly to the good cord a foot or more from the cut end. Place a new detonator in the cord and go through the firing procedure.

If for some reason it is impractical to shoot a failed portion of explosive material, it can be placed in one of the original boxes and returned to the magazine. If this is done, be sure to make the person in charge of the magazine aware of it.

If you have explosives in a vehicle on a return trip, be sure to leave the explosive placards in place. If you have no explosives other than detonators, placards must be removed from the vehicle before starting the return trip.

Remember to return any remaining explosives including detonators to an approved magazine, and see that any needed corrections are entered in the magazine inventory. Maintain a shot log or blasting record showing the date and time of each blast and the amount and type of explosive used.

BURNOL BACKFIRING DEVICES

GENERAL

- a. Burnol backfiring devices (Figure 11-19) consist of a metal canister of gelled flammable material and a cap, fuse, and ignition system with additional ignition material in a plastic container around the cap.
- b. Burnol is a useful burning tool, but it has an explosive device (blasting cap). It is potentially hazardous if misused. Because these devices are commonly used by fire management personnel who do not normally work with explosives, it is very important that they be properly trained in the safe use of the product.

STORAGE

- a. Storage of Cap-and-Fuse Assembly - Ignitor shall not be installed on cap-and-fuse assembly in storage.
- b. Permanent Storage - Storage shall be in accordance with Chapter 3 of this guide. Storage must be in type one or two magazine and inspected once every seven days.
- c. Temporary Storage - With road access, Burnol backfiring devices must be stored in a type 3 magazine and must be attended. Without road access, store in accordance with Chapter 3.
- d. Grenade Features - Ignitor shall not be installed on the fuse before shipment. Shunted cap and fuse assembly shall be used.

TRANSPORTATION

- a. Transportation shall be in accordance with 49 CFR and Chapter 4 of this guide.
- b. Vehicle shall be driven by qualified driver as defined in Chapter 4 and shall not be left unattended.
- c. Cap-and-fuse assembly shall be in portable magazine or IME container.
- d. Vehicle shall be placarded only when transporting more than 1000 devices.
- e. Vehicles transporting explosives shall be equipped with two 1-BC or larger fire extinguishers.

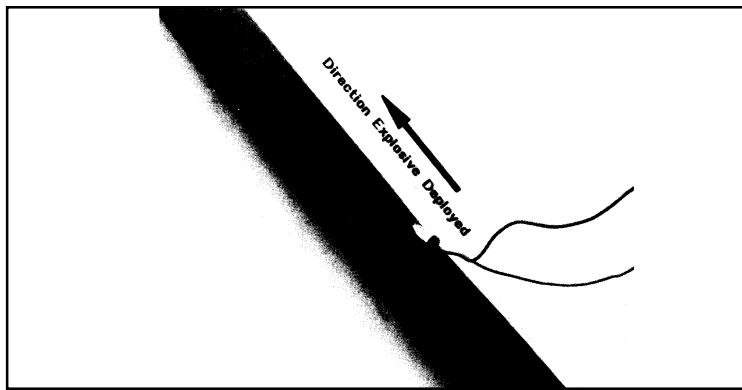

(Figure 11-19) Splice on fireline explosive.

USE PROCEDURES

- a. Users shall be certified NPS blasters.
- b. Cap-and-fuse shall be installed on the device at the work area.
- c. The ignitor shall be installed on the fuse at the shot point when the user is ready to throw the device.
- d. The user shall install the ignitor, activate it, and throw it immediately.
- e. Misfires will not be retrieved for at least 15 minutes.

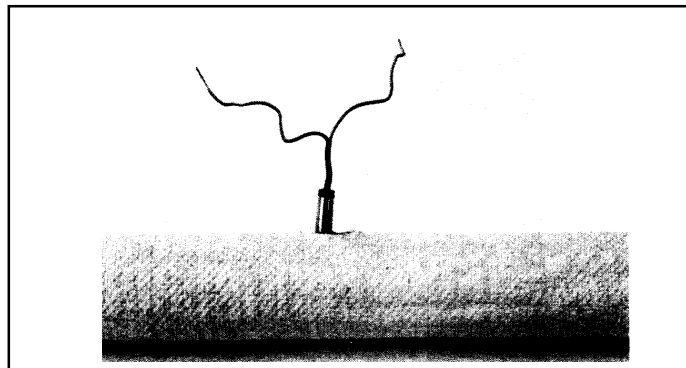

(Figure 11-20)

ANIMAL CARCASS REMOVAL WITH EXPLOSIVES

Various patterns of charge placement are used, depending upon the size of animal carcass to be removed. For instance, 20 pounds of Kinepak or 60 percent gelatin may work on a horse weighing under 1000 pounds, but will prove inadequate for an animal weighing 1400 pounds. In general, desired explosives properties for animal removal include:

- a. Mid- to high-level density explosives.
- b. A velocity over 16,000 fps.
- c. Total charge weight range of a minimum of at least 20 pounds for horses weighing under 1000 pounds (and bears under 400 pounds) up to 50 pounds (or possibly more) for larger carcasses. (Top loading the body and head of the animal may be necessary to assure complete shredding of the carcass.)

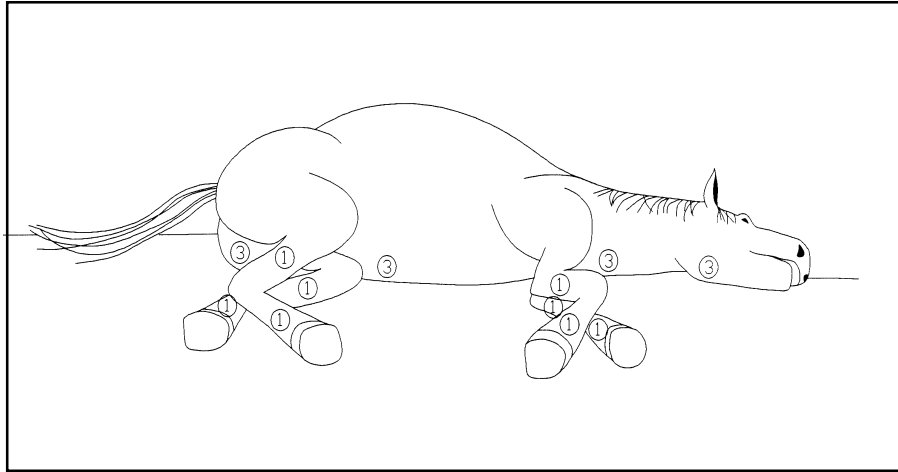

(Figure 11-12)

Following is one basic pattern of charge placement:

1. Each set of charges must be placed under the carcass.
 - a. Four locations: three pounds each, under the main mass.
 - b. Each leg, two locations: one pound each, detcord wrapped around each charge.
 - c. Legs could be packed with water bags.
 - d. Horseshoes should be removed for safety.
2. Charges could be put in place and the carcass then rolled over on top of them.
3. Approximately 20 pounds explosive, 12 caps, and 20 to 30 feet detcord.

MECHANICAL ASSIST: NON-DETONATING ROCK BREAKING TOOL

FUNCTION OF THE TOOL

The non-detonating rock breaking tool can do anything a small diameter blasthole charged with conventional explosives can do, but in a safer and much more controlled manner. The greatest difference seems to be that it splits the material rather than shatters it. It will break reinforced concrete and boulders, or the rock ledges and shiners encountered in excavation projects, with the energy that is contained in one or several shotgun shell size cartridges. Caution: Even though this product does not represent a 'detonation process' great care must be taken to protect crews and equipment from fly-rock potential.

PRINCIPLE OF THE ROCK BREAKING TOOL

This device works on the principle of breaking rock (or smaller materials) with tension, through energy transfer to non-compressible water, from rapidly expanding gas pressure. In conventional breaking with chemical explosive, the energy developed in the reaction (the explosion) continues until the chemical products are consumed, even after its work is finished. If there is more energy available than needed to split or break the

material, the continued gas expansion can result in excessive shattering, movement and throw.

The difference in the non-detonating rock breaking tool technology is that, upon initiation, all the propellant's energy is transferred completely to the column of water in the drill hole. Then, because water cannot be compressed, it is driven and wedged like a solid into the existing micro-cracks in the rock or concrete. Once the material splits, the confinement forces acting on the water are relieved, and the residual energy in the water dissipates harmlessly. The result is splitting and breaking without excessive fragmentation, scatter, or noise.

BENEFITS OF THE ROCK BREAKING TOOL

Since this system breaks material with a negligible amount of flyrock, no noxious fumes, and almost no ground vibration, it allows rock to be broken in the most restrictive circumstances. For example, it can be used to break oversize rocks in the jaws of a crusher or on a grizzly without risk of damaging the equipment. In addition, it is used in very tight excavation situations where explosives are not allowed or are inappropriate; and where it is not possible to use hydraulic demolition hammers.

With this tool, hard excavation near sensitive objects including high pressure gas lines, telephone, power or optic cables, in or near buildings, and in crowded construction sites can be done safely and quickly.

Best of all, there are not any restrictive regulations affecting the storage, transportation, or use of the tool or the cartridges.

WHO CAN USE THE ROCK BREAKING TOOL

Any good worker with a grasp of the safety aspects of the tool and an understanding of its basic principles can operate it. An explosives users license is not required. Federal agencies (DOT and BATF) determined that the device and the cartridges, when used properly, did not pose any significant threat to the health or safety of the users or the general public.

The cartridges were placed in the same category as nail gun cartridges. This is classed as a hazardous material (Explosive 1.4S-UN0323), but it is judged to present a minimum hazard during transport and storage. The cartridges and the tool can be shipped within the United States by common carrier, including UPS (air).

USE OF THE NON-DETONATING ROCK BREAKING TOOL

The application of this technology is simple:

1. Drill a 1 1/2" hole; fill it with water.
2. Drop one or more booster cartridges in the water, place the device in the hole, and place a mat or some sandbags over the device.
3. Load the primer cartridge and set it off mechanically by pulling a lanyard from a distance of 21 feet from the rock when the device is used.

Depending upon the breakability of the material, a hole can be drilled in from the edge or face (burden) at any distance ranging from a 1 1/2 feet, to as much as 4 feet.

BEST USE OF THE ROCK BREAKING TOOL

The type of work required will dictate the proper method for using the non-detonating rock-breaking tool. In general, the procedures include either breaking or splitting an entire unconfined mass, such as an exposed surface boulder, or precisely breaking pieces from a confined or partly covered object for a particular purpose, such as completing an excavation or opening a trench.

When an unconfined rock needs to be split, a hole should be drilled to a point that is just beyond the center of the mass. The tool can then be used to reduce it to several pieces. If the size of the entire mass cannot be determined, such as when bedrock or large rocks are encountered in an excavation, then the hole

needs to be positioned and drilled deep enough so that the proper sized piece of material will be broken or split from the edge.

BOOSTER CARTRIDGES

For larger boulders and rocks, booster cartridges are available. The in-hole boosters allow the user to adjust the amount of energy to match the strength or the size of the material to be broken.

Two different booster cartridges are available. The smaller cartridge contains 10 grams of propellant while the larger contains 15 grams. A maximum of up to three booster cartridges may be dropped into the water-filled hole before inserting the breech body. Several simple methods can be used to space the cartridges evenly along the length of the hole for better results. In a situation where the rock or boulders are porous, or cracked and will not hold water, a thickening agent or gel is effective.

REINFORCED CONCRETE

The non-detonating rock breaking tool can be used to weaken heavily reinforced concrete to expedite removal with mechanical demolition tools.

Example: A pattern is drilled to 80 percent of the depth of the concrete (about five feet deep for a six-foot thick mass). A small the hydraulic demolition hammer finishing the work. Overall time to do the work is significantly reduced, resulting in substantial savings.

AIR GAPPING

DEFINITION OF AIR GAPPING

In order to crack a rock with a minimal amount of explosives the air gapping method may be used. This technique requires that a hole is drilled three-quarters of the way through a boulder that is positioned on a surface or at ground level with no confinement. Depending on the size, there may be one or five to six holes located in strategic places determined by the blaster.

Only one hole is loaded; the additional boreholes are for a relief effect. The desired outcome is to produce no flyrock and reduce the size of the boulder to remove it more easily by hand or with equipment. Only one borehole may be used if the boulder is two cubic yards or less in size.

CHARACTERISTICS OF AIR GAPPING

In air gapping, there is a minimal amount of powder used to break a rock without producing flyrock or damaging surrounding environments or structures. This method does not work well with buried rock, since it has no place to expand and crack. Rock should be above ground, with no confinement. Possible hazards include: spacing holes too closely together; overcharging, which could create flyrock; fumes, and static electricity.

Powder Type and Caps: Stick powder, emulsion, water gels, or two-component explosives according to the type of rock to be blasted. Any type of authorized cap is acceptable.

PROCEDURES

Air gapping works best by drilling a hole slightly larger than the size of powder that will be used, three-quarters of the way through the rock. Angles should be as vertical as possible. Powder factor varies (dependent upon the size of the target or rock) per yard of boulder.

Insert powder halfway down the borehole using, in general, six-ounce cap wires to hold it in place, stemmed with a rag and/or a mud cap. Electric caps are detonated instantaneously. Another air gap application includes pouring water into the borehole to enhance the confinement and hammer effect, after the explosives have been

placed.

EXPANSION ALTERNATIVES

EXPANDING GROUT

Expanding grout is a soundless and safe demolition agent that is quite different from ordinary demolition agents such as explosives and other dangerous materials. It does not cause any flyrock, noise, ground vibration, gas, dust, or any other environmental pollution when used properly.

As requirements for demolishing rock and reinforced concrete in construction increase in tight quarters, the use of explosives and explosive agents becomes more restricted in regard to safety and environmental pollution problems.

When expanding grout is mixed with an appropriate amount of water and poured into cylindrical holes drilled in rock or concrete, it hardens and expands. The grout cracks the matter to be demolished, allowing for easy removal with a pick breaker, pneumatic breaker, excavator, etc.

There are currently four grades of expanding grout on the market designed for various temperature ranges of material to be cracked. Since a chemical reaction of expanding grout depends on temperature, use the proper type of material.

ADVANTAGES OF EXPANDING GROUT

Safety - Expanding grout is not controlled by any legal regulation such as explosives and explosive agents, etc. Specific qualifications are not required for handling. Demolition can be performed anywhere, easily and safely.

Noise - Expanding grout is a soundless cracking agent. Unlike the existing methods of demolition, it does not make any noise, vibration, flyrock, dust or gas. Rocks and reinforced concrete may be demolished safely without environmental pollution. Furthermore, the grout's expansive stress continues even after crack initiation and the crack opening distance becomes wider as time passes.

Handling - No lid (or cap) is necessary after expanding grout is poured into a hole of rock or reinforced concrete, nor is tamping required as with explosives. Expanding grout exerts its strength in a short time. Due to the grout's strong adhesion and frictional resistance to inner surface of the hole, spurs due to heat-generation (blown-out-shot) do not occur when used within the parameters as noted in the conditions. The expansive stress along the hole depth is almost constant except for that near the entrance of the hole. Generally, the expansive stress loss from the hole entrance has little effect on the demolition work when hole depth is long.

Expansive Stress - Expanding grout has an expansive stress of more than 6000 t/m². In general, the compressive fracture stress of rocks is 1000 to 2000 kg/cm², while that of concrete is 150 to 500 kg/cm². However, the tensile fracture stress is very small, i.e., it ranges from 40 to 70 kg/cm², respectively. Since demolition is based on a fracture due to a tensile stress, all types of rocks and concrete can be cracked and broken when appropriate holes are properly drilled.

PROPERTIES OF EXPANSIVE GROUT

Chemical Components - Expansive grout is a powder consisting of an inorganic compound comprised mainly

of a special kind of silicate and an organic compound. It does not contain any harmful components.

Effects on Expansive Stress - The expansive stress of the grout increases more than 6000 t/m². The larger the hole diameter is, the greater the expansive stress becomes. There is little change in the expansive stress when the water ratio is approximately 30 percent. However, the stress is decreased as the water ratio is increased or decreased.

FRACTURE MECHANISM

After the grout is poured into holes drilled in rocks or concrete, the expansive stress gradually increases with time, and reaches to more than 6000 t/m² at room temperature after 24 hours. As the product generates its expansive stress, the material to be cracked undergoes a process of (1) crack initiation, (2) crack propagation, (3) the increase of crack width. Therefore, this fracture mechanism is distinguished from a breakage by blasting.

Cracks initiate from an inner surface of the hole and are caused by tensile stress at a right angle with the compressive stress which occurs by the expansive stress of Bristar. The expansive stress continues even after the appearance of cracks. The cracks propagate and new cracks also initiate during the process. Usually, for a single hole, two to four cracks initiate and propagate. When a free surface exists, the crack is pushed apart by the shear stress and a secondary crack also arises from the bottom of the hole running toward the free surface.

TEST BREAK AND DRILLING

The effectiveness of expanding grout depends on the placement of the holes. The drilling must be done in relation to the job to be performed.

Test Design and Breaking - The design for breaking should be done according to the properties of rocks, joint, volume to be removed, secondary breaking, and work period, etc.

To determine which combination of hole size and spacing is most desirable, drill several holes of different diameter at different burden and spacing. Check each of the break conditions, and then decide hole diameter, depth, burden and spacing.

Drilling - Drilling machine: Use electrical drill, rock drill, or crawler drill. Drilling direction: It is preferable to drill holes vertically, but in cases of a wall or pillar of reinforced concrete where vertical drilling is hard, an inclined hole may be drilled. Since a greater effect is achieved with a deeper hole, in case of a thin material, consideration should be given to achieve a long hole depth by drilling it obliquely if necessary. Horizontal holes require the same spacing as vertical holes.

Hole Diameter and Hole Spacing - In general, the preferable hole diameter is from 40 to 50 mm (1 1/2" x 2").

Hole Depth - This varies with the shape of the material to be cracked or the break plan. It should be noted that Bristar mixed with water can easily be applied by hand when the hole depth is up to approximately 10 meters. When the hole depth is less than three times the diameter of the hole, less cracking will occur. The breaking effect is lessened and the time required for demolition is increased.

Use of Thin Steel Pipe - In the case of a temporary concrete structure (to be demolished), place thin steel pipes (the thickness: 0.8mm (1/32") i.e., a sheath pipe for P.S. concrete) as holes before placing concrete—instead of drilling. Whenever the structure needs to be cracked, fill Bristar in the pipes. There is no change in breaking effect by the use of pipe.

MIXING AND FILLING EXPANDING GROUT

Mixing - Mix one bag (5 kg, 11 lb) with water at a time by hand or preferably with a mechanical mixer. Prepare the following equipment:

Container - For one bag, a metal bucket or clean can of 10-20 liters capacity.

Mixer - For instance, a hand-mixer.

Water meter - Beaker or measuring cylinder.

Protector - Rubber gloves, safety goggles.

Mixing Method - Pour approximately 1.5 liter (0.4 U.S. gallon) of water into container. Gradually add one bag of Bristar, and mix well until a good fluidity occurs. When the viscosity of the mixture of expanding grout and water is too high to pour into the hole, add a little water to get a good fluidity. Do not exceed 34 percent of water ratio (1.7 liter; 0.45 U.S. gallon per 5 kg; 11 lb).

The mixing time by hand-mixer is about 2-3 minutes. (It is recommended that a mechanical mixer be used on large volume jobs.). When mixing by hand, wear rubber gloves. Always use clean mixing water.

Standard Quantity - The quantity of Bristar to be used for cracking differs with the hole spaces and diameters.

Filling of the Hole with Expansive Grout - Expansive grout should be poured into holes within 10 minutes after mixing with water. Grout may set up within 10 minutes, losing its fluid properties and becoming difficult to pour. Once its fluidity is gone, the grout should not be diluted by re-mixing with water, since its strength is greatly reduced.

Expansive grout is best placed using a bucket with a pour spout, caulking gun, or grouting pump, especially for a horizontal hole. Try to drill horizontal holes with some slope to help in filling. Grout must be poured into a hole to the brim. A horizontal hole can be plugged easily with grout as it reaches a clay-like consistency as it starts setting up. A slight slope makes use much easier.

The average quantity of grout used per one cubic meter is 5kg for the material to be broken when working at in untouched rock (8, 4 lb/yd³). For fragmentation and reinforced concrete, an amount of two to four times of that is required.

USE OF POLYETHYLENE SACK IN THE HOLE

If there is water in the hole, place a polyethylene thin sack equal to the hole diameter into the hole, insert a wooden rod into the bag, and then fill grout into the sack. The grout in the sack will displace the water in the hole. There is no change in the breaking effect by the use of this kind of sack.

When there are many joints or large voids in the material to be cracked, or when grout somewhat leaks from the hole, use the sack. When much water of the slurry is absorbed to the material to be cracked (i.e., a dry concrete), use the sack, or spray water into the hole. In freezing temperatures, avoid using water.

When material to be cracked is in water, try to use the bucket or the pump when filling into the pipe. Remove it and then tie the sack to avoid grout-filled diluting. If there is no flow of water around an entrance of the hole, expansive grout may be directly poured into the hole using the pump, and should gently displace the water in the hole.

AFTER TREATMENT

Tamping with mortar or sand is not required after the filling of grout. It is not necessary to put on any restrictive cap either. Simply leave the grout, and wait until a crack initiates. Covering the filled hole with a plastic cover is desirable to avoid dilution of grout from an external water source until cracking starts.

Spraying the surface with water after the cracks initiate tends to increase the width of cracks and speed the cracking process.

TIME REQUIRED FOR CRACK FORMATION

The time required for crack formation in material at 20 degrees C (68F) is about 10 to 20 hours. The lower the temperature the longer crack formation takes. The crack width for rock continue to increase with time and can become 10 to 30mm (3/8” to 1 1/8”) after several days, depending on free surfaces available. It is best to wait until the grout has worked to full depth before removing rock as premature removal at the first sign of a crack can hamper the leverage effect of expansive grout.

CONTAINERS AND STORAGE

Expansive grout is packed in four anti-moisture bags of 5 kg (11 lb) each and then placed in a waterproof carton with a total weight of approximately 20 kg (44 lb)

Although grout is packed in anti-moisture paper bags, prolonged storage may cause deterioration of its working ingredients. Therefore, store grout in a dry place and use it as soon as possible. When storing, do not place the bags of grout directly on floor. Put them on a pallet and keep the bags in a dry warehouse. Stored in this manner, grout can be effectively used for about one year.

Grout should be unpacked before use. When storing the remaining portion of grout, push the air out of bag, then seal it with gum tape and use it as soon as possible. However, since it may be exposed to moisture, there is risk of the grout losing its effectiveness once the bag has been opened. If broken bags of grout are received, they may not function due to moisture absorption.

PRECAUTIONS

Do not use grout for other purposes besides the cracking of rocks or concrete. Rinse with water any portion of the skin that comes in contact with grout. Wear rubber gloves and safety goggles when mixing and filling.

To avoid shattering of containers, do not pour and leave grout in bottles or cans. Do not look directly into any holes for at least six hours after pouring. Grout may splatter or blow out of the hole due to heat generation when the temperature of the material to be broken is overheated. Never use hot water with expanding grout.

Common Uses

A variety of applications commonly employ nonexplosive demolition agents such as expanding grout.

Bridge Piers and Caps	Boulders	Concrete vaults
Foundations	Pre-Splitting	Bridge columns
Machinery Bases	Trench Rock Removal	Concrete slabs
Building Walls	Tunneling	Sea walls
Bridge Abutments	Shafting	