



# The Electric Power System of the International Space Station—A Platform for Power Technology Development

Eric B. Gietl  
Boeing, Houston, Texas

Edward W. Gholdston  
Boeing, Canoga Park, California

Bruce A. Manners and Rex A. Delventhal  
Glenn Research Center, Cleveland, Ohio

## The NASA STI Program Office . . . in Profile

Since its founding, NASA has been dedicated to the advancement of aeronautics and space science. The NASA Scientific and Technical Information (STI) Program Office plays a key part in helping NASA maintain this important role.

The NASA STI Program Office is operated by Langley Research Center, the Lead Center for NASA's scientific and technical information. The NASA STI Program Office provides access to the NASA STI Database, the largest collection of aeronautical and space science STI in the world. The Program Office is also NASA's institutional mechanism for disseminating the results of its research and development activities. These results are published by NASA in the NASA STI Report Series, which includes the following report types:

- **TECHNICAL PUBLICATION.** Reports of completed research or a major significant phase of research that present the results of NASA programs and include extensive data or theoretical analysis. Includes compilations of significant scientific and technical data and information deemed to be of continuing reference value. NASA's counterpart of peer-reviewed formal professional papers but has less stringent limitations on manuscript length and extent of graphic presentations.
- **TECHNICAL MEMORANDUM.** Scientific and technical findings that are preliminary or of specialized interest, e.g., quick release reports, working papers, and bibliographies that contain minimal annotation. Does not contain extensive analysis.
- **CONTRACTOR REPORT.** Scientific and technical findings by NASA-sponsored contractors and grantees.

- **CONFERENCE PUBLICATION.** Collected papers from scientific and technical conferences, symposia, seminars, or other meetings sponsored or cosponsored by NASA.
- **SPECIAL PUBLICATION.** Scientific, technical, or historical information from NASA programs, projects, and missions, often concerned with subjects having substantial public interest.
- **TECHNICAL TRANSLATION.** English-language translations of foreign scientific and technical material pertinent to NASA's mission.

Specialized services that complement the STI Program Office's diverse offerings include creating custom thesauri, building customized data bases, organizing and publishing research results . . . even providing videos.

For more information about the NASA STI Program Office, see the following:

- Access the NASA STI Program Home Page at <http://www.sti.nasa.gov>
- E-mail your question via the Internet to [help@sti.nasa.gov](mailto:help@sti.nasa.gov)
- Fax your question to the NASA Access Help Desk at (301) 621-0134
- Telephone the NASA Access Help Desk at (301) 621-0390
- Write to:  
NASA Access Help Desk  
NASA Center for Aerospace Information  
7121 Standard Drive  
Hanover, MD 21076



# The Electric Power System of the International Space Station—A Platform for Power Technology Development

Eric B. Gietl  
Boeing, Houston, Texas

Edward W. Gholdston  
Boeing, Canoga Park, California

Bruce A. Manners and Rex A. Delventhal  
Glenn Research Center, Cleveland, Ohio

Prepared for the  
2000 Aerospace Conference  
sponsored by the Institute of Electrical and Electronics Engineers  
Big Sky, Montana, March 18–25, 2000

National Aeronautics and  
Space Administration

Glenn Research Center

## Acknowledgments

The authors would like to gratefully acknowledge the review of sections of this paper relating to the Russian segment by Vladimir Savenkov of Cosmos ENVO in Moscow.

Available from

NASA Center for Aerospace Information  
7121 Standard Drive  
Hanover, MD 21076  
Price Code: A03

National Technical Information Service  
5285 Port Royal Road  
Springfield, VA 22100  
Price Code: A03

# The Electric Power System of the International Space Station – A Platform for Power Technology Development

Eric B. Gietl  
Boeing—Houston  
Houston, Texas 77058

Edward W. Gholdston  
Boeing—Canoga Park  
Canoga Park, California 91309-7922

Bruce A. Manners and Rex A. Delventhal  
National Aeronautics and Space Administration  
Glenn Research Center  
Cleveland, Ohio 44135

*Abstract*—The electrical power system developed for the International Space Station represents the largest space-based power system ever designed and, consequently, has driven some key technology aspects and operational challenges. The full U.S.-built system consists of a 160-Volt dc primary network, and a more tightly regulated 120-Volt dc secondary network. Additionally, the U.S. system interfaces with the 28-Volt system in the Russian segment. The international nature of the Station has resulted in modular converters, switchgear, outlet panels, and other components being built by different countries, with the associated interface challenges. This paper provides details of the architecture and unique hardware developed for the Space Station, and examines the opportunities it provides for further long-term space power technology development, such as concentrating solar arrays and flywheel energy storage systems.

## 1. INTRODUCTION

The International Space Station (ISS) Electric Power System (EPS) consists of a hybrid mix of two major segments: a 120-Volt U.S.-built portion, and a 28-Volt and 120-Volt Russian-built portion. The two systems are generally independent, but are interconnected via dc converters to allow mutual transfer of power depending on availability and system demand. Orbital assembly of the Station has already begun, and the characteristics of this combined system present unique challenges to operation, as well as excellent opportunities for proving out new power technologies with wide application in various types of spacecraft. As with other aspects of the Space Station, the design and implementation of the EPS is truly an International

integration effort, with inter-operable hardware such as switchgear, core loads, and output panels being provided by several different International Partners. In most cases, the Station hardware designs have pushed the technology envelopes for power levels, energy densities, and thermal environments.

The two basic segments of the Station will first be considered separately, and then together as a balanced system.

## 2. U.S. SEGMENT

The 120-Volt system in the U.S. segment is a channelized, load-following network of extensive solar arrays, batteries, voltage converters, remote controlled switchgear, and cables to route power to users in the U.S., European, and Japanese Modules. Figure 1 shows a top-level representation of the power flow through the U.S. system, and indicates the interconnections with the Russian system. Even during the earliest portions of the assembly sequence, power is transferred from the 28-Volt Zarya (the Russian Functional Cargo Block (FGB)) to the 120-Volt Node 1.

Figure 2 shows the U.S. Power System at Assembly Complete. The cluster of pressurized, inhabited modules in the center of the Station receive power from the solar arrays positioned out on the open truss structure which provides continuous sun tracking. The split-panel U.S. solar arrays are visible in the drawing, as well as the Russian arrays at the top of the large tower-like structure designated the Science Power Platform (SPP). For the U.S. segment, the four independent solar power modules will deliver a total of 76 kW of continuous power under normal conditions—with greater amounts during more optimum periods.

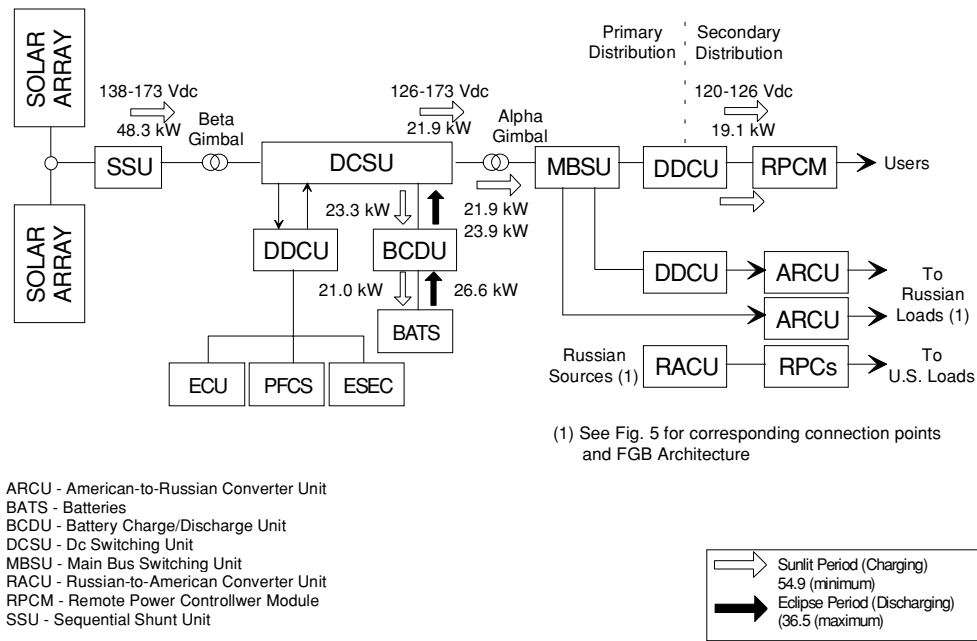

**Figure 1. Single-Channel Power Flow Diagram**

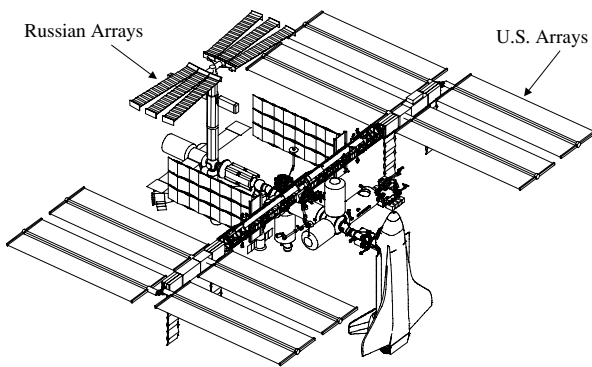

**Figure 2. ISS Assembly Complete Configuration**

Additionally, the Russian segment will possess a generating capacity of at least 29 kW, giving the Station a total projected capability of 105 kW.

The International Space Station will fly in low earth orbit at a 51.6-degree orbital inclination. This orbit results in an approximately 90-minute orbit where during portions of the orbit, the sun will not shine on the power generating solar arrays on the Station. During the Eclipse portion of the orbit, both the U.S. and Russian segments utilize battery-supplied power stored up during the sunlit period. The U.S. segment uses rechargeable nickel hydrogen (Ni-H<sub>2</sub>) batteries designed for 81 Amp-hours of storage capacity. The 51.6-degree orbital inclination creates solar illumination conditions that range from 35 minutes of eclipse per orbit, to periods where the Station remains in full sunlight for almost the entire 90 minutes. This orbital variability results in a wide range of power generation scenarios.

The U.S. portion of the EPS is divided into a primary system, which generates, stores, and distributes power over a network regulated anywhere between 173 and 115 Volts, and a 120-Volt secondary system, which is a tightly regulated network that feeds power to user loads throughout the Station. To minimize bulk and weight of power cables, the primary voltage is generally set at approximately 160 Volts, which is near the highest practical limit before plasma arcing becomes a concern. Primary power is routed to a distributed set of Dc/Dc Converter Units (DDCUs), which step the voltage down to 120 Volts, and isolate the secondary networks from each other. Each of the DDCUs can deliver up to 6.25 kW of power. Switching and fault protection for the loads is provided by combinations of six types of Remote Power Controllers (RPCs). These RPCs range in capacity from 3.5 to 65 Amps, with both current-limiting and non-current-limiting varieties. These units, along with the larger Remote Bus Isolators (RBIs) (relays) in the primary system, provide coordinated fault protection for the system, ensuring that the switching device closest to a faulted load or cable will trip first, minimizing the amount of the system affected when a breaker opens.

### 3. U.S. POWER SYSTEM ELEMENTS AND TECHNOLOGIES

The main elements of the U.S. primary system are replicated on each of the four solar power modules as shown in Figure 2 and include the solar arrays, the Sequential Shunt Units (SSUs), the batteries, the bidirectional Battery Charge/Discharge Units (BCDUs), the Dc Switching Unit (DCSU), and the associated cooling system pumps and thermal radiators. Rotating structural connections at the base of the arrays (denoted beta gimbals) provide one axis of rotation for solar pointing. The larger alpha gimbals (or Solar Array Rotary Joints (SARJs)) provide the other axis of

rotation and connect the power modules to the main truss structure of the Station. Each of these rotary joints transfers electrical power via a set of roll rings, which provide a continuous rolling electrical connection while the gimbal is rotating.

### Power Generation

As shown in Figure 2, the U.S. arrays are mounted on the solar power modules, and consist of matched sets of deployable, folded wings, that extend 34 meters (111.6 ft) out in opposite directions from the Integrated Equipment Assembly (IEA), which houses all of the electronics, batteries, and thermal control system for each independent module. The wings on each side of the center mast contain 82 strings of silicon solar cells, flexible printed circuits, and bypass diodes. Each solar cell assembly consists of an 8-cm square photovoltaic cell protected on the sun-facing side by a thin cover glass. The cells have a nominal efficiency of 14.5%, though it is better at the beginning of life, gradually tapering off over the 15-year life of the arrays. Each string consists of 400 cells, and provides approximately 160 Volts of primary power. The flexible printed circuit is a Kapton/copper/Kapton laminate welded to each cell to provide a series interconnection for the assembly. The bypass diodes are placed in parallel with every eight cells to minimize performance degradation resulting from damaged cells, and to eliminate potential cell damage due to reverse bias heating during partial array shadowing.

The electrical load that is drawing power from an array at any given moment constitutes a specific level of power demand. Denoting the power by P, the demand is met when Equation (1) is satisfied.

$$P = IV \quad (1)$$

where I is the array current, and V is the voltage. A representative load line is shown superimposed on the I-V curve of Figure 3. In this case, the load line, which traces out points of constant power, intersects the I-V at two places, so that two operating points are possible for the system. The SSU uses a set of solid-state switches operating at 20 kHz to dynamically shunt power from the 82 individual strings to follow load demand, thus regulating the bus, and holding the array at the lower voltage operating point.

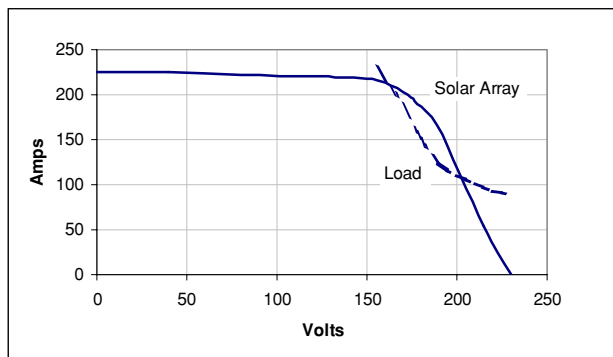

**Figure 3. Solar Array Power Curve with Representative Load Line**

### Plasma Contactor

As a result of the large area and higher operating voltage of the U.S. solar arrays (as compared to any previous spacecraft) and the nature of the single-point ground of the ISS power system, unique challenges need to be addressed with respect to operating in the plasma environment of space. The possibility of the 160-Volt array current arcing to the ambient space plasma is precluded by means of the plasma contactor. This device is mounted on the exterior truss structure, and operates by creating a plume of ionized xenon gas constituents, which acts as a low-impedance, conductive bridge between the Station and plasma environment. This protects the arrays and other conductive surfaces from arcing, pitting, and erosion by ion bombardment.

### Energy Storage and Distribution

For the U.S. system, energy is stored using actively cooled, nickel-hydrogen batteries specifically designed for high (40,000) charge/discharge cycles. Figure 4 shows a cut-away diagram of an individual battery box, two of which when connected in series make up a single battery rated at 81 Amp-hours. The 38 individual pressure cells in each battery box are monitored for pressure and temperature, which are used to continuously compute the battery state of charge. Nominal power system operation will result in cycling the batteries to a 35% depth of discharge, but under contingency conditions, deeper discharges are expected. The batteries are designed for 6.5 years of useful life, though they are planned to be replaced every 5 years to ensure available power margin.

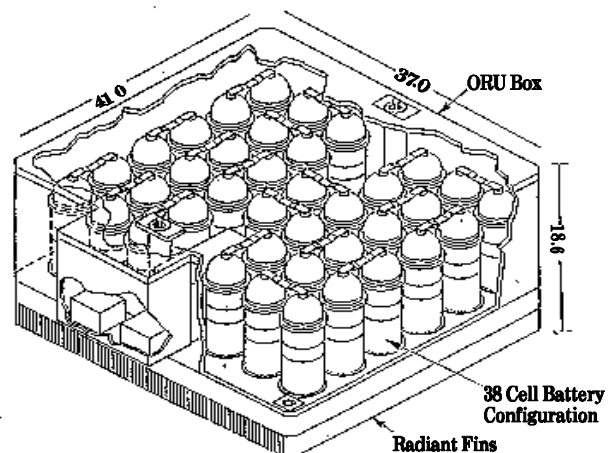

**Figure 4. Ni-H2 Station Battery Box**

As illustrated in Figure 1, power is routed across the alpha gimbals to the Main Bus Switching Units (MBSUs), containing RBIs (relays) which are capable of interrupting up to 350 Amps of dc fault current. The MBSUs serve as the main switching point for the primary system (and under emergencies can cross-tie any of the independent channels). From the MBSUs, power is routed to the DDCUs throughout the U.S. segment, and to the American to

Russian Converter Units (ARCU), which step the voltage down to 28 Volts) in the Russian segment.

The DDCUs are rated at 6.25 kW, and provide 20 dB of isolation between the primary and secondary systems, and step the voltage down to the 120-Volt level used by much of the U.S. and International Partner equipment. Because the load combination on the Station will be constantly changing as new core loads, payloads, and scientific experiments are brought aboard, to ensure maximum flexibility and compatibility of such a system, the DDCU output impedance, as well as input characteristics for loads, have been specified and designed to ensure stability with virtually any combination of expected loads. The derivation of these stability requirements are given in [1], and compliance has been demonstrated with engineering model and flight hardware.

The output of the DDCUs provides 120-Volt regulated power with 150% current-limiting capability for coordinated fault protection. Each DDCU feeds a downstream set of RPCs that are used to switch and route secondary power. There are six types of RPC Modules (RPCMs), with each type consisting of different combinations of rated switches ranging from 3.5 to 65 Amps. These breakers trip on different, preset values of overcurrent, overvoltage, and undervoltage to provide a fault protection system which isolates faults as closely as possible to the faulted equipment.

The control of the station EPS is by means of a fully redundant hierarchy of computers linked to each other and to the hardware via a network of MIL-STD-1553 control buses. The many autonomous functions (such as solar tracking, thermal control, and energy storage) allow the system to continue operating even if there are interruptions in local or ground communications. Power balance between the major segments is coordinated by the on-board Command and Control System, which provides interface control between the segments.

## 4. RUSSIAN SEGMENT OVERVIEW

### ***Russian Segment Power Generation***

The Russian power systems can be divided into two basic categories; a 28.5-Volt system and a 120-Volt system. The FGB and Service Module (SM) each contain 28.5-Volt systems rated at 3.5 kW and 4.4 kW, respectively. The 120-Volt system is distributed in the SPP and Universal Docking Module (UDM). Since the it is still in the design stages, it will not be discussed.

In order to understand the generation system operation, a description of the Russian system components is needed. Figure 5 shows a block diagram of the FGB Power System. The following devices are included:

Solar Arrays (CB), Solar Array Regulators (RT-50s), American to Russian Converter Units (ARCU), Nickel Cadmium batteries (Bloc 800A), Battery Charge/Discharge Devices (PTABs), Battery Current Controllers (BYPTs),

Amp-Hr Meters (MIRTs), Main Bus Bar (BSW), Bus Filter (BF)

The solar arrays are divided into strings with the number of strings determined by the total array capacity. The FGB contains six strings, while the SM has 12. Each array string is connected to a dedicated RT-50, which is a shunt regulator.

A single battery subassembly consists of one Bloc 800A, one PTAB, one BYPT, and three MIRTs) The FGB has six battery subassemblies, while the SM has eight. The Bloc 800A consists of 22 Nickel Cadmium battery cells. The beginning of life capacity is 90 Amp-hrs, and end of life after 2 years of service is specified at 60 Amp-hrs. The PTAB contains a dc-to-dc converter for charging and another for discharging. The BYPT is the device which determines the mode of operation in accordance with the commands from the ground. It controls charge current according to the signals of voltage, pressure sensors, MIRTs, and provides the telemetry data for the condition of the battery subassembly. The regime of charge or discharge is determined by the system control loop automatically depending on power balance. The BYPT also houses the battery cell drain resistors used for battery conditioning. The MIRTs are Amp-hr meters with a range from 0 to 60 Amp-hrs used for controlling charge.

For battery charging, the battery subassemblies can operate in two modes. In the complete (100%) charge mode, the batteries are charged to a point where either their terminal voltage reaches 34 Volts or a pressure transducer is activated. Charge current is set for 25 Amps if the MIRTs register less than 48 Amp-hrs and 10 Amps if above 48 Amp-hrs, until full charge is reached. In the incomplete (80%) charge mode, the batteries are charged to a point where the MIRTs read 48 Amp-hrs. In both modes of operation, the MIRTs use a 2-out-of-3 voting scheme. MIRTs installed in the battery subassembly have a compensation factor, which accounts for the inefficiencies in the charge/discharge process.

### ***Power Exchange Between U.S. and Russian Segments***

Due to the nature of the assembly sequence, there will be requirements at various times to transfer power between the U.S. and Russian Segments. In the early stages, power is transferred from the FGB to the U.S. On-Orbit Segment (USOS) via two dc-to-dc converters called Russian to American Converter Units (RACUs). The RACU converts  $28.5 \pm 0.5$  Volts from the FGB power system to an output voltage of  $123 \pm 2.0$  Volts for use on the U.S. side.

Once the USOS power system is installed, the capability exists to transfer power to the Russian Segments. This is accomplished by several types of dc-to-dc converters. The FGB contains FGB-ARCU, rated at 1.3 kW, which are powered from the USOS secondary systems and operate with an input voltage of 110 to 130 Volts. Larger 1.5-kW versions are installed in the SM, called SM-ARCU, UDM, and SPP. These units have a wider input voltage range of 110 to 180 Volts so that they can accept power directly from the U.S. primary power system in later flights.



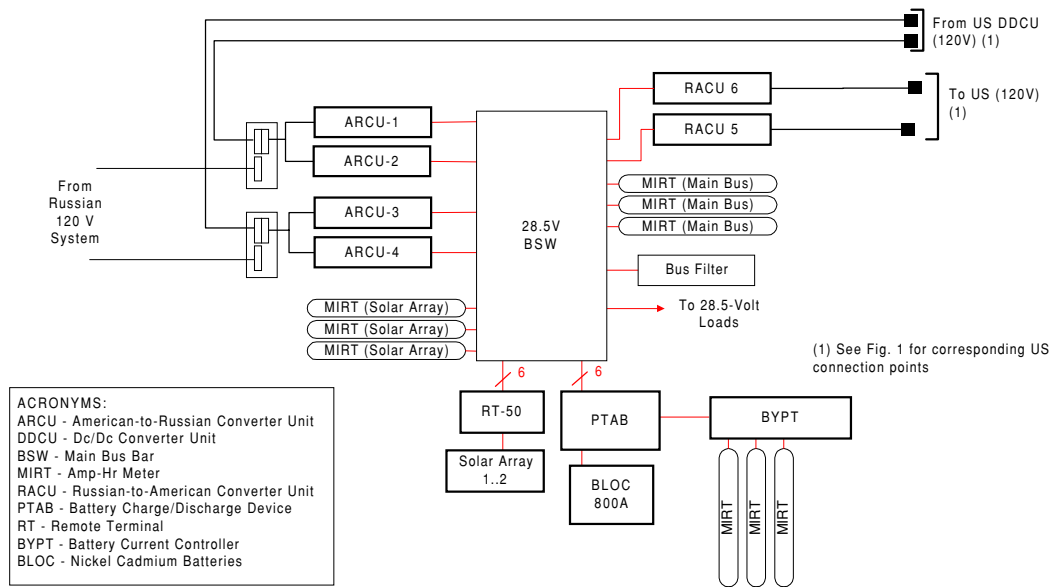

**Figure 5. FGB EPS Block Diagram**

All of the ARCUs provide an output voltage of  $28.5 \pm 0.5$  Volts when they are operating in voltage control mode. They can also operate in current control mode during certain conditions, which will be described below.

Another 1.5-kW dc-to-dc converter called the Russian DDCU, currently being designed with an input voltage range of 110 to 180 Volts, is being developed for use in the UDM and the SPP. These units will provide an output of  $120 \pm 2.0$  Volts for use on the high-voltage systems and can also operate in the current control mode.

The BSW is the main bus bar where the RT-50s, ARCUs, and PTABs are bused together. Connected directly to the BSW is the 0.6-Farad bus filter, which ensures stable operation. Also connected to the BSW are six MIRTs. Three of these provide telemetry for total bus charge (0 to 1200 Amp-hrs), and three provide total array charge (0 to 1800 Amp-hrs). When the maximum value is reached, they simply roll back to zero and begin integrating again.

The basic operation of the system will first be described with the ARCUs off. In the sun portion of the orbit, the solar arrays will provide power for both battery charging and the loads. Each unit sequentially turns on as load is increased, with the last one on, providing pulse width modulation for bus voltage regulation. In the event there is insufficient power from the arrays to supply the load and batteries, the PTABs will go into a charge reduction mode to ensure voltage regulation on the bus. When the sun sets, the PTABs transition into discharge mode to supply power to the loads with each PTAB sharing the load equally.

In the sun portion of the orbit, the solar arrays will provide power for battery charging and the loads as described above. However, if there is insufficient power from the sun to maintain the loads and battery charging, the ARCUs will begin to supply power. The ARCUs will

operate in the voltage control mode provided the load and battery charging demands are met. If the ARCUs cannot maintain the load and battery charging, then the PTABs will transition into a reduce charge mode to ensure voltage regulation on the bus. When the sun sets, depending on the number of ARCUs which are active and the size of the load, one of two actions can occur. If the load exceeds the output capability of the ARCUs, the PTABs will go into discharge mode to regulate the bus and make up for the difference in power, while the ARCUs operate in constant current mode. However, if the load is less than the ARCU total output capability, the batteries will be charged with any excess if not fully charged. Once fully charged, the ARCUs will regulate the bus and supply all load power.

## 5. FUTURE TECHNOLOGY DEVELOPMENT

The Space Station basic design is providing a platform for demonstrating new technologies in terms of scale, power, and performance, and the development of the EPS hardware is already being applied to other spacecraft designs. But also, the Station will be utilized as a test environment for future technologies. Alternate technologies being considered include the possible replacement of the silicon solar arrays with Gallium Arsenide (GaAs) panels, which could significantly increase the solar conversion efficiency. Another option is the use of lightweight concentrating arrays which focus sunlight onto a narrow strip of solar cells. As data is collected on the properties of the high-discharge-cycle nickel hydrogen batteries, future enhancements are being evaluated which could increase their capacity and extend their life.

One significant new technology, already in the development stages for the Station, is the replacement of chemical batteries with rotating flywheels to store energy during eclipse.

## Flywheel Background

As discussed above, the once fully assembled ISS power system will utilize 48 Ni-H2 battery boxes for energy storage. These Ni-H2 ORUs have a design life of 6-1/2 years. With a 15-year life of the ISS, this will necessitate a scheduled replacement of battery boxes, involving a significant recurring cost to the ISS program. National Aeronautical and Space Administration (NASA) - Glenn Research Center (GRC) intends to demonstrate the safe operation of flywheel technology which, when integrated into the U.S. power system, will provide the ISS with replacement hardware capable of the full 15-year service life, without the need for routine replacement. Thus, over the life cycle of the ISS, significant cost and launch-mass savings can be attained by eliminating periodic replacement of batteries. More information describing the flywheel development effort is given in [2].

The primary focus of the project, named Flywheel Energy Storage System (FESS) project is to extensively emphasize safe flywheel operation in ground-based ISS power system test beds prior to production of a flight system. Extensive ground tests will help to satisfy the unique safety concerns with operation of these high-speed, high-kinetic energy devices prior to implementation on the ISS.

In the near term, NASA will procure a FESS Engineering Model (EM) as a power system test demonstrator. This EM is defined as having the form, fit, and function, of a flight-quality FESS, which will provide a clear path leading to the flight design. The FESS consists of a Flywheel Control and Data Interface (FCDI) and two Flywheel Energy Storage Units (FESUs). The FESS hardware and software functionally mimic the energy storage and control of an ISS battery string that consists of a BCDU and two battery boxes. This EM Unit will undergo system-level tests at NASA-GRC prior to power system compatibility testing with the ISS EPS at the ISS Space Power Electronics Lab (SPEL) facility. Following these tests, the EM will be returned to NASA-GRC for environmental testing. With completion of this EM effort, NASA-GRC anticipates manufacturing a FESS Qualification Unit and first Flight Unit. With a successful qualification of the FESS, NASA expects to be able to procure a recurring set of FESSs for the life cycle replacement of ISS battery boxes.

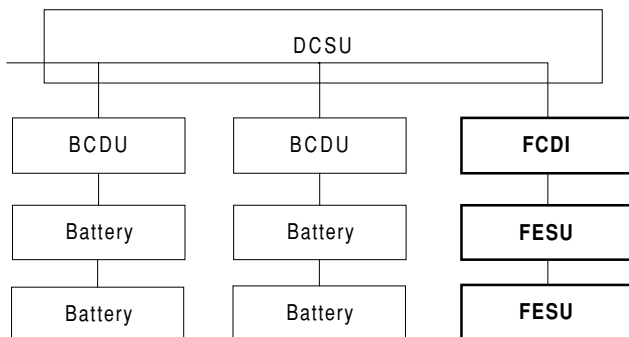

Figure 6. ISS PV Module

## Flywheel Energy Storage System Description

The FESS consists of an FCDI and two FESUs. This combination replaces a baseline BCDU and two battery boxes as shown in Figures 6 and 7.

Key power requirements for the flywheel string include the following:

|                            | ISS BCDU/<br>Battery String                           | FESS                                 |
|----------------------------|---|--------------------------------------|
| Useable Energy Storage     | 2.5 kW-hr (nominal)<br>4.3 kW-hr (full)               | 5.0 kW-Hr                            |
| Continuous Discharge Power | 4.4 kW (nominal)<br>6.3 kW (full –<br>2 battery case) | 4.4 kW (continuous)<br>5.5 kW (peak) |

### ISS PV Module

The FCDI receives commands from the ISS Photovoltaic Control Assembly (PVCA), as well as controls and monitors the health of the FESU units. The FESU receives commands from the FCDI, and receives/stores/delivers electrical power in the flywheel modules. Each FESU contains two flywheel modules and control electronics. Due to the output torque of a single flywheel, the FESU architecture uses pairs of flywheels in a counter-rotating configuration to effectively cancel out torques on the vehicle. Each flywheel module consists of the following: a composite rotor, motor/generator, magnetic bearing actuators, touchdown bearing system, rotor caging system, sensors, and housing.

During the insolation part of the orbit, the counter-rotating flywheels suspended in magnetic bearings are spun up to maximum operating speeds of 60,000 rpm (charge cycle).

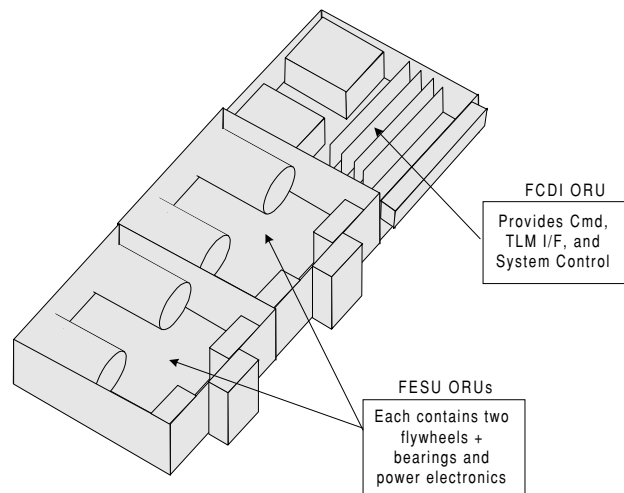

Figure 7. FESS Description

During the eclipse part of the orbit, the flywheels drive the generator, decelerating the flywheels from 60,000 to approximately 20,000 rpm to output power to the ISS primary power bus (discharge cycle).

A simplified cross-section of a flywheel module is shown in Figure 8. A full certification effort is in work to ensure the safety of personnel and the ISS in proximity with the high-speed composite flywheels. Upon successful completion of the EM effort, plans are to proceed to start qualification hardware in 2002. First flight hardware would follow in time to support the last ISS Photovoltaic Module (PVM) (Segment S6) flight, Flight 15A in 2004. Subsequent FESS replacement systems would be procured to replace the battery boxes as part of normal operations maintenance activities.

## 6. SUMMARY AND CONCLUSIONS

The power system for the ISS, now being constructed on orbit, is the largest and most adaptable space power system ever flown. It features channelized, redundant hardware for both the U.S. and Russian segments, with power transfer capabilities in both directions. Key elements of the system are already in space, and have supported astronaut crews on several assembly missions. Others are undergoing final integration testing [3]. The data from the EPS as construction continues, as well as research into new technologies, are paving the way for improvements in future spacecraft, satellites, and terrestrial applications.

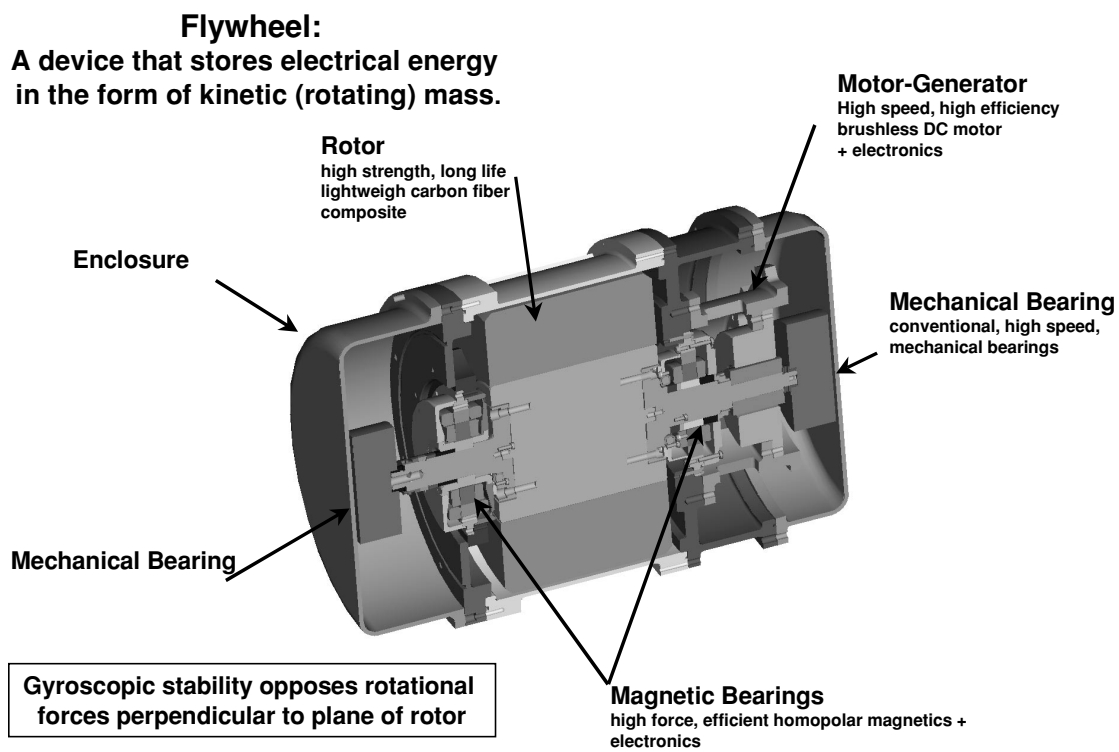

Figure 8. Cross-Section of Flywheel Module

## REFERENCES

- [1] Gholdston, E. W., Karimi, K., Lee, F. C., Rajogopalan, J., Panov, Y., Manners, B., "Stability of Large Dc Power Systems Using Switching Converters, with Application to the International Space Station", Proceedings: IECEC-96, Paper #96079, 1996
- [2] Christopher, D., Donet, Lt. C., "Flywheel Technology and Potential Benefits for Aerospace Applications", 1998 IEEE Aerospace Conference, 22 March 1998
- [3] Wilde, R. K., Aintablian, H. O., Gholdston, E. W., "International Space Station U.S. Major Element Laboratory Power Quality Test", Proceedings: IECEC-99, Paper #1999-01-2434

# REPORT DOCUMENTATION PAGE

*Form Approved*  
*OMB No. 0704-0188*

Public reporting burden for this collection of information is estimated to average 1 hour per response, including the time for reviewing instructions, searching existing data sources, gathering and maintaining the data needed, and completing and reviewing the collection of information. Send comments regarding this burden estimate or any other aspect of this collection of information, including suggestions for reducing this burden, to Washington Headquarters Services, Directorate for Information Operations and Reports, 1215 Jefferson Davis Highway, Suite 1204, Arlington, VA 22202-4302, and to the Office of Management and Budget, Paperwork Reduction Project (0704-0188), Washington, DC 20503.

|  |   |  |                                   |
|--|---|--|-----------------------------------|
| <b>1. AGENCY USE ONLY</b> ( <i>Leave blank</i> )   | <b>2. REPORT DATE</b><br>June 2000                              | <b>3. REPORT TYPE AND DATES COVERED</b><br>Technical Memorandum                  |                                   |
| <b>4. TITLE AND SUBTITLE</b><br><br>The Electric Power System of the International Space Station—A Platform for Power Technology Development   |   | <b>5. FUNDING NUMBERS</b><br><br>WU-478-29-10-00                                 |                                   |
| <b>6. AUTHOR(S)</b><br><br>Eric B. Gietl, Edward W. Gholdston, Bruce A. Manners, and Rex A. Delventhal   |   |  |                                   |
| <b>7. PERFORMING ORGANIZATION NAME(S) AND ADDRESS(ES)</b><br><br>National Aeronautics and Space Administration<br>John H. Glenn Research Center at Lewis Field<br>Cleveland, Ohio 44135-3191   |   | <b>8. PERFORMING ORGANIZATION REPORT NUMBER</b><br><br>E-12329                   |                                   |
| <b>9. SPONSORING/MONITORING AGENCY NAME(S) AND ADDRESS(ES)</b><br><br>National Aeronautics and Space Administration<br>Washington, DC 20546-0001   |   | <b>10. SPONSORING/MONITORING AGENCY REPORT NUMBER</b><br><br>NASA TM-2000-210209 |                                   |
| <b>11. SUPPLEMENTARY NOTES</b><br>Prepared for the 2000 Aerospace Conference sponsored by the Institute of Electrical and Electronics Engineers, Big Sky, Montana, March 18-25, 2000. Eric B. Gietl, Space Station Program, Boeing, 2100 Space Park Drive, Houston, Texas 77058; Edward W. Gholdston, Rocketdyne, Boeing, P.O. Box 7922, Canoga Park, California 91309-7922; Bruce A. Manners and Rex A. Delventhal, NASA Glenn Research Center. Responsible person, Bruce A. Manners, organization code 6920, (216) 433-8341.   |   |  |                                   |
| <b>12a. DISTRIBUTION/AVAILABILITY STATEMENT</b><br><br>Unclassified - Unlimited<br>Subject Category: 20<br><br>This publication is available from the NASA Center for AeroSpace Information, (301) 621-0390.   |   | <b>12b. DISTRIBUTION CODE</b>  |                                   |
| <b>13. ABSTRACT</b> ( <i>Maximum 200 words</i> )<br><br>The electrical power system developed for the International Space Station represents the largest space-based power system ever designed and, consequently, has driven some key technology aspects and operational challenges. The full U.S.-built system consists of a 160-Volt dc primary network, and a more tightly regulated 120-Volt dc secondary network. Additionally, the U.S. system interfaces with the 28-Volt system in the Russian segment. The international nature of the Station has resulted in modular converters, switchgear, outlet panels, and other components being built by different countries, with the associated interface challenges. This paper provides details of the architecture and unique hardware developed for the Space Station, and examines the opportunities it provides for further long-term space power technology development, such as concentrating solar arrays and flywheel energy storage systems. |   |  |                                   |
| <b>14. SUBJECT TERMS</b><br><br>International Space Station; Power; Flywheels  |   | <b>15. NUMBER OF PAGES</b><br>13   |                                   |
|  |   | <b>16. PRICE CODE</b><br>A03   |                                   |
| <b>17. SECURITY CLASSIFICATION OF REPORT</b><br>Unclassified   | <b>18. SECURITY CLASSIFICATION OF THIS PAGE</b><br>Unclassified | <b>19. SECURITY CLASSIFICATION OF ABSTRACT</b><br>Unclassified                   | <b>20. LIMITATION OF ABSTRACT</b> |