

**For: wpm**

**Printed on: Tue, Aug 3, 1993 15:56:36**

**From book: Allen\_Bradley\_Hardware\_Ref**

**Document: title**

**Last saved on: Tue, May 25, 1993 14:12:47**

**Document: toc**

**Last saved on: Tue, May 25, 1993 14:12:48**

**Document: AB\_Hardware\_Doc**

**Last saved on: Tue, May 25, 1993 14:12:52**

# EPICS: Allen–Bradley Hardware Reference Manual

Greg Nawrocki

<b>CHAPTER 1 Allen–Bradley 6008–SV VMEbus I/O Scanner . . . . .</b>	<b>1</b>
1.1 VMEbus 6008–SV I/O Scanner . . . . .	1
1.2 VMEbus 6008–SV I/O Scanner Strapping . . . . .	1
1.3 VMEbus 6008–SV I/O Scanner Installation . . . . .	1
1.3.1 Power Requirements . . . . .	1
1.3.2 Module Location in the VME chassis Input Output Controller (IOC) . . .	1
1.3.3 Module Insertion . . . . .	1
1.4 VMEbus 6008–SV I/O Scanner Wiring Connection . . . . .	2
1.5 VMEbus 6008–SV I/O Scanner Use . . . . .	3
<b>CHAPTER 2 Allen–Bradley Universal I/O Chassis     1771–A1B, –A2B, –A3B, and –A4B . . . . .</b>	<b>4</b>
2.1 Universal I/O Chassis . . . . .	4
2.2 Universal I/O Chassis Strapping . . . . .	4
2.3 Universal I/O Chassis Module Placement . . . . .	4
<b>CHAPTER 3 Allen–Bradley Power Supply Module 1771–P4S . . . . .</b>	<b>5</b>
3.1 1771–P4S Power Supply Module . . . . .	5
3.2 1771–P4S Power Supply Module Strapping . . . . .	5
3.3 1771–P4S Power Supply Module Installation . . . . .	5
3.3.1 Power Requirements . . . . .	5
3.3.2 Module Location in the I/O Chassis . . . . .	6
3.3.3 Module Insertion . . . . .	6
3.4 Wiring Connection . . . . .	6
3.4.1 Using Two Power Supply Modules . . . . .	6
3.5 1771–P4S Power Supply Module Use . . . . .	6
<b>CHAPTER 4 Allen–Bradley 1771–ASB Remote I/O Adapter Module . . . . .</b>	<b>8</b>
4.1 1771–ASB Remote I/O Adapter Module . . . . .	8
4.2 1771–ASB Remote I/O Adapter Module Configuration . . . . .	8
4.2.1 Setting the Module Configuration Plug(s) . . . . .	9
4.2.2 Setting the Module Switches . . . . .	9
4.2.3 Setting the Universal I/O Chassis backplane switches . . . . .	10
4.3 1771–ASB Remote I/O Adapter Module Installation . . . . .	10
4.3.1 Power Requirements . . . . .	10
4.3.2 Module Location in the I/O Chassis . . . . .	10
4.3.3 Module Keying . . . . .	11
4.3.4 Module Insertion . . . . .	11
4.4 1771–ASB Remote I/O Adapter Module Wiring Connection . . . . .	11
4.5 1771–ASB Remote I/O Adapter Module Use . . . . .	12
<b>CHAPTER 5 Allen–Bradley 1771–IFE Analog Input Module . . . . .</b>	<b>13</b>
5.1 1771–IFE Analog Input Module . . . . .	13
5.2 1771–IFE Analog Input Module Strapping . . . . .	13
5.3 1771–IFE Analog Input Module Installation . . . . .	14
5.3.1 Power Requirements . . . . .	14
5.3.2 Module Location in the I/O Chassis . . . . .	14
5.3.3 Module Keying . . . . .	14
5.3.4 Module Insertion . . . . .	14
5.4 1771–IFE Analog Input Module Wiring Connection . . . . .	15

5.5 1771–IFE Analog Input Module Use .....	15
<b>CHAPTER 6 Allen–Bradley 1771–OFE Analog Output Module ..</b>	<b>16</b>
6.1 1771–OFE Analog Output Module .....	16
6.2 1771–OFE Analog Output Module Strapping .....	16
6.3 1771–OFE Analog Output Module Installation .....	16
6.3.1 Power Requirements .....	16
6.3.2 Module Location in the I/O Chassis .....	17
6.3.3 Module Keying .....	17
6.3.4 Module Insertion .....	17
6.4 1771–OFE Analog Output Module Wiring Connection .....	18
6.5 1771–OFE Analog Output Module Use .....	18
<b>CHAPTER 7 Allen–Bradley 1771–IG(D) TTL Input Module .....</b>	<b>19</b>
7.1 1771–IG(D) TTL Input Module .....	19
7.2 1771–IG(D) TTL Input Module Strapping .....	19
7.2.1 1771–IG TTL Input Module Strapping .....	19
7.2.2 1771–IGD TTL Input Module Strapping .....	19
7.3 1771–IG(D) TTL Input Module Installation .....	20
7.3.1 Power Requirements .....	20
7.3.2 Module Location in the I/O Chassis .....	20
7.3.3 Module Keying .....	21
7.3.4 Module Insertion .....	21
7.4 1771–IG(D) TTL Input Module Wiring Connection .....	21
7.5 1771–IG(D) TTL Input Module Use .....	21
<b>CHAPTER 8 Allen–Bradley 1771–OG(D) TTL Output .....</b>	<b>23</b>
8.1 1771–OG(D) TTL Output Module .....	23
8.2 1771–OG(D) TTL Output Module Strapping .....	23
8.2.1 1771–OG TTL Output Module Strapping .....	23
8.2.2 1771–OGD TTL Output Module Strapping .....	23
8.3 1771–OG(D) TTL Output Module Installation .....	24
8.3.1 Power Requirements .....	24
8.3.2 Module Location in the I/O Chassis .....	24
8.3.3 Module Keying .....	25
8.3.4 Module Insertion .....	25
8.4 1771–OG(D) TTL Output Module Wiring Connection .....	25
8.5 1771–OG(D) TTL Output Module Use .....	25
<b>CHAPTER 9 Allen–Bradley 1771–IQ DC Selectable Input Module .....</b>	<b>27</b>
9.1 1771–IQ DC Selectable Input Module .....	27
9.2 1771–IQ DC Selectable Input Module Strapping .....	27
9.3 1771–IQ DC Selectable Input Module Installation .....	27
9.3.1 Power Requirements .....	27
9.3.2 Module Location in the I/O Chassis .....	27
9.3.3 Module Keying .....	28
9.3.4 Module Insertion .....	28
9.4 1771–IQ DC Selectable Input Module Wiring Connection .....	29
9.5 1771–IQ DC Selectable Input Module Use .....	29
<b>CHAPTER 10 Allen–Bradley 1771–OW Contact Output Module .</b>	<b>30</b>
10.1 1771–OW Contact Output Module .....	30

10.2 1771–OW Contact Output Module Strapping .....	30
10.3 1771–OW Contact Output Module Installation .....	31
10.3.1 Power Requirements .....	31
10.3.2 Module Location in the I/O Chassis .....	31
10.3.3 Module Keying .....	31
10.3.4 Module Insertion .....	31
10.4 1771–OW Contact Output Module Wiring Connection .....	31
10.5 1771–OW Contact Output Module Use .....	32
<b>CHAPTER 11 Allen–Bradley 1771–IBD DC (10–30V)</b>	
<b>Input Module .....</b>	<b>33</b>
11.1 1771–IBD DC (10–30V) Input Module .....	33
11.2 1771–IBD DC (10–30V) Input Module Strapping .....	33
11.3 1771–IBD DC (10–30V) Input Module Installation .....	33
11.3.1 Power Requirements .....	33
11.3.2 Module Location in the I/O Chassis .....	34
11.3.3 Module Keying .....	34
11.3.4 Module Insertion .....	34
11.4 1771–IBD DC (10–30V) Input Module Wiring Connection .....	34
11.5 1771–IBD DC (10–30V) Input Module Use .....	35
<b>CHAPTER 12 Allen–Bradley 1771–OBD DC (10–60V)</b>	
<b>Output Module .....</b>	<b>36</b>
12.1 1771–OBD DC (10–60V) Output Module .....	36
12.2 1771–OBD DC (10–60V) Output Module Strapping .....	36
12.3 1771–OBD DC (10–60V) Output Module Installation .....	36
12.3.1 Power Requirements .....	36
12.3.2 Module Location in the I/O Chassis .....	37
12.3.3 Module Keying .....	37
12.3.4 Module Insertion .....	37
12.4 1771–OBD DC (10–60V) Output Module Wiring Connection .....	37
12.5 1771–OBD DC (10–60V) Output Module Use .....	38
<b>CHAPTER 13 Allen–Bradley 1771–IXE Thermocouple / Millivolt</b>	
<b>Input Module .....</b>	<b>39</b>
13.1 1771–IXE Thermocouple / Millivolt Input Module .....	39
13.2 1771–IXE Thermocouple / Millivolt Input Module Strapping .....	39
13.3 1771–IXE Thermocouple / Millivolt Input Module Installation .....	39
13.3.1 Power Requirements .....	39
13.3.2 Module Location in the I/O Chassis .....	39
13.3.3 Module Keying .....	39
13.3.4 Module Insertion .....	39
13.4 1771–IXE Thermocouple / Millivolt Input Module Wiring Connection ..	40
13.5 1771–IXE Thermocouple / Millivolt Input Module Use .....	41
<b>CHAPTER 14 Allen–Bradley 2705 RediPANEL Push Button Module</b>	<b>42</b>
14.1 RediPANEL Push Button Module .....	42
14.2 RediPANEL Push Button Module Configuration .....	42
14.2.1 Setting the Module Switches .....	42
14.3 RediPANEL Push Button Module Installation .....	44
14.3.1 Power Requirements .....	44

14.3.2 Mechanical .....	44
14.4 RediPANEL Push Button Module Wiring Connection .....	44
14.5 RediPANEL Push Button Module Module Use .....	44
14.5.1 Mapping to EPICS .....	44
14.5.2 Diagnostic Indicators .....	45
14.5.3 LED and Lamp Test .....	45

## CHAPTER 1 Allen–Bradley 6008–SV VMEbus I/O Scanner

### 1.1 VMEbus 6008–SV I/O Scanner

The VMEbus I/O Scanner physically resides in a VME chassis Input Output Controller (IOC), and acts as a master for an Allen Bradley subnet in an EPICS control system. The address of the VMEbus I/O Scanner corresponds to the **LINK number** in an Allen–Bradley / EPICS subnet. Up to two VMEbus I/O Scanners (LINK 0 and LINK 1) may be used in one VME chassis IOC. In an EPICS control system, one VMEbus I/O Scanner has the ability to be the master for up to 8 Allen Bradley slave nodes, including Remote I/O Adapters in Allen Bradley 1771 Series I/O Chassis, or Allen Bradley RediPANEL Pushbutton Modules, both commonly used in an EPICS control system. In an Allen–Bradley / EPICS subnet the addresses of the slave nodes are referred to as the **ADAPTER number**.

### 1.2 VMEbus 6008–SV I/O Scanner Strapping

Refer to figure 1.1 when strapping the VMEbus I/O Scanner. J2, J6, J7, and J8 are factory mandated settings and should not be altered from their illustrated positions. J1, J4, and positions 1 – 4 of J5 are set as illustrated so that the VMEbus I/O scanner conforms to standard 24bit supervisory access data addressing, the mode used in an EPICS control system. J3, and positions 5 – 8 of J5 are set for the proper base address of a VMEbus I/O scanner in an EPICS control system. They should be inserted as illustrated in figure 1.1 with the exception of J5 position 8. This jumper should be inserted for a VMEbus I/O scanner module used as **LINK 0**, and removed for a VMEbus I/O scanner module used as **LINK 1**.

### 1.3 VMEbus 6008–SV I/O Scanner Installation

#### 1.3.1 Power Requirements

The Allen–Bradley VMEbus I/O Scanner may be installed in any VME chassis IOC. Before Installation, calculate the power requirements of the modules currently in the VME chassis IOC. Add to that **2.5A @ 5V DC**, the current required by the VMEbus I/O Scanner. Check to be sure that this combined current requirement does not exceed the current driving ability of the VME chassis IOC power supply.

#### 1.3.2 Module Location in the VME chassis Input Output Controller (IOC)

The VMEbus I/O Scanner is a 6U, double height VME board which may occupy any slot but the first slot in a VME chassis IOC, this slot is commonly occupied by the VME processor module.

#### 1.3.3 Module Insertion

Before a module is inserted into a VME chassis IOC, be sure that the power to the IOC is shut off. As always, be sure that "bringing down" this specific IOC will not have detrimental effects on any part of the control system serviced by this particular IOC. To insert the module, place it in the plastic tracks on the top and bottom of the VME chassis IOC. Slide the module into the IOC until the module comes in contact with the backplane connectors. Do

Figure 1.1

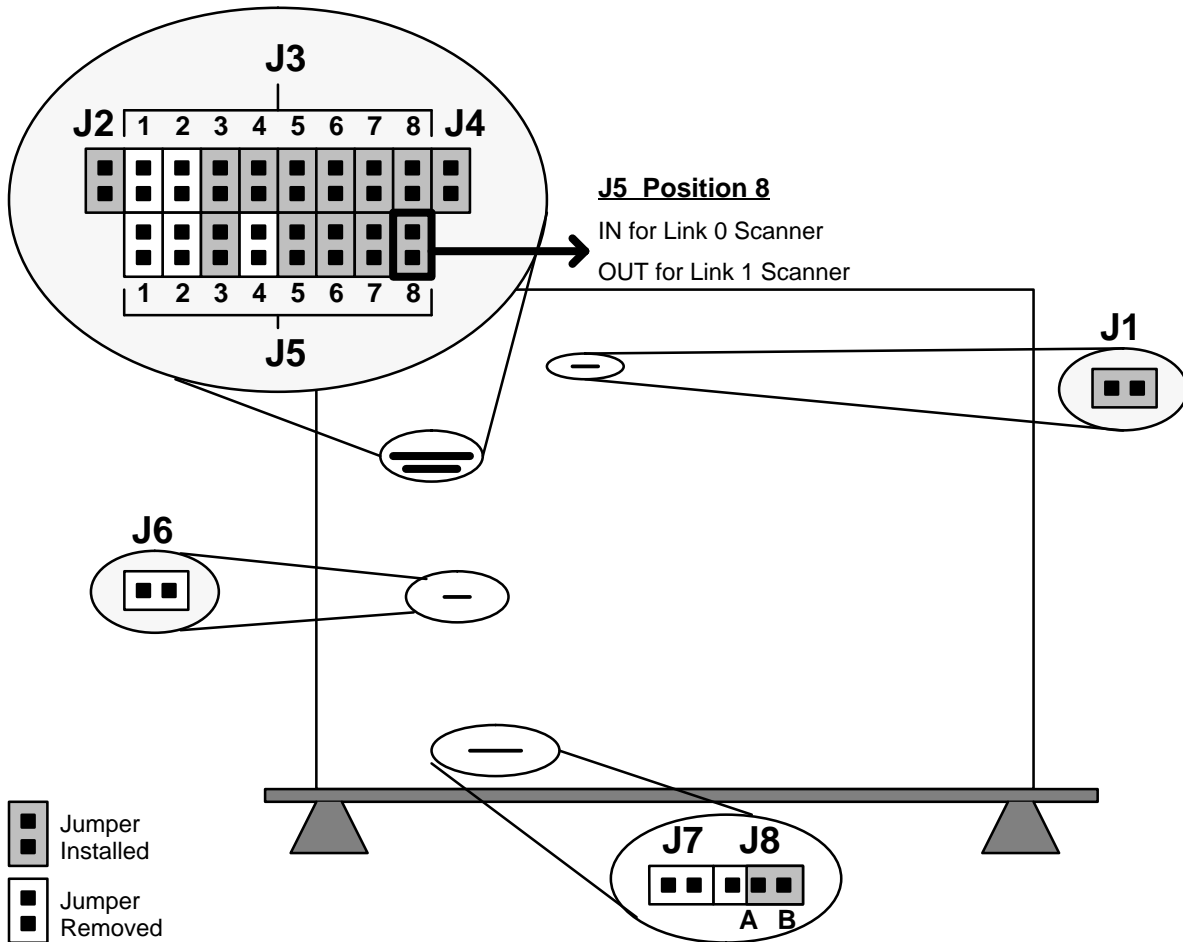

not force the module in, instead apply firm and even pressure on the module to seat it properly on the backplane connectors. Tighten the screws at the top and bottom of the face panel of the VMEbus I/O Scanner (be sure not to over-tighten) so that the I/O Scanner remains firmly in place in the VME chassis IOC.

### 1.4 VMEbus 6008–SV I/O Scanner Wiring Connection

Connection between the VMEbus I/O Scanner master, and the Allen–Bradley subnet slave modules such as the remote I/O adapters or RediPANELs should be made via shielded twin–axial cable. The use of Belden 9463 J22 304.8MTR BLUSTG is recommended. This cable has the following specifications.

- 78 OHM TWINAXIAL CABLE
- 2 CONDUCTOR
- 20 AWG (.52 sq. mm) 7x#28 (.08 sq. mm) Tinned Cu
- .0185" (.47mm) SOLID PE DIALECTRIC
- BELDFOIL 100% + Tinned Cu BRAID 57%



.032" (81mm) PVC JACKET – .243" O.D.  
 SURFACE PRINTED  
 (UL) TYPE CM  
 USE: COMMUNICATION CIRCUITS IN ACCORDANCE WITH NEC ARTICLE 800  
 AWM STYLE 2582  
 60C 150V

The VMEbus I/O Scanner should be used with the supplied connector that fits into JK1 of the VMEbus I/O Scanner. The wires should be inserted into the connector so that the corresponding connection to JK1 will appear as in figure 1.2.

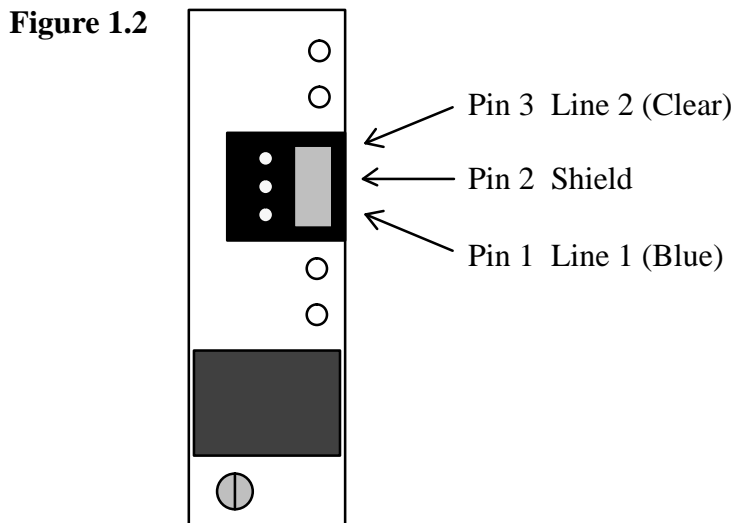

This diagram represents the bottom of the VMEbus I/O Scanner VME module.

### 1.5 VMEbus 6008-SV I/O Scanner Use

The front panel of the VMEbus I/O scanner contains four LEDs which indicate the status of the I/O Scanner. The PWR (power) LED is lighted **green** when power (5V) is applied to the module through the VME backplane. The SER COM (serial communication) LED is lighted **solid green** when the scanner is able to communicate with all of its slaves, **flashes green** when able to communicate with some of its slaves, and is out when unable to communicate with any of its slaves. The BPLN COM (backplane communication) LED lights **green** for half a second when a VMEbus access is made to the VMEbus I/O Scanner. The FLT (fault) LED lights **red** when the VMEbus I/O scanner is reset, performing a self test, or a fault has been detected.

## **CHAPTER 2 Allen–Bradley Universal I/O Chassis 1771–A1B, –A2B, –A3B, and –A4B**

### **2.1 Universal I/O Chassis**

The Allen–Bradley Universal I/O Chassis provide backplane connections for the 1771 series I/O modules, a 1771–ASB Remote I/O Adapter Module, and a combination of 1771 power supply modules. The chassis come in four sizes, the –A1B chassis has 4 slots, the –A2B chassis has 8 slots, the –A3B has 12 slots, and the –A4B has 16 slots.

### **2.2 Universal I/O Chassis Strapping**

The Universal I/O Chassis contains a backplane switch assembly located on the left hand, lower side of the backplane as you look into the chassis. Refer the the section on the Allen–Bradley 1771–ASB Remote I/O Adapter Module for instructions on the setting of these switches. There is also a power supply configuration jumper located along the top of the backplane as you look into the chassis. This jumper should be set to the right position if an external power supply is used, and set to the **left** position (most common in an EPICS control system) if a power supply module such as the 1771–P4S Power Supply Module is used.

### **2.3 Universal I/O Chassis Module Placement**

The Allen–Bradley 1771–ASB Remote I/O Adapter Module must reside in the left most slot of the I/O chassis. Other restrictions to 1771 series module placement may apply, these will be mentioned on a per–module basis.

## CHAPTER 3 Allen–Bradley Power Supply Module 1771–P4S

### 3.1 1771–P4S Power Supply Module

The 1771–P4S Power Supply Module is a 5V, 8A power supply that can be used in the 1771–A1B, –A2B, –A3B, and –A4B Universal I/O Chassis. Up to two of these supplies may be used as dictated by the power requirements of the 1771 series I/O modules contained in the Universal I/O Chassis. If two supplies are used, they must be connected by a Power Supply Paralleling Cable.

### 3.2 1771–P4S Power Supply Module Strapping

Place the module so that the right hand cover plate (the one with the labels) is facing down on a flat surface, and the front of the module is facing away from you. The module should appear as it does in figure 3.1 with the two configuration jumpers just behind the gold connecting traces of the circuit board. These jumpers select the proper voltage regulation for the different power supply configurations. The right position (rarely used in an EPICS control system) selects the configuration for a single power supply in a power supply chassis, connected to an I/O chassis through a power supply cable. In an EPICS control system, they should be configured as they appear in figure 3.1, with both of the jumpers located on the left hand side of the three pin headers.

**Figure 3.1**

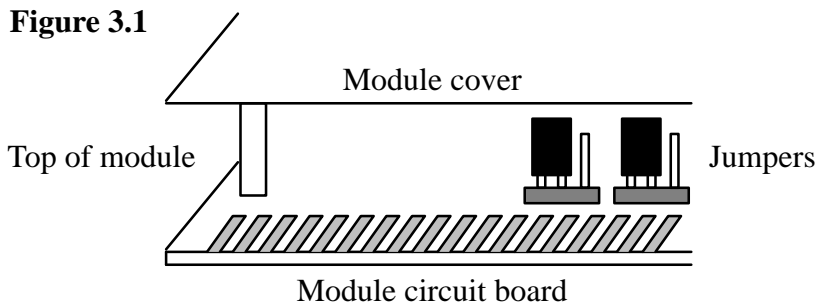

### 3.3 1771–P4S Power Supply Module Installation

#### 3.3.1 Power Requirements

The Allen–Bradley 1771–P4S Power Supply Module may be installed in any Allen–Bradley Universal I/O Chassis, 1771–A1B, 1771–A2B, 1771–A3B, or 1771–A4B. Each module supplies a maximum of **8A** to the other modules in the I/O crate. Two of these modules may be used per I/O chassis to supply a maximum of **16A** to the other modules in the chassis. Adding the current requirements of all of the modules in the I/O chassis will indicate if two power supply modules are needed, or if one will suffice.

The Allen–Bradley 1771–P4S Power Supply Module itself requires 120V AC (actual voltage input range is 97 – 132 VAC rms) at a frequency of 47 – 63 Hz. The module is protected with a 1.5A 250V Slow–blow fuse located on the front panel.

### 3.3.2 Module Location in the I/O Chassis

The Allen–Bradley 1771–P4S Power Supply Module may be placed in any slot of the I/O chassis with the exception of the extreme left slot. This slot is occupied by the Remote I/O Adapter Module. It is suggested that the power supply modules be placed away from analog input modules and low voltage DC modules to minimize electrical noise interference.

### 3.3.3 Module Insertion

Before a power supply module is inserted into the Universal I/O Chassis, be sure that the power switch is in the off position, and that the 120VAC cable is disconnected from the module. If a Remote I/O Adapter is currently in the Universal I/O Chassis, this procedure can be done without shutting off the IOC that the Universal I/O Chassis is connected to, and without removing the subnet communication link. To insert the module, place it in the plastic tracks on the top and bottom of the Universal I/O Chassis. Slide the module into the Universal I/O Chassis until the module comes in contact with the backplane connector. Do not force the module in, instead apply firm and even pressure on the module to seat it properly on the backplane connector. Snap the chassis latch over the top of the module and connect the 120VAC connector to the module. The Universal I/O Chassis should begin communicating with the host IOC when the power is switched on, no rebooting of the IOC will have to be done.

## 3.4 Wiring Connection

Connection of the 120VAC power to the 1771–P4S is accomplished through the use of a Wago 231–205/000–008 connector (Allen–Bradley part number 941274–05) included with each 1771–P4S. Figure 3.2 illustrates how the 120VAC power should be connected to the 1771–P4S modules. Note that two modules are illustrated in figure 3.2, only one power supply module may be needed depending upon the current requirements of the modules in the Universal I/O Chassis.

### 3.4.1 Using Two Power Supply Modules

If two power supply modules are used in one Universal I/O Chassis they must be linked together through the Power Supply Paralleling Cable, Allen–Bradley part number 1771–CT. This connection is a communication link between the two supplies. If one of the supplies has to shut down, it informs the second supply to turn off its P/S ACTIVE indicator. If this shut down procedure does occur, the Remote I/O Adapter will be disabled, however, the second supply will continue to supply power until its DC output limits are exceeded. Because the Remote I/O Adapter will be disabled if either of two power supply modules shut down, placing two power supplies in one Universal I/O Chassis does not provide redundancy. The Power Supply Paralleling Cable should be looped over the top of the I/O chassis to avoid picking up signals induced from the I/O wiring.

## 3.5 1771–P4S Power Supply Module Use

The 1771–P4S is used by simply turning on the power switch located on the front of the module. If two supplies are being used, turn them on simultaneously, otherwise the first supply powered on may shut down due to an over–current condition. Remember to shut the supply, or supplies down when inserting or removing any module from the Universal I/O Chassis.

**Figure 3.2**

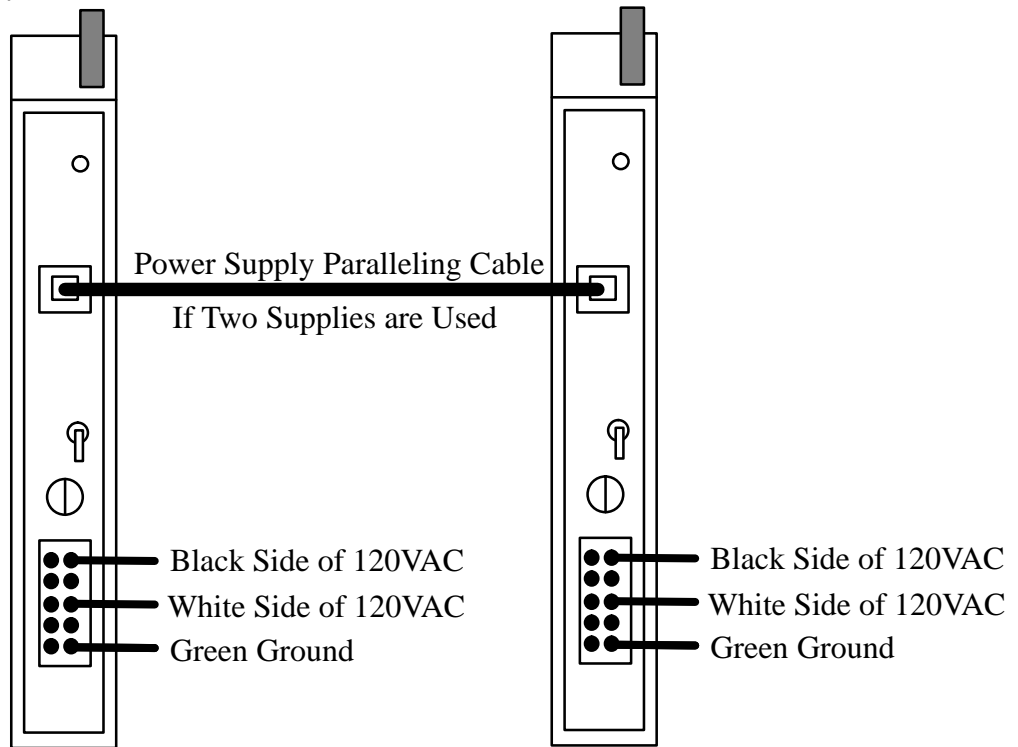

The front of the 1771-P4S contains a P/S ACTIVE (power supply active) indicator. If the indicator is illuminated **green**, the power supply, and any supply connected to it through a power supply paralleling cable is operating normally. Note that this does not guarantee that the power supply is correctly inserted and supplying power to the backplane. If the indicator is off the power supply module has detected one of the following conditions: DC over-voltage, DC under-voltage, DC over-current, power switch turned off, AC under-voltage, or that any power supply module connected to it through a power supply paralleling cable has detected a similar condition.

## CHAPTER 4 Allen–Bradley 1771–ASB Remote I/O Adapter Module

### 4.1 1771–ASB Remote I/O Adapter Module

The Allen–Bradley 1771–ASB Remote I/O Adapter Module physically resides in a Universal I/O Chassis, and acts as a slave in an Allen Bradley subnet in an EPICS control system. The 1771–ASB Remote I/O Adapters are linked via subnet connection to other Remote I/O Adapters in Allen Bradley 1771 Series I/O Chassis, Allen–Bradley RediPANEL Pushbutton Modules, and back to a VMEbus I/O scanner. They correspond to the **ADAPTER number** when configuring an Allen–Bradley subnet. An Allen–Bradley / EPICS subnet allows for up to 8 adapters to be located on one Allen–Bradley subnet link.

### 4.2 1771–ASB Remote I/O Adapter Module Configuration

Refer to figure 4.1 for the following instructions. There are three steps involved in the configuration of a 1771–ASB Remote I/O Adapter Module, the first involves the setting of the Module Configuration Plug or Plugs, the second involves the setting of the Module Switches, and the third involves the setting of the Universal I/O Chassis backplane switches located on the left hand, lower side of the backplane as you look into the chassis. Note that there are two styles of Remote I/O Adapter, they are easily discerned by looking at SW 2. In the older style module SW 2 is a 4 position DIP switch, in the newer style, SW 2 is a 6 position DIP switch.

**Figure 4.1**

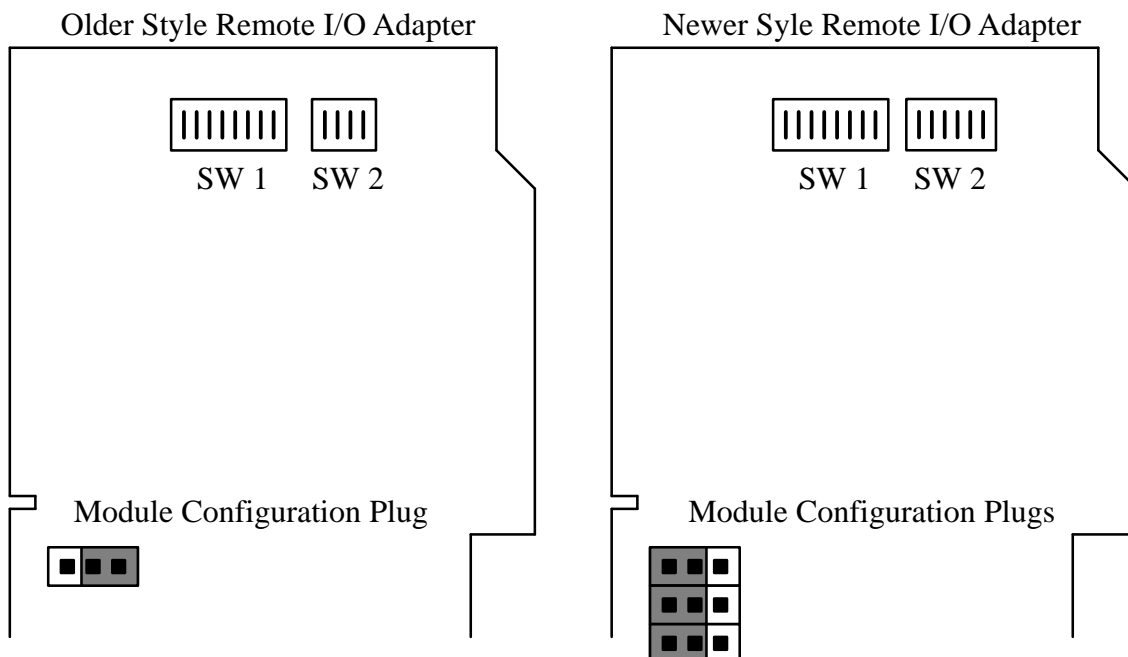

### 4.2.1 Setting the Module Configuration Plug(s)

If you have the older style Remote I/O Adapter begin by laying the module on its right side (label side down). Remove the left cover by removing the 4 screws. Locate the configuration plug and place the jumper in the right most position as indicated in figure 4.1. Replace the cover and secure the 4 screws.

If you have the newer style Remote I/O Adapter, access to the Module Configuration Plugs can be gained through a small access hole in the lower left corner of the left cover of the module. Place all three jumpers in the left most position as indicated in figure 4.1.

In either of the above cases the Remote I/O Adapter module is placed in a mode for use with 32–point I/O modules and any address method. This is the configuration used in an EPICS control system. Note that in this mode you may not use the 1771–IX or the 1771–IY modules.

### 4.2.2 Setting the Module Switches

S1 is the Address Switch Assembly in both the newer and older style Remote I/O adapters. Switches 1 – 6 select the Universal I/O Chassis adapter number. Observe figure 4.2 for the proper address settings, when the switches are closed (ON) this corresponds to a binary 0 in the adapter address, and when the switches are open (OFF) this corresponds to a binary 1 in the adapter address. Note that switches 1 – 3 must always remain in their closed (ON) positions as the EPICS control system only uses adapter addresses 0 – 7.

**Figure 4.2**

I/O Adapter Number	Switch Number		
	4	5	6
0	On	On	On
1	On	On	Off
2	On	Off	On
3	On	Off	Off
4	Off	On	On
5	Off	On	Off
6	Off	Off	On
7	Off	Off	Off

Switches 7 and 8 should remain in the closed (ON) position as this will place the Remote I/O adapter in the 1st I/O group number 0, used in the EPICS control system.

S2 sets the baud rate and other configurations. For both the older and newer style of Remote I/O Adapter switch number 1 should be closed (ON), and switch number 2 should be open (OFF) this sets the baud rate at 57.6K baud and allows for a link distance of 10,000ft over twisted pair cable. This is the preferred setting for an EPICS control system. Switch number 3 should remain open (OFF) as it is not used, and switch number 4 should remain open (OFF) to put the Remote I/O adapter in scanning mode for all slots.

If you have the newer style Remote I/O Adapter switch number 5 should be open (OFF) for unrestricted emulation, and switch number 6 should be open (OFF) as it is not used. A summary of switch positions is available in figure 4.3.

**Figure 4.3**

S1 Switch Number								S2 Switch Number					
1	2	3	4	5	6	7	8	1	2	3	4	5	6
On	On	On	Figure 4.2			On	On	On	Off	Off	Off	Off	Off

On = Closed

Off = Open

Ignore S2–5 and S2–6 for older style Remote I/O Adapter

### 4.2.3 Setting the Universal I/O Chassis backplane switches

The Allen–Bradley Universal I/O Chassis contains a backplane switch assembly located on the left hand, lower side of the backplane as you look into the chassis. The switches are labeled 1 – 8, with switch 1 on the top, and switch 8 on the bottom.

**Switch 1** is the Last State Switch. When closed (ON) outputs from the chassis will remain in the last state when a fault is detected. When open (OFF) the outputs will be de–energized when a fault is detected. The common EPICS setting for this switch is **closed (ON)**.

**Switch 2** is the Processor Restart Switch. When closed (ON) the processor has the ability to restart the chassis. When open (OFF) the chassis must be restarted at the chassis. The common EPICS setting for this switch is **closed (ON)**.

**Switch 3** and **Switch 4** are not used, and should always remain **open (OFF)**.

**Switch 5** and **Switch 6** should always remain **open (OFF)** to select 2 slot addressing.

**Switch 7** is not used, and should always remain **open (OFF)**.

**Switch 8** is the Last Chassis Switch. When closed (ON) the chassis is not the last chassis of a single ADAPTER number. When open (OFF) the chassis is the only chassis associated with a single ADAPTER number. The common EPICS setting for this switch is **open (OFF)**.

## 4.3 1771–ASB Remote I/O Adapter Module Installation

### 4.3.1 Power Requirements

The Allen–Bradley 1771–ASB Remote I/O Adapter Module may be installed in any Allen–Bradley Universal I/O Chassis, 1771–A1B, 1771–A2B, 1771–A3B, or 1771–A4B. Before Installation, calculate the power requirements of the modules currently in the chassis. Add to that **1.2A @ 5V DC**, the current required by the 1771–ASB. Check to be sure that this combined current requirement does not exceed the current driving ability of the chassis power supply combination.

### 4.3.2 Module Location in the I/O Chassis

The 171–ASB must be placed in the extreme left slot of the Universal I/O Chassis. It is suggested that this module be placed away from AC modules or high voltage DC modules to minimize electrical noise interference.



### 4.3.3 Module Keying

The Allen Bradley Universal I/O chassis have the ability to limit the slot access to certain modules by the implementation of a keying system. Modules are slotted in two places at the edge of the circuit board. The position of the keying bands on the backplane connector of the I/O chassis must correspond to these slots. To key a slot for use by the 1771–ASB Remote I/O Adapter only (this would in the case of the 1771–ASB be the left most slot), place the keying bands between **54** and **56** and between **16** and **18** on the I/O chassis backplane connector.

### 4.3.4 Module Insertion

Before a module is inserted into the Universal I/O Chassis, be sure that the power to the chassis is shut off. This can be done without shutting off the IOC that the Universal I/O Chassis is connected to. To insert the module, place it in the plastic tracks on the top and bottom of the Universal I/O Chassis. Slide the module into the Universal I/O Chassis until the module comes in contact with the backplane connector. Do not force the module in, instead apply firm and even pressure on the module to seat it properly on the backplane connector. Snap the chassis latch over the top of the module and connect the wiring arm to the module. The Universal I/O Chassis should begin communicating with the host IOC when power is reapplied, no rebooting of the IOC will have to be done.

## 4.4 1771–ASB Remote I/O Adapter Module Wiring Connection

Connection of analog signals to the 1771–ASB are accomplished through the use of the wiring arm. Signals should be connected to the screw terminals on the wiring arm, as detailed in figure 4.4, and the wiring arm should be connected to the front tab connector on the 1771–ASB. If the 1771–ASB is the last adapter on a link, or the only adapter on a link, be sure to add the I/O Channel terminator, Allen–Bradley Catalog # 1770–XT to the wiring arm.

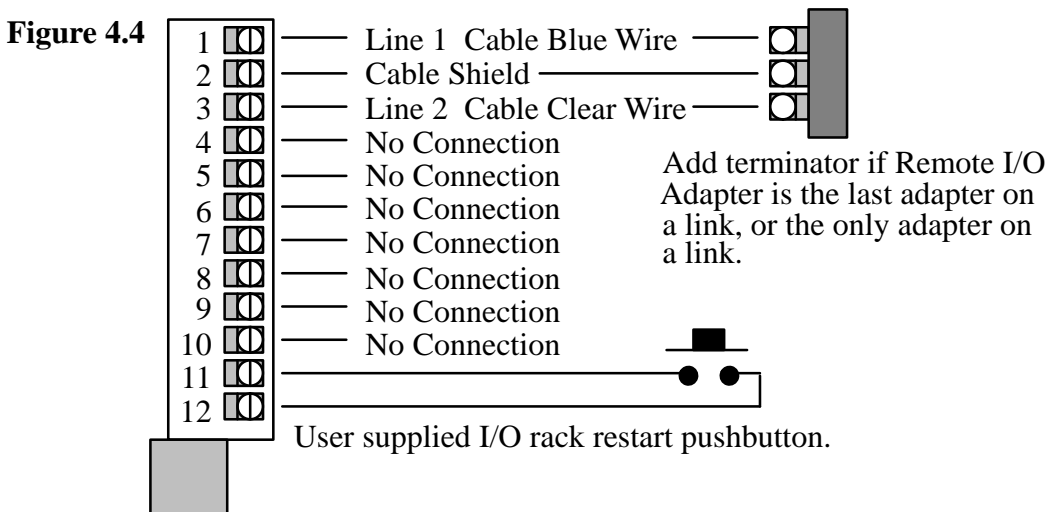

## 4.5 1771–ASB Remote I/O Adapter Module Use

The front panel of the 1771–ASB contains a **green** ACTIVE, a **red** ADAPTER FAULT, and a **red** I/O RACK FAULT indicator. During normal operation the ACTIVE indicator should be illuminated, and the other two indicators should be out. The possible combinations of indicator actions are listed in figure 4.5.

**Figure 4.5**

ACTIVE	ADAPTER FAULT	I/O RACK FAULT	INDICATION
On	Off	Off	Normal Operation
Off	On	Off	Watchdog timeout – Module fault
On	Blink	Off	Module placement error
Blink in unison		Off	Incorrect starting I/O group number
On	On	On	Module not communicating
Off	On	On	Module not communicating
Blink	Off	Off	Remote Adapter not controlling I/O
Sequence on/off – top to bottom			Module not communicating
Blink alternately		Off	Remote Adapter not controlling I/O
Off	Off	On	I/O chassis fault – No communication link
Blink	Off	On	Communication on link, possible shorted backplane
Blink	On	Off	Module identification line fault
Off	Off	Off	Module not communicating

## CHAPTER 5 Allen–Bradley 1771–IFE Analog Input Module

### 5.1 1771–IFE Analog Input Module

The 1771–IFE senses up to 16 single–ended or 8 differential analog inputs and converts them to a proportional 12 bit binary value. Its use with the EPICS control system supports 3 voltage ranges and 1 current range, selectable on a per channel basis. Supported input ranges include:

Voltages	Currents
0 to 5V DC (differential)	4 to 20mA (differential)
–10 to 10V DC (single ended)	
–10 to 10V DC (differential)	

### 5.2 1771–IFE Analog Input Module Strapping

Remove the module’s left hand cover plate (the one without the labels). Observe the location of the configuration jumpers in figure 5.1, and note the location of the individual channels.

**Figure 5.1**

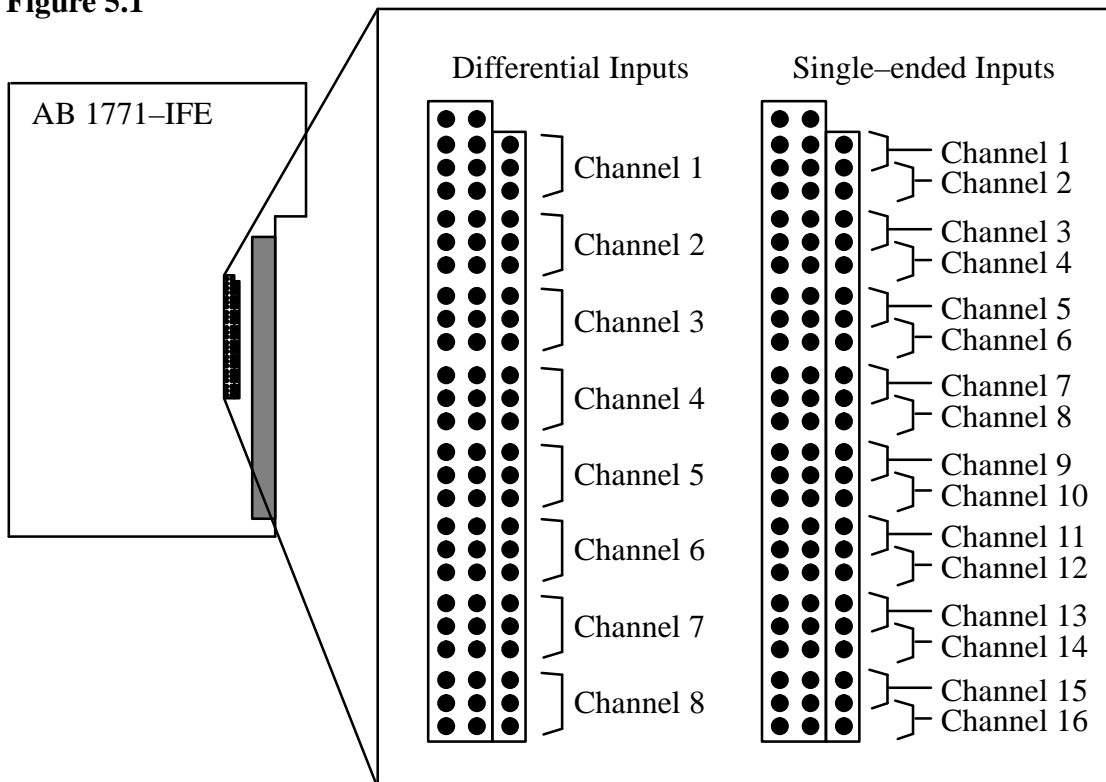

The input range is determined in software, however the single–ended or differential determination, as well as the type of input, voltage or current, is configured by the above jumpers. Figure 5.2 contains diagrams detailing this information. Refer to figure 5.1 for channel clarification.

**Figure 5.2**

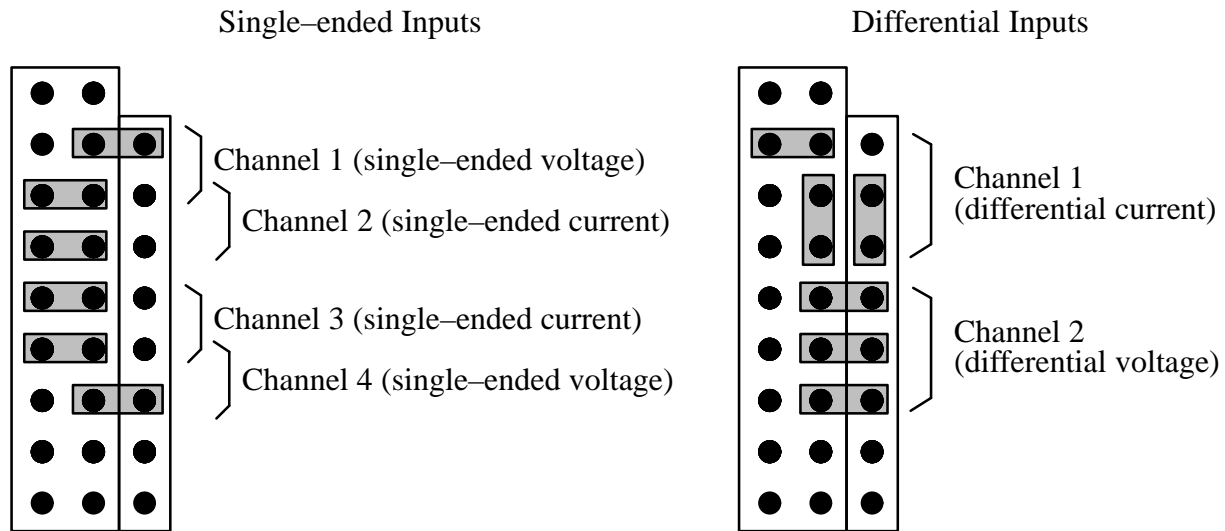

Note that this illustration details only the top few jumper points

### 5.3 1771–IFE Analog Input Module Installation

#### 5.3.1 Power Requirements

The Allen–Bradley 1771–IFE Analog Input Module may be installed in any Allen–Bradley Universal I/O Chassis, 1771–A1B, 1771–A2B, 1771–A3B, or 1771–A4B. Before Installation, calculate the power requirements of the modules currently in the chassis. Add to that **750mA @ 5V DC**, the current required by the 1771–IFE. Check to be sure that this combined current requirement does not exceed the current driving ability of the chassis power supply.

#### 5.3.2 Module Location in the I/O Chassis

The 1771–IFE may be placed in any slot of the I/O chassis with the exception of the extreme left slot. This slot is occupied by the Remote I/O Adapter Module. It is suggested that analog input modules and low voltage DC modules be placed away from AC modules or high voltage DC modules to minimize electrical noise interference.

#### 5.3.3 Module Keying

The Allen Bradley Universal I/O chassis have the ability to limit the slot access to certain modules by the implementation of a keying system. Modules are slotted in two places at the edge of the circuit board. The position of the keying bands on the backplane connector of the I/O chassis must correspond to these slots. To key a slot for use by the 1771–IFE Analog Input only, place the keying bands between **10** and **12** and between **24** and **26** on the I/O chassis backplane connector.

#### 5.3.4 Module Insertion

Before a module is inserted into the Universal I/O Chassis, be sure that the power to the chassis is shut off. This can be done without shutting off the IOC that the Universal I/O Chassis is connected to, and without removing the subnet communication link. To insert the module, place it in the plastic tracks on the top and bottom of the Universal I/O Chassis. Slide the

module into the Universal I/O Chassis until the module comes in contact with the backplane connector. Do not force the module in, instead apply firm and even pressure on the module to seat it properly on the backplane connector. Snap the chassis latch over the top of the module and connect the wiring arm to the module. The Universal I/O Chassis should begin communicating with the host IOC when power is reapplied, no rebooting of the IOC will have to be done.

### 5.4 1771–IFE Analog Input Module Wiring Connection

Connection of analog signals to the 1771–IFE is accomplished through the use of the wiring arm. Signals should be connected to the screw terminals on the wiring arm, as detailed in figure 5.3, and the wiring arm should be connected to the front tab connector on the 1771–IFE. The recommend cable length for voltage signals is 50ft. This is based on considerations of signal degradation and electrical noise immunity in typical industrial environments. When shielded cable is used and grounding of the shield is desired, it is recommended that the connection be made at one of the I/O chassis mounting bolts. To prevent ground loops only one end of the cable shield should be grounded.

**Figure 5.3**

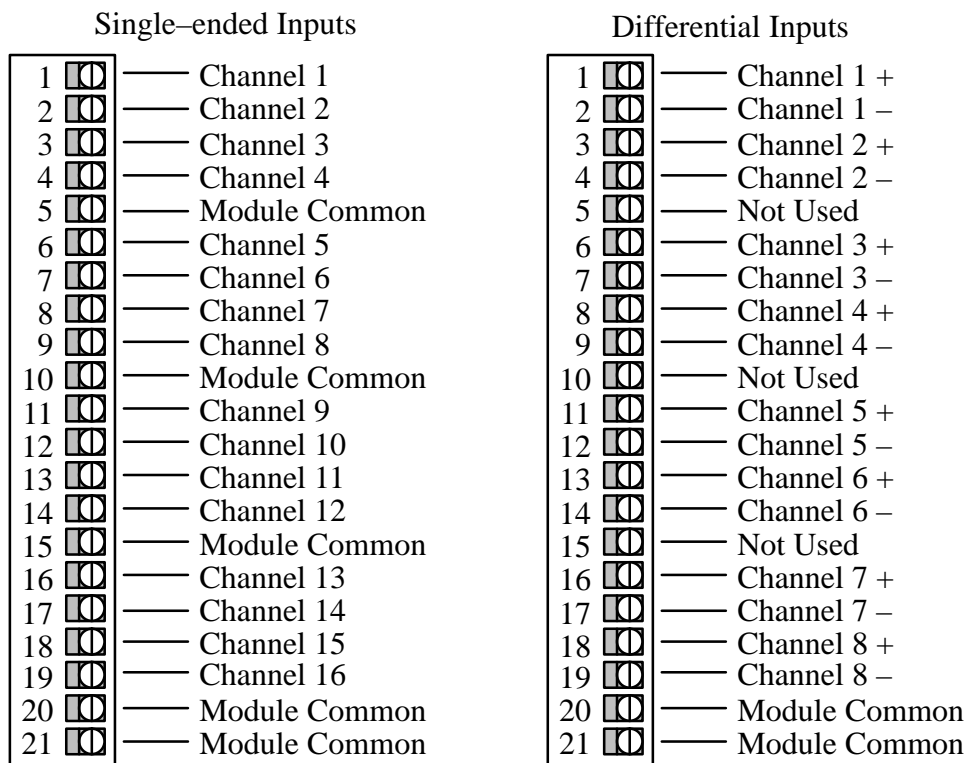

### 5.5 1771–IFE Analog Input Module Use

The front panel of the 1771–IFE contains a **green** RUN and a **red** FAULT indicator. At power up an initial module self-check occurs. If there is no fault the **red** indicator will turn off. The **green** indicator will flash until the processor communicates successfully with the module.

## CHAPTER 6 Allen–Bradley 1771–OFE Analog Output Module

### 6.1 1771–OFE Analog Output Module

The 1771–OFE is an intelligent block transfer module that converts binary or four digit BCD values to analog signals. The 1771–OFE controls four differential voltage or current outputs. The module is available in two versions, the 1771–OFE1 for voltage outputs, and the 1771–OFE2 for current outputs. Its use with the EPICS control system supports 1 current range, and 3 voltage ranges, the voltage ranges are selectable on a per channel basis. Supported input ranges include:

Voltages	Currents
1771–OFE1	1771–OFE2
1 to 5V DC	4 to 20mA
0 to 10V DC	
–10 to 10V DC	

The output specifications for the voltage ranges dictate a maximum of 10mA per channel. The output specifications for the current ranges dictate a maximum of 1200 ohms per channel of load resistance.

### 6.2 1771–OFE Analog Output Module Strapping

Both the 1771–OFE1 (voltage output module) and the 1771–OFE2 (current output module) have a configuration strap for the test mode output level. Only the 1771–OFE1 (voltage output module) requires the configuration of module straps for the individual channel ranges, the 1771–OFE2 (current output module) has no such jumpers. Remove the module's right hand cover plate (the one with the labels) by removing the four screws on that side. This will expose the bottom side of the printed circuit board and three more screws which must be removed for complete circuit board removal. Observe the location of the configuration jumpers in figure 6.1, and note the location of the individual channels.

The Test Mode Output jumper (1771–OFE1 and 1771–OFE2) controls the magnitude of the outputs if the module should receive a reset condition from the control system. For instance, if a module output is set for a 0 to 10V DC range, and the Test Mode Output is set to MID, if the module resets, the output will be forced to 5V DC. If no jumpers are placed on the Test Mode Output configuration plug, the module will default to MID. Note that if Switch 1 of the DIP switch assembly on the Universal I/O chassis is set closed (ON), the module's outputs will remain in their last state ignoring the Test Mode Output Jumper.

The Range selection jumpers (1771–OFE1 only) are set individually for each channel according to the range desired as illustrated in figure 6.1.

### 6.3 1771–OFE Analog Output Module Installation

#### 6.3.1 Power Requirements

The Allen–Bradley 1771–OFE Analog Output Module may be installed in any Allen–Bradley Universal I/O Chassis, 1771–A1B, 1771–A2B, 1771–A3B, or 1771–A4B. Before Installation, calculate the power requirements of the modules currently in the chassis. Add to that **1.5A @ 5V DC**, the current required by the 1771–OFE. Check to be sure that this

**Figure 6.1**

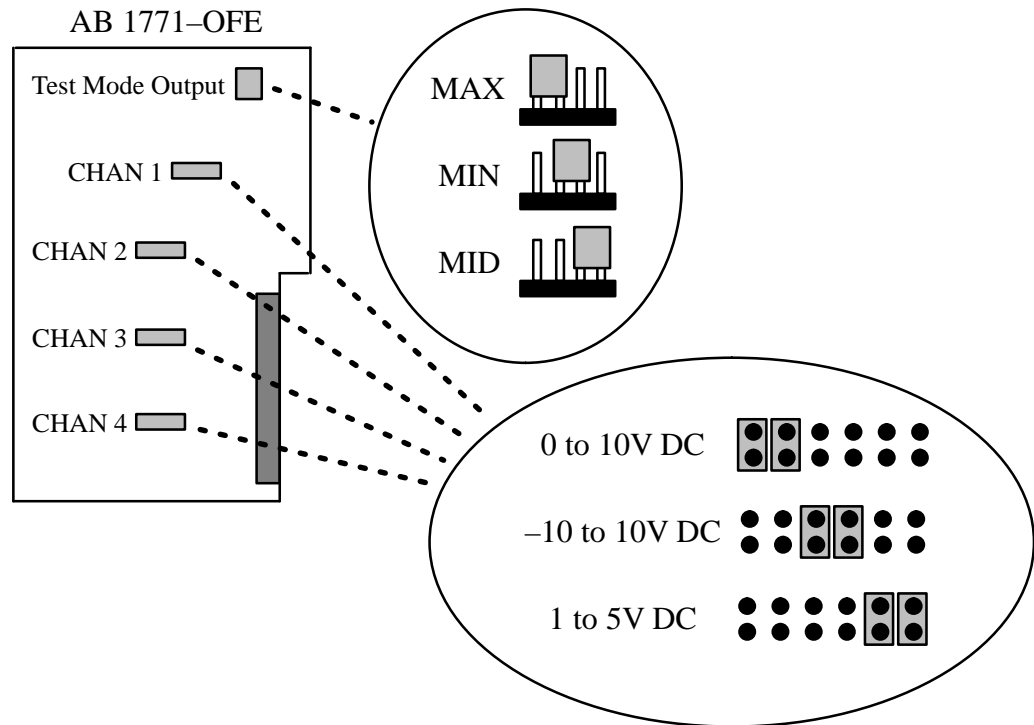

combined current requirement does not exceed the current driving ability of the chassis power supply.

### 6.3.2 Module Location in the I/O Chassis

The 1771–OFE may be placed in any slot of the I/O chassis with the exception of the extreme left slot. This slot is occupied by the Remote I/O Adapter Module. It is suggested that analog input modules and low voltage DC modules be placed away from AC modules or high voltage DC modules to minimize electrical noise interference.

### 6.3.3 Module Keying

The Allen Bradley Universal I/O chassis have the ability to limit the slot access to certain modules by the implementation of a keying system. Modules are slotted in two places at the edge of the circuit board. The position of the keying bands on the backplane connector of the I/O chassis must correspond to these slots. To key a slot for use by the 1771–OFE Analog Output only, place the keying bands between **10** and **12** and between **26** and **28** on the I/O chassis backplane connector.

### 6.3.4 Module Insertion

Before a module is inserted into the Universal I/O Chassis, be sure that the power to the chassis is shut off. This can be done without shutting off the IOC that the Universal I/O Chassis is connected to, and without removing the subnet communication link. To insert the module, place it in the plastic tracks on the top and bottom of the Universal I/O Chassis. Slide the module into the Universal I/O Chassis until the module comes in contact with the backplane connector. Do not force the module in, instead apply firm and even pressure on the module

to seat it properly on the backplane connector. Snap the chassis latch over the top of the module and connect the wiring arm to the module. The Universal I/O Chassis should begin communicating with the host IOC when power is reapplied, no rebooting of the IOC will have to be done.

### 6.4 1771–OFE Analog Output Module Wiring Connection

Connection to the analog signals of the 1771–OFE is accomplished through the use of the wiring arm. Signals should be connected to the screw terminals on the wiring arm, as detailed in figure 6.2, and the wiring arm should be connected to the front tab connector on the 1771–OFE. The recommend cable length for voltage signals is 50ft. This is based on considerations of signal degradation and electrical noise immunity in typical industrial environments. When shielded cable is used and grounding of the shield is desired, it is recommended that the connection be made at one of the I/O chassis mounting bolts. To prevent ground loops only the chassis end of the cable shield should be grounded.

**Figure 6.2**

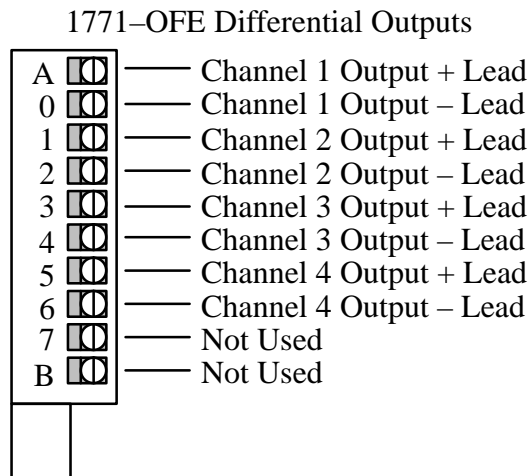

### 6.5 1771–OFE Analog Output Module Use

The front panel of the 1771–OFE contains a **green** RUN and a **red** FAULT indicator. At power up the **green** indicator will light and remain on. At power up an initial module self–check occurs. If a fault is found initially or occurs later, the **red** indicator will turn on.



## CHAPTER 7 Allen–Bradley 1771–IG(D) TTL Input Module

### 7.1 1771–IG(D) TTL Input Module

Allen–Bradley has two versions of the TTL compatible discrete Input modules that will interface to TTL output devices. The 1771–IG module will monitor eight TTL inputs while the 1771–IGD will monitor up to 16 inputs. Only the 1771–IG version has a 1ms input filter, while the 1771–IGD version has input diode protection to +5 volts and ground. The TTL voltage ranges are 0 – 0.5V DC for V low, and 2.7 – 5.25V DC for V high. The modules are current rated at I in low, 7mA source current (the device connected to the module must be able to sink this current and any current from pull up resistors), and I in high, 0.8mA (the module will sink this much current).

### 7.2 1771–IG(D) TTL Input Module Strapping

#### 7.2.1 1771–IG TTL Input Module Strapping

Remove the module’s left hand cover plate (the one without the labels). Observe the location of the configuration switches in figure 7.1. When selecting POSITIVE logic, switch 1 and

Figure 7.1

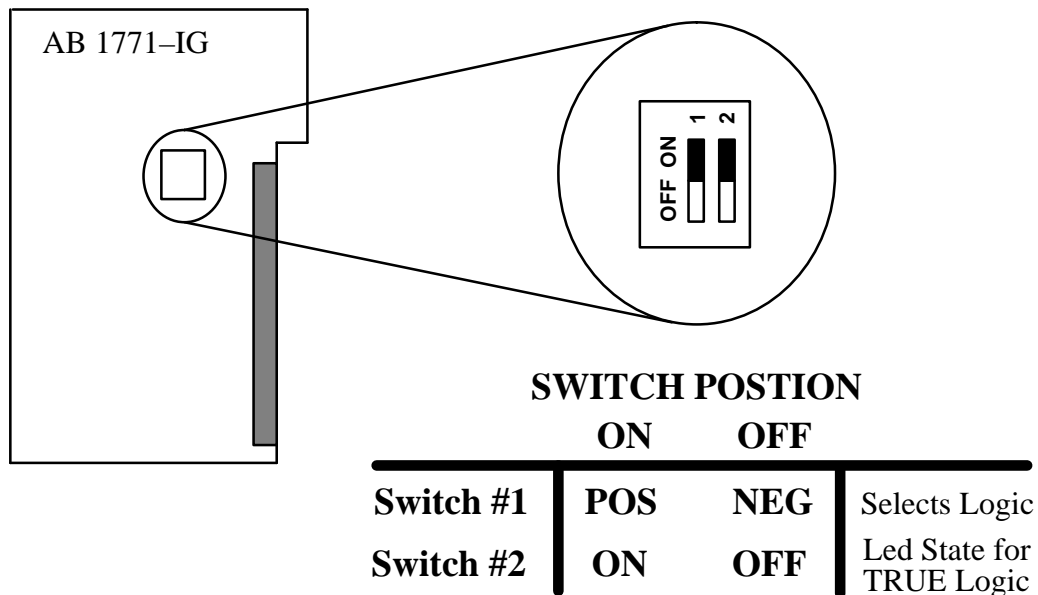

2 are generally set to the ON position. For NEGATIVE logic, switch 1 and 2 are generally set to the OFF position.

#### 7.2.2 1771–IGD TTL Input Module Strapping

Remove the module’s left hand cover plate (the one without the labels). Observe the location of the jumper figure 7.2. When selecting POSITIVE logic, set the jumper to the HIGH (left/rear) position. For NEGATIVE logic, set the jumper to the LOW (right/front) position.

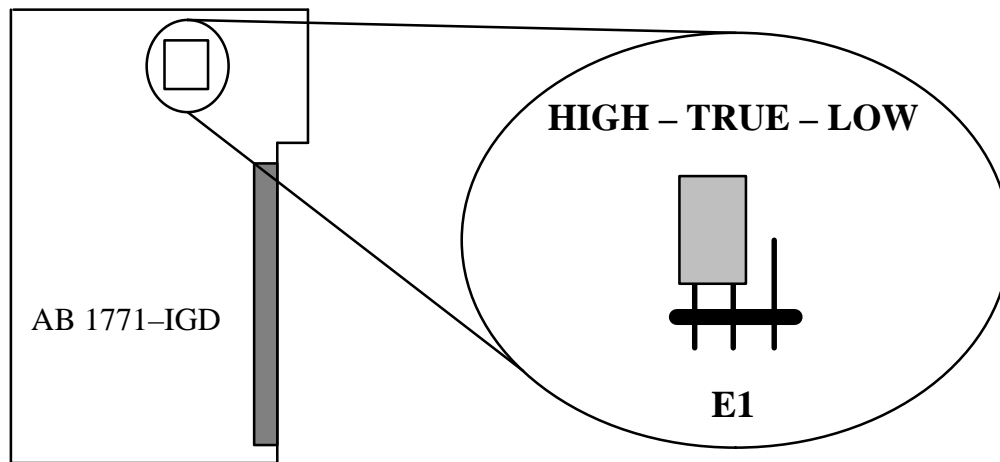
**Figure 7.2**

## 7.3 1771-IG(D) TTL Input Module Installation

### 7.3.1 Power Requirements

The Allen–Bradley 1771-IG(D) TTL Input Module may be installed in any Allen–Bradley Universal I/O Chassis, 1771-A1B, 1771-A2B, 1771-A3B, or 1771-A4B. Before installation, calculate the power requirements of the modules currently in the chassis. Add to that **122mA @ 5V DC** for the 1771-IG, or **50mA @ 5V DC** for the 1771-IGD. Check to be sure that this combined current requirement does not exceed the current driving ability of the chassis power supply.

Only the 1771-IGD module has a fuse to protect the +5V DC power supply and the module's input terminals from the accidental application of voltage that could cause damage: voltage over 6.0V DC, reverse DC or AC voltage. Fuse rating: 0.5A at 250V, use Littelfuse 312.250 or similar.

The 1771-IG is not fuse protected so care must be taken to properly connect the power supply. Accidental application of AC, reverse DC, or over voltage could damage the module.

### 7.3.2 Module Location in the I/O Chassis

The 1771-IG(D) may be placed in any slot of the I/O chassis with the exception of of the extreme left slot. This slot is occupied by the Remote I/O Adapter Module. It is suggested that analog input modules and low voltage DC modules be placed away from AC modules or high voltage DC modules to minimize electrical noise interference.

The 1771-IGD has an additional restriction. EPICS software reads and writes the Allen–Bradley chassis in Two–slot addressing mode. A module group is considered to contain two Allen–Bradley slots. The first module group address is located at slot 0 and 1. The second is slot 2 and 3 and so on. When using a 16-bit **input** module in a two–slot addressing mode, the **input** module must always be inserted into an **even** number slot (left–hand side of the module group). A complementary **output** module (8–bit or 16–bit module) may be inserted into an **odd** number slot (right–hand side of the module group) completing the module group. If no complementary module is used then that slot must remain empty.

The 1771–IG has no such restriction. An 8–bit input module can be used with any 8–bit input or output module. There is no defined order as to which input or output module is inserted in a module group, and two inputs or two outputs can be used in the same module group. However, it is common practice when using an 8–bit input and an 8–bit output module in a module group, to insert the **input** module into the **even (left–hand)** slot and the **output** module into the **odd (right hand)** slot of the module group.

### 7.3.3 Module Keying

The Allen Bradley Universal I/O chassis have the ability to limit the slot access to certain modules by the implementation of a keying system. Modules are slotted in two places at the edge of the circuit board. The position of the keying bands on the backplane connector of the I/O chassis must correspond to these slots. To key a slot for use by the 1771–IG TTL Input only, place the keying bands between **4** and **6** and between **34** and **36** on the I/O chassis backplane connector. To key a slot for use by the 1771–IGD TTL Input only, place the keying bands between **16** and **18** and between **24** and **26** on the I/O chassis backplane connector.

### 7.3.4 Module Insertion

Before a module is inserted into the Universal I/O Chassis, be sure that the power to the chassis is shut off. This can be done without shutting off the IOC that the Universal I/O Chassis is connected to, and without removing the subnet communication link. To insert the module, place it in the plastic tracks on the top and bottom of the Universal I/O Chassis. Slide the module into the Universal I/O Chassis until the module comes in contact with the backplane connector. Do not force the module in, instead apply firm and even pressure on the module to seat it properly on the backplane connector. Snap the chassis latch over the top of the module and connect the wiring arm to the module. The Universal I/O Chassis should begin communicating with the host IOC when power is reapplied, no rebooting of the IOC will have to be done.

## 7.4 1771–IG(D) TTL Input Module Wiring Connection

Connecting field wiring to the 1771–IG(D) is accomplished through the use of a shielded cable to the wiring arm. Signals should be connected to the screw terminals on the wiring arm, as detailed in figure 7.3, and the wiring arm should be connected to the front tab connector on the 1771–IG(D). When shielded cable is used and grounding of the shield is desired, it is recommended that the connection be made at one of the I/O chassis mounting bolts. To prevent ground loops only the chassis end of the cable shield should be grounded.

## 7.5 1771–IG(D) TTL Input Module Use

The front panel on the 1771–IG contains nine **red** LED indicators. The top **red** LED labeled HIGH–TRUE indicates the module is selected for positive logic when illuminating. The next eight LEDs will indicate if an individual input is true.

The front panel on the 1771–IGD contains 18 LED indicators. The top **green** LED labeled ACTIVE indicates the module is connected to +5 volts and the fuse on the 1771–IGD is not blown. The next 16 **red** LED indicators, labeled 00 through 17 (octal), will indicate if an input is true. The last **green** LED labeled HIGH indicates the module is selected for positive logic when illuminating.

**Figure 7.3**

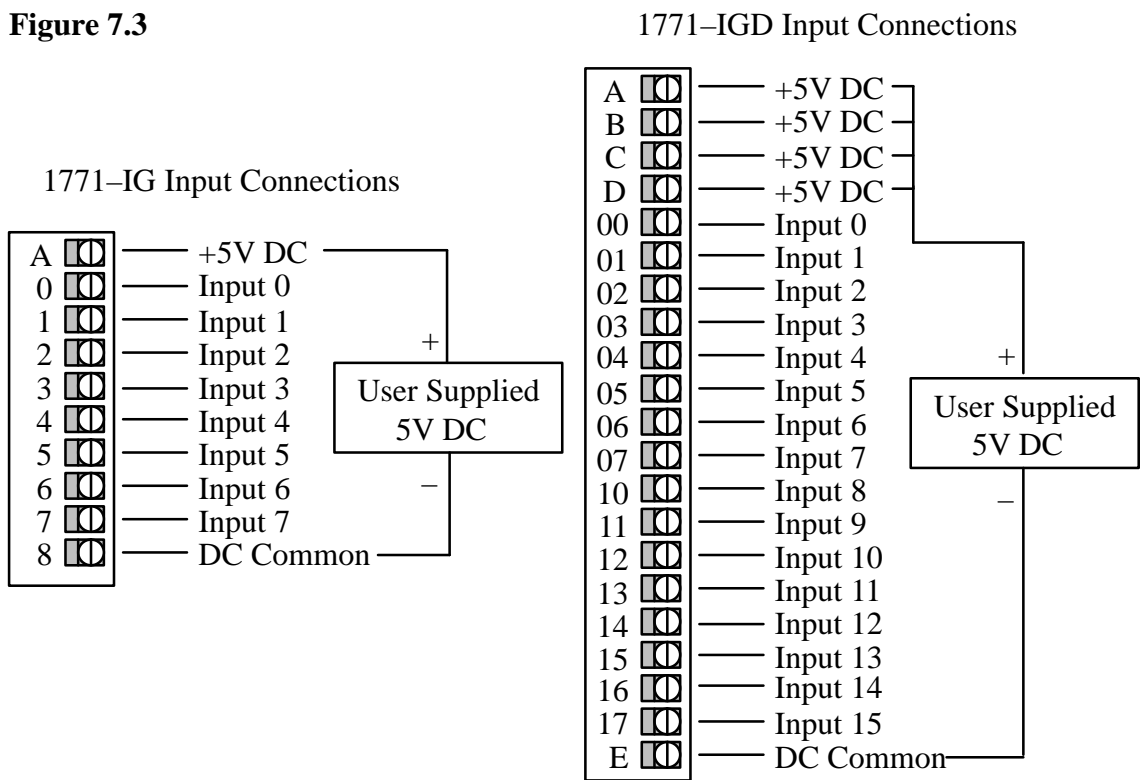

## CHAPTER 8 Allen–Bradley 1771–OG(D) TTL Output

### 8.1 1771–OG(D) TTL Output Module

Allen–Bradley has two versions of the TTL compatible discrete Output modules that will interface to TTL output devices. The 1771–OG module will control eight TTL outputs while the 1771–OGD will control up to 16 outputs. Only the 1771–OG version has a 1ms output filter, while the 1771–OGD version has output diode protection to +5 volts and ground. The TTL voltage ranges are 0–0.5V DC for V low, and 2.7–5.25V DC for V high. The modules are current rated at I out low, 20mA sink current (the device connected to the module must source no more than this amount), and I out high, 1mA (the module will source this much current).

### 8.2 1771–OG(D) TTL Output Module Strapping

#### 8.2.1 1771–OG TTL Output Module Strapping

Remove the module’s left hand cover plate (the one without the labels). Observe the location of the configuration switches in figure 7.1. When selecting POSITIVE logic, switch 1 and

Figure 7.1

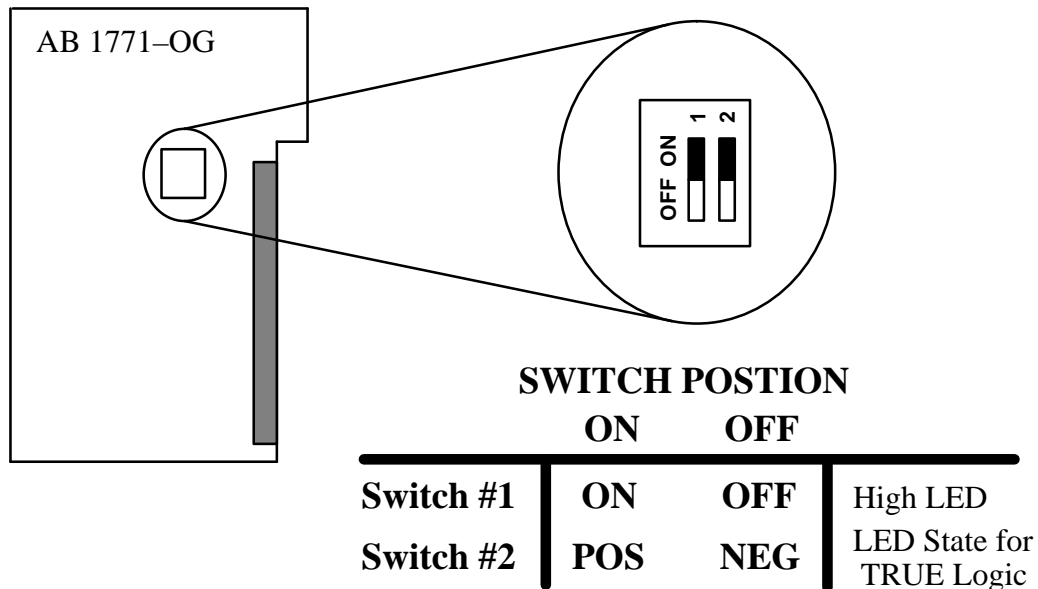

2 are set to the ON position. For NEGATIVE logic, switch 1 and 2 are generally set to the OFF position.

#### 8.2.2 1771–OGD TTL Output Module Strapping

Remove the module’s left hand cover plate (the one without the labels). Observe the location of the configuration switches figure 7.2 When selecting POSITIVE logic, set strap to the HIGH (right/front) position. For NEGATIVE logic, set strap to the LOW (left/rear) position.

Figure 7.2

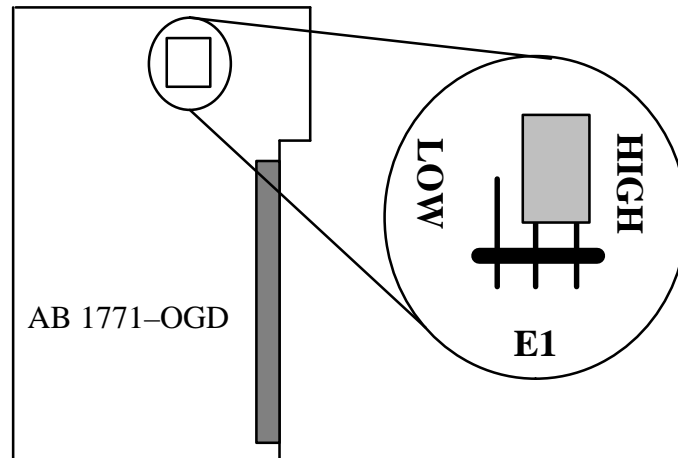

### 8.3 1771-OG(D) TTL Output Module Installation

#### 8.3.1 Power Requirements

The Allen–Bradley 1771-OG(D) TTL Output Module may be installed in any Allen–Bradley Universal I/O Chassis, 1771-A1B, 1771-A2B, 1771-A3B, or 1771-A4B. Before Installation, calculate the power requirements of the modules currently in the chassis. Add to that **168mA @ 5V DC** for the 1771-OG, or **230mA @ 5V DC** for the 1771-OGD. Check to be sure that this combined current requirement does not exceed the current driving ability of the chassis power supply.

Only the 1771-OGD module has a fuse to protect the +5V DC power supply and the module's output terminals from the accidental application of voltage that could cause damage, such as voltage over 6.0V DC, reverse DC or AC voltage. Fuse rating: 0.5A at 250V, use Littelfuse 312.250 or similar.

The 1771-OG is not fuse protected so care must be taken to properly connect the power supply. Accidental application of AC, reverse DC, or over voltage could damage the module.

#### 8.3.2 Module Location in the I/O Chassis

The 1771-OG(D) may be placed in any slot of the I/O chassis with the exception of the extreme left slot. This slot is occupied by the Remote I/O Adapter Module. It is suggested that analog input modules and low voltage DC modules be placed away from AC modules or high voltage DC modules to minimize electrical noise interference.

The 1771-OGD has an additional restriction. EPICS software reads and writes the Allen–Bradley chassis in Two-slot addressing mode. A module group is considered to contain two Allen–Bradley slots. The first module group address is located at slot 0 and 1. The second is slot 2 and 3 and so on. When using a 16-bit **output** module in a two-slot addressing mode, the output module must always be inserted into an **odd** number slot (right-hand side of the module group). A complementary **input** module (8-bit or 16-bit module) may be inserted into an **even** number (left-hand side of the module group) slot completing the module group. If no complementary module is used then that slot must remain empty.

The 1771–IG has no such restriction. An 8–bit output module can be used with any 8–bit input or output module. There is no defined order as to which input or output module is inserted in a module group, and two inputs or two outputs can be used in the same module group. However, it is common practice when using an 8–bit output and an 8–bit input module in a module group, to insert the **output** module into the **odd (right–hand)** slot and the **input** module into the **even (left–hand)** slot of the module group.

### 8.3.3 Module Keying

The Allen Bradley Universal I/O chassis have the ability to limit the slot access to certain modules by the implementation of a keying system. Modules are slotted in two places at the edge of the circuit board. The position of the keying bands on the backplane connector of the I/O chassis must correspond to these slots. To key a slot for use by the 1771–OG TTL Output only, place the keying bands between **6** and **8** and between **10** and **12** on the I/O chassis backplane connector. To key a slot for use by the 1771–OGD TTL Output only, place the keying bands between **16** and **18** and between **26** and **28** on the I/O chassis backplane connector.

### 8.3.4 Module Insertion

Before a module is inserted into the Universal I/O Chassis, be sure that the power to the chassis is shut off. This can be done without shutting off the IOC that the Universal I/O Chassis is connected to, and without removing the subnet communication link. To insert the module, place it in the plastic tracks on the top and bottom of the Universal I/O Chassis. Slide the module into the Universal I/O Chassis until the module comes in contact with the backplane connector. Do not force the module in, instead apply firm and even pressure on the module to seat it properly on the backplane connector. Snap the chassis latch over the top of the module and connect the wiring arm to the module. The Universal I/O Chassis should begin communicating with the host IOC when power is reapplied, no rebooting of the IOC will have to be done.

## 8.4 1771–OG(D) TTL Output Module Wiring Connection

Connecting field wiring to the 1771–OG(D) is accomplished through the use of a shielded cable to the wiring arm. Signals should be connected to the screw terminals on the wiring arm, as detailed in figure 8.3, and the wiring arm should be connected to the front tab connector on the 1771–OG(D). When shielded cable is used and grounding of the shield is desired, it is recommended that the connection be made at one of the I/O chassis mounting bolts. To prevent ground loops only the chassis end of the cable shield should be grounded.

## 8.5 1771–OG(D) TTL Output Module Use

The front panel on the 1771–OG contains nine **red** LED indicators. The top **red** LED labeled HIGH–TRUE indicates the module is selected for positive logic when illuminating. The next eight LEDs will indicate if an output is true.

The front panel on the 1771–OGD contains 18 LED indicators. The top **green** LED labeled ACTIVE indicates the module is connected to +5 volts and the fuse on the 1771–OGD is not blown. The next 16 **red** LED indicators, labeled 00 through 17 (octal), will indicate if an output is true. The last **green** LED labeled HIGH indicates the module is selected for positive logic when illuminating.

**Figure 8.3**

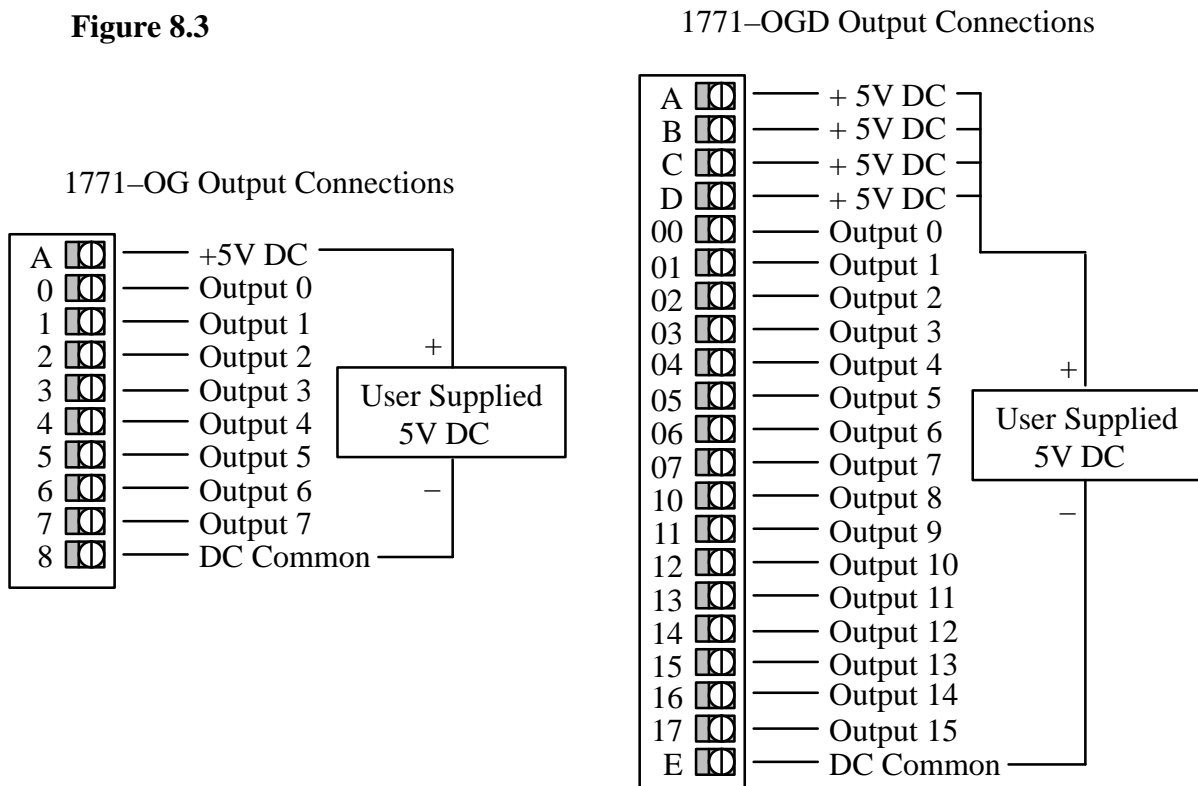



## CHAPTER 9 Allen–Bradley 1771–IQ DC Selectable Input Module

### 9.1 1771–IQ DC Selectable Input Module

The 1771–IQ DC (5–30V) Input module accepts DC voltage levels on all 8 inputs and converts these signals to logic levels. Each input circuit is individually selectable for current source (current flowing from the 1771–IQ to the DC input device) or current sink capability (current flowing from the DC input device to the 1771–IQ). This module may also be configured from either HIGH TRUE or LOW TRUE logic with an input delay of 1ms maximum or 12ms typical. For the HIGH TRUE setting TRUE is any voltage greater than 40% of the external supply voltage, and LOW is any voltage less than 20% of the external supply voltage. For the LOW TRUE setting, HIGH is any voltage less than 20% of the external supply voltage, and LOW is any voltage greater than 40% of the external supply voltage. The nominal input current per channel for an ON condition is 5mA for 5V DC, and 25mA for 30V DC. The external supply voltage power supply must be able to provide 100mA per module at 5V DC, and 350mA per module at 30V DC.

### 9.2 1771–IQ DC Selectable Input Module Strapping

Remove the module's left hand cover plate (the one without the labels). Observe the location of the configuration switches below, and note the location of the individual channels as illustrated in figure 9.1. Switch bank SW–1 is used to configure the input delay, and the true level of the logic. Figure 9.1 contains sufficient information to describe these switch settings. Switch bank SW–2 and SW–3 are used to configure each input individually for either current sink or current source. For current sink set SW–2 to the ON position and SW–3 to the OFF position for the appropriate input signal (switch 1 corresponds to signal 0, and switch 8 corresponds to signal 7). For current source set SW–2 to the OFF position and SW–3 to the ON position for the appropriate input signal (switch 1 corresponds to signal 0, and switch 8 corresponds to signal 7). Note: setting an individual channel's SW–2 and SW–3 switch to either both on. or both off is an invalid setting.

### 9.3 1771–IQ DC Selectable Input Module Installation

#### 9.3.1 Power Requirements

The Allen–Bradley 1771–IQ Contact Output Module may be installed in any Allen–Bradley Universal I/O Chassis, 1771–A1B, 1771–A2B, 1771–A3B, or 1771–A4B. Before Installation, calculate the power requirements of the modules currently in the chassis. Add to that **150mA @ 5V DC**, the current required by the 1771–IQ. Check to be sure that this combined current requirement does not exceed the current driving ability of the chassis power supply.

#### 9.3.2 Module Location in the I/O Chassis

The 1771–IQ may be placed in any slot of the I/O chassis with the exception of the extreme left slot. This slot is occupied by the Remote I/O Adapter Module. It is suggested that analog input modules and low voltage DC modules be placed away from AC modules or high voltage DC modules to minimize electrical noise interference.

**Figure 9.1**

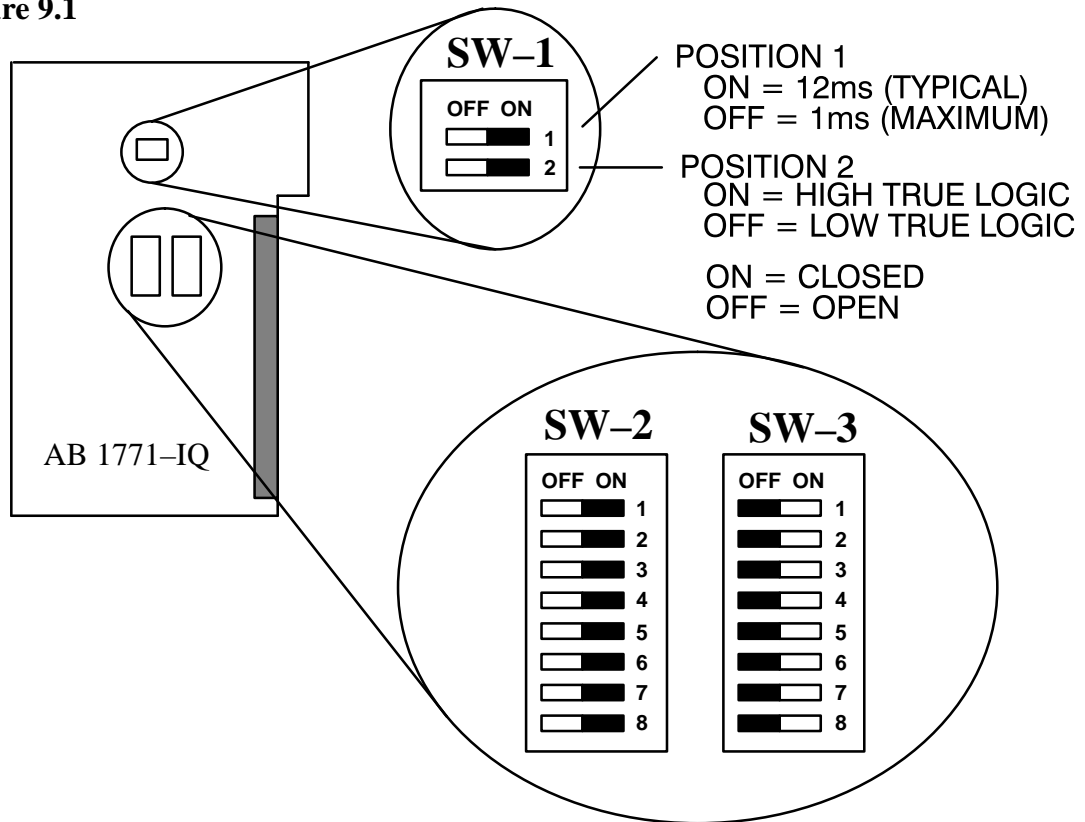

### 9.3.3 Module Keying

The Allen Bradley Universal I/O chassis have the ability to limit the slot access to certain modules by the implementation of a keying system. Modules are slotted in two places at the edge of the circuit board. The position of the keying bands on the backplane connector of the I/O chassis must correspond to these slots. To key a slot for use by the 1771-IQ Contact Output only, place the keying bands between **6** and **8** and between **24** and **26** on the I/O chassis backplane connector.

### 9.3.4 Module Insertion

Before a module is inserted into the Universal I/O Chassis, be sure that the power to the chassis is shut off. This can be done without shutting off the IOC that the Universal I/O Chassis is connected to, and without removing the subnet communication link. To insert the module, place it in the plastic tracks on the top and bottom of the Universal I/O Chassis. Slide the module into the Universal I/O Chassis until the module comes in contact with the backplane connector. Do not force the module in, instead apply firm and even pressure on the module to seat it properly on the backplane connector. Snap the chassis latch over the top of the module and connect the wiring arm to the module. The Universal I/O Chassis should begin communicating with the host IOC when power is reapplied, no rebooting of the IOC will have to be done.

### 9.4 1771–IQ DC Selectable Input Module Wiring Connection

Connecting field wiring to the 1771–IQ is accomplished through the use of the wiring arm. Signals should be connected to the screw terminals of the wiring arm, as detailed in figure 9.2, and the wiring arm should be connected to the front tab connector on the 1771–IQ. When shielded cable is used and grounding of the shield is desired, it is recommended that the connection be made at one of the I/O chassis mounting bolts. To prevent ground loops only one end of the cable shield should be grounded.

**Figure 9.2**

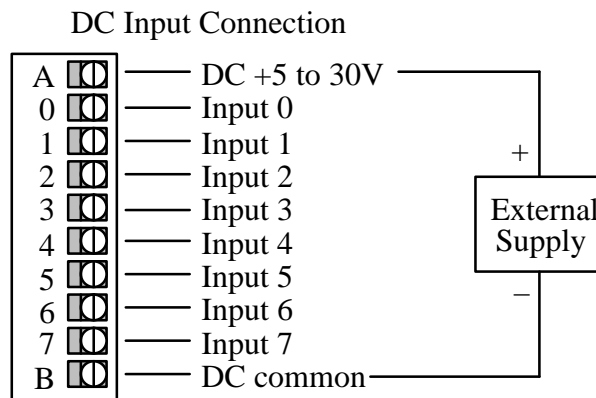

### 9.5 1771–IQ DC Selectable Input Module Use

The front panel of the 1771–IQ contains eight **red** status indicators. Each of these indicators corresponds to a single circuit within the module. When the input to a specific circuit is TRUE (whether the module is selected for HIGH TRUE or LOW TRUE logic), its corresponding status indicator will illuminate. The top LED will indicate the status of signal 0, while the bottom LED will indicate the status of signal 7.

## CHAPTER 10 Allen–Bradley 1771–OW Contact Output Module

### 10.1 1771–OW Contact Output Module

The 1771–OW controls eight relay contact outputs by sending the proper 8–bit data value to the module. The relay contacts can be set for either N.O. (normally–open) or N.C. (normally–closed) configurations. The 1771–OW does not contain any surge limiting circuitry and is recommended to be used in resistive loads only, not inductive or capacitive loads. The contacts are rated at 24 – 138V AC rms, and 24 – 125V DC, 1A per channel. The minimum contact load is 10mA at 24V DC and 10mA at 24V AC.

### 10.2 1771–OW Contact Output Module Strapping

Remove the module’s left hand cover plate (the one without the labels). Observe the location of the configuration jumpers in figure 10.1, and note the location of the individual channels.

Figure 10.1

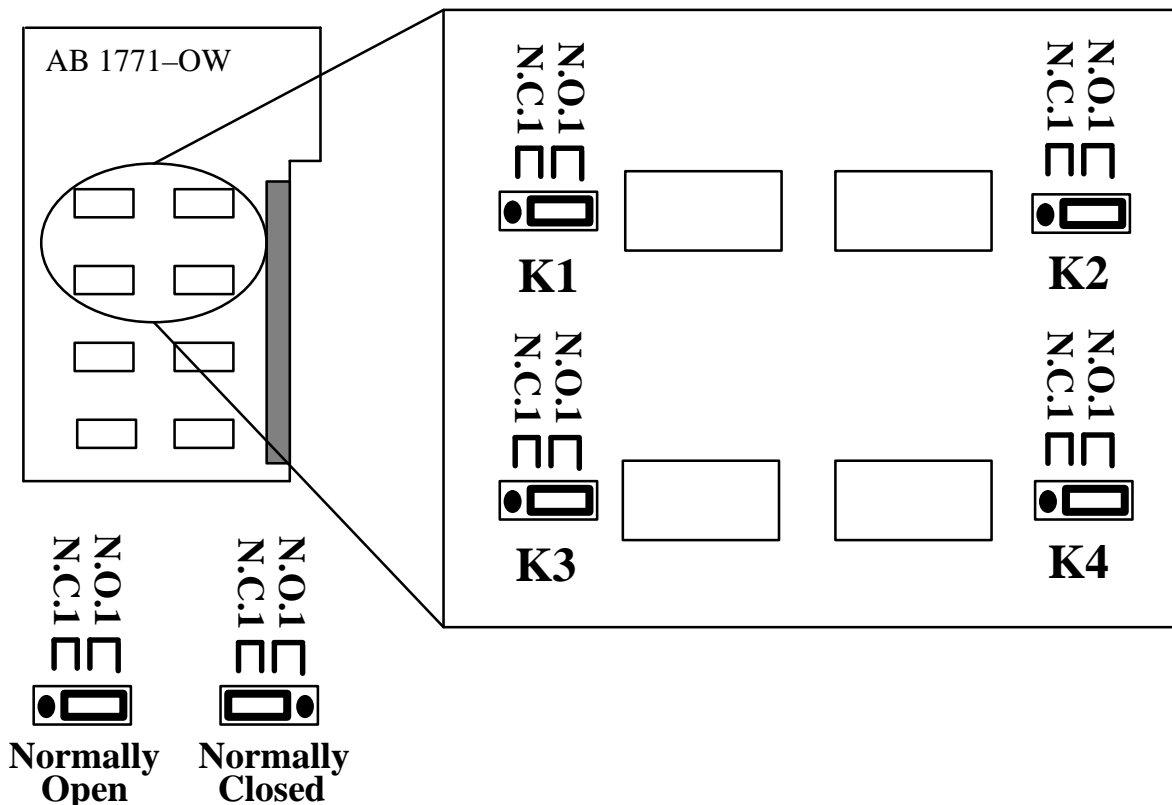

All outputs are individually selectable for either N.O. or N.C. operation. To select N.O. or N.C. settings refer to figure 10.1 for strap location and settings. K1 corresponds to signal 0 and K8 corresponds to signal 7. Note that figure 10.1 shows only the top four jumper points.

## 10.3 1771–OW Contact Output Module Installation

### 10.3.1 Power Requirements

The Allen–Bradley 1771–OW Contact Output Module may be installed in any Allen–Bradley Universal I/O Chassis, 1771–A1B, 1771–A2B, 1771–A3B, or 1771–A4B. Before installation, calculate the power requirements of the modules currently in the chassis. Add to that **700mA @ 5V DC**, the current required by the 1771–OW. Check to be sure that this combined current requirement does not exceed the current driving ability of the chassis power supply.

### 10.3.2 Module Location in the I/O Chassis

The 1771–OW may be placed in any slot of the I/O chassis with the exception of the extreme left slot. This slot is occupied by the Remote I/O Adapter Module. It is suggested that analog input modules and low voltage DC modules be placed away from AC modules or high voltage DC modules to minimize electrical noise interference.

### 10.3.3 Module Keying

The Allen Bradley Universal I/O chassis have the ability to limit the slot access to certain modules by the implementation of a keying system. Modules are slotted in two places at the edge of the circuit board. The position of the keying bands on the backplane connector of the I/O chassis must correspond to these slots. To key a slot for use by the 1771–OW Contact Output only, place the keying bands between **6** and **8** and between **16** and **18** on the I/O chassis backplane connector.

### 10.3.4 Module Insertion

Before a module is inserted into the Universal I/O Chassis, be sure that the power to the chassis is shut off. This can be done without shutting off the IOC that the Universal I/O Chassis is connected to, and without removing the subnet communication link. To insert the module, place it in the plastic tracks on the top and bottom of the Universal I/O Chassis. Slide the module into the Universal I/O Chassis until the module comes in contact with the backplane connector. Do not force the module in, instead apply firm and even pressure on the module to seat it properly on the backplane connector. Snap the chassis latch over the top of the module and connect the wiring arm to the module. The Universal I/O Chassis should begin communicating with the host IOC when power is reapplied, no rebooting of the IOC will have to be done.

## 10.4 1771–OW Contact Output Module Wiring Connection

Connecting field wiring to the 1771–OW is accomplished through the use of the wiring arm. Signals should be connected to the screw terminals on the wiring arm, as detailed in figure 10.2, and the wiring arm should be connected to the front tab connector on the 1771–OW. Note: The Contacts in figure 10.2 show the factory default configuration. Each relay can be configured for either N.O. or N.C. operation. Refer to section 10.2 to properly configure each relay individually. When shielded cable is used and grounding of the shield is desired, it is recommended that the connection be made at one of the I/O chassis mounting bolts. To prevent ground loops only one end of the cable shield should be grounded.

**Figure 10.2** Contact Output Connections

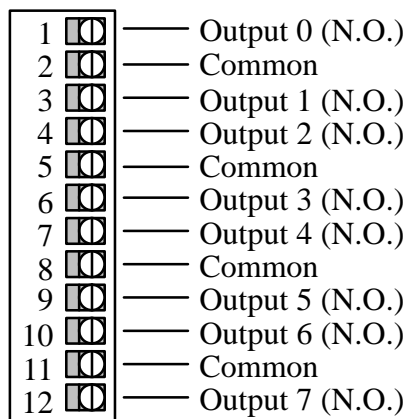

### 10.5 1771–OW Contact Output Module Use

The front panel of the 1771–OW contains eight **red** LED indicators. Each indicator is lit when its corresponding relay is energized. The Top LED will indicate the status of signal 0, while the bottom LED will indicate the status of signal 7.

## CHAPTER 11 Allen–Bradley 1771–IBD DC (10–30V) Input Module

### 11.1 1771–IBD DC (10–30V) Input Module

The 1771–IBD DC (10–30V) Input Module accepts DC voltage levels on 16 inputs and converts these signals to logic levels. The minimum input current rating is 4mA at 10V DC and 12mA at 30V DC. The minimum on state voltage is 10V DC. The Maximum off state current is 2.4mA, and the maximum off state voltage is 6V DC. The input impedance of the module is 2.5K ohms maximum per channel.

### 11.2 1771–IBD DC (10–30V) Input Module Strapping

The 1771–IBD DC (10–30V) Input Module has a fault mode which may be configured. This fault mode is independent of the last state switch on the Universal I/O Chassis backplane, and will place the inputs of the module in the corresponding state if a fault is detected. To configure the fault mode jumper, locate the jumper at the top edge of the module circuit board as it appears in figure 11.1. Configure the 2 position jumper on the middle and LS pin of the three pin header for last state fault mode. Configure the two position jumper on the middle and RESET pin of the three pin header for reset fault mode.

**Figure 11.1**

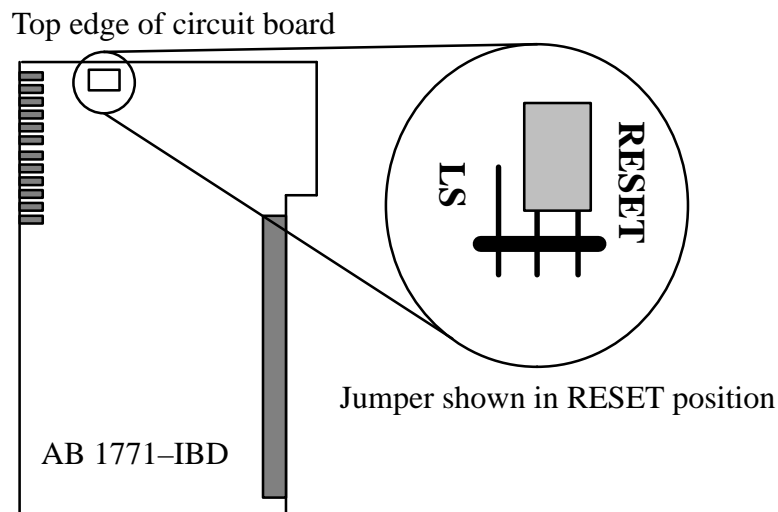

### 11.3 1771–IBD DC (10–30V) Input Module Installation

#### 11.3.1 Power Requirements

The Allen–Bradley 1771–IBD may be installed in any Allen–Bradley Universal I/O Chassis, 1771–A1B, 1771–A2B, 1771–A3B, or 1771–A4B. Before Installation, calculate the power requirements of the modules currently in the chassis. Add to that **250mA @ 5V DC**, the current required by the 1771–IBD. Check to be sure that this combined current requirement does not exceed the current driving ability of the chassis power supply.

### 11.3.2 Module Location in the I/O Chassis

The 1771–IBD may be placed in any slot of the I/O chassis with the exception of the extreme left slot. This slot is occupied by the Remote I/O Adapter Module. It is suggested that analog input modules and low voltage DC modules be placed away from AC modules or high voltage DC modules to minimize electrical noise interference.

The 1771–IBD has an additional restriction. EPICS software reads and writes the Allen–Bradly chassis in Two–slot addressing mode. A module group is considered to contain two Allen–Bradly slots. The first module group address is located at slot 0 and 1. The second is slot 2 and 3 and so on. When using a 16–bit **input** module in a two–slot addressing mode, the **input** module must always be inserted into an **even** number slot (left–hand side of the module group). A complementary **output** module (8–bit or 16–bit module) may be inserted into an **odd** number slot (right–hand side of the module group) completing the module group. If no complementary module is used then that slot must remain empty.

### 11.3.3 Module Keying

The Allen Bradley Universal I/O chassis have the ability to limit the slot access to certain modules by the implementation of a keying system. Modules are slotted in two places at the edge of the circuit board. The position of the keying bands on the backplane connector of the I/O chassis must correspond to these slots. To key a slot for use by the 1771–IQ Contact Output only, place the keying bands between **10** and **12** and between **16** and **18** on the I/O chassis backplane connector.

### 11.3.4 Module Insertion

Before a module is inserted into the Universal I/O Chassis, be sure that the power to the chassis is shut off. This can be done without shutting off the IOC that the Universal I/O Chassis is connected to, and without removing the subnet communication link. To insert the module, place it in the plastic tracks on the top and bottom of the Universal I/O Chassis. Slide the module into the Universal I/O Chassis until the module comes in contact with the backplane connector. Do not force the module in, instead apply firm and even pressure on the module to seat it properly on the backplane connector. Snap the chassis latch over the top of the module and connect the wiring arm to the module. The Universal I/O Chassis should begin communicating with the host IOC when power is reapplied, no rebooting of the IOC will have to be done.

## 11.4 1771–IBD DC (10–30V) Input Module Wiring Connection

Connecting field wiring to the 1771–IBD is accomplished through the use of the wiring arm. Signals should be connected to the screw terminals of the wiring arm, as detailed in figure 11.2, and the wiring arm should be connected to the front tab connector on the 1771–IBD. Note that on the wiring arm the inputs are labeled 00 – 17 (octal). When shielded cable is used and grounding of the shield is desired, it is recommended that the connection be made at one of the I/O chassis mounting bolts. To prevent ground loops only one end of the cable shield should be grounded.



Figure 11.2

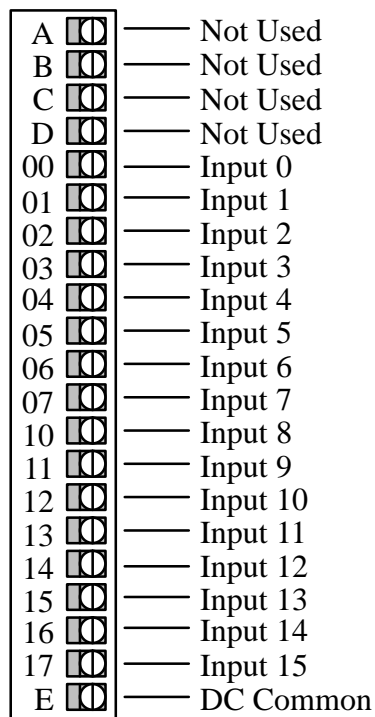

### 11.5 1771–IBD DC (10–30V) Input Module Use

The front panel on the 1771–IBD contains 17 LED indicators. The top **green** LED indicator labeled ACTIVE indicates the module is connected to +5 volts and operating normally. The next 16 **red** LED indicators, labeled 00 through 17 (octal), will indicate if an input is true. The indicator will be illuminated if the input is true (there is voltage at the terminal) and out if the input is false (there is no voltage at the terminal).

## CHAPTER 12 Allen–Bradley 1771–OBD DC (10–60V) Output Module

### 12.1 1771–OBD DC (10–60V) Output Module

The 1771–IBD DC (10–60V) Output Module produces a DC voltage level on any combination of 16 outputs. The voltage level output is determined by a user supplied power supply. The maximum output current is 2A per output, not to exceed 8A per module.

### 12.2 1771–OBD DC (10–60V) Output Module Strapping

The 1771–OBD DC (10–60V) Output Module has a fault mode which may be configured. This fault mode is independent of the last state switch on the Universal I/O Chassis backplane, and will place the outputs of the module in the corresponding state if a fault is detected. To configure the fault mode jumper, locate the jumper at the bottom edge of the module circuit board as it appears in figure 12.1. Configure the 2 position jumper on the middle and LS pin of the three pin header for last state fault mode. Configure the two position jumper on the middle and RESET pin of the three pin header for reset fault mode.

Figure 12.1

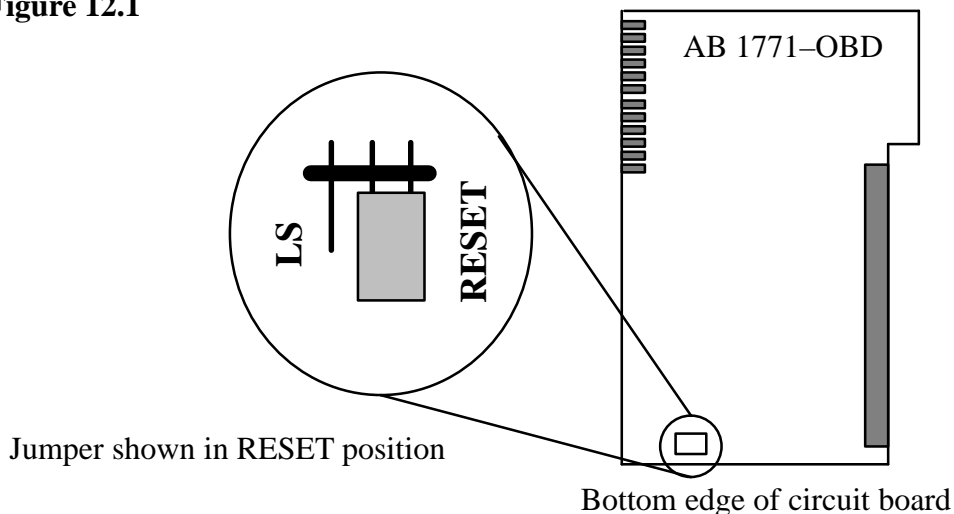

### 12.3 1771–OBD DC (10–60V) Output Module Installation

#### 12.3.1 Power Requirements

The Allen–Bradley 1771–OBD may be installed in any Allen–Bradley Universal I/O Chassis, 1771–A1B, 1771–A2B, 1771–A3B, or 1771–A4B. Before installation, calculate the power requirements of the modules currently in the chassis. Add to that **400mA @ 5V DC**, the current required by the 1771–IBD. Check to be sure that this combined current requirement does not exceed the current driving ability of the chassis power supply.

### 12.3.2 Module Location in the I/O Chassis

The 1771–OBD may be placed in any slot of the I/O chassis with the exception of the extreme left slot. This slot is occupied by the Remote I/O Adapter module. It is suggested that analog input modules and low voltage DC modules be placed away from AC modules or high voltage DC modules to minimize electrical noise interference.

The 1771–OBD has an additional restriction. EPICS software reads and writes the Allen–Bradly chassis in Two–slot addressing mode. A module group is considered to contain two Allen–Bradly slots. The first module group address is located at slot 0 and 1. The second is slot 2 and 3 and so on. When using a 16–bit **output** module in a two–slot addressing mode, the output module must always be inserted into an **odd** number slot (right–hand side of the module group). A complementary **input** module (8–bit or 16–bit module) may be inserted into an **even** number (left–hand side of the module group) slot completing the module group. If no complementary module is used then that slot must remain empty.

### 12.3.3 Module Keying

The Allen Bradley Universal I/O chassis have the ability to limit the slot access to certain modules by the implementation of a keying system. Modules are slotted in two places at the edge of the circuit board. The position of the keying bands on the backplane connector of the I/O chassis must correspond to these slots. To key a slot for use by the 1771–IQ Contact Output only, place the keying bands between **10** and **12** and between **22** and **24** on the I/O chassis backplane connector.

### 12.3.4 Module Insertion

Before a module is inserted into the Universal I/O Chassis, be sure that the power to the chassis is shut off. This can be done without shutting off the IOC that the Universal I/O Chassis is connected to, and without removing the subnet communication link. To insert the module, place it in the plastic tracks on the top and bottom of the Universal I/O Chassis. Slide the module into the Universal I/O Chassis until the module comes in contact with the backplane connector. Do not force the module in, instead apply firm and even pressure on the module to seat it properly on the backplane connector. Snap the chassis latch over the top of the module and connect the wiring arm to the module. The Universal I/O Chassis should begin communicating with the host IOC when power is reapplied, no rebooting of the IOC will have to be done.

## 12.4 1771–OBD DC (10–60V) Output Module Wiring Connection

Connecting field wiring to the 1771–OBD is accomplished through the use of the wiring arm. Signals should be connected to the screw terminals of the wiring arm, as detailed in figure 12.2, and the wiring arm should be connected to the front tab connector on the 1771–OBD. Note that on the wiring arm the outputs are labeled 00 – 17 (octal). When shielded cable is used and grounding of the shield is desired, it is recommended that the connection be made at one of the I/O chassis mounting bolts. To prevent ground loops only one end of the cable shield should be grounded.

Figure 12.2

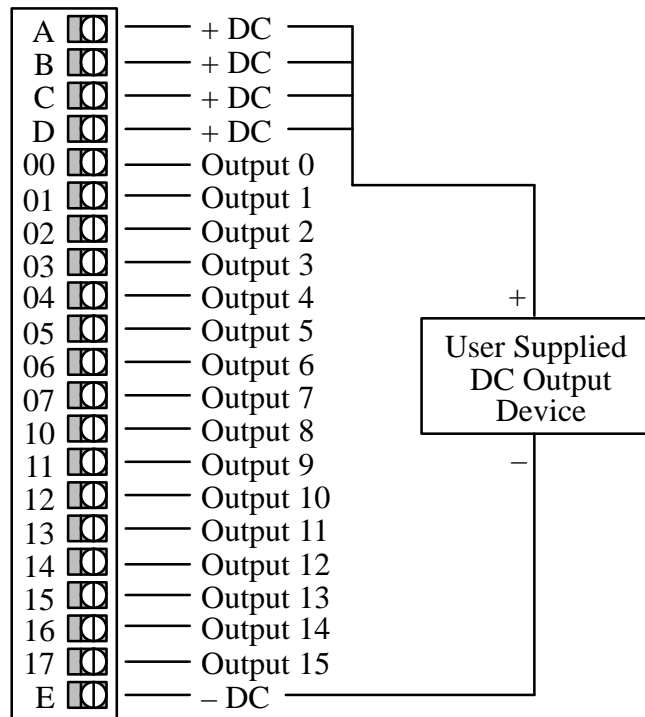

### 12.5 1771–OBD DC (10–60V) Output Module Use

The front panel on the 1771–OBD contains 18 LED indicators. The top **green** LED indicator labeled ACTIVE indicates the module is connected to +5 volts and operating normally. The next 16 **red** LED indicators, labeled 00 through 17 (octal), will indicate if an output is true. The indicator will be illuminated if the output is true (there is voltage at the terminal) and out if the output is false (there is no voltage at the terminal). There is also a **red** LED FUSE indicator. This will be illuminated if the on–board output protection fuse is blown.

## CHAPTER 13 Allen–Bradley 1771–IXE Thermocouple / Millivolt Input Module

### 13.1 1771–IXE Thermocouple / Millivolt Input Module

The 1771–IXE senses up to 8 differential analog inputs and converts them to a proportional 12 bit binary value. The 1771–IXE will support E, J, K, T, R, and S thermocouples, as well as a range of +/- 100mV. These ranges are selectable in the EPICS database configuration software.

### 13.2 1771–IXE Thermocouple / Millivolt Input Module Strapping

No strapping of the 1771–IXE Module is required.

### 13.3 1771–IXE Thermocouple / Millivolt Input Module Installation

#### 13.3.1 Power Requirements

The Allen–Bradley 1771–IXE Analog Input Module may be installed in any Allen–Bradley Universal I/O Chassis, 1771–A1B, 1771–A2B, 1771–A3B, or 1771–A4B. Before Installation, calculate the power requirements of the modules currently in the chassis. Add to that **1.2A @ 5V DC**, the current required by the 1771–IFE. Check to be sure that this combined current requirement does not exceed the current driving ability of the chassis power supply.

#### 13.3.2 Module Location in the I/O Chassis

The 1771–IFE may be placed in any slot of the I/O chassis with the exception of the extreme left slot. This slot is occupied by the Remote I/O Adapter Module. It is suggested that analog input modules and low voltage DC modules be placed away from AC modules or high voltage DC modules to minimize electrical noise interference.

#### 13.3.3 Module Keying

The Allen Bradley Universal I/O chassis have the ability to limit the slot access to certain modules by the implementation of a keying system. Modules are slotted in two places at the edge of the circuit board. The position of the keying bands on the backplane connector of the I/O chassis must correspond to these slots. To key a slot for use by the 1771–IFE Analog Input only, place the keying bands between **20** and **22** and between **24** and **26** on the I/O chassis backplane connector.

#### 13.3.4 Module Insertion

Before a module is inserted into the Universal I/O Chassis, be sure that the power to the chassis is shut off. This can be done without shutting off the IOC that the Universal I/O Chassis is connected to, and without removing the subnet communication link. To insert the module, place it in the plastic tracks on the top and bottom of the Universal I/O Chassis. Slide the module into the Universal I/O Chassis until the module comes in contact with the backplane connector. Do not force the module in, instead apply firm and even pressure on the module

to seat it properly on the backplane connector. Snap the chassis latch over the top of the module and connect the wiring arm to the module. The Universal I/O Chassis should begin communicating with the host IOC when power is reapplied, no rebooting of the IOC will have to be done.

### 13.4 1771–IXE Thermocouple / Millivolt Input Module Wiring Connection

Connection of analog signals to the 1771–IXE is accomplished through the use of the wiring arm. Signals should be connected to the screw terminals on the wiring arm, as detailed in figure 13.1, and the wiring arm should be connected to the front tab connector on the 1771–IXE. The recommend maximum cable length for thermocouple signals is 1000ft for thermocouple extension wire of 18 or 22 gauge. This is based on the fact that the 1771–IXE module compensates for lead resistance up to 2000 ohms. If this lead resistance must be exceeded, refer to the thermocouple manufacturer’s specifications and instructions for compensation. When shielded cable is used and grounding of the shield is desired, it is recommended that the connection be made at one of the I/O chassis mounting bolts. To prevent ground loops only one end of the cable shield should be grounded. Note also that all unused inputs should be short circuited.

**Figure 13.1**

- 18 – Input 1 (+ Lead)
- 17 – Input 1 (– Lead)
- 16 – Input 2 (+ Lead)
- 15 – Input 2 (– Lead)
- 14 – Input 3 (+ Lead)
- 13 – Input 3 (– Lead)
- 12 – Input 4 (+ Lead)
- 11 – Input 4 (– Lead)
- 10 – Not Used
- 9 – Not Used
- 8 – Input 5 (+ Lead)
- 7 – Input 5 (– Lead)
- 6 – Input 6 (+ Lead)
- 5 – Input 6 (– Lead)
- 4 – Input 7 (+ Lead)
- 3 – Input 7 (– Lead)
- 2 – Input 8 (+ Lead)
- 1 – Input 8 (– Lead)

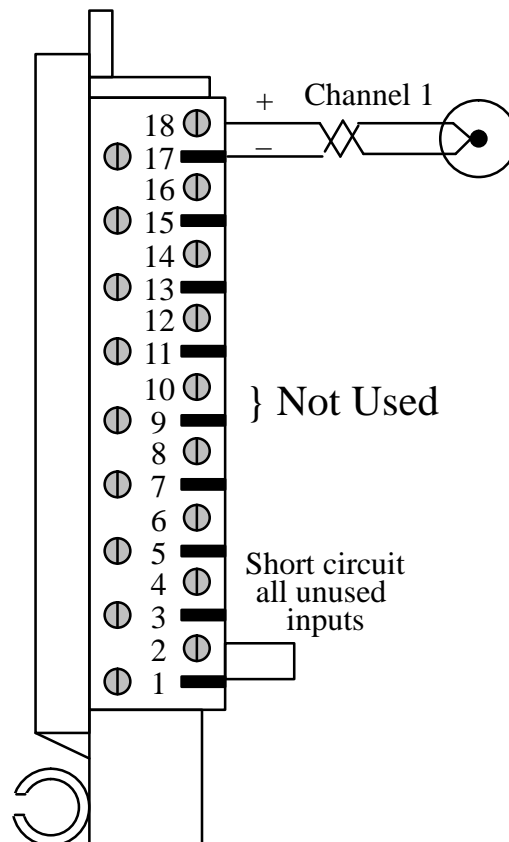

### 13.5 1771–IXE Thermocouple / Millivolt Input Module Use

The front panel of the 1771–IFE contains a **green** RUN and a **red** FAULT LED indicator. At power up an initial module self–check occurs. If there is no fault the **red** indicator will turn off. The **green** indicator will flash until the processor communicates successfully with the module.

## CHAPTER 14 Allen–Bradley 2705 RediPANEL Push Button Module

### 14.1 RediPANEL Push Button Module

The Allen–Bradley 2705 RediPANEL Push Button Module combines the functions of standard push buttons and indicator lamps, an Allen Bradley Chassis with binary input, and binary output modules, and a 1771–ASB Remote I/O Adapter Module. The RediPANEL provides 16 discrete binary inputs in the form of push buttons, and 16 discrete binary outputs in the form of indicator lamps behind the buttons. Like the 1771–ASB Remote I/O Adapter Module, the RediPANEL acts as a slave in an Allen Bradley subnet in an EPICS control system. The RediPANELs are linked via subnet connection to other RediPANELs and Remote I/O Adapters, and back to a VMEbus I/O scanner. They correspond to the **ADAPTER number** when configuring an Allen–Bradley subnet. An Allen–Bradley / EPICS subnet allows for up to 8 adapters to be located on one Allen–Bradley subnet link.

### 14.2 RediPANEL Push Button Module Configuration

Refer to figure 14.1 for the following instructions.

**Figure 14.1**

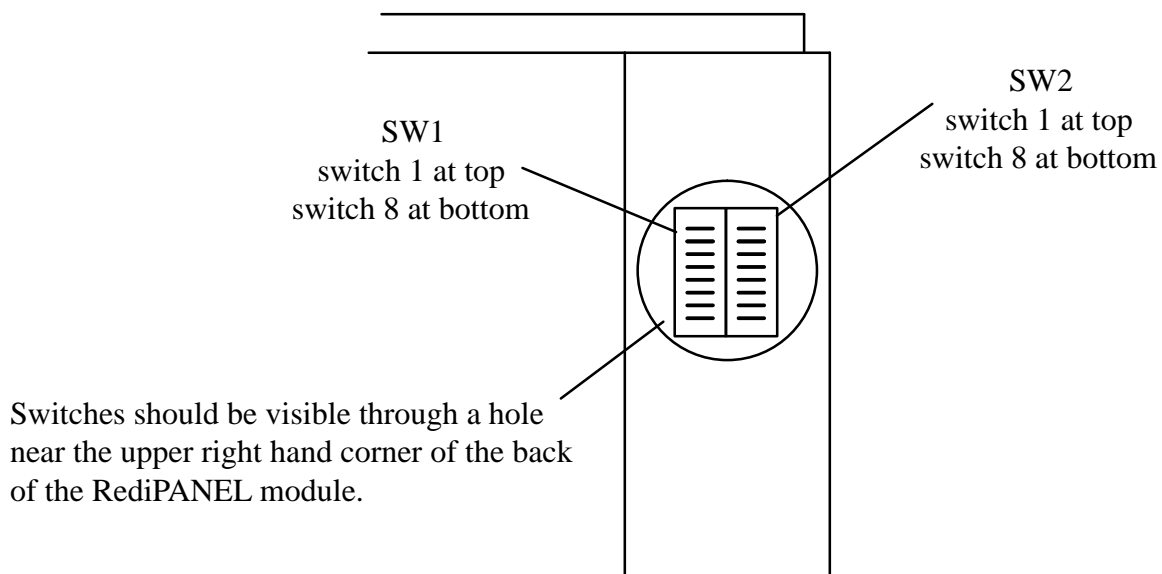

#### 14.2.1 Setting the Module Switches

SW1 is the Address Switch Assembly for the RediPANEL modules. Switches 1 – 6 select the Universal I/O Chassis adapter number. Observe figure 14.2 for the proper address settings, when the switches are closed (ON) this corresponds to a binary 0 in the adapter address, and when the switches are open (OFF) this corresponds to a binary 1 in the adapter address. Note that switches 1 – 3 must always remain in their closed (ON) positions as the EPICS control system only uses adapter addresses 0 – 7.



**Figure 14.2**

I/O Adapter Number	Switch Number		
	4	5	6
1	On	On	On
2	On	On	Off
3	On	Off	On
4	On	Off	Off
5	Off	On	On
6	Off	On	Off
7	Off	Off	On

Switches 7 and 8 should remain in the closed (ON) position as this will place the Remote I/O adapter in the 1st I/O group number 0, used in the EPICS control system.

SW2 sets the baud rate and other configurations. Switch number 1 should be closed (ON), this sets the baud rate at 57.6K baud and allows for a link distance of 10,000ft over shielded, twisted pair cable. Switches 2 and 3 respectively control the the ability to make the lamp indicators appear steady or flashing, see section 14.5.1 for more information on this. Switch number 2 should be open (OFF) to disable the steady lamp setting, and closed (ON) to enable the steady lamp setting. Switch number 3 should be open (OFF) to disable the flashing lamp setting, and closed (ON) to enable the flashing lamp setting. Switch number 4 is for the push buttons, it should be set open (OFF) to disable the push buttons, and closed (ON) to enable the push buttons. Switch number 5 controls the switch fault action. If the switch is set closed (ON), all push button operations will cease when a fault is detected using the Push–To–Test button, communication will halt, and the FAULT LED will illuminate. If the switch is set open (OFF), faulted contacts will be forced to the released state, all other switches will operate normally.

Switch number 6 should be open (OFF) as it is not used. Switch 7 should be open (OFF) to disable the handshake bit. Switch 8 controls the last state function. This switch should be closed (ON) to enable the last state function. In this mode, when communication is lost and the COMM LED is off, any output signals that were on will remain in the same state once communication is restored. If switch 8 is set open (OFF), the module will turn off any output signals that were on when communication was lost. A summary of switch positions is available in figure 14.3.

## 14.3 RediPANEL Push Button Module Installation

### 14.3.1 Power Requirements

The RediPANEL is wired via a three pin terminal block to a standard three wire AC power cord. The three pin terminal block plugs into the back of the rediPANEL and accepts 90 – 264 V AC ranging from 47 – 63 Hz. When all of the lamps are activated the internal DC power supply provides a maximum of 360 mA of current. If all of the lamps are de–activated, the current draw on the internal DC supply is 190mA.

**Figure 14.3**

S1 Switch Number								S2 Switch Number							
1	2	3	4	5	6	7	8	1	2	3	4	5	6	7	8
On	On	On	Figure 14.2	On	On	On	On	On	X	X	X	X	Off	Off	X

On = Closed

Off = Open

X = Refer to written instructions above

**14.3.2 Mechanical**

In order to protect the RediPANEL against heat, soot, moisture and other forms of contamination, an enclosure is required. When choosing an enclosure for the RediPANEL, it is advised to follow the standards developed by the National Electrical Manufacturers Association (NEMA). Refer to NEMA Standard # 250, "Enclosures for Electrical Equipment" to find a suitable enclosure.

Each RediPANEL comes with two mounting brackets and a cut–out template to simplify installation. The panels can be mounted either horizontally or vertically. Mounting multiple panels horizontally requires at least one inch of spacing around the mounting flange, vertical spacing should be at least 6 inches between cut–outs. In both cases, the depth of the enclosure should be at least 8 inches.

**14.4 RediPANEL Push Button Module Wiring Connection**

Figure 14.4 details the wiring connections to the RediPANEL mating connector. After the wires are inserted into the connector as detailed in figure 14.4, the connector can be plugged into the receptacle located near the lower right hand corner of the back of the RediPANEL. The AC power must also be connected as mentioned in 14.3.1.

**Figure 14.4**

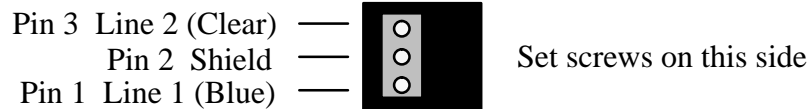

**14.5 RediPANEL Push Button Module Module Use**

**14.5.1 Mapping to EPICS**

Mapping the the buttons to an EPICS control system is quite simple. There are 16 buttons, and 16 lamp indicators, divided into 4 "cards". The first 8 buttons are represented as CARD 0, binary inputs SIGNALS 0–7, and the second 8 buttons are represented as CARD 1, binary inputs SIGNALS 0–7. Likewise, for steady lamp operation, the first 8 lamp indicators are

represented as CARD 0, binary outputs SIGNALS 0 – 7, and the second 8 lamp indicators are represented as CARD 1, binary outputs SIGNALS 0 – 7. For flashing lamp operation, the first 8 buttons are still represented as CARD 0, binary inputs SIGNALS 0 – 7, and the second 8 buttons are represented as CARD 1, binary inputs SIGNALS 0 – 7. However, the first 8 lamp indicators are represented as CARD 2, binary outputs SIGNALS 0 – 7, and the second 8 lamp indicators are represented as CARD 3, binary outputs SIGNALS 0 – 7. A map of the RediPANEL buttons, and indicators is shown in figure 14.5. Keep in mind that the for steady lamp operation, both the button and the lamp indicator associated with a location on the RediPANEL share the same CARD and SIGNAL address, however, the button is discerned as a binary input, and the lamp indicator is discerned as a binary output.

**Figure 14.5**

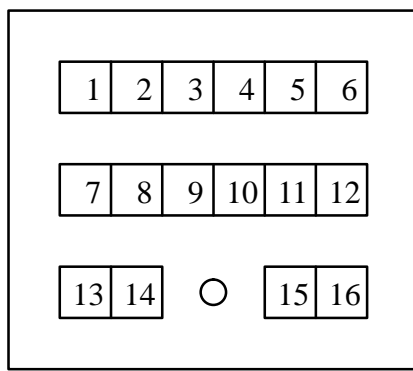

Buttons:

Location 1 – 8 = CARD 0, SIGNALS 0 – 7

Location 9 – 16 = CARD 1, SIGNALS 0 – 7

Indicator Lamps:

Steady Lamps:

Location 1 – 8 = CARD 0, SIGNALS 0 – 7

Location 9 – 16 = CARD 1, SIGNALS 0 – 7

Flashing Lamps:

Location 1 – 8 = CARD 2, SIGNALS 0 – 7

Location 9 – 16 = CARD 3, SIGNALS 0 – 7

It may also be helpful to note that the EPICS binary input records for the push buttons may be set to I/O Interrupt Scan. The record will be scanned on a change of state of the push buttons as opposed to a "time" scan where one is forced to scan at a fast rate in order to "catch" the pressing of a button.

### 14.5.2 Diagnostic Indicators

In the upper right hand corner of the RediPANEL there is a **green** COMM LED indicator, and a **red** FAULT LED indicator. The possible combinations of indicator actions are listed in figure 14.6.

### 14.5.3 LED and Lamp Test

To test the indicator lamps and the LED indicators press the white round button labeled TEST on the bottom of the panel. When a test cycle is executed, all of the indicator lamps and LEDs will first go on for one second, then go off for two seconds, then return to the state they were in before the TEST button was pressed.

**Figure 14.6**

Lamp	Action	Possible Cause
COMM	Off	RediPANEL not communicating, check power and link
COMM	On	RediPANEL communicating properly, no faults detected
COMM	Blinking	Communication with the RediPANEL not yet established
FAULT	Off	RediPANEL operating properly, no faults detected
FAULT	On	Fault detected, power cycle the RediPANEL
FAULT	Blinking	DIP switch fault, re-configure DIP switches properly