

# LABORATORIES FOR THE 21ST CENTURY: BEST PRACTICES



John Hopkins School of Medicine/PIX12799

The Bunting Blaustein Cancer Research Building in Baltimore, Maryland, is one of several buildings at Johns Hopkins that use enthalpy wheels for energy recovery.

## ENERGY RECOVERY FOR VENTILATION AIR IN LABORATORIES

### Introduction

Energy recovery can substantially reduce the mechanical heating and cooling requirements associated with conditioning ventilation air in most laboratories. Laboratories typically require 100% outside air at high ventilation rates—between 6 and 15 air changes per hour—primarily for safety reasons. The heating and cooling energy needed to condition this air, as well as the fan energy needed to move it, is 5 to 10 times greater than the amount of energy used in most offices for those purposes. Heating and cooling systems can be downsized when energy recovery is used, because energy recovery systems reduce peak heating and cooling requirements.

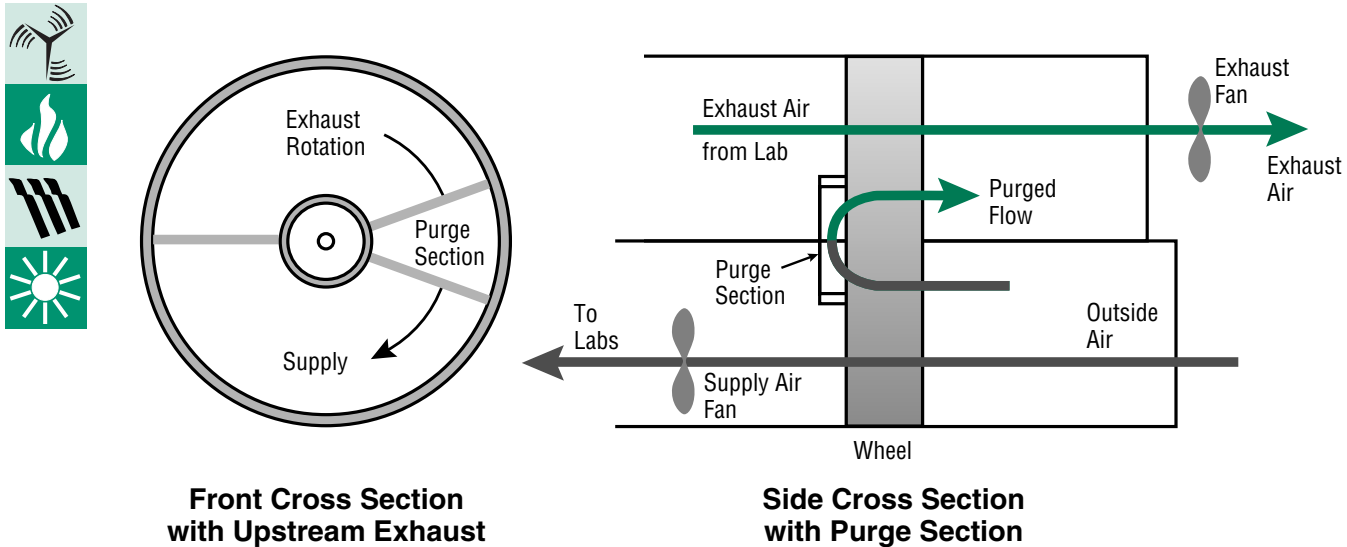

034349006m

Figure 1. Cross sections (front and side) of enthalpy wheel system with purge section

There are many opportunities for energy recovery in laboratories, and a few of them are covered here. Energy recovery can occur between any two media or processes that differ in energy content. The main focus of this guide is on air-to-air energy recovery—using enthalpy wheels (Figure 1), heat pipes, or run-around loops in new construction. Most commonly, energy is recovered from exhaust air and used to precondition supply air. Before deciding on an energy-recovery technology, laboratory managers are encouraged to perform a life-cycle cost analysis to determine the feasibility of the application in their laboratories. As a rule, the shortest payback periods occur when the heating and cooling load reduction provided by an energy recovery system allows the laboratory to use smaller hot water and chilled water systems.

This guide to energy recovery is one in a series on best practices for laboratories. It was produced by *Laboratories for the 21st Century* (“Labs 21”), a joint program of the U.S. Environmental Protection Agency and the U.S. Department of Energy. Geared toward architects, engineers, and facility managers, these guides provide information about technologies and practices to use in designing, constructing, and operating safe, sustainable, high-performance laboratories.

## Technology Description

Air-to-air energy recovery devices exchange energy from one stream of air to another. The air contains sensible (heat) and latent (water vapor) energy. Both types of energy can be recovered; however, not all recovery devices exchange both types of energy. The effectiveness of an energy recovery device reflects the efficiency of the device in recovering available energy. Most devices have a rating

for sensible effectiveness; some also have a rating for latent effectiveness and total effectiveness.

Energy recovery devices increase the pressure drop across the supply and exhaust fans. Enthalpy wheels generally have a lower pressure drop than heat pipes and run-around loops, although the pressure drop depends on the design. An additional pressure drop of no more than 1 inch water gauge (1 in. w.g.) in the supply and exhaust air streams is a reasonable design goal, and it will minimize the increase in fan energy. For example, an increase in pressure drop of 1 in. w.g. on a 76% efficient fan and a 95% efficient motor assembly results in an increase in fan energy of 0.16 watt per cubic foot of air per minute (W/cfm). The total increase for supply and exhaust fans together is 0.32 W/cfm.

For laboratory applications, the design face velocity is typically 500 fpm or less. Lower face velocities result in lower pressure drops, higher effectiveness, and lower operating costs. The trade-off is larger air handling equipment and higher first costs. An energy recovery device will operate more efficiently with a variable-air-volume (VAV) system than with a constant-volume system, because VAV systems typically operate at face velocities lower than those of design conditions.

**Enthalpy wheels.** Enthalpy wheels, or rotary heat exchangers, transfer sensible or latent energy (or both) between the exhaust air and the incoming outside air (Figure 1). The supply and exhaust streams must be located next to each other. Both sensible-only wheels and total energy wheels, sometimes referred to as desiccant wheels, are available. A 50,000 cfm total energy wheel can have a sensible and latent effectiveness as high as 75%, which results in a total effectiveness of 75%. Control of the wheel

at part loads is accomplished by varying the speed of the wheel, or using a bypass duct, or both.

The type of desiccant used in a total energy wheel must be designed to transfer only moisture and not air-borne contaminants. To further reduce potential contamination of the supply air stream, the wheel is flushed with supply air that is deflected by a damper in the purging section of the rotor. The damper redirects supply air leaving the wheel to the inlet side of the wheel exhaust. The purge section utilizes the pressure difference between the supply air and exhaust air streams (see Figure 1). Purge volumes for laboratory applications are typically between 5% and 10%, so additional fan energy is required to move this air.

The Whitehead Biomedical Research Building at Emory University in Atlanta, Georgia, uses enthalpy wheels for energy recovery between the supply and exhaust air streams. The installation cost for the wheels was reported at \$425,000, and anticipated energy savings are \$125,000 per year. The simple payback is less than four years.

**Heat pipes.** Heat pipes transfer only sensible energy. If air is cooled to below its dew point, however, condensation occurs on the heat pipe and results in some latent heat transfer. In heat pipe applications, the supply and exhaust air streams are next to one another, although some modified or “split” heat pipes allow the air streams to be separated.

The sensible effectiveness of heat pipes is between 45% and 65%. Cross-contamination is not an issue. Heat pipes have no moving parts, and failure of the entire unit

is rare. A tube may malfunction, but other tubes continue to transfer energy. Heat pipes can be controlled for part-load operation with a bypass duct or by tilting the unit.

Heat pipes can be used as indirect evaporative coolers, in which water is sprayed on the exhaust side of the pipe to precool the supply air (Figure 2). This application has been successful at the Fox Chase Cancer Center in Philadelphia, Pennsylvania, and in the Process and Environmental Technology Laboratory at Sandia National Laboratories in Albuquerque, New Mexico.

**Run-around loops.** Run-around loops circulate a fluid between two air streams. This technology may seem familiar to most designers because it usually just involves additional coils and pumps. The air streams do not need to be next to one another, and there are no cross-contamination issues. Run-around loops have a sensible effectiveness between 55% and 65%. In the U.S. Department of Agriculture’s new laboratory in Ames, Iowa, the preheat coil and run-around loop coil are combined, so the added pressure drop in the supply system is lower than that of a system with separate energy recovery and preheat coils.

Run-around loops are well-suited for transferring energy between process loads and ventilation air. Fred Hutchinson Cancer Research Center in Seattle, Washington, uses a run-around loop to take heat rejected from the process cooling water system to preheat outside air, thus providing free cooling of the process cooling water.

Run-around loops and heat pipes can also be used to reduce reheat energy by transferring heat from the outdoor air to a reheat device located next to the

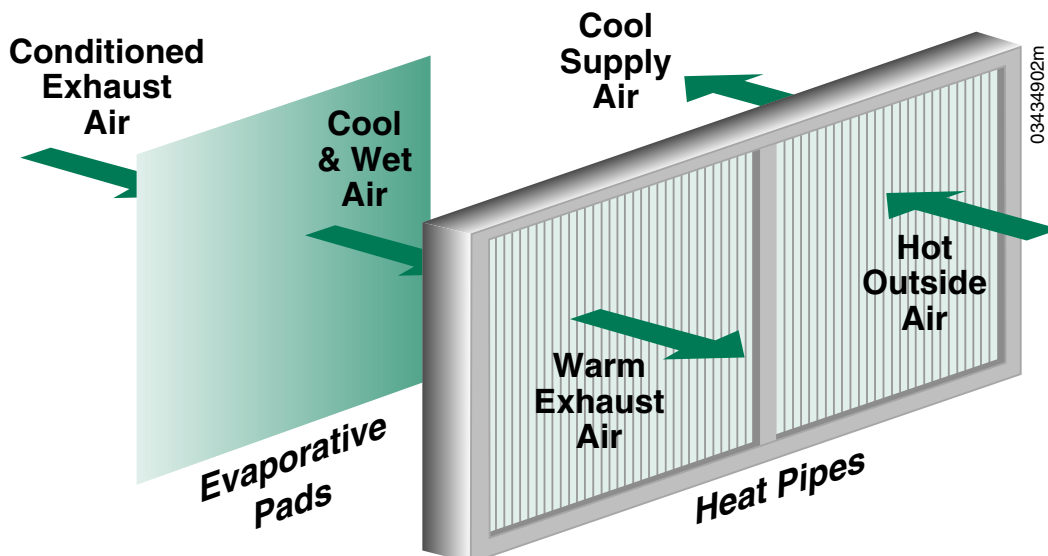

Figure 2. Heat pipe system



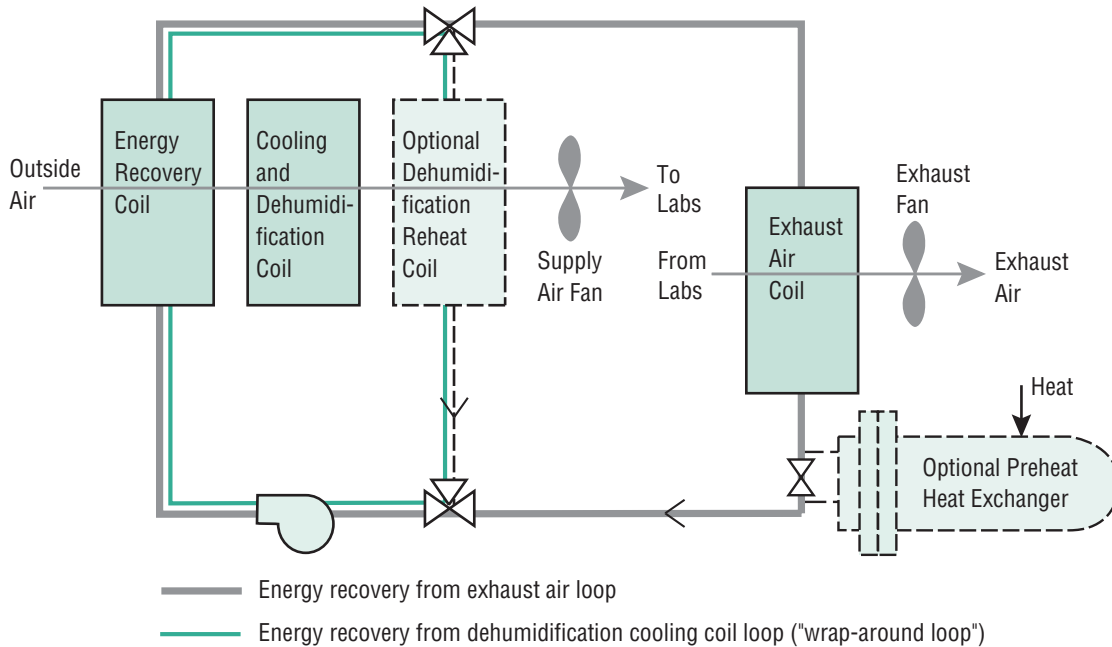

Figure 3. Run-around energy recovery loop with dehumidification

dehumidification cooling coil in warm, humid climates. The energy recovery device precools the outside air before the air enters the main dehumidification cooling coil, and the dehumidification reheat device reheats the air leaving the main cooling coil. This precooling and reheating can be accomplished with a device that wraps around the cooling coil, often called a “wrap-around loop.” It can also be accomplished with two energy recovery stages between the supply and exhaust air streams on either side of the cooling coil. A wrap-around loop can be added to a run-around energy recovery loop by adding a coil on the leaving side of the cooling coil (Figure 3). The Viral Immunology Center at Georgia State in Atlanta, Georgia, uses a packaged rooftop ventilation dehumidification unit with two heat pipes. In the summer, one heat pipe precools the outside air by transferring heat to the exhaust air, the mechanical system DX coil subcools the air, and the other heat pipe reheats the air with heat recovered from the exhaust air. In the winter, both heat pipes are used to heat the air.

## Design Considerations

The following are some considerations that can help you determine whether air-to-air energy recovery is feasible for your project.

### Schematic Design

- Identify energy recovery opportunities. Manifold exhaust systems are ideally suited to energy recovery because all the potentially available energy can be captured by one energy recovery system.

- Consider the location of the supply and exhaust. If they can be located next to one other, enthalpy wheels and heat pipes can be used. Otherwise, modified heat pipes and run-around loops are best suited for separate supply and exhaust.
- Consider a wrap-around loop, if enthalpy wheels are not an option in warm, humid climates where dehumidification is necessary.
- Assess the risk associated with cross-contamination of the air streams. Purge sections on enthalpy wheels reduce cross-contamination to below 0.1%, according to ASHRAE. There are no cross-contamination issues with heat pipes and run-around loops.
- Address the potential for fouling and corrosion of the devices. Routine maintenance and controls may be sufficient, although the most suitable equipment depends on the chemicals being released into the air stream. Select air filters with a low pressure drop.
- Determine the space requirement for additional equipment needed and its impact on design and costs.
- Estimate operation and maintenance costs for the device, as well as replacement costs.
- Calculate the impact of energy recovery on energy costs.
- Include the cost benefit of being able to downsize the heating and cooling systems.

### ***Design Development and Construction Documents***

- Identify appropriate control strategies for part-load operation and for preventing condensation and potential freezing. Using bypass ducts reduces the increase in fan energy.
- Clearly define the commissioning of the energy recovery device.

### **Codes and Standards**

As with all building components, various codes and standards apply to energy recovery. There are standards for testing the performance of the equipment and standards that specify when energy recovery must or must not be applied. American Industrial Hygiene Association codes and standards affecting laboratories can be found on the Web (see [www2.umdnj.edu/eohssweb/aiha/technical/codes.htm#Energy](http://www2.umdnj.edu/eohssweb/aiha/technical/codes.htm#Energy), accessed in 2003). Here is a brief overview of codes and standards pertaining to energy recovery:

- Air-Conditioning and Refrigeration Institute (ARI) Standard 1060-2000 for Air-to-Air Energy Recovery Ventilation Equipment rates the sensible, latent, and total effectiveness of equipment, excluding run-around loops. The ratings are performed by an independent laboratory per ASHRAE 84 (see below), except as amended by ARI 1060. The ARI-certified product directory (2001) is a useful resource for identifying various manufacturers and their products and for comparing effectiveness ratings.
- American National Standards Institute (ANSI)/ASHRAE Standard 84-1991, Method of Testing Air-to-Air Heat Exchangers, specifies the data, equipment, and reporting procedures for testing the sensible, latent, and total effectiveness of air-to-air heat exchangers. There are similar Canadian and European standards.
- In the most recently adopted version of the International Mechanical Code (2003), section 514 has been added to cover the installation of energy recovery ventilation. This section prohibits the use of all types of energy recovery ventilation, including heat pipes and run-around loops, with hazardous exhaust systems, as defined in section 510. This is a significant change to the 2000 version of the code.
- National Fire Protection Association (NFPA) 45 (2001) states that, if there is a chance of cross-contamination between air streams, air-to-air energy recovery can be used only on general exhaust. The code has not been

### **Key Issues Concerning Energy Recovery in Laboratories**

Integration of energy recovery into a laboratory ventilation system requires careful consideration of some key issues. Design teams have taken different approaches to handling these issues, which demonstrates the importance of considering all options.

**Contamination.** If cross-contamination from fume hood exhaust is an issue, consider heat pipes or run-around loops. Another approach is isolating the fume hood exhaust and recovering energy from the general exhaust only. Note that the chemicals in the fume hood exhaust may become too concentrated and require additional treatment.

**Space requirements and duct adjacencies.** Enthalpy wheels and most types of heat pipes require the main supply and exhaust ducts to be located next to each other; run-around loops do not. Additional space is required for the energy recovery device, typically in the makeup air unit and main exhaust duct. Run-around loops also require space for a pump.

**Hazardous chemicals.** If isolating the fume hood exhaust or condensate from a heat recovery device results in too high a concentration of volatile organic compounds, disposal could become a problem. Potential hazardous waste issues need to be addressed early on.

**Humidity.** If humidity is being controlled, energy used for space heating will increase by an estimated 25%. The potential energy savings with energy recovery increases and so do the possible alternatives. Desiccant wheels can be used for dehumidification, wrap-around coils can be used for reducing reheat energy, and evaporative cooling can be used for humidification. Avoid over-specifying control of humidity; the wider the control range, the less energy used.

**Maintenance.** Maintenance differs according to the type of energy recovery and the application. Heat pipes appear to have the lowest maintenance requirements, followed by run-around loops. Periodic cleaning needs depend on the fouling and corrosion potential of the exhaust air, but cleaning is critically important to maintaining the performance of the equipment.

**Part-load operation.** Outside-air bypass dampers can be used for part-load operation to minimize overheating, overcooling, and fan energy use. They can also serve to prevent condensation and frosting. Alternatively, you can vary the wheel speed on enthalpy wheels, change the tilt on heat pipes, or vary the flow on run-around loops.

**Redundancy.** Laboratories usually have redundant chillers and boilers to ensure control over a room's climate conditions at all times. If the capacity provided by energy recovery is not accounted for in sizing the chilled water and hot water systems, then the systems should at least be optimized to operate with the lower loads resulting from the use of energy recovery. Otherwise, the chillers and boilers may operate very inefficiently at low part loads.





adopted by all states, although it raises liability concerns for design teams. At the National Institutes of Health (NIH) Louis Stokes Laboratory and the Nidus Center in St. Louis, the general exhaust system is separate from the fume hood exhaust, and there is an enthalpy wheel on the general exhaust. NIH had to use stainless steel ductwork for the fume hood exhaust, because the exhaust was no longer being diluted enough to allow for galvanized ducts.

- The ASHRAE 90.1-2001 energy efficiency standard for nonresidential buildings requires energy recovery on fans of 15,000 cfm or greater in buildings with fume hoods. Laboratories with VAV fume-hood exhaust or direct make-up air for the hoods are exempt. The standard states that the recovery method must have a minimum total effectiveness of 0.5. This is not always achievable, although this caveat is often ignored if a device proves to be cost-effective. Note that the calculation of fan power limitations in the standard includes an adjustment for energy recovery.

## Performance Examples

Air-to-air energy recovery reduces energy use and can significantly reduce heating and cooling system sizes. A large installation of enthalpy wheels done in 1991 at the Johns Hopkins Ross Research Building has resulted in millions of dollars in energy savings. All exhaust, including fume-hood and biological safety cabinet exhaust, is passed through the enthalpy wheels. The equipment paid for itself in first-cost savings because the hot water and chilled water systems could be downsized (see *Engineered Systems*, September 1995). The enthalpy wheels have performed so well that Johns Hopkins is installing enthalpy wheels in its new lab buildings, including the Cancer Research Building shown on the cover of this guide and the Broadway Research Building, scheduled to be completed in early 2004.

In 2002, an energy analysis of enthalpy wheels, heat pipes, and run-around loops was performed for Laboratories for the 21st Century. It analyzed a typical 100,000-square-foot (sf) laboratory in four locations: Minneapolis, Denver, Seattle, and Atlanta. The simulation model assumes a constant-air-volume system (unless otherwise noted in the study). Electricity rates include an energy charge of \$0.03/kilowatt-hour (kWh), an on-peak demand charge of \$7/kW, and an off-peak demand charge of \$4/kW. On-peak hours are 8 a.m. to 10 p.m., Monday through Friday. For natural gas, a rate of \$0.60/therm is assumed. (All studies need to use actual utility rates.) The most significant findings include the following:

- Air-to-air energy recovery reduces gas usage for space heating and reheat for dehumidification by more than 35% in all climates (see Table 1).
- Savings in peak electricity demand associated with an enthalpy wheel depend on climate (see Table 2). No savings are predicted for heat pipes and run-around loops, because the increase in the fan energy demand offsets the decrease in the cooling energy demand associated with these technologies.
- Annual energy cost savings are \$0.27 to \$1.95/cfm of fan air flow (see Table 3). Enthalpy wheels, with sensible and latent heat recovery, appear to be cost-effective in all climates. The cost savings obtained with heat pipes and run-around loops are relatively small in warm, humid climates; however, using these devices as wrap-around loops for dehumidification may be cost-effective.
- Only in the hot, humid climate of Atlanta did annual electricity savings occur with the enthalpy wheel; in the other climates, the increase in annual fan energy offset the annual electricity savings.

**Table 1. Percent Gas Savings (%)**

	Minneapolis	Denver	Seattle	Atlanta
Enthalpy Wheel	65%	58%	49%	48%
Enthalpy Wheel w/VAV	75%	64%	62%	68%
Heat Pipe	41%	36%	41%	36%
Run-Around Loop	44%	36%	42%	38%

**Table 2. Peak Electricity Demand Savings with Enthalpy Wheel (W/sf)**

	Minneapolis	Denver	Seattle	Atlanta
Enthalpy Wheel	3 W/sf	1 W/sf	0	3 W/sf
Enthalpy Wheel w/VAV	3 W/sf	1 W/sf	0	4 W/sf

**Table 3. Annual Energy Cost Savings (\$/cfm/yr)**

	Minneapolis	Denver	Seattle	Atlanta
Enthalpy Wheel	\$1.59	\$0.96	\$0.55	\$0.59
Enthalpy Wheel w/VAV	\$1.95	\$1.19	\$0.82	\$1.00
Heat Pipe	\$0.86	\$0.56	\$0.41	\$0.27
Run-Around Loop	\$0.91	\$0.52	\$0.41	\$0.32



- The greatest reduction (approximately 20%) in chiller size occurs with enthalpy wheels in humid climates; the savings are approximately half this amount with sensible-only recovery devices. In the dry Denver climate, the potential reduction is 10% with all three devices.
- The minimum reduction in boiler size is 15% with any of the devices. If the building is also being humidified in the winter, the additional latent energy recovery with enthalpy wheels results in up to a 50% reduction in heating and humidification requirements.

At the 120,000-sf Fox Chase Cancer Center in Philadelphia, heat pipes with bypass sections were installed in two 30,000-cfm air handling units. The incremental cost for heat pipes with the indirect evaporative cooling option on the exhaust was \$300,000. Anticipated energy cost savings were \$72,510, resulting in a simple payback of 4 years.

## Conclusion

Installing energy recovery systems can substantially reduce the cost and use of energy in laboratories. Selecting an appropriate energy recovery technology, properly designing the system, meeting the applicable codes, and commissioning the system are all important. When an energy recovery system is design, installed and operated correctly it will provide significant energy and environmental benefits.

## Key Terms

**Effectiveness:** The ratio of actual energy recovered to theoretical energy that could be recovered.

**Latent energy:** The energy contained in moisture.

**Latent effectiveness:** Proportional to the ratio of the difference between the humidity ratio of the outside air and the supply air, and the difference between the humidity ratio of the exhaust air and the outside air.

**Sensible energy:** The energy associated with a temperature difference.

**Sensible effectiveness:** Proportional to the ratio of the difference between the dry-bulb temperature of the outside air and supply air, and the difference between the dry-bulb temperature of the exhaust air and the outside air.

**Total effectiveness:** Proportional to the ratio of the difference between the enthalpy of the outside air and the supply air, and the difference between the enthalpy of the exhaust air and the outside air.

## Acknowledgements

We wish to thank the primary author of this guide, Sue Reilly of Enermodal Engineering, Inc. This guide would not have been possible without the additional contributions of Mike Walsh of Vanderweil Engineers, Inc.; Michael Dausch of Johns Hopkins; and John Fisher of SEMCO. Nancy Carlisle, Otto Van Geet, Paula Pitchford, editor, and Susan Sczepanski, graphic designer, all of NREL, also contributed to this best practices guide.

## For More Information

The different types of air-to-air energy recovery devices are discussed in numerous sources. For example, the American Society of Heating, Refrigerating, and Air-Conditioning Engineers (ASHRAE) Handbook of Heating, Ventilating, and Air-Conditioning Systems and Equipment covers a wide range of devices, compares their performance, and identifies appropriate applications. The *ASHRAE Laboratory Design Guide* by McIntosh et al. includes a chapter on energy recovery and discusses laboratory-specific concerns. Also, *A Design Guide for Energy-Efficient Research Laboratories* is available in electronic format from Lawrence Berkeley National Laboratory. This searchable document includes a discussion of different types of energy recovery as well as case studies.

Also, the U.S. Environmental Protection Agency and the U.S. Department of Energy have prepared several *Laboratories for the 21<sup>st</sup> Century* case studies (<http://labs21.lbl.gov/cs.html>). Several case studies feature energy recovery; for an example of enthalpy wheels, see the studies on Pharmacia Building Q, the Nidus Center, and Building 50 at the National Institutes of Health; for an example of heat pipes, see the study on the PETL at Sandia National Laboratories, Albuquerque. Several other good sources of information are listed below.

Air Conditioning and Refrigeration Institute (ARI). 2001. *Air-to-Air Energy Recovery Ventilation Equipment Certified Product Directory*. ARI, Arlington, VA ([www.ARI.org](http://www.ARI.org)).

ARI Standard 1060. 2001. Rating Air-to-Air Energy Recovery Ventilation Equipment. ARI, Arlington, VA.

ANSI/ASHRAE Standard 84-1991 (ARI 1060). 1991. Method of Testing Air-to-Air Heat Exchangers. American Society of Heating, Refrigerating and Air-Conditioning Engineers, Inc., Atlanta, GA ([www.ashrae.org](http://www.ashrae.org)).

Cockerham, K. 2000 (July). "A Tale of Two Systems." *Consulting Specifying Engineer*.

DiBlasio, R. 1995 (September). "Conditioning a Research Facility." *Engineered Systems*.



Gibson, Tom, 1999. "Special Ventilation System Helps Prevent Release of Dangerous Agents at Georgia State," *The News: Air Conditioning, Heating and Refrigeration*.

International Code Council, 2003. International Mechanical Code. ICC, Falls Church, VA.

McIntosh, I.; Dorgan, C.B.; and Dorgan, C.E., 2001. *ASHRAE Laboratory Design Guide*. American Society of Heating, Refrigerating and Air-Conditioning Engineers, Inc., Atlanta, GA.

National Fire Protection Association 45, 2001. Standard on Fire Protection for Laboratories Using Chemicals. NFPA, Quincy, MA.

National Wildlife Federation, 2002. Emory University *Campus Ecology Yearbook* 2001-2002. NWF, Reston, VA.

Paarporn, S., P.E., 1999. "Run-around Loop Heat Recovery with Dehumidification System." *ASHRAE Journal*, June.

Reilly, S., and Van Geet, O., 2003. *Laboratories for the 21st Century Energy Analysis*. U.S. Environmental Protection Agency and U.S. Department of Energy Federal Energy Management Program, Publication No. DOE/GO-102003-1694. Prepared by the National Renewable Energy Laboratory, Golden, CO, [http://labs21.lbl.gov/docs/labs21energyanal\\_33410.pdf](http://labs21.lbl.gov/docs/labs21energyanal_33410.pdf).

### ***On Laboratories for the 21st Century:***

Phil Wirdzek  
U.S. Environmental Protection Agency  
1200 Pennsylvania Ave., N.W.  
Washington, DC 20460  
202-564-2094  
[wirdzek.phil@epamail.epa.gov](mailto:wirdzek.phil@epamail.epa.gov)

Will Lintner, P.E.  
U.S. Department of Energy  
Federal Energy Management Program  
1000 Independence Ave., S.W.  
Washington, DC 20585  
202-586-3120  
[william.lintner@ee.doe.gov](mailto:william.lintner@ee.doe.gov)

### ***On Energy Recovery:***

Otto Van Geet, P.E.  
National Renewable Energy Laboratory  
1617 Cole Blvd.  
Golden, CO 80401  
303-384-7369  
[otto\\_vangeet@nrel.gov](mailto:otto_vangeet@nrel.gov)

Sue Reilly, P.E.  
Enermodal Engineering, Inc.  
1554 Emerson Street  
Denver, CO 80218  
303-861-2070  
[eeinc7@qwest.net](mailto:eeinc7@qwest.net)



### **Laboratories for the 21st Century**

U.S. Environmental Protection Agency  
Office of Administration and Resources Management  
[www.epa.gov/labs21century/](http://www.epa.gov/labs21century/)



In partnership with the  
U.S. Department of Energy  
Energy Efficiency and Renewable Energy  
*Bringing you a prosperous future where energy  
is clean, abundant, reliable, and affordable*  
[www.eere.energy.gov/](http://www.eere.energy.gov/)

Prepared at the  
National Renewable Energy Laboratory  
A DOE national laboratory

DOE/GO-102003-1774  
October 2003

Printed with a renewable-source ink on paper containing at least  
50% wastepaper, including 20% postconsumer waste