

Immunity in Stressed Astronauts • Development in Zebrafish • Flywheels • Granular Flows

# Space Research

Office of Biological and Physical Research

December 2002, Vol. 2 No. 1

## Research: Breaking Flight Barriers

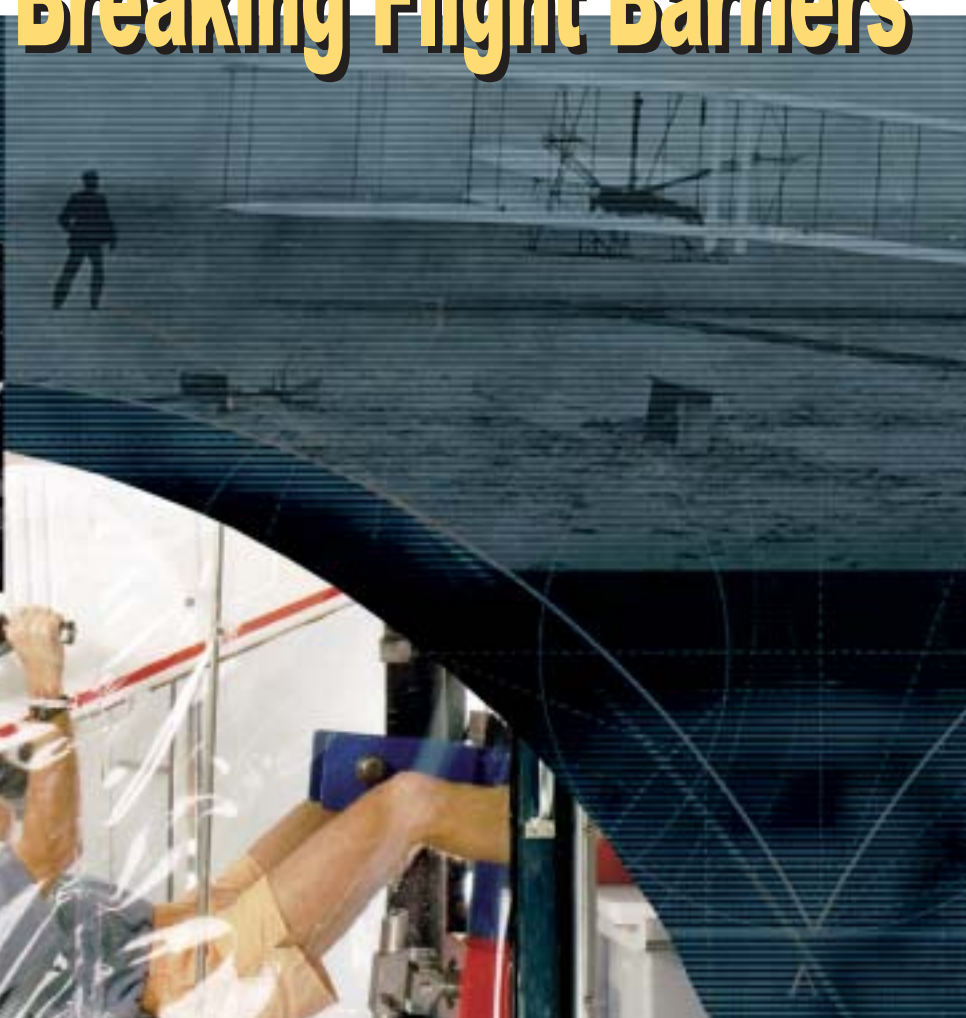
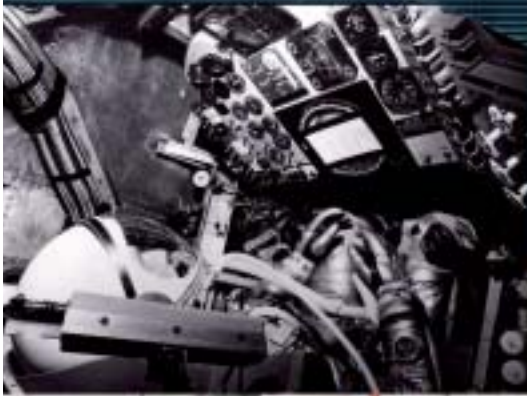

Profile:  
**Rafat  
Ansari**



National Aeronautics and  
Space Administration

# Letter From the Associate Administrator



**A**s Orville Wright began the world's first controlled, powered flight carrying a pilot onboard, he faced a cold December wind. The 27-mile-an-hour currents buffeted his Wright Flyer along a 120-foot, 12-second journey of erratic climbs of up to 10 feet off the ground followed by sudden pitches, but Wright maintained control of the craft and landed it safely. His Flyer was designed to protect its pilot, including giving him more horizontal control in case of an engine stall, and the only physiological effect Wright experienced after his momentous flight was being chilled. This he remedied by warming up with brother Wilbur Wright and their safety crew in a nearby building.

Throughout the history of flight, great attention has been paid to the safety of pilots, their crews, and their passengers, and scientific research has made safe air travel a reality. Cabins have been pressurized to allow humans to travel at higher altitudes; cockpits have been made more user-friendly; and stronger materials have been developed for aircraft, to name a few advances. More recently, with humans traveling in space, scientific research has resulted in progress toward materials that better shield humans from radiation; toward countermeasures that lessen bone loss and muscle atrophy from travel in a microgravity environment; and toward spacecraft environments that are more user friendly for crews of various nationalities, among several other areas of research.

We still have a lot to learn to protect spaceflight crews — especially those who will travel on long-term missions — so, under the auspices of NASA's Office of Biological and Physical Research (OBPR), the Office of Spaceflight, and the Office of the Chief Health and Medical Officer, researchers at Johnson Space Center and the National Space Biomedical Research Institute joined to write the Critical Path Roadmap. This document outlines the physiological risks of long-term spaceflight and the direction of research and technology development needed to minimize those risks. Ongoing and new research will need to address issues related to advanced life support, such as how to provide and recover potable water; issues regarding bone loss, such as how to minimize and reverse that loss; and issues related to changes in the cardiovascular system, such as how to prevent or reduce the occurrence of serious cardiac dysrhythmias.

Research also will need to address environmental health issues, such as how to control potential sources of air or water pollution; food and nutrition issues, such as defining the nutritional requirements for exploration missions; and issues in human behavior and performance risks, such as finding what behaviors, experiences, personality traits, and leadership styles in crewmembers optimize performance. In addition, issues will need to be addressed in immunology, infection, and hematology, such as finding countermeasures for spaceflight-associated compromises in immune systems; in muscle alterations and atrophy, such as finding out what exercises optimize skeletal muscle performance; and in neurovestibular adaptation, such as determining the pros and cons of artificial gravity as a countermeasure.

Using better materials to minimize radiation exposure will need to be studied, too, as will issues regarding clinical capabilities, such as determining what medical imaging and telemedicine capabilities are necessary to support space medicine. And, of course, multisystem, or cross-risk, issues such as learning how changes in the cardiovascular system affect other systems must be addressed. (For more information on the Critical Path Report, look on the World Wide Web at [http://criticalpath.jsc.nasa.gov/NS\\_main.asp](http://criticalpath.jsc.nasa.gov/NS_main.asp).)

So, as we look back with pride and amazement at the significance of a 12-second flight taken 100 years ago, we also acknowledge the responsibility we have to move ahead. It is only a matter of time before we once again break the boundaries of low Earth orbit, and the future of safe space travel rests largely on the shoulders of the researchers who must lay the needed scientific and technological foundations. The fact that we can talk in these terms today is due largely to the legacy of the Wright brothers. I hope that future generations will look back to our work in OBPR as a legacy that enables them to advance space travel, too.

A handwritten signature in black ink that reads "Mary E. Kicza". The signature is fluid and cursive.

Mary Kicza  
Associate Administrator  
Office of Biological and Physical Research

# Table of Contents

## Hampton University NASA Biological and Physical Research Outreach Project

### Hampton University/NASA MSFC

1040 D Settlers Landing Road  
Hampton, VA 23669  
Telephone: (757) 723-2197  
Fax: (757) 723-0241

#### Staff

Julie Moberly  
project manager

Julie K. Poudrier  
assistant project manager

Carolyn Carter Snare  
senior technical writer

Rosa Jaqueline Edwards  
electronic media specialist

Teresa M. Jones  
administrative assistant

#### Contributing Editors

Trudy E. Bell

Jacqueline Freeman-Hathaway

Chris McLemore

Katherine Rawson

#### Editorial Board

Kristen Erickson (chair)

Bradley Carpenter

John Emond

Guy Fogleman

David Liskowsky

Bonnie McClain

Alexander Pline

Dan Woodard

#### Student Intern

Mitchell Artis  
senior, computer science

#### On the cover:

The Wright brothers pushed the limits of human safety when they made the first successful powered flight 100 years ago (top right). Their legacy has carried over to space, where people still are pushing limits and breaking barriers. Pictured are Astronaut Scott Carpenter during centrifuge training for the Mercury-Atlas 7 mission (top left) and contract engineer Phil Culbertson in the Extra Vehicular Activity Exercise Device, which is used to evaluate the effects of microgravity on astronauts for long-duration spaceflight (bottom). credit: NASA

**Letter From the Associate Administrator** 2

**Spotlight** 4

**The Wright Stuff: How Research Breaks Barriers to Flight on Earth and Beyond** 6

*As the 100th anniversary of powered human flight approaches, Space Research reviews how far we have come in challenging the boundaries of air and space and how the Office of Biological and Physical Research is part of our continuing journey to explore new frontiers in space.*

#### Research Updates:

**In Sickness and in Health: Immunity and the Stressed Astronaut** 12

*What is the reaction of the human immune system to the stresses of space-flight? Two pioneering microbiology experiments on STS-107 may help our understanding.*

**Fishing for Clues: A Common Tropical Fish Makes Its Contribution to Science** 14

*One small black-and-white fish is making huge contributions to developmental neurobiology. Researchers like Stephen Moorman are using zebrafish to understand critical periods of development that are common to all vertebrate species.*

**Shake, Rattle, and Roll: Figuring Out Granular Flows** 16

*Watching how beads collide in space may help quantify how grains of wheat, plastic pellets, pharmaceutical capsules, and avalanches all flow on Earth.*

**From Child's Toy to ISS: Flywheels Hold the Power** 18

*Flywheel energy storage systems are under development to provide a more efficient and cost-effective alternative to electrochemical batteries in spacecraft, as well as in cars and other everyday applications.*

#### Education & Outreach:

**DIME Pays Off for Youth** 20

*Students who want to run experiments in microgravity earn profitable knowledge from NASA's DIME program.*

**Meetings, Etc.** 22

**Profile: Rafat Ansari** 27

*A career in fluid physics has led Rafat Ansari to develop technology that has benefited NASA research and become a new tool for diagnosing cataracts.*

Space Research is published quarterly by the **Marshall Space Flight Center (MSFC)** in conjunction with **Hampton University** and **Infinity Technology Inc.** Address comments, newsletter requests, and mailing list updates to Coordinator, Microgravity Research Program Office, Bldg. 4201, SD13, Marshall Space Flight Center, AL 35812. Please provide your name, title, address, and phone number.

E-mail address: [john.emond@hq.nasa.gov](mailto:john.emond@hq.nasa.gov)

Space Research: [http://spaceresearch.nasa.gov/general\\_info/prespublic.html#newsletters](http://spaceresearch.nasa.gov/general_info/prespublic.html#newsletters)

Office of Biological and Physical Research: <http://spaceresearch.nasa.gov>



## Message in a Bottle: Will Xenon Explain Shear Thinning?

In an effort to discover how a complex fluid such as ketchup can suddenly go from thick to thin during pouring, Principal Investigators Robert Berg and

Michael Moldover of the National Institute of Standards and Technology (NIST) have designed an experiment called Critical Viscosity of Xenon-2 (CVX-2) that is scheduled to fly on STS-107.

Scientists call the decrease in viscosity of a fluid as it is stirred “shear thinning.” When a fluid is being sheared, fluid layers slide over each other in response to a shearing stress that makes different layers move with different velocities. But how does that change the viscosity of a simple fluid like xenon, a chemically inert gas? According to Berg, “Shear thinning depends on interactions at the molecular level that are still poorly understood.” The xenon measurements will help scientists better understand the connection between molecular interactions and shear thinning. This information may help manufacturers who use materials that shear thin (such as molten chocolate, ketchup, or paint) and need to know how such materials flow in order to design production processes.

CVX-2 will study shear thinning in xenon near its critical point, where

temperature and pressure are such that a substance exists in a state that is simultaneously close to both liquid and gas. Scientists are hoping that if they can force xenon to its critical point, they can make it display shear thinning and discover more about the fundamentals of this phenomenon.

When such experiments are done on Earth, gravity causes the gas to compress under its own weight and thus develop differential densities. In low gravity, the effect of the gas’s own weight is dramatically reduced. CVX-2 will try to create shear-thinning behavior by measuring the viscosity of a sample of xenon while the temperature and pressure are steered into the critical region. This will give Berg and Moldover a new window into fluid behavior.

For more information on CVX-2, visit <http://microgravity.grc.nasa.gov/cvx2/> on the World Wide Web. For additional information on fluid science research at NIST, see <http://properties.nist.gov/fluidsci/>.

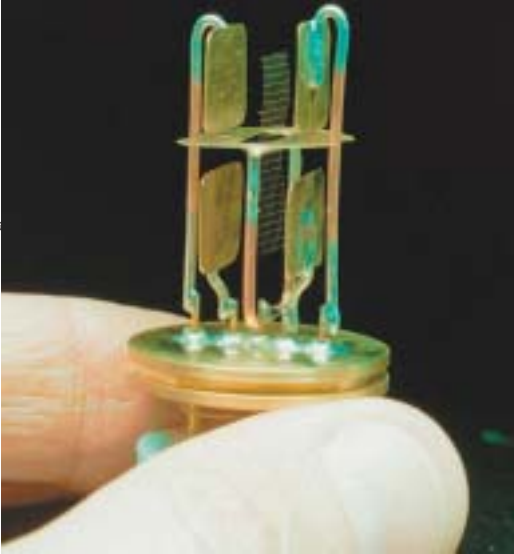

credit: National Institute of Standards and Technology

The CVX-2 experiment, slated to fly on STS-107, will control the temperature and pressure of a sample of xenon, forcing the element toward its critical point. Once it is there, a delicate screen paddle surrounded by electrodes will stir the xenon sample in an effort to induce shear thinning.

## Whitson Named First ISS Science Officer

In September 2002, NASA Administrator Sean O’Keefe named Expedition 5 Flight Engineer Peggy Whitson as the first NASA International Space Station (ISS) science officer.

Whitson, who received her doctorate in biochemistry from Rice University in Houston, Texas, became the station’s first resident scientist when she arrived on the ISS in June 2002. In naming an ISS science officer, O’Keefe is emphasizing the space station’s main mission: scientific research. He says, “Dr. Whitson is an obvious choice for NASA’s first ISS science officer. She has dedicated her career to the pursuit of scientific knowledge, and she recognizes that

some of the problems we face today here on Earth have answers that will be discovered in future activities on the International Space Station.”

Before joining the astronaut corps in 1996, Whitson conducted research at Johnson Space Center in Houston, was project scientist for the Shuttle-Mir Program, and was co-chair of the U.S.–Russian Mission Science Working Group. In addition to her duties as flight engineer and science officer, Whitson conducted her own research on renal stone risk assessment on the space station.

As ISS science officer, Whitson, who recently returned to Earth on STS-113,

focused on U.S. research conducted on the space station, working with the research community to help each experiment achieve maximum research returns. Her postflight duties will include participating in debriefings with principal investigators and collaborating with them during their analysis of experiment results. Whitson also communicated to the public her experiences as a researcher aboard the ISS.

For more information on Peggy Whitson, see the profile in *Space Research*, Vol. 1, No.1, page 27. She can be reached at [peggy.a.whitson1@jsc.nasa.gov](mailto:peggy.a.whitson1@jsc.nasa.gov).

# Life Sciences PIs Receive Awards

Two principal investigators in the Office of Biological and Physical Research have been recognized for their research in the life sciences. Emily Holton, a scientist at Ames Research Center (ARC), was awarded the H. Julian Allen Award for her hindlimb suspension model for simulated microgravity, and Muriel Ross, a researcher in the telemedicine program at the University of New Mexico, received a Bárány Society medal for her research on the vestibular system.

Holton received the 2001 award in recognition of her 1979 paper "Spaceflight and Bone Turnover: Correlation with a New Rat Model of Weightlessness." The model that her lab created for simulating a microgravity environment for rats is now a well recognized means of studying how physiological phenomena can change when mechanical loading of the hindlimbs is minimized. In fact, in the past six years, almost 400 papers referencing this model have been published. "The excitement [about the recognition] is realizing that you have made a unique contribution to science," Holton says.

The H. Julian Allen Award, established in 1969, recognizes the published scientific or engineering paper of outstanding technical merit that has had a significant impact on its field. Allen served as director of ARC from 1965 to 1969.

Ross received her 2002 Bárány Society Hallpike-Nylén medal in recognition of her research on the peripheral vestibular system of rats. This research, which was flown on the first and second Spacelab Sciences missions in 1991 and 1993, respectively, provided data on the basic organization of the vestibular macular organs. Maculae are sensors of gravity and other linear accelerations. The study was later flown on the Neurolab mission in 1998 to further define the data.

The international Bárány Society was founded in 1960 to honor the memory of the late Robert Bárány, who was professor of Oto-Rhino-Laryngology (ear, nose, and throat) at the University of Uppsala, Sweden from 1929 to 1936. The Bárány Society's aim is to increase contact between scientists engaged in vestibular research and to stimulate otoneurological (inner ear neural) research.

Ross was also recently added to the University of Michigan's Hall of Fame in recognition of her numerous accomplishments in scientific research and education.

For more information on the Holton's research, go to [http://peer1.nasaprs.com/cfpro/peer\\_review/lbt1\\_97.cfn?id=168](http://peer1.nasaprs.com/cfpro/peer_review/lbt1_97.cfn?id=168) on the World Wide Web. For information on Ross's research, go to [http://peer1.nasaprs.com/cfpro/peer\\_review/lbt1\\_00.cfn?id=25](http://peer1.nasaprs.com/cfpro/peer_review/lbt1_00.cfn?id=25).



credit: NASA

Emily Holton



credit: NASA

Muriel Ross

## Office of Biological and Physical Research Creates New Division

OBPR's Research Integration Division at NASA headquarters has become two divisions: Space Product Development and Mission Integration. OBPR established the Space Product Development Division in recognition of the fact that the commercial research

sponsored by OBPR, largely through the commercial space center program, requires separate division status to allow concentration on commercial space research challenges, opportunities, and long-range planning. The Mission Integration Division will

continue the important manifesting and payload configuration management activities for OBPR payloads on the space shuttle and the International Space Station that were performed by the previous Research Integration Division.



# The Wright Stuff: How Research Breaks Barriers to

As the 100th anniversary of powered human flight approaches, Space Research reviews how far we have come in challenging the boundaries of air and space and how the Office of Biological and Physical Research is part of our continuing journey to explore new frontiers in space.

**H**umans have always been fascinated by flight. The mythology of the ancient Greeks included the story of Daedalus, an imprisoned inventor who fashioned wings of wax and feathers to escape imprisonment. He taught his son Icarus, also imprisoned, how to fly using these wings, but cautioned him that during their escape Icarus must fly neither too close to the water, for his wings would become waterlogged, nor too close to the Sun, for the wings' wax would melt. As father and son flew to freedom, Icarus's joy at being able to fly caused him to forget his father's warnings, and he soared toward the Sun, with tragic results. The wax melted from his wings, and he plunged to his death in the sea below. The ancient Greeks could not have known that the myth of Daedalus, and its broader theme of risk taking, foreshadowed the dangers and triumphs of flight in the 20th century.

## Fancying Flight

While humans have long dreamed of flying, powered flight did not become a reality until December 17, 1903, when brothers Wilbur and Orville Wright made history with the first sustained, controlled flight in a powered aircraft carrying a person, on the sand dunes of Kitty Hawk on the North Carolina Outer Banks.

According to Roger Launius, former NASA chief historian, who now works in the Department of Space

History at the Smithsonian Institution's National Air and Space Museum, although the Wrights' flight was first, others had been experimenting with kites and gliders for some time. "There was a cadre of people," says Launius, "going back to the 1850s, trying to make flight happen. Otto Lilienthal got the Wrights' attention with his glider experiments in Germany in the late 1800s." Lilienthal completed more than 2,000 glider flights before dying in a glider accident in 1896.

There was no way to actively control gliders during flight, and that lack of control ultimately led to Lilienthal's fatal crash from a height of 50 feet. The fact that Lilienthal's death was front-page news testified to the public interest in flying; Lilienthal's death also presaged the need to consider how humans would interact with the machines they would fly so that they could remain safe during flight.

## Spurred to Flight

"Lilienthal's death was one of the events that really prompted the Wrights to pursue flight," says Launius. But the Wrights did not immediately begin to design or build an airplane. Instead, they studied Lilienthal's works, as well as those of Octave Chanute, a self-taught engineer. In 1894, Chanute published *Progress in Flying Machines*, in which he assembled all the available data on flight experiments. Chanute believed that successful flight would require the work of numerous experimenters. The Wright brothers corresponded with Chanute, who became their friend and mentor. The Wrights also consulted the Smithsonian Institution in Washington, D.C., which sent them a reading list and encouraged them to press on.

The Wrights did press on. "They recognized that the most important question was one of control — once in the air, how do you control the aircraft?" says Launius. In 1899, they tried out their idea of "wing warping" as a means of controlling a flying kite. Wing warping allowed for three-axis control: side-to-side, up-and-down, and front-to-back (yaw), and it worked. The Wrights decided that they would next try their wing warping on a glider and finally on a powered plane.

The Wrights chose Kitty Hawk for their first attempts at powered flight for several reasons. "When they were ready to try flying," Launius continues,

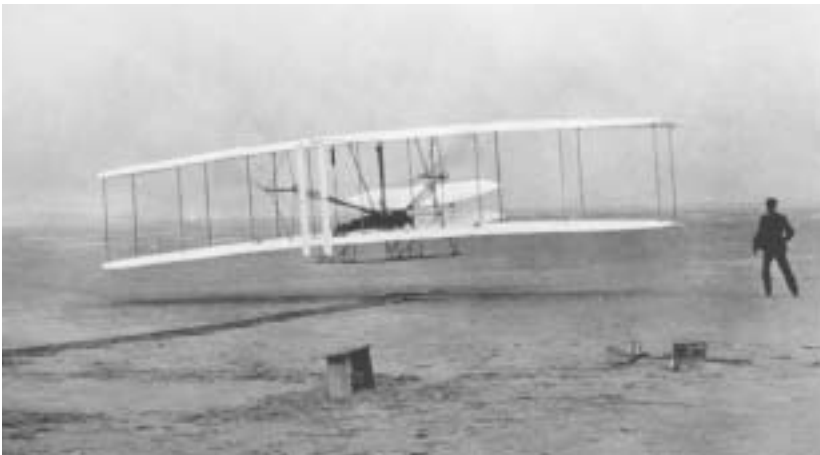

credit: NASA

On December 17, 1903, Wilbur and Orville Wright made the first successful powered airplane flight off the sand dunes of Kitty Hawk, North Carolina, setting the stage for development of commercial aviation and later spaceflight.

# Flight on Earth and Beyond

“they wrote to the U.S. Weather Bureau for information on places that could provide a stable breeze. Kitty Hawk, with its year-round Atlantic Ocean breezes of 20–25 knots, was one of the locations that the bureau suggested.”

Kitty Hawk had additional advantages: The sand dunes provided hills from which to launch, and the sand offered a soft landing. The Wrights, who lived in Dayton, Ohio, traveled frequently to Kitty Hawk from 1900 to 1903, their efforts culminating in a successful first flight on December 17, 1903. Says Laninius, “The Wrights’ plane could barely fly, to be honest. [The distance they flew was just 120 feet.] But they proved their ideas about wing warping, and by 1905 they had built the first practical airplane. Back in Ohio, they could take off from Huffman Prairie, do figure eights, fly over the city, and then fly back out to the prairie to land. Wing warping gave them total control, and it was something that others couldn’t duplicate.”

Says NASA Chief Medical Officer Richard Williams, “By the time of powered flight, humans had already been exposed to most [physiological] problems associated with flight, such as high altitudes (see sidebar, “Up, Up, and Away”), so powered flight simply increased the opportunities and broadened the horizons for additional problems.” During one of the Wrights’ demonstrations for the U.S. Army, powered flight suffered its first fatality. In 1908 during a test flight of the Wright Flyer at Fort Myer, Virginia, Orville Wright put the plane into a steep turn. One of the plane’s propeller blades (a new propeller, not yet tested for flight) snapped off and the plane crashed. Wright’s passenger, Lt. Thomas Selfridge, died of massive head injuries. The Army Medical Corps investigated the accident and later recommended to the Army that all aviators wear helmets for head protection.

## From Pony Express to Air Express

While the Wright brothers could not interest the United States War Department in the results of their flight research, the Postal Service recognized its value and authorized the first experimental airmail flight in 1911.

## Up, Up, and Away

In the 18th century, balloons were the means by which humans first took to the air. The early balloonists were the first to conduct physiological studies of the effects of flight on humans and animals.

In June 1783, Joseph and Etienne Montgolfier successfully flew a hot air balloon constructed of paper and linen. After several more test flights, the brothers sent aloft three passengers — a duck, a rooster, and a sheep — to be sure it was safe before sending humans. The animals returned to Earth unharmed, except for the rooster, whose wing had been broken by the sheep.

On November 21, 1783, a physicist named Jean-François Pilatre de Rozier and an army major, Marquis François d’Arlandes, flew for 25 minutes in a Montgolfier balloon. In December of that same year, Jacques Charles made the first flight in a balloon filled with hydrogen. The flight lasted more than two hours, during which time Charles landed to let off his passenger and then re-ascended to a height of about 9,000 feet.

Ballooning captured the interest of would-be flyers worldwide, and experiments took place all over Europe. In January 1785, Jean-Pierre Blanchard and Dr. John Jeffries crossed the English Channel in a balloon. The first ballooning fatality occurred just six months later when Pilatre de Rozier attempted a crossing of the English Channel in the opposite direction (from France). He had designed a new balloon that combined the designs of the Montgolfiers and Charles, using a flame to heat the hydrogen gas in a balloon. The flame ignited the hydrogen, resulting in an explosion that killed both Pilatre de Rozier and his passenger.

Says NASA Chief Medical Officer Richard Williams, “By the early 1800s, ballooning was at its peak, and balloonists were trying to reach higher altitudes.” Because no one knew how humans might be affected by going ever higher into the atmosphere, balloonists also began to document physiological changes that took place during flight. “In the 1790s, Blanchard, who had traveled to America, ascended to high altitude in a balloon while American physician Benjamin

Rush recorded changes in Blanchard’s mental status, as well as cold injury, rapid pulse, and nosebleeds,” says Williams.

Balloonists continued to try to attain ever-greater heights. In 1862, the British Association for the Advancement of Science decided to fund studies of the upper atmosphere, which would be reached by balloon. Scientist James Glaisher and balloon pilot Henry Coxwell volunteered for these flights, making 28 flights between 1862 and 1866. In July 1862, Glaisher and Coxwell reached an altitude of 26,000 feet without oxygen. In September, they reached an altitude of nearly 30,000 feet, a feat that nearly killed them. Glaisher made a detailed account of this flight, keeping track of the temperature and dew point as they ascended, and even of the times at which he began to have difficulty seeing, when he began to have difficulty controlling his limbs, until he passed out.

Fortunately for both balloonists, when Coxwell noticed that Glaisher was unconscious and recognized the danger they were in, despite having lost the use of his hands from the cold, he managed to open the valve of the balloon with his teeth so that they could descend. Neither man suffered any lasting effects from their exposure to an altitude of nearly seven miles.

Thirteen years later the French balloonists who attempted several high-altitude balloon flights for scientific purposes as well as to break Glaisher’s record were not so lucky. Pilot Théodore Sivel, assisted by engineer Joseph Crocé-Spinelli and passenger Gaston Tissandier, ascended in a balloon named *Zenith*. Sivel and Crocé-Spinelli had consulted with Paul Bert, a professor of physiology in Paris, regarding oxygen starvation at high altitudes. When the men ascended in *Zenith*, they had with them bags of superoxygenated air with hoses attached through which they could breathe as needed. As Glaisher and Coxwell had experienced, the three men struggled to remain conscious at an altitude of about 24,000 feet. Tragically, both Sivel and Crocé-Spinelli died of asphyxiation, despite the presence of the bags of oxygenated air nearby.





credit: NASA

The National Advisory Committee for Aeronautics was established in 1915 to find solutions to the problems of flight. Orville Wright, the NACA's longest serving member, is the sixth person from the left in this photo of the committee taken in 1938.

At the time of the nascent airmail service, general public interest in aeronautics was also growing. As early as 1911, at the first meeting of the American Aeronautical Society, members expressed interest in development of a national aeronautical laboratory. Then in 1915, as Americans continued to hear about the use of airplanes in what would later be known as World War I, the United States Congress created the National Advisory Committee for Aeronautics (NACA). The NACA was established as an advisory committee to help find practical solutions to the problems of flight. Orville Wright was one of the original 12 committee members and ultimately served longer than any other member.

Regular airmail flights began in May 1918, with scheduled service between New York City and Washington, D.C. "The push for airmail was led by the private sector, namely banks," says Launius. "Banks wanted same-day service. Back then, money to cover a check that was written on a New York bank and cashed in San Francisco could take a week to travel from New York to California."

On February 22, 1921, mail was flown from New York City to San Francisco, with planes flying legs of the journey both during the day and the night.

Congress appropriated additional money for the Postal Service, which then established more airfields with towers, beacons, searchlights, and boundary markers. The Postal Service also equipped its planes with luminescent instruments, navigation lights, and parachute flares, and it began installing radio stations at the cross-country airfields so that pilots could obtain up-to-date weather information. The Postal Service, while ensuring the safety of pilots, was establishing the necessary infrastructure for commercial flight in the United States.

In 1925, Congress passed a law to encourage commercial aviation and authorized the Postmaster General to contract for airmail services. "By 1926, the Postal Service had relinquished control of its aviation infrastructure to the Department of Commerce," says Launius. "Much of that infrastructure became what is now the Federal Aviation Administration."

Just a year after Congress expressed a desire to commercialize air flight, the first commercial scheduled flight in the United States took place in 1926, with a route from Los Angeles to Salt Lake City. Commercialization had become a reality, largely with the help of NACA-sponsored research.

## The Advent of Medical Standards

As the use of flying machines evolved, so too did the understanding of the human element. Says Williams, "A physiologically significant event in aviation came during World War I when the aviation departments of the various antagonists began to set medical standards for pilots — it was thought that nearly perfect physiology was required to be able to manage the complex task of flying an airplane. The British reviewed their flight casualty list after the first year of the war and found that the majority of deaths were the result of carelessness in one form or another." This review led the British to institute medical standards, and the rest of the war's participants followed suit.

Medical standards continued to develop between the world wars. One standard was the "needle test," in which a loud noise was made to startle a pilot who held a needle end-to-end between two fingers. If the test subject pricked himself with the needle, then he was considered too easily startled to make a good pilot. Another test was the "mallet test." The test subject was hit with a mallet, and if he remained incoherent for more than 15 seconds he wasn't considered suitable for flying. "These early tests, bizarre by today's standards, reflected lack of understanding of the true demands of flight," says Williams. "Medical testing was excessive, by today's standards, prior to the first flight of humans in space as well, again reflecting lack of understanding of the physiology of space flight." But aerospace medicine was still in the future, for between the wars, the concept of spaceflight was the province of dreamers (see sidebar, "Rocket Man").

## Birth of Aviation Medicine

The decades between the two world wars did see more notable improvements in safety measures for pilots. As planes flew higher and faster, in-flight oxygen-delivery equipment, first used by high-altitude balloonists, was refined. Medical standards were instituted for civilian pilots. As the Federal Aviation Administration became more established, a medical branch was developed to help ensure that pilots had no major physical limitations.

In 1918, the Medical Research Laboratory of the Army Air Service, Mineola, New York, graduated its first flight surgeon, Colonel Theodore Lyster. In 1925, the facility in Mineola was renamed the School of Aviation Medicine. Says Williams, "Louis Bauer was the



first commandant of the School of Aviation Medicine. He was responsible for proposing both military and civilian medical standards [for pilots] and is considered the founder of aviation medicine in the United States.”

The Air Force, too, had a School of Aviation Medicine, located outside of San Antonio, Texas. The school’s first commandant was Col. Harry Armstrong, who authored the classic text *The Principles and Practice of Aviation Medicine*. Armstrong also was the first person to understand the need for pressurization in airplanes to allow them to fly above 40,000 feet.

During the 1930s and 1940s, research advances were made in oxygen-delivery systems, electrically heated garments to counteract the extreme cold at high altitudes, g suits to protect pilots experiencing extreme forces during combat, and ways to manage air sickness.

In 1934, Wiley Post, the first pilot to fly solo around the world, decided he wanted to focus on high-altitude flight. The cockpit of his plane, *Winnie Mae*, could not be pressurized, so he developed, with the help of the B.F. Goodrich Company, a pressurized suit with a liquid oxygen breathing system. In test flights over Chicago, Post flew to heights greater than 40,000 feet, in the process discovering the jet stream.

The first U.S. centrifuge for human g-force testing was built at Wright Field in Dayton, Ohio, in 1936 (the Germans had developed two centrifuges in 1918). A fledgling human factors field also developed in the 1940s, with scientists studying how humans could work on multiple tasks simultaneously in a complex environment like an airplane cockpit.

In the late 1940s and early 1950s, test pilot Chuck Yeager broke speed records, culminating with a speed of 1,650 miles per hour in 1953. Yeager’s flight surgeon, John Stapp, followed the lead of self-experimenting balloonists who had gone before. He experimented with rocket sleds, traveling at speeds of over 600 miles per hour to test the effects of acceleration and deceleration on his own body.

In 1948, Armstrong organized a symposium to discuss the aeromedical problems of space travel. That symposium marked the first formal approach to the study of the medical hazards of spaceflight (such as cold, lack of oxygen, and the boiling of body fluids), and it was there that German aeromedical specialist Hubertus Strughold coined the term “space medicine.”

All of this research laid the foundation for putting humans into space and bringing them home again safely.

## Sending Up Satellites

But before humans could fly into space, the world would need to place a craft, such as a satellite, into orbit. In 1955, the United States and the Soviet Union announced plans to orbit a satellite for the International Geophysical Year (1957–1958).

To the dismay of the American public, while the U.S. satellite was in its final development, the Soviet Union successfully launched *Sputnik 1* on October 4, 1957. *Sputnik 2* was launched just a month later, carrying the first animal into orbit, a dog named Laika. The Americans managed a successful satellite launch, *Explorer 1*, on January 31, 1958, followed by a second successful launch, of *Vanguard 1*, in March.

Shortly after the launch of *Sputnik 1*, the Senate had begun hearings to review the U.S. defense and space programs. Out of these hearings came the decision to establish a national space program. The president and Congress reached consensus on a civilian-based, research-oriented national space agency, with the NACA at its core. Says Launius, “The NACA also had another distinct advantage: It was nonmilitarized, and therefore a nonthreatening organization. This was important because of the whole Sputnik issue — the new organization was not to be seen as a threat by the Soviets.” In July 1958, President Dwight Eisenhower signed into law the National Aeronautics and Space Act. The act charged the new agency with civilian aeronautical and space research, with a distinct requirement for disseminating information and commercializing space. Thus, the National Aeronautics and Space Administration was born.

## To the Moon and Beyond

That NASA was foremost a civilian research agency in no way forestalled the continuing technological race between the United States and the Soviet Union. Although the United States had lost the satellite race, as well as the race to be the first to put a human into orbit around Earth (a feat performed by the Soviet Union’s Yuri Gagarin in

## Rocket Man

While the science of aeronautics was enjoying public interest and revolutionary growth at the beginning of the 20th century, aficionados of spaceflight were viewed as cranks and lunatics. But public perception did not stop those dreamers from pursuing their interests.

After earning a doctorate in physics in 1911, Clark University professor Robert Goddard regaled his physics students with his ideas on how to reach the Moon. In 1920, the Smithsonian Institution published Goddard’s monograph, *A Method of Attaining Extreme Altitudes*, which described how a small rocket might travel from Earth to the Moon, detonating flash powder on impact so that observers with telescopes could verify the Moon landing. Goddard’s work was generally met with public ridicule, and Goddard, who was naturally reticent, shied away from any further publicity.

But Goddard did not stop his rocket research, and on March 16, 1926, he successfully launched the first liquid-propellant rocket. Charles Lindbergh took note of his work and brought it to the attention of the Guggenheim Fund, ultimately convincing the fund to support Goddard’s research. Goddard used the support to set up a research facility near Roswell, New Mexico, where he and his assistants, laboring in secrecy, developed increasingly larger and more complex rockets. Goddard did not publicize his research until 1936, when the Smithsonian Institution published his second monograph, *Liquid Propellant Rocket Development*.



credit: NASA

Robert Goddard, seen here in the early 1930s transporting one of his rockets behind a Model A Ford truck to his test site near Roswell, New Mexico, was a leader in U.S. rocketry research and one of the pioneers of the theoretical exploration of space.





credit: NASA

Computer-generated models help human factors researchers address ways that crewmembers can interact effectively with their surroundings. This model simulates a crewmember at a station research rack and factors in variables such as restraints, human reach, and vision.

April 1961 with a flight time of a little less than two hours), the nation was determined to win the race to put humans on the Moon.

John Glenn followed Gagarin into orbit in February 1962 aboard the *Friendship 7* Mercury capsule, spending nearly five hours in the microgravity environment of space. In preparation for his flight, Glenn had spent time at Lewis Research Center (now Glenn Research Center) in 1960 in the Multiple Axis Space Test Inertia Facility, a three-axis gimbal rig that simulated tumble-type maneuvers that could be encountered in space flight. The gimbal rig, like the human centrifuge and the rocket sleds, was a test facility designed to prepare humans for forces they might encounter in space as well as to aid researchers in developing countermeasures for those forces. (Glenn later flew as a payload specialist aboard the Space Shuttle *Discovery* on STS-95 in 1998, at 77 becoming the oldest astronaut

and the oldest cardiovascular research subject to go into space.)

On July 20, 1969, the United States won the race to the Moon when Neil Armstrong and Buzz Aldrin exited their *Apollo 11* lunar lander and planted an American flag in the lunar soil. NASA followed the success of the Apollo missions with *Skylab*, a temporary space station based on Apollo hardware and systems. In 1972, the space shuttle program was approved. One of the space shuttle's primary uses would be as a research facility, and for that purpose Spacelab was built. Spacelab included a pressurized laboratory module that fit in the space shuttle's payload bay, providing an environment for hands-on research. Over its 17-year flight history, the Spacelab program hosted payloads for practically every research discipline that NASA pursues and enabled the international research community to learn to cooperate on research of mutual interest and to share and disseminate data.

In the early 1980s, President Ronald Reagan announced that the United States, along with international partners, would build a space station. Assembly of the International Space Station (ISS) began in December 1998 and continues today. One hundred years after the Wrights' first successful powered flight, nearly 90 years after the formation of the NACA, and 44 years after the formation of NASA, international resident crews are living and working together in orbit. They are also conducting research in the physical and life sciences to help gain insight into what will be required to make the leap to long-duration space exploration missions with humans — the next step in the history of flight.

## Beyond Low Earth Orbit

Work to prepare for the next step in flight is taking place on many fronts at NASA. The Office of Biological and Physical Research (OBPR) supports projects that will help find requisite answers in order for humans to fly on missions beyond low Earth orbit and the Moon. What follows is a small sampling of the issues OBPR is addressing: how to design craft and equipment to get the maximum performance from crew with the least stress; how to keep astronauts healthy on the journey and sustain life on other planets, which includes research into fundamental biological processes as well as biomedical research; and how to encourage industry interest in space so space travel and research can become more commercially viable.

## Factoring in Humans

Anytime a crewmember interfaces with equipment or the environment during a space mission, human factors research comes into play. Researchers want to design equipment and craft so they are easy for the crew to use, making their performance of complex tasks more efficient and effective.

"The goal of human factors research is to maximize overall mission performance while reducing risk," says Thomas Rathjen, manager of the Habitability and Human Factors Office and of the Space Human Factors Engineering Project at Johnson Space Center in Houston, Texas. While behavioral and physiological issues associated with crew performance in space are the concerns of psychological and biomedical researchers, the human factors researchers concentrate on more concrete problems. "We pretty much are focused on those things that are exterior to the crewperson — the *things* that the person interfaces with," says Rathjen.

The field of human factors blossomed in World War II, when weapons systems, planes, and other equipment became much more complex than in the past. Industry realized that the human interface with machinery was an issue and so began to design systems with the human as a key component. The principle was simple; for example, rather than build a plane and find out after the fact that the design was not practical for pilots, industry developed flight simulators to test for ease of use before the planes were built.

"In the early days of NASA," says Rathjen, "a lot of the human factors work was done with crew participation — the *Gemini* and *Apollo* crews were directly involved with design issues of their craft. But the ISS is the first NASA flight program that has treated human factors as a subsystem with its own set of documented requirements." Because the ISS is a complex environment with a multinational and multicultural crew, nothing could be left to chance — in an emergency or other stressful situation,

crewmembers can't stop to figure out how to work something, nor can they be slowed down by the design of their living and working quarters.

"A simple example is a light switch," says Rathjen. "In the United States, up is on, and down is off. But that's not always the case in other countries. So one human factors issue is how to design labels, such as 'on' and 'off,' that can be easily and quickly understood by anyone."

Of course, astronauts could be told during training how certain systems or items of equipment operate, but expecting crewmembers to remember everything they were told in training once aboard the space station just isn't practical. Says Rathjen, "Imagine in an emergency situation, such as [the fire that] happened on *Mir*. You don't want crewmembers fumbling around trying to figure out how to find and operate emergency equipment. You need easy-to-understand symbols and colors that are universally understood and can help crewmembers to do more quickly and easily what they need to do."

Planning how to handle large crews working and living on spacecraft also falls under the heading of human factors. Although the permanent ISS crew of three isn't likely to expand in the near future, interior space is an issue when space shuttle crews are visiting the station. "We consider these times to be like 'camp-out' situations," says Rathjen, "and we look at them for ways to increase the productivity of everyone during those visits, given the limited space on station." Finding out how best to accommodate crew in a limited area will also help in planning a long-term mission or stay on another planet. "Every human factors issue that is important on the ISS will be even *more* important on an extended mission [beyond low Earth orbit]," says Rathjen.

Rathjen's group also performs design review and verification for hardware developers that send experiment equipment to the station, and it does lighting and viewing modeling. The latter involves predicting and simulating what crews will see in a particular situation. For example, the group can model the view a crewperson would have while manipulating a robotic arm, given such variables as the position of the Sun, the attitude of the station in relation to the Sun, shadows, reflections, and bright spots. Mission control uses these analyses to plan when crews will perform particular activities.

All these human factors issues and more are taken into account at the planning stage of equipment, habitation space, and special events like using the robot arm, but they aren't left there. According to Rathjen, station crewmembers have multiple means of suggesting design improvements. There is a habitability evaluation during each mission debriefing, and there is a "crew squawk" system whereby crewmembers can send complaints back to designers immediately.

Human missions to other planets will present new human factors issues beyond those relevant to the space



credit: NASA

station. One particular challenge for crews on a long mission or stay on Mars is that immediate communication with Earth will not be possible. Another is partial gravity, which on Mars is one-third that on Earth. This creates a new set of design issues. "You've got to design equipment that is suitable for partial gravity, and that's different than zero gravity," says Rathjen. "People's postures and biomechanics change when they are in a partial gravity environment, and that's something we have little experience with. Basically, the only experience we've had with partial gravity is our lunar landings." But despite the differences that may be encountered when humans travel beyond low Earth orbit, lessons learned now will provide valuable knowledge that teams like Rathjen's can use to enable top performance in the future from researchers and other crewmembers.

## Rays Banned

But even more basic than achieving top performance is protecting crewmembers from hazards that are part of the space environment, such as space radiation. Radiation involves high-energy particles (as well as X-rays and gamma rays) that can have deadly effects on living organisms. Space is heavily traveled by radiation that can sicken or kill any known life-form. While ISS crews are relatively shielded by Earth's magnetosphere, they are more exposed than people living at sea level beneath Earth's cushion of air. Crews that travel to Mars will be exposed to radiation for years rather than the days of exposure that *Apollo* crews experienced going to the Moon.

OBPR is working to define the problem in full even as it works on possible solutions. Its Strategic Program Plan for Space Radiation Research outlines a comprehensive approach to develop these solutions. In addition, NASA works closely with the National Research Council of the National Academy of Sciences and with the National Council on Radiation Protection and Measurements to maintain updated guidelines from the scientific and radiation protection communities.

Radiation protection is truly a cross-disciplinary, cross-division problem that touches life sciences, space

Human factors researchers must consider the amount of space that crewmembers require to be able perform their tasks efficiently. This model shows the clearances and required human operational envelopes around a patient restraint on the International Space Station.

*continued on page 24*



# Research Update: Bioastronautics Research

## In Sickness and in Health: Immunity and the Stressed Astronaut

*What is the reaction of the human immune system to the stresses of spaceflight? Two pioneering microbiology experiments on STS-107 may help our understanding.*

**W**ill astronauts bring with them the elements of disease that will cause them to fall ill during space travel?

Knowing the answer to that question is fundamental to planning a long-duration mission, such as one to Mars, as well as to understanding more fully the medical effects of prolonged stress on people on Earth. And a partial answer may come from two microbiology/immunology experiments under the direction of Duane L. Pierson, lead microbiologist for crew health and environmental safety at NASA Johnson Space Center in Houston, Texas. Both experiments are scheduled for the upcoming STS-107 space shuttle mission. More modest, narrowly focused immunology experiments have been conducted on astronauts on previous space shuttle flights, but STS-107 is the first mission during which a more comprehensive battery of tests will be run.

Historically, more than half the Apollo astronauts reported preflight and in-flight infectious illnesses. The incidence of infectious illnesses fell dramatically after Apollo 13, when the Crew Health Stabilization Program was instituted. The program restricts astronauts from contact with crowds, small children, and anyone showing symptoms of any illness for seven to 10 days before launch.

“Even with stringent precautions, however, space shuttle astronauts still report occasional skin cuts and abrasions and note that wounds take longer than usual to heal,” Pierson says. Moreover, there’s one class of infectious

agents against which no quarantine offers protection: latent viruses that — like the proverbial Trojan horse — lie dormant within an astronaut’s own body and can reactivate and replicate, perhaps attacking at an unguarded moment.

Evidence of any impairment of the immune system’s ability to fight infections in space and evidence of stress-related reactivation of latent viruses is what Pierson and his colleagues are seeking through their experiments flying on STS-107.

### Stress and the Immune System

“It’s well known that prolonged physiological or psychological stress can diminish the immune capability, resulting in increased risk of illness,” Pierson observes. Stress compromises the immune system by acting primarily on three glands: the hypothalamus, the pituitary, and the pair of adrenals. “When the

hypothalamus in the brain perceives danger or some other stress requiring the body to be put on high alert, it communicates ‘we’ve got a problem’ to the pituitary gland, which regulates the adrenal glands,” he explains. “The central nervous system then communicates to the adrenals either through the sympathetic nervous system — the ‘hard wiring’ of nerves — or through the pituitary by the release of soluble chemical messengers into the blood.” Finally, the adrenals release several stress hormones — adrenaline (epinephrine), noradrenaline (norepinephrine), and cortisol (a form of cortisone) being the most familiar — to the entire body, increasing the force of the heart-beat and giving the muscles unusual strength in the classic “fight or flight” response.

In marshalling all the body’s resources to handle an immediate crisis, however, adrenaline and the other stress hormones “tend to slow down all non-urgent bodily functions, including the immune response,” Pierson notes. “Such diminished immunity is supposed to be a temporary thing until the immediate crisis passes. But problems arise if stress is prolonged. Under chronic stress, the immune system can be lowered enough that the body becomes more vulnerable than usual to bacterial or viral infections.”

What concerns Pierson and his colleagues at Johnson Space Center is that “space is a unique high-stress environment for astronauts.” First there is the transient physical stress of several g’s of acceleration to get off Earth. There is the psychosocial stress of dangers inherent in launch itself, confinement to a small living space for weeks or months, demands of long work hours or of conducting many

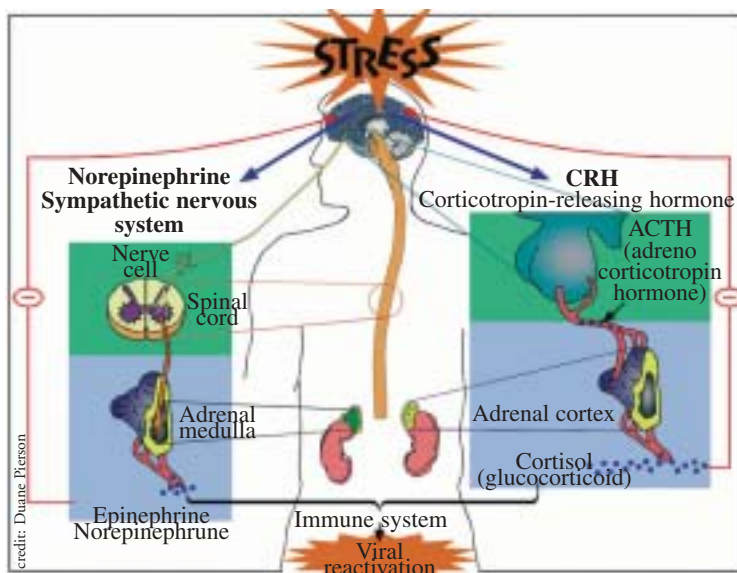

Stress compromises the immune system by acting on several glands to release stress hormones such as epinephrine (left) and cortisol (right) into the bloodstream. Remaining in a stressed state for extended periods can suppress the immune system enough to allow latent or new infections to be expressed.

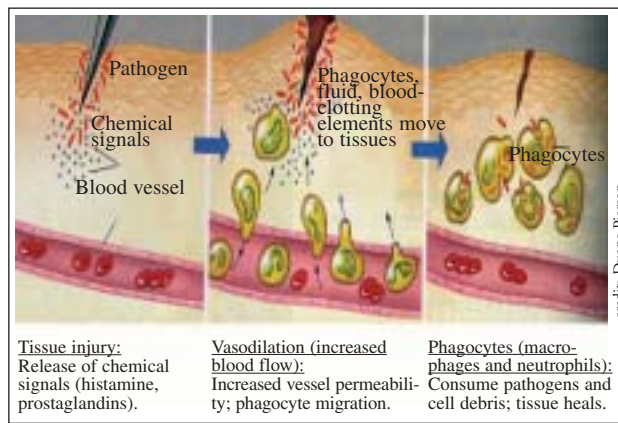

experiments and extravehicular activities, not to mention isolation from family, some sleep deprivation, and the shifting dimension of time. At a mission's end, there is the tension of plunging back into Earth's atmosphere in a superheated vehicle. And for the entire duration of being in orbit, there's one ever-present situation never experienced on the ground: microgravity. Significantly, prolonged physical and psychological stresses can diminish or alter the immune response even when people don't perceive them as negative — and clearly, astronauts relish the excitement of going into space.

Hence the big question: Can the unique stresses associated with spaceflight have a measurable medical effect on the human immune system? From the results of earthbound studies of people in high-stress professions (law enforcement, firefighting, and the like) as well as in high-stress environments (such as wintering over in Antarctica), Pierson strongly suspects that they can. Instead of relying on subjective questionnaires that ask the astronauts whether or not they *feel* stressed, Pierson and his colleagues want to obtain independent and objective physiological measurements of stress — such as, say, the levels of stress hormones in the blood. “Before sending people to Mars,” Pierson says, “we need to understand the human immune response to spaceflight.”

## Experiment #1: The Body's Defensive Army

Pierson's first STS-107 experiment, conducted on blood drawn from astronauts before and after flight, is designed to measure whether the stress of launch, spaceflight, and return to Earth has any effect on the ability of three types of white blood cells to fight infection.

To use a military analogy, the human immune system actually consists of two complementary divisions, the adaptive and the innate. The adaptive division creates antibodies to specific microbial invaders (either through previous infection or through vaccination), essentially causing the body to retain

a “memory” of a specific invader. In contrast, the innate division of the immune system is the body's first line of defense against all invaders indiscriminately — attacking and destroying *all* cells recognized as foreign. The soldiers of both divisions are specialized white blood cells.

It is the innate division of the immune system that interests Pierson and his colleagues. Specifically, Pierson wants to investigate the effects of spaceflight and return to Earth on three different types of white blood cells: neutrophils, monocytes, and natural killer (NK) cells.

Like a military force on a field of battle, each type of soldier has a different method of attack.

Neutrophils are short-lived, relatively small and agile white cells that function as the first wave of the cavalry. Moments after an injury or infection, they rush to the site as part of the inflammatory response and begin destroying foreign bacteria or yeasts by a process called phagocytosis. “A neutrophil sees a microbe and engulfs it, killing it through an oxidating burst with a super oxide or hydrogen peroxide,” Pierson explains. “Then internal granules in the neutrophil digest it,” at which point the neutrophil dies (pus in a wound is mostly dead neutrophils). Neutrophils are essential in healing ordinary cuts and scratches and repairing worn-out or damaged tissues.

Monocytes are long-lived, much larger and somewhat slower-moving white cells that function as the heavy artillery. Once they reach the site of infection, they migrate out of the bloodstream into tissues, where they become potent macrophages — assisting the neutrophils in their job of

When an injury or infection occurs (left), chemical signals, such as prostaglandins, are released to alert the immune system to the problem. In response, the blood vessels near the infection site dilate and become more permeable to allow the white blood cells to migrate from the blood into the surrounding tissue (center). Once the neutrophils and monocytes encounter the foreign bodies, they engulf and destroy them (right).

phagocytosis. “Macrophages do the heavy lifting,” Pierson says, engulfing foreign bacteria and yeasts “and even particles of dirt,” and breaking them apart. But instead of just digesting the smaller pieces, macrophages present the smaller pieces to other types of white cells (notably T cells); antibodies are produced by plasma cells, thereby interacting with the adaptive division of the immune system. Monocytes and macrophages are particularly important in healing deep puncture wounds.

NK cells are special-purpose scouts and mercenaries. There are relatively few of them in the bloodstream compared with neutrophils and monocytes. “They are always on surveillance, not only for bacteria but also for cancerous tumor cells and cells infected with viruses. And when they see 'em, they zap 'em,” says Pierson.

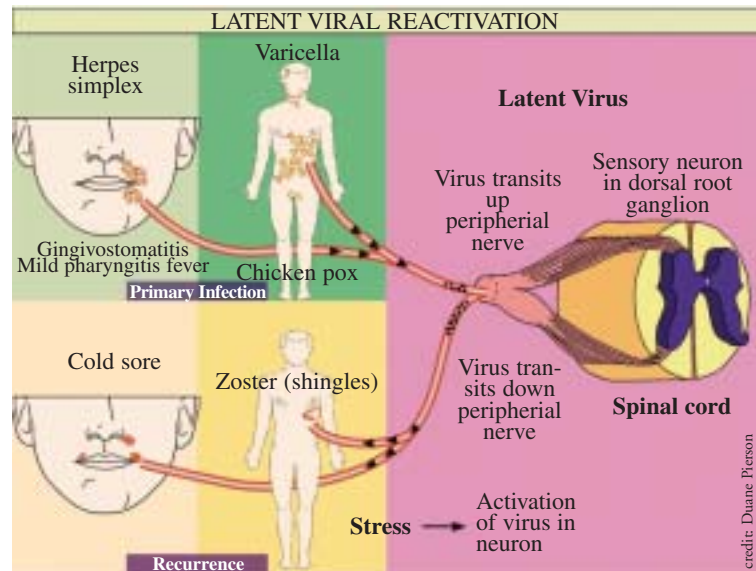

Some viruses, such as the human herpesviruses, can remain dormant in the body for years after the initial, or primary, infection. Although the immune system responds to primary infection by these viruses, some portion of the virus is able to “escape,” traveling up peripheral nerves and lying dormant in ganglions near the spinal cord. Prolonged stress, which compromises the immune system, can allow the virus to come out of “hiding” and travel back down the peripheral nerve to cause a recurrent infection.

The question that intrigues Pierson and his colleagues is this: Could the persistent stress of spaceflight suppress the innate arm of an astronaut's immune system enough that

*continued on page 25*

# Research Update: Fundamental Space Biology

## Fishing for Clues: A Common Tropical Fish Makes Its Contribution to Science

*One small black-and-white fish is making huge contributions to developmental neurobiology. Researchers like Stephen Moorman are using zebrafish to understand critical periods of development that are common to all vertebrate species.*

**I**n the early 1980s, Hungarian-born researcher George Streisinger published his method for using zebrafish, a common tropical fish, to study nervous system development among vertebrates. His idea was inspired: zebrafish are small and relatively easy to maintain. They are available at pet stores at the nominal cost of 50 cents each if you buy 200 at a time. The female zebrafish lays 50–100 eggs each day at a very predictable time, and from the time of fertilization, the eggs take about three days to hatch. At a little more than a millimeter in diameter, the eggs, which have a transparent shell, can be seen without a microscope, and with a microscope, the embryo is very easy to see. Using a microscope, researchers can do things like watch neurons in the nervous system as they develop — an intriguing possibility for developmental neurobiologists such as Stephen Moorman, of Robert Wood Johnson Medical School in Piscataway, New Jersey.

### Calling All Vertebrates

About eight years ago, Moorman became intrigued by the possibilities for research that zebrafish suggested. The

connection between studying developmental biology in fish and the development of the complex neurological system of humans might not seem obvious unless you know that there is an incredible amount of similarity between genes across all vertebrate species and that researchers can perform studies using zebrafish that are far less expensive than studies using laboratory mice.

After completing his postdoctoral work, Moorman took a faculty position at the University of Texas Health Science Center, where a colleague was pursuing NASA-funded research on the effects of microgravity on cells. Through this colleague, Moorman learned about a NASA-designed bioreactor and its ability to simulate microgravity conditions in ground-based laboratories. He examined the fluid-filled bioreactor and realized that zebrafish eggs (which are just big cells in culture) could be studied in the machine to determine whether simulated microgravity had an effect on the development of the zebrafish's vestibular system.

Moorman's leap of logic was based on the work of neurobiologists David Hubel and Torsten Wiesel in the 1960s on the development of sight. Hubel and Wiesel found that keeping newborn animals in the dark for a certain period during development resulted in blindness, not because their eyes did not function but rather because the brain, without a proper context, could not interpret the signals it received from the eyes. Explains Moorman, "We know that the context has to do with how the eye is wired to the brain. That wiring pattern depends on the eye being exposed to light during a critical period."

The critical period Moorman describes has two key components: It is the period in development during which,

if the stimulus is not present, the correct "wiring" does not take place and never will, and it is the smallest amount of time that the stimulus must be present to result in proper wiring. "It turns out that the same thing is true for the auditory system, but with sound, as well as for taste, smell, and touch," Moorman says.

Using these principles of developmental biology, Moorman hypothesized that if he put zebrafish eggs in the bioreactor, their vestibular system — a sensory system whose stimulus is gravity — would not wire correctly. The vestibular system, located in the inner ear, consists of three tubes, the semicircular canals, that are oriented at right angles to one another. Using these tubes, the brain monitors the orientation of the head while it is moving. The vestibular system also has two or three swollen spots that have hair cells lining the inside. Small crystals, or stones, of calcium carbonate (otoliths) lie on top of the hair cells. When you tilt your head, the crystals try to slide across the hairs and cause them to bend. The bending sends a signal to the brain, telling it which way the head is tilted. In zebrafish embryos and hatchlings, the vestibular system is located just behind the eye and is half the size of the eye. "Under a microscope," says Moorman, "it's a really easy part of the animal to see."

The vestibular system, in conjunction with other parts of the nervous system, is responsible for humans' ability to maintain balance. Although humans are capable of using other stimuli — such as light and even the digestive system — to orient themselves, the vestibular system is the major source of information about orientation.

People with improperly functioning vestibular systems feel dizzy as they go



credit: Stephen Moorman

Zebrafish, a common tropical fish, is a widely studied model for developmental biology. Zebrafish offer researchers an inexpensive way to study developing systems and organs that are common among vertebrate species.

Stephen Moorman, in his laboratory, holding the bioreactor that allows the study of zebrafish in the absence of a net force (gravity). The bioreactor enabled Moorman to test his theory that the vestibular system of zebrafish would be affected by exposure to microgravity during the critical period of “wiring” of the sensory system to the central nervous system.

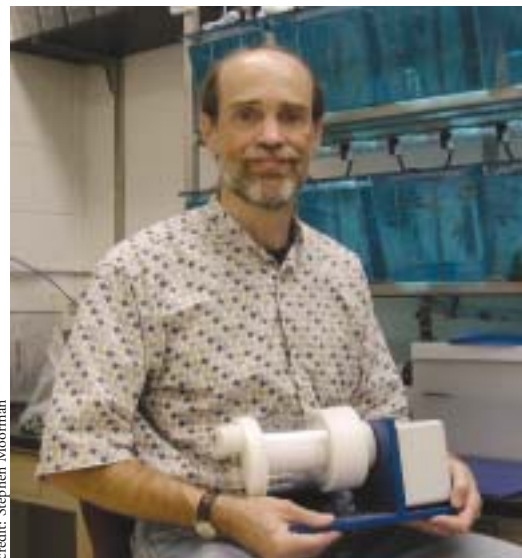

credit: Stephen Moorman

about their everyday activities. Problems with the system can be the result of injury to the inner ear or of viruses that affect neurons in the inner ear. “The idea behind this research has always been that there’s a lot that we could learn from basic science experiments on developing animals that may help us to design treatments to help cure diseases,” explains Moorman. “If you have a disease or an injury that destroys part of the inner ear, and you want to recover from that, you may want to jump-start or restart some of the developmental mechanisms.”

Improving our basic understanding of the development of the vestibular system will also affect future plans for exploration and long-term habitation in space. Exposure to microgravity during critical periods of development could mean that the vestibular system never “wires” properly to the central nervous system.

Moorman’s search for literature on vestibular development in microgravity revealed that much work remained to be done to determine conclusively the role that gravity plays. Many previous experiments conducted on the space shuttle had produced what Moorman calls “tantalizing” clues. “There’s a lot of interesting evidence that suggests that what we see in the visual system, what we see in the auditory system, might be true for the vestibular system,” he says, “but the question hasn’t been answered completely.”

“If you don’t fly the animal at the right developmental stage, you don’t see the effect,” he explains. “If you don’t fly

the animal for the right duration, you might not see the effect.” That’s why finding a way to refine the experiments in ground-based laboratories was so important.

## The Right Crew for the Job

Moorman started with two tanks of zebrafish, a donated bioreactor, and student assistants from local high schools. “Six months later, we had answers,” he says.

The first step was to look at how the zebrafish hatchlings swim after exposure, as embryos, to simulated microgravity during the three-day incubation period. Because the vestibular system helps the animal to orient correctly while it’s moving, observing swimming just after the hatchlings emerge from the bioreactor could tell the research team a lot.

The hatchlings were placed in a beaker of water, where they tended to lie on the bottom until prodded to swim. “When you poke them, a normal little hatchling will swim straight across the dish and either hit the edge and stop or turn and swim around the edge of the dish and stop. But these guys, when you poke them, they swim corkscrews, loops, they swim just like the classic descriptions of fish swimming in microgravity,” notes Moorman. But simply observing that the fish were swimming oddly is a qualitative observation; Moorman needed quantitative results.

## The Eyes Have It

Moorman and his team looked to the

eyes of the fish to quantify their results. “Your visual system would get very interesting input unless your eyes knew that your head was moving,” says Moorman. “That’s the role of the inner ear — it tells the eyes that the head is moving. In return, the eyes move in response to head movement. For zebrafish, their eyes will rotate just like ours do, but the comparable movement [to humans tilting their heads from side to side] is to tilt the fish tail up and down.”

The researchers put individual hatchlings in glass tubes, then placed the tubes under a microscope and observed the zebrafish’s eyes as the tube was tilted. Moorman says, “If you put the fish into the bioreactor for three or four days, that eye rotation didn’t work right. We documented exactly how much we tilted the fish and exactly how much the eye rotated in response to that movement. The graph looked distinctly different from that for our control animals.”

Moorman and his team identified the critical period for functional development in zebrafish: between 24 and 72 hours after fertilization. “If you put them in the bioreactor during just that period, they will have vestibular deficits,” Moorman says. “If you put them in the bioreactor for any time other than that critical period, or even just a portion of that period, they are relatively normal, or

*continued on page 26*

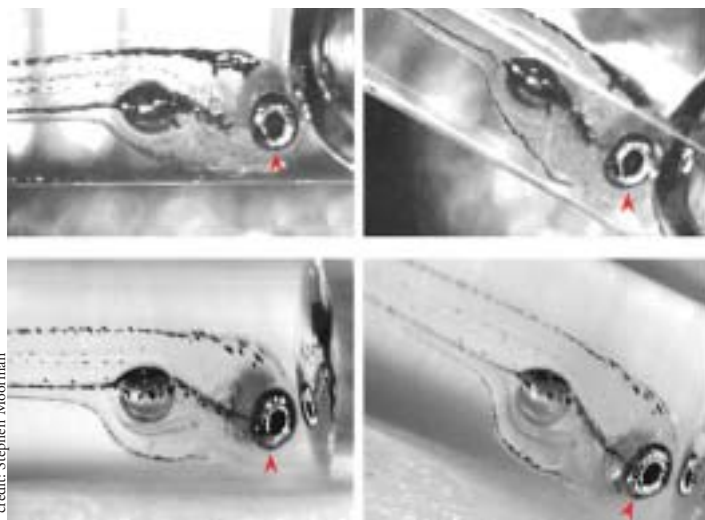

credit: Stephen Moorman

A head-tilt test is performed on a zebrafish hatchling to check for vestibular deficits. The black line (indicated by the arrowhead in each picture) visible in the eye of the fish is the point at which the iris will eventually fuse together to form the pupil. At this stage in development, fusion is not yet complete, offering researchers a convenient reference point for measuring the rotation of the eye. In a fish with normal vestibular function (top row), the eyes rotate in response to the up and down movement of the tail in order to maintain a stable visual image. Note that the reference point stays at the bottom of the eye, indicating that the eye rotated. In a fish with vestibular deficits (bottom row), the eye does not rotate properly but instead maintains a consistent orientation with respect to the fish’s body.



# Research Update: Physical Sciences

## Shake, Rattle, and Roll: Figuring Out Granular Flows

Watching how beads collide in space may help quantify how grains of wheat, plastic pellets, pharmaceutical capsules, and avalanches all flow on Earth.

**W**hat do prescription pills being funneled into a bottle, sand dunes migrating across a desert, breakfast cereal pouring into a bowl, snow avalanching down a mountainside, and coal cascading down a chute have in common?

They're all composed of moving chunks of material, large and small. They're all subject to gravity. Their behaviors are all important to understand for reasons ranging from safety to health to commercial profit. And those behaviors are all the province of a field of physics known as granular flow.

"Granular flows are essential to many industrial processes on Earth," explains James T. Jenkins, professor of theoretical and applied mechanics at Cornell University, Ithaca, New York. "In the production of plastic toys, for example, the raw material is handled as pellets until it's melted and formed into the final product. In a coal-fired power station, fully 60 percent of the cost is sunk in transporting coal in a freight train, onto a conveyor belt, or into a boiler. And for predicting natural phenomena such as avalanches of rock or snow, you must understand granular flow."

### It's a Solid! It's a Liquid! It's...Both!

Problem is, granular flow is so complex it's poorly understood.

Physicists have long had neat mathematical equations that fully describe the behavior of bulk solids like bricks, liquids like water, and gases like air. But granular materials "sometimes act like solids and sometimes like fluids," Jenkins points out, "and the transition from one behavior to the other is *very* rapid." For

example, gravel in the back of a dump truck sits virtually unmoving in a solid pile, even as the truck bed begins to tilt — until a certain angle is reached, and then suddenly it all tumbles downward in a thundering river of rock.

While industries have studied the behavior of specific types of granular materials so as to design efficient materials-handling systems for individual applications, no one has yet devised a mathematically precise description of granular flows in general. That's now Jenkins's aim: "I'm a theoretician, trying to come up with continuum equations for grain flows," that is, equations for when moving grains of solid materials behave like fluids.

Why is that such a desideratum?

Fluids can be completely described by partial differential equations — essentially, mathematical averages of the behaviors of the millions of molecules that make up the flowing liquid. Partial differential equations not only accurately predict how liquids flow depending on such numerical characteristics as viscosity, pressure, and temperature; they are also so computationally efficient that they are easy for desktop computers to solve. Thus, they are highly practical for helping to, say, design injection-molding systems.

Granular flows, however, so far have resisted adequate description by partial differential equations. Averaging the velocities of discrete particles loses essential detail about differences in velocities of individual grains — velocity fluctuations that near boundaries tend to segregate particles by size and/or mass. For example, seemingly in blithe disregard of the laws of entropy that claim the

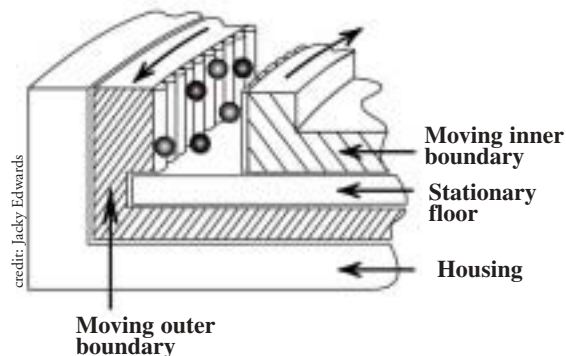

Schematic detail of a small segment of the shearing cell chamber shows its rectangular cross section and counter-rotating corrugated boundaries. Not shown is the stationary clear window on top (parallel with the stationary floor) through which a camera photographs beads in the chamber.

universe is growing ever more disordered, crumbs simply insist on filtering to the bottom of a cereal box (dust at the very bottom of all), while larger flakes and dried fruits congregate near the top. "Typically you want particles to stay mixed," Jenkins explains, "so you need to understand the mechanisms of spontaneous de-mixing." Other times, spontaneous segregation in granular flows causes clumping that can quickly halt an entire flow — a perpetual nuisance in industrial applications wherever a granular flow must be funneled down from a large river to a thin stream. Thus, in any continuum equations for granular flows, segregation and clumping are essential to understand and to model mathematically.

So far, the only successful simulations of granular flows have relied on treating each individual grain as a discrete particle — each having a certain mass, subject to Newton's laws of motion, the force of gravity, frequency and amplitude of agitation, and coefficients of friction and "restitution" (the elasticity of collisions between particles at different angles). But such brute-force simulations are so computationally demanding that even a supercomputer can't simulate the behavior of many more than 10,000 particles — not very representative of the millions or even billions of grains flowing in real-life corn elevators or landslides.



## Getting Rid of Gravity

On Earth, segregation in every granular flow is influenced by at least two distinct types of interactions: gravitational and collisional. (For very small grains and powders, electrostatic interactions also become important; but, for simplicity, Jenkins is concentrating on large grains.) On Earth, though, gravity so dominates the physics of granular flows that it's virtually impossible to isolate and quantify the contribution of collisional interactions.

Hence Jenkins's desire to study how BB-sized multicolored beads of ceramic, steel, and acrylic collide with one another when "weightless" in space. "We have to get Earth's gravity out of the picture," he declares, "to create a simpler system where segregation in granular flows is dominated by collisions."

Jenkins's experimental apparatus is conceptually simple. The heart of it is a shearing cell: a doughnut-shaped chamber that is really a gap between two concentric counter-rotating cylinders within a close-fitting stationary housing [see figure]. The outer wall of the inner cylinder and the inner wall of the outer cylinder are separated by about an inch, equivalent to about 10 diameters of the beads used in the experiment. The walls are also

machined with parallel, hemispherical corrugations 2 to 4 mm across — roughly the size of the beads used in the experiment.

When an experiment begins, the chamber between the two cylinders is partially filled (anywhere from 15 to 40 percent full) with two different species of beads — either ones of different sizes but the same mass, or ones of different masses but the same size. Then the inner and outer walls of the chamber are set to rotate in opposite directions up to 90 revolutions per minute. The speed-bump-like corrugations knock against beads nearest the walls, causing them to collide with ones closer to the center of the chamber, transferring both momentum and a shearing force across the width of the chamber. Through a transparent window that forms the stationary housing's top wall, a high-speed camera photographs the colliding beads at 1,000 frames per second for the duration of each experimental run — ideally several minutes, depending on the specific experiment.

Then begins the tough slogging. Special software developed by Jenkins's Cornell colleagues analyzes each photographic frame, mapping the tiny displacement of each individual bead from one frame to the next and diligently tracking how beads tend to segregate themselves by type toward the inner or outer wall. From these quantitative measurements of the motions of different types of beads at different wall speeds, Jenkins and his colleagues compare the observations with what is predicted by their theory.

Now, when the chamber runs on the ground, two forces act on the beads: the horizontal momentum transfer caused by the chamber's rotating walls and the vertical force of Earth's gravity (perpendicular to the toroidal chamber). In microgravity, however, the beads would freely float in the chamber during the experiment; thus, their segregation would be determined *only* by collisions among one another and with the chamber's inner and

## Sand Dunes on Earth and Mars

Cornell professor James T. Jenkins's mathematical work on granular flows could thrill agricultural planners and planetary geologists as well as industrial designers. For Jenkins (along with collaborators in Gainesville, Florida, and Rennes, France) is fascinated by three aspects of granular flows in natural sand dunes.

The first is saltation. "The word comes from the French *sauter*, meaning 'to jump,'" Jenkins explains. Saltation happens above the gently sloping windward sides of dunes when grains are suspended in mid-air by turbulent puffs of wind, fall and strike the sand again, and then rebound and eject other grains — which can then do the same. "Under the right wind conditions, saltation can become a self-sustaining system of jumping sand grains moving along a dune."

The second is sheet flows, an extension of saltation when the wind becomes strong enough that sand grains begin to collide with one another in mid-air. "In sheet flows, the mass transferred is extremely large," Jenkins says, in some sandstorms moving entire dunes impressive distances — up to kilometers.

The third is avalanches of sand down the steep lee side of a dune. Together with sheet flows, avalanches allow an entire dune to move in a sandstorm "a little like a tank tread," Jenkins said, with sand particles circulating from the top to the bottom of the dune.

Once again, Jenkins's goal is to characterize sheet flows and avalanches in terms of continuum partial differential equations that will model the movement of sand grains as if they were a fluid. "When described appropriately, equations will contain within them the way avalanches scale with viscosity, velocity of turbulent wind, grain diameter, and gravity," he says.

Not only could his work be relevant to nations where the relentless advance of desert dunes is a serious threat to habitation and agriculture, it could also be a boon to planetary geologists. "If we can fully describe dunes on Earth," Jenkins points out, "we should be able to do so in different atmospheric conditions on Mars as well."

outer walls. In other words, in space Jenkins would have just the "simpler system" he needs to understand the respective contributions of collisions and gravity, and to formulate equations to describe segregation and clumping.

So far, early prototypes of Jenkins's shearing cell have flown on NASA's

*continued on page 24*



A prototype of James T. Jenkins's shearing cell apparatus for investigating granular flows in microgravity, designed by Research Technician Stephen Keast at Cornell University, has been tested in NASA's KC-135 aircraft. The shearing cell itself is inside the large aluminum block at the left near the man's feet. The bank of electronics on the right controls the experiment's operation as well as the camera recording data. On the space station, a similar cell will run eight different experiments using three different species of beads (different sizes and masses).



# Research Update: Space Product Development

## From Child's Toy to ISS: Flywheels Hold the Power

*Flywheel energy storage systems are under development to provide a more efficient and cost-effective alternative to electrochemical batteries in spacecraft, as well as in cars and other everyday applications.*

**A**s dangerous as a power outage in a home, power plant, or a hospital can become, it's nothing compared to the crisis humans may face if they lose power on a spacecraft. Take the International Space Station (ISS), for instance. It relies on electricity for all its myriad functions. The ISS uses electricity to power its lights, run its life support systems, and energize its computers, as well as several expensive and scientifically important experiments. Electricity even splits water molecules to create the air the ISS astronauts breathe. Electrochemical batteries provide power for the station when it enters the Earth's shadow each orbit, but NASA is seeking an improved method of storing electricity on spacecraft.

Principal Investigator Alan Palazzolo of the Center for Space Power (CSP), a NASA commercial space center at Texas A&M University, College Station, Texas, has been working on various parts of a flywheel energy storage system, or kinetic battery, for many years. He and his colleagues are taking aspects of the current terrestrial technology and fine-tuning them for space applications. Their work has already yielded several patents for CSP and its research partners.

### Powering the ISS

Currently, the ISS is powered by several solar arrays, which contain multiple solar, or photovoltaic, cells. More arrays will be added as construction of the space station continues. These photovoltaic cells, which produce electric current from sunlight, are pointed toward the Sun to catch as much light as possible. While the station is in light, the cells power the craft directly and charge a bank of rechargeable nickel-hydrogen batteries that then provide power while the station is in shadow. Because it is in low Earth orbit, the station

can be in shadow for as long as 36 minutes of its 92-minute orbit. Thus, these batteries constantly discharge and recharge.

Unfortunately, electrochemical batteries, such as nickel-hydrogen rechargeables, can be discharged and recharged only a limited number of times. Replacing worn-out batteries by space shuttle is expensive — in cost of the actual batteries, in lost cargo space on the space shuttle, and in installation time.

A flywheel energy storage system would be more efficient, weigh less, and have a longer life than electrochemical batteries under the same conditions. Flywheel batteries could save NASA tens of millions of dollars a year in equipment and energy costs, as they could be used in satellites as well as the space station, and they would yield significant benefits for terrestrial applications as well.

### Energy Transfer: Potential to Kinetic

Batteries work on a simple premise: Energy can be neither created nor destroyed, just transferred from one type to another. In simplified physics, batteries transfer potential, or stored, energy into kinetic energy, or movement. An electrochemical battery stores potential energy through the chemical reaction of its components. The reaction creates free electrons that, when connected to a circuit, will move through the circuit and drive a load (a motor or lightbulb, for example). This reaction will continue until the chemical reactants are depleted.

For rechargeable electrochemical batteries such as those used on the ISS, reversing the current through the circuit reverses the chemical reaction. Electrons are returned to a higher energy state by rebuilding the chemical composition.



credit: Texas A&M University

Alan Palazzolo and his team at the Center for Space Power in College Station, Texas, have been working to increase the reliability of the magnetic suspension of the flywheel energy storage system for use in spacecraft. This high-speed test rig is used for developing a monitoring and diagnostic system to detect and correct anomalous conditions and to adaptively optimize the flywheel magnetic suspension for improved flywheel efficiency.

This restores the chemical reactants to their original composition and transfers energy (from sunlight, in the case of the ISS) to potential energy once again.

Flywheel batteries also work by transferring energy. First, kinetic energy spins up a flywheel. What's a flywheel? Think of a child's toy top, advises Fred Best, director of the Center for Space Power. "If you imagine a child's toy top spinning, that's fundamentally what a flywheel is, only a flywheel spins at much higher rates of speed and is much more massive than a child's toy. And the reason that the flywheel is useful is that the spinning aspect — that high rotational speed — is a way to store energy." In a flywheel battery, external electrical energy (through a motor) is the kinetic energy that powers the motor that spins up the flywheel, transferring the electrical energy to rotational kinetic energy. As the flywheel is discharged and spun down, the stored rotational energy is transferred back into electrical energy by the motor — now

reversed to work as a generator — and creates electricity to supply power where it is needed.

While flywheel systems do the same job as rechargeable electrochemical batteries, new developments have made them vastly superior in several ways. Best explains, “Recent advances — and by recent I mean over the past 10 years — in both the materials that you can make flywheels out of and the way to control flywheels, have allowed us to start spinning the flywheels up to very much higher energies than was possible in the past. What this means is that the energy we talk about being stored in the flywheel — its kinetic energy — begins to surpass, on a mass basis, the energy stored in an electrochemical battery.”

Researchers are finding that they can store much more energy per unit mass in a flywheel system than in electrochemical batteries. They have also determined that flywheels can be discharged at a higher percentage, meaning that more of the stored energy is available. As much as 80 percent more energy can be recovered from flywheels than from electrochemical batteries, given the same conditions. This increase in what is called depth of discharge offers several advantages. The flywheel systems could weigh less than electrochemical batteries, a benefit on spacecraft, where weight is a limiting factor. They could also survive more cycles of charging and discharging, with less wear and tear on the system and a longer life span. An electrochemical battery lasts between four and five years on the ISS, whereas a flywheel would last as long as 15 to 20 years.

While flywheel technology is now in use in several terrestrial applications — such as providing backup power for hospitals and serving as a power bridge (filling the gap between power outage and generator startup) in manufacturing plants — it is still a young technology. NASA is trying to capture some of the potential of this promising energy storage system by sponsoring innovative research, and the payoff may not be for the space program alone.

## Fine-Tuning for Space

Flywheel research at NASA is based at the Aerospace Flywheel Technology program at Glenn Research Center in

Cleveland, Ohio. Project Manager Ray Beach heads the program and is responsible for coordinating research from many different NASA projects, with the eventual goal of building a demonstration unit. This unit, which may be ready within the next five years, will be used to determine whether flywheels are a viable replacement for the electrochemical batteries on the ISS. Like the batteries, the flywheel system will be charged by current from the photovoltaic cells of the solar arrays. The current will spin up the flywheel through a motor, which will then be turned into a generator, and the flywheel will be spun down to transfer the energy back to the generator to create electricity.

Palazzolo and his researchers at CSP are among the main contributors to the work being done at Glenn. When Palazzolo started this research, the technology was not capable of the high speeds and split-second controls necessary for use in space. His solution was to develop better magnetic bearings. Best explains, “When you’re trying to rotate something at 60,000 rpm, if you had mechanically contacting bearings, the friction from that would be prohibitive in terms of the energy that would be consumed. Things would just melt. Palazzolo’s magnetic bearings suspend the rotor in a vacuum, and that’s what actually allows us to have these things spinning at 60,000 rpm.” This top rotational speed of 60,000 rpm is faster than any other flywheel system, and it can hold between three and four times more energy per unit weight than any other flywheel system that has been measured.

An additional challenge has been controlling the rotating shaft of the flywheel. Palazzolo is working on a feedback system that monitors the rotor and can make minute and rapid corrections to keep it true. Palazzolo describes how it works: “If [the shaft] deviates from the target [optimal location], then the feedback control takes that error, sends a correctional signal to the electromagnetic bearings that support the shaft, and the electromagnets then pull the shaft back toward the target.

“In a system like a flywheel, that’s spinning at a thousand revolutions per second,” Palazzolo adds, “the response time of the control system has got to be on the order of fractions of one millisecond.”

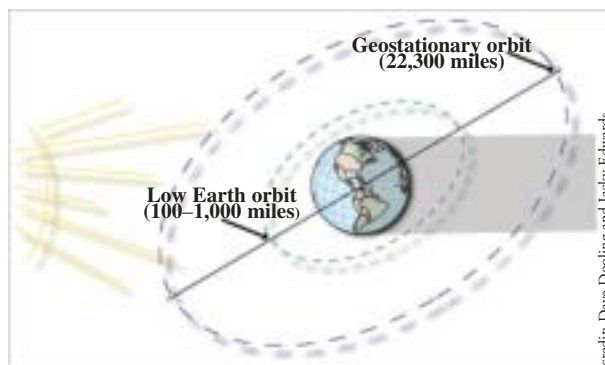

credit: Dave Dooling and Jacky Edwards

The efficiency of flywheel batteries may make placing satellites in low Earth orbit economically feasible. Currently, most satellites are in geostationary orbit, where they spend less time in shadow and so extend the life of their electrochemical batteries. Flywheel batteries would enable satellites to fly closer to Earth, where they could be used for communications without lag time.

Any deviation of the flywheel for more than a split second could have potentially damaging results, especially at full speed. In addition to shifting the flywheel back into balance, the control system can shut it down to prevent damage to the spacecraft. Development of these controllers resulted in a patent for Palazzolo and other researchers at Texas A&M University.

Another aspect of Palazzolo’s research for Glenn is the potential dual use of the flywheel as a battery and as a momentum wheel to assist with attitude control. “Because flywheels rotate, they can affect the spacecraft that they’re on,” says Best. “The Hubble Space Telescope has momentum wheels on it, and they act to allow the telescope to orient itself in space, to point in a given direction.” Without momentum wheels, spacecraft would have to use thrusters to “steer” themselves. Palazzolo is working on the possibility of creating a unit with both energy storage and attitude control capabilities.

## Commercial Applications

While much of Palazzolo’s work is with the Glenn project, the focus of CSP is leaning more toward the commercial application of their research. CSP is one of several commercial space centers within the Space Product Development Division of the Office of Biological and Physical Research at NASA. One way flywheels could be extremely beneficial to the commercial space industry is as an energy source for satellites, particularly communications satellites. Most satellites are geostationary, orbiting 22,300 miles above Earth and remaining fixed over

*continued on page 26*

# Education & Outreach

## DIME Pays Off for Youth

*Students who want to run experiments in microgravity earn profitable knowledge from NASA's DIME program.*

**C**oins are flat, durable bits of metal that clink in people's pockets, kerplunk into vending machines, and drop into cash registers. Whether it's a nickel, a dime, or a quarter, a coin can only fulfill its destiny as a fraction of a dollar. It cannot deliver more than its face value — unless, of course, we're talking about a NASA DIME.

This research opportunity worth more than its 10-cent name is offered by the National Center for Microgravity Research (NCMR) and NASA's Glenn Research Center (GRC) in Cleveland, Ohio. Dropping in a Microgravity Environment (DIME) is a competition inviting high school-aged teens to propose and conduct a microgravity experiment using GRC's 80-foot, 2.2-Second Drop Tower.

Since the drop tower's inauguration in the early 1960s, hundreds of physical science principal investigators and their students have taken advantage of the 2.2 seconds of microgravity it provides. In the short time it takes an experiment to drop from the top of the tower to the ground, investigators can collect important scientific data without gravity's influence on many kinds of phenomena. And

because it is less expensive than launching experiments into space, researchers have used the drop tower to test how an experiment will perform in a short-term microgravity environment before sending it into orbit for a longer run.

The DIME competition mimics the process NASA investigators must go through to test their hypotheses in the tower. The challenge to high school students incorporates cooperation, creativity, engineering, language arts, and research skills, just as it does for scientists. And that is exactly how DIME's creators intended it to be.

"DIME participants parallel what NASA, university, and industrial researchers do in terms of coming up with an experiment concept and writing a proposal, including what they'd like to get out of their investigation," says Richard DeLombard, DIME co-creator. "Then, if selected, the students continue the parallel by designing and building the experiment, operating it, analyzing the data, and writing a final report."

Three years ago, GRC researchers DeLombard and Dennis Stocker launched DIME to give teenagers a chance to learn about the effects of microgravity on Earth, as well as get their feet wet in scientific research. They were inspired by the reactions of students to both demonstrations of a small-scale drop tower (that provides 0.5 seconds of freefall) at science fairs and local middle schools and to the drop facility itself when they hosted onsite tours.

"Watching the students tour the facility got me to thinking — students should be able to think up some ideas to do an experiment" says DeLombard. "And it was most appropriate for high school-aged kids to be doing that."

DeLombard and Stocker, who are microgravity researchers themselves, have hosted a number of education and outreach events. DeLombard's research

focus is acceleration measurement, and Stocker's is combustion science. Carol Hodanbosi, a classroom curriculum developer who works for NCMR, is the lead DIME coordinator.

## Getting the DIME Rolling

While real NASA investigators may need years to develop and complete an experiment, DIME activity is scheduled within one school year. The competition is announced to students in early September, proposals are due in November, the DIME staff selects the winning teams in December, and the drops are usually performed in late April.

Students begin their search for an experiment concept by pondering how gravity affects the physics of various processes and phenomena. DIME competitors should propose experiments related to the physical sciences — combustion, fluid behavior, and fundamental physics are all possible topics. (Experiments on animals or insects are prohibited because the 2.2 seconds of freefall and sudden stop at the bottom are not amenable to biological processes.) Students form hypotheses as they try to guess what will happen when gravity-related phenomena such as buoyancy-driven convection and sedimentation are nearly eliminated in the drop tower. In addition to coming up with a microgravity experiment, each team should have a control experiment, one that is performed in normal gravity conditions for comparison purposes. To help generate ideas, the DIME CD-ROM and web site offer an introduction to microgravity, possible research topics, and design information for experiments.

Successful DIME experiments have tackled research questions similar to those NASA investigates. Combustion experiments are the most popular subjects among scientists using the tower. Fluid



credit: Richard DeLombard

DIME participants from the COSI Academy and their NASA mentor examine their data to see how a microgravity environment affected the motion of soybeans in a carbonated fluid.

experiments are a distant second. Both topics are also popular with the DIME students' experiments. During the 2000–2001 school year, DIME's pilot year, one of the two selected student teams dropped an experiment that burned a sample of cotton T-shirt to investigate how clothing burns in a microgravity environment. The students thought of this experiment after reading about fire safety and realizing that astronauts wear cotton clothing in space. The other 2000–2001 team put soybeans in a carbonated beverage just before releasing the drop package, to study the sedimentation, nucleation of bubbles, buoyancy, and the interaction between the gas bubbles and the soybeans. In normal gravity conditions, the denser soybeans sink and bubbles nucleate on them, which can sometimes lift the beans back toward the surface. The up-and-down motion of the soybeans was observed before and after the microgravity conditions of the drop (the motion stops during freefall).

In the 2001–2002 school year, four DIME teams were selected. One completed a combustion experiment on paper similar to office stock, and three studied various effects of fluid forces — such as surface tension, capillary force, and magnetic fluids — in a low-gravity environment.

“The materials the students used aren't necessarily the same ones our investigators use,” says DeLombard, “but the same basic topics of microgravity research are involved, such as how nearly eliminating gravitational effects, such as sedimentation, may affect other processes.”

Student applicants develop an experiment concept, draft a hypothesis, and submit a detailed proposal in accordance with the rules and guidelines of the program. A panel of NASA and NCMR researchers reviews the proposals and selects up to four teams to build their proposed experiments.

NASA sends each selected team a 12-inch-square grid mounting plate for its experiment hardware. A schematic of the experiment rig (the apparatus that will house the team's experiment) is also provided to show how the student experiment is connected to the rig. The rig includes a video camera and data recorder for recording the experiment behavior. Sometime in March, while the teams are finishing the

The 2.2-Second Drop Tower has contributed to the evolution of space exploration and technology for more than 40 years by allowing researchers and students to see how an experiment behaves under microgravity conditions. Objects dropped in the tower experience 2.2 seconds of microgravity during freefall. Microgravity conditions occur when a dropped object falls toward Earth with an acceleration equal to that due to gravity alone, approximately  $9.8 \text{ m/s}^2$ .

construction of their experiments, each team prepares a safety document, which describes attributes such as electrical requirements. In early April, the team ships its experiment to NASA for review. A few weeks later the teams, which consist of four students and one adult, make an expense-paid trip to Cleveland, Ohio, to attend the three-day DIME Drop Days.

The event's tower activities are webcast by GRC Imaging Technology Center personnel so that the sponsoring schools and the students' parents can observe the teams' activities in real time at home. During the webcast, the students are interviewed — each team introduces its members, explains its experiment, and shares future career goals. The operations leading up to the drop, the actual drop, and the recovery of the experiment rig after the drop are webcast; however, the video from inside the experiment rig cannot be viewed online.

“Team members also get to talk with NASA researchers while they're here,” DeLombard says. “Each team has an assigned NASA mentor to give advice during their experiment development and to help with experiment operation at the drop tower.”

During past DIME Drop Days, the students participated in microgravity workshops, a GRC facility tour, and a scuba demonstration at their hotel pool. (DIME cannot always guarantee the availability of a scuba demonstration, which is a simulation of astronaut neutral buoyancy training for activities outside a spacecraft in orbit.) Underwater, each DIME team constructed a polyvinyl chloride-pipe

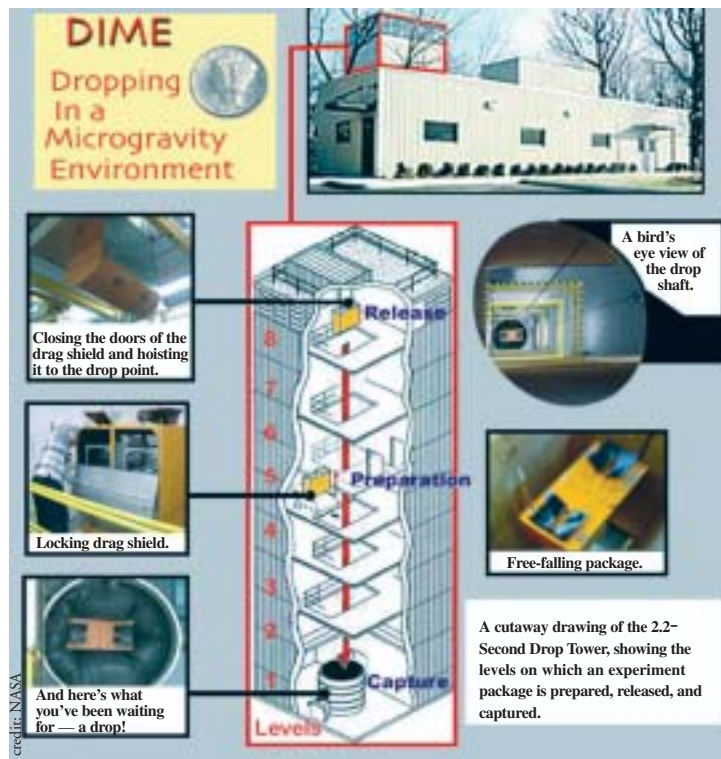

octagon that represented a space station hatch opening. Each team member then swam through the opening, trying not to knock it apart, to accomplish the goals set by the scuba instructors.

After the DIME Drop Days, the DIME teams must submit a final report to NASA by the end of May detailing the results of their experiment.

## DIME: The Missing Link

Dan Woodard, lead for NASA Physical Sciences Outreach and Education at NASA's Marshall Space Flight Center (Huntsville, Alabama), thinks the DIME competition fills a special niche in NASA outreach efforts. “DIME is the only student outreach program that involves drop towers,” says Woodard. “We have outreach programs that allow students to get involved in parabolic aircraft (KC-135) flights; in space shuttle launches through the Getaway Special canister (GAScan) programs, particularly out at Goddard Space Flight Center (Greenbelt, Maryland); and we have International Space Station opportunities for students to do experiments. But the drop tower was a missing link in NASA's student involvement.

“DIME is a relatively inexpensive way for students to experiment in low-gravity environments compared to other

*continued on page 24*

# Meetings, Etc.

## RESEARCH OPPORTUNITIES

[http://research.hq.nasa.gov/code\\_u/code\\_u.cfm](http://research.hq.nasa.gov/code_u/code_u.cfm)

### Research Opportunities in Physical Sciences

The Physical Sciences Division now issues only one NASA Research Announcement (NRA) a year, with information for proposing to each research program included. The discipline sections with selection dates in 2003 are as follows:

- **Biotechnology:** NRA-01-OBPR-08-B proposals were due September 3, 2002, and selections are expected to be made in March 2003. The NRA involves research to produce bioproducts that will enhance human health and welfare.

- **Combustion Science:** NRA-01-OBPR-08-C proposal selections were made in October 2002. Twenty-two researchers received grants totaling approximately \$8.6 million. Nine grants were to continue current research; 13 grants were for new research. The NRA solicited research into fire safety, pollution reduction, and combustion-related product development.

- **Fluid Physics:** NRA-01-OBPR-08-D proposals were due December 2, 2002, with selections expected to be made in June 2003. The NRA seeks research that explores fundamental physics and the dynamics of simple and complex fluids.

- **Special Focus Theme, Materials Science for Advanced Space Propulsion:** NRA-01-OBPR-08-G proposals were due September 3, 2002, with selections expected to be made in March 2003.

For more information on these announcements, see [http://research.hq.nasa.gov/code\\_u/nra/current/NRA-01-OBPR-08/index.html](http://research.hq.nasa.gov/code_u/nra/current/NRA-01-OBPR-08/index.html).

### Joint National Cancer Institute/NASA Solicitation

The National Cancer Institute and NASA solicited projects through a Broad Agency Agreement (N01-CO-27042-32) titled "Fundamental

Technologies for the Development of Biomolecular Sensors." The deadline for applications was November 1, 2002, and awards are expected to be made in the fall of 2003. For more information, see <http://rcb.cancer.gov/rcb-internet/appl/rfp/27042/toc.pdf>.

### Research Opportunity in Bioastronautics

The Bioastronautics Division solicited proposals for the ground-based study of space radiation biology and space radiation shielding materials. Responses to this announcement (NRA-02-OBPR-02) were due on November 25, 2002, and selections are expected to be made in March 2003. For more information, see [http://research.hq.nasa.gov/code\\_u/nra/current/NRA-02-OBPR-02/index.html](http://research.hq.nasa.gov/code_u/nra/current/NRA-02-OBPR-02/index.html).

## TECHNICAL MEETINGS

### 2003 American Association for the Advancement of Science Annual Meeting

Denver, Colorado

February 13–18, 2003

<http://www.aaas.org/meetings/Info.shtml>

This year's meeting of the American Association for the Advancement of Science will present a unique interdisciplinary offering of more than 130 symposia, plenary and topical lectures, seminars, poster presentations, career workshops and fair, and an exhibit hall. Lectures will be presented by some of the best researchers in the scientific, engineering, and technology communities. Topics of discussion include nanotechnology, communication, public health, genetics, global climate change, and education.

### 2003 NASA Cell Science Conference

Houston, Texas

February 20–22, 2003

<http://criticalpath.jsc.nasa.gov/iwg>

Hosted by the NASA Cellular Biotechnology Program at Johnson Space Center in Houston, Texas, in coordination with the Fundamental Space Biology Program at Ames Research Center in Moffet Field, California, this year's conference is geared toward encouraging coordination and collaboration among the various NASA programs that use cell systems in their research. Attention will be given to both flight and ground-based research. Activities include a dinner lecture, presentations, and exhibits. Presentation topics will include tissue engineering, neoplastic disease, cytoskeleton, and signal transduction activities.

### 2003 National Manufacturing Week

Chicago, Illinois

March 3–6, 2003

<http://www.asme.org/nmw/>

The only national forum of its kind, this year's National Manufacturing Week (NMW) will provide the unique opportunity for buyers and sellers of all sorts of manufacturing goods and services to gather under one roof. The conference program at NMW is coordinated by the American Society of Mechanical Engineers (ASME) International and will include more than 50 sessions with such topics as design engineering, manufacturing and industrial automation, and plant engineering and maintenance. OBPR will be presenting an exhibit at this event. Also sponsored by ASME International, NMW will include several short courses.

### 2003 Institute of Electrical and Electronics Engineers Aerospace Conference

Big Sky, Montana

March 8–15, 2003

<http://www.aeroconf.org/>

The Institute of Electrical and Electronics Engineers will present its 24th annual conference this spring. Attendees will include aerospace experts, academics, military personnel,

and industry leaders. The conference will promote interdisciplinary understanding of aerospace systems, their science, technology, and applications. Events will include poster sessions, a junior engineering and science conference, and plenary sessions on topics such as space missions, systems, and architecture; spacecraft avionics; remote sensing; and optics, electro-optics, and lasers. An additional session entitled "Space Station Science Experiments" will be presented.

### 65th Annual International Technology Education Association Conference

Nashville, Tennessee

March 13–15, 2003

<http://www.iteawww.org/D.html>

At their annual conference, International Technology Education Association members will share ideas for educating students of all ages. This will be an opportunity for educators to learn about the constant changes that take place in their field. Events for this conference will include general sessions, exhibits, interest sessions, a research poster session, and a silent auction. OBPR will be a part of the NASA-sponsored exhibit and will be distributing an education guide entitled *Science in a Box: NASA Glovebox Activities in Science, Math, and Technology*. An additional event is the technology festival, at which teachers can share their educational materials.

## EDUCATION

### 2003 National Convention — National Science Teachers Association

Philadelphia, Pennsylvania

March 27–30, 2003

[http://www.nsta.org/convention/details&Meeting\\_Code=2003PHI](http://www.nsta.org/convention/details&Meeting_Code=2003PHI)

Science teachers, administrators, scientists, and business and industry

representatives will gather to share information and discuss events and developments specific to science teaching over the past year. The National Association of Science Teachers is dedicated to promoting excellence and innovation in science education. Presentations and workshops at the conference are divided into six subjects: biology, chemistry, Earth, environment, physics, and general. NASA will give two presentations titled "A Different Kind of Launch: Online NASA Products for Our Classroom" and "NLIST: Networking for Leadership, Inquiry, and Systemic Thinking," and two workshops titled "Earth-to-Orbit Engineering Design Challenges" and "Amusement Park Physics." OBPR will be at the NASA exhibit and will be handing out educational products.

### National Congress on Aviation and Space Education

Cincinnati, Ohio

April 2–5, 2003

<http://www.capnhq.gov/conference/pages/nc/nationalcongress.html>

The National Congress on Aviation and Space Education is an event geared toward helping educators use aviation and space themes to encourage interest and academic excellence in their students. A main focus of the congress is how these themes relate to the national standards for education. Attendees will have the opportunity to explore the latest techniques and learning tools for hands-on classroom activities. Additional events include presentations by NASA astronauts and other aviation and space speakers.

### 81st Annual Meeting — National Council of Teachers of Mathematics

San Antonio, Texas

April 9–12, 2003

<http://www.nctm.org/meetings/sanantonio/index.htm>

Hosted by the Alamo District Council of Teachers of Mathematics,

this year's meeting of the National Council of Teachers of Mathematics has as its theme "Building Mathematical Communities." Events will include speaker presentations, an exhibit hall, workshops, minicourses, and poster presentations. OBPR and other NASA enterprises will sponsor an exhibit. Attendees will also have the option of attending a Research Pre-session April 7–9, 2003, which will enable them to examine issues of interest to the mathematics education research community in more depth and with more audience participation than normally possible with regular conference sessions.

## PROGRAM RESOURCES

### General Site

#### Office of Biological and Physical Research (OBPR)

<http://spaceresearch.nasa.gov>

- Latest biological and physical research news
- Research on the International Space Station
- Articles on research activities
- Space commercialization
- Educational resources

### Descriptions of Funded Research Projects

#### Science Program Projects

<http://research.hq.nasa.gov/taskbook.cfm>

**Commercial Projects** (also includes a description of the Commercial Space Center Program and other information)

<http://spd.nasa.gov>

#### Space Life Sciences Research Resources

(for literature searches)  
<http://spaceline.usuhs.mil/home/newsearch.html>



*The Wright Stuff continued from page 11*

biology, and the physical sciences. To systematically study the biological effects of space radiation, NASA has been developing a new ground-based space radiation simulation facility, the Booster Applications Facility. The facility, which is expected to be commissioned in 2003, is being built in collaboration with the Department of Energy and will utilize high-energy accelerators at Brookhaven National Laboratory in Upton, New York.

Ground-based studies in existing facilities have shown that the effects of space radiation are significantly different from the effects of X-rays and other radiation types common on Earth. The high-energy charged particles of cosmic radiation can easily break DNA molecules in more than one place. Space radiation has also been shown to enhance “genomic instability,” meaning that some of the dividing daughter cells, as many as 10 or 20 divisions later, will move toward becoming cancer cells at a rate much greater than control cells.

Because of these and other dangers, human space travelers avoid radiation in space by using “shielding” materials interposed between humans and the external radiation and careful timing of space activities to coincide with periods when radiation is least intense.

As fundamental biology research continues, eventually ways will be found to improve the ability of damaged cells to repair themselves, to help the body to rid itself of cells too damaged to be repaired, to understand the differences between individuals that make some less resistant to radiation than others, and to develop tools to diagnose changes, such as the ones that lead to cancer, much earlier, when the chances of successful treatment are vastly better. (See “Fire and Radiation Safety Get New Emphasis From Space Research,” *Space Research*, Vol. 1, No. 1, page 6.)

## Yesterday's Dreams, Tomorrow's Reality

Human performance and safety are not the only factors that will determine the success of human missions in space — the spaceflight industry will also play a significant role. Just as aviation had to be commercialized for its full potential to be realized, spaceflight may also eventually be dominated by private companies launching craft for use by industry, research organizations, and anyone else who wants access to space in order for people on Earth to reap its full benefit. In fact, NASA's charter calls for the

commercialization of space as a necessary and natural mission of the agency.

On a blustery day in 1903, the first powered heavier-than-air craft rose hesitantly and journeyed 120 feet. In 2003, space shuttle orbiters, each about equal in length to the entire distance of the Wright brothers' first flight and many orders of magnitude heavier than the wood and fabric creation flown at Kitty Hawk, soar into low Earth orbit and rendezvous with the International Space Station and its unique research laboratory. On a blustery day in 2103, overlooking the dunes of Kitty Hawk, what will the dreamers of tomorrow contemplate as our dreams become their reality?

Perhaps the answer for now is best left to the visionary scientist, poet, or writer. But whatever may be seen 100 years hence, the research of OBPR will have played a large role in creating that reality and future dream.

*Julie K. Poudrier*

For NASA's Centennial of Flight Calendar and numerous resources on the history of flight, go to <http://wright.nasa.gov> or <http://www.centennialofflight.gov> on the World Wide Web.

*Shake, Rattle, and Roll continued from page 17*

KC-135 aircraft, which soars up in a high parabola to yield about 20 seconds of microgravity in freefall.

Such brief periods are not enough to obtain scientific data useful for Jenkins's theoretical goals. (“It takes *minutes* of microgravity for the segregation of the beads to achieve a steady state,” Jenkins explains.) Also, unavoidable air turbulence and engine vibrations add unwanted mixing of the beads.

Nonetheless, the airborne tests have validated the basic experimental setup, tantalizing Jenkins with what the shearing cell might reveal in orbit.

The shearing cell is undergoing airborne flight tests and refinements of its design and data-collection software in anticipation of its scheduled launch to the International Space Station in 2007.

*Trudy E. Bell*

Jenkins's research team on the shearing cell includes Professors Michel Louge and Anthony Reeves at Cornell. Jenkins's collaborators on research on sand dunes include Professor Daniel Hanes at the University of Florida and Professor Daniel Bideau at the University of Rennes 1 in France. For an overview of Jenkins's work in granular flows, visit <http://www.tam.cornell.edu/Jim.html> on the World Wide Web.

*DIME Pays Off continued from page 21*

venues,” Woodard adds, “and it's a great way to excite students to do low-gravity research.”

And now that excitement is available to students nationwide. When DIME premiered, it was open only to Ohio-based schools. In the program's second year, teams from GRC's six-state outreach area (Illinois, Indiana, Michigan, Minnesota, Ohio, and Wisconsin) were eligible to

participate. This year (2002–2003) and in future years, DIME is open to teams in all 50 states, the District of Columbia, and Puerto Rico.

But students don't have to enter the DIME competition and travel to Cleveland to have fun with drop towers. Separate from the competition, DIME provides advice on how to build a miniature drop tower using inexpensive components and

video recording equipment, so students can conduct experiments in low gravity right in their own classrooms.

*Chris McLemore*

For more information about DIME, visit the program's web page at <http://microgravity.grc.nasa.gov/DIME.html> or contact Carol Hodanbosi, [DIME@grc.nasa.gov](mailto:DIME@grc.nasa.gov). To request an informative CD-ROM, send your name and mailing address to [DIME@grc.nasa.gov](mailto:DIME@grc.nasa.gov).



*In Sickness and in Health* continued from page 13

fewer monocytes and NK white blood cells would be produced — or that all the white cells would be somehow impaired in doing their jobs?

## Experiment #2: Latent Viruses

Pierson's other STS-107 experiment is designed to measure whether the stress of spaceflight can trigger the reactivation of latent viruses.

Latent viruses are ubiquitous. For example, virtually every adult carries one or more of eight currently recognized human herpesviruses, any one of which can infect its host for a lifetime. Herpesviruses include herpes simplex viruses types 1 and 2 (which cause fever blisters and genital herpes, respectively), Epstein-Barr virus (infectious mononucleosis and a number of cancers), varicella zoster (chicken pox and shingles), and cytomegalovirus (infectious mononucleosis, encephalitis, and other central nervous system diseases). Herpesviruses are also a leading infectious cause of blindness.

How do latent viruses differ from other infectious viruses, such as strains of influenza? "With respiratory flu, you feel bad for seven to 10 days while your body's adaptive immune system attacks and kills the virus," Pierson explains. "As the immune system drives the virus out of your body, you feel better. Eventually, the virus is completely gone," he continues.

But the immune system usually does not drive a herpesvirus out of your body completely. Instead, as the immune system gains the upper hand, the virus retreats up a nerve to a ganglion (mass of nerve tissue) near your spinal cord. "Symptoms clear up and you feel better, but the virus continues to reside [hide] in your body in a latent stage," Pierson says, "and no further symptoms occur — perhaps for years."

Inside your body, the virus lies in wait until it is reactivated by persistent stress, when it may start multiplying. Eventually the virus shows up in bodily fluids such as urine or saliva in a process called "shedding." When a

person becomes sick or stressed, the numbers of viruses in the body may rise to the point of producing symptoms (such as an outbreak of fever blisters), which completely differ from the symptoms of the initial infection. But viral shedding can also occur without any overt signs of infection. This *asymptomatic* shedding is of greatest interest to Pierson and his colleagues. Shedding is an early indicator of infection; the body then starts its fight against the virus. Could the shedding pose a risk of infecting other astronauts on the flight?

## Simple Procedures, High Payoff

Ideally, answering the questions in Pierson's two experiments would require astronauts' saliva, urine, and blood to be sampled *daily* before, during, and after flight to look for the presence or absence of stress hormones and herpesviruses and the concentration of different types of white blood cells.

But daily blood testing is impractical. In addition to the annoyance to astronauts of enduring needles every day, "there are lots of technical constraints" to the analysis of fresh blood samples in flight, Pierson notes. For one thing, "the analytical equipment is bulky and will not operate in microgravity." Blood samples could be collected in flight and refrigerated until returned to Earth for later analysis, but that's of no help because "many cells will die or change their functions." So, to measure the action of white blood cells, Pierson and his colleagues are limited to obtaining blood samples from astronauts on the ground — during their flight physicals 10 days before launch, the day of their landing, three days and two weeks after landing, and during their routine annual physicals a year or so after flight.

Collecting urine and saliva in flight and preserving them until landing to test for stress hormones and latent viruses, however, is another matter. "The viruses don't die or change, even over 60 days, and they don't have to perform a

function. They just need to say 'present' when we call roll," Pierson quips. Thus, once in flight, the STS-107 astronauts will have a small extra task each day right after they wake up: "They'll take a cotton dental roll, put it in their mouth, roll it around to collect saliva, and put it in a Ziploc bag that has a little preservative to keep the bacteria down." The bag doesn't even have to be frozen or refrigerated.

Back on Earth, the saliva and urine specimens are analyzed by a process called the polymerase chain reaction for the presence of viral-specific DNA. The concentration of latent viruses in the saliva during flight will be compared with the concentration measured in samples taken six months before flight, three times a week for a month before flight, and every day for two weeks after flight. A similar simple procedure will be followed for urine samples.

Although Pierson and his colleagues have conducted various individual blood or saliva tests with space shuttle astronauts on some two dozen previous flights over the past decade, STS-107 will be the first opportunity to comprehensively measure components of the immune system, viral reactivation, and stress hormones simultaneously — and whether the amount of immune-system suppression is medically as well as scientifically significant. "It's a very exciting mission," Pierson says. "This will be our most comprehensive baseline to date."

*Trudy E. Bell*

Pierson's co-principal investigator for the immune response experiment is Indresh Kaur, and for the latent virus experiment Satish Mehta, both from Enterprise Advisory Services Inc. at the Johnson Space Center. For more information on Pierson's research on STS-107, visit [http://spaceresearch.nasa.gov/sts-107/107\\_Immune.pdf](http://spaceresearch.nasa.gov/sts-107/107_Immune.pdf) and [http://spaceresearch.nasa.gov/sts-107/107\\_virus.pdf](http://spaceresearch.nasa.gov/sts-107/107_virus.pdf). For results of research on previous flights, see [http://www.psychosomatic.org/press\\_releases/016.html](http://www.psychosomatic.org/press_releases/016.html) and <http://www.asma.org/Publication/abstract/v70n12/v70n12p1211.html>.



*Fishing for Clues continued from page 15*

the problems that they have resolve themselves.”

## Beyond 0 g

“It’s been relatively easy to start making analogies to the visual system for the vestibular system,” says Moorman. “That’s what drives all of this research. But bear in mind that there isn’t a single living thing on Earth that evolved in the absence of gravity, so we have no idea what role gravity plays in *any* developmental process. We know that animals can develop in microgravity and they seem to do just fine, but we don’t know whether microgravity has had some effects on things like gene expression,” he adds.

The opportunity to refine microgravity experiments through repeated iterations in ground-based laboratories using the bioreactor is key to advancing the research. “A lot of the questions I wanted to ask about the vestibular system have already been answered for a lot of other parts of the nervous system,” says Moorman. By interacting with other researchers working on zebrafish and other vertebrates, Moorman availed himself of their expertise: “I could pick their brains about what experiments they did that didn’t work, so I didn’t

have to try them on the vestibular system.”

After fine-tuning the experiments, the next step is to take them to the space station. “That would confirm what we know from the bioreactor,” explains Moorman, and would eliminate most concerns about drawing conclusions based on simulated versus real microgravity. By using a centrifuge on the space station and the bioreactor on Earth, a full range of gravitational forces can be examined. “From there,” says Moorman, “We can do a dose-response curve and predict what the effects of different gravitational fields might be on other planets. In that respect, the space station provides us with a more flexible set of tools.”

## “It’s Going to Take a Village...”

Even if Moorman and his team are able to describe in detail the effects of varying gravity levels on the developing vestibular system, that will solve just one piece of a very complex puzzle. “It’s going to take a village of scientists, all collaborating, to complete the picture,” says Moorman. Because of the

availability of the bioreactor and the number of researchers already studying zebrafish, Moorman believes that a coordinated effort can be made to understand microgravity’s effects on the developmental process. “We have an opportunity to do a lot more experiments every single day. And what that allows us to do is really refine our experiments, so that when we fly an experiment on the space shuttle or on the space station, we actually get it right.”

*Jacqueline Freeman-Hathaway*

For additional information, visit Stephen Moorman’s web site at <http://www2.umdj.edu/~moormasj/>. Moorman’s research on the critical period for vestibular development was published in Moorman, S.J., R.Cordova, S.A. Davies (2002). A critical period for functional development of the zebrafish (*Danio rerio*) vestibular system. *Developmental Dynamics*, 223, 285–291. A zebrafish database maintained by the University of Oregon includes information on the mapping of genes in the species, lists of publications on zebrafish, where to find researchers working on zebrafish, and resources for teachers K–12 interested in bringing zebrafish research to the classroom. The database can be found on the WWW at [http://zfin.org/cgi-bin/webdriver?Mlval=aa-ZDB\\_home.app](http://zfin.org/cgi-bin/webdriver?Mlval=aa-ZDB_home.app).

*From Child’s Toy to ISS continued from page 19*

one point on the equator. While perfect for television, these satellites are awkward for voice communication, because the lag time is too great to conveniently carry on conversations. Although satellites that have low orbits would be perfect for communications (because there would be virtually no lag time in receiving signals), their 90-minute orbit puts batteries through so many charge-discharge cycles that, like those on the space station, they wear out in four to five years. This makes the satellites not very commercially viable. Flywheel batteries could open up a whole new market for low-orbiting satellites.

In addition to working with the commercial space industry, Palazzolo and his team have worked with several ground-based commercial partners, assisting them in developing better systems. One of CSP’s most promising ground-based projects is with the Federal Rail Association and the Center for Electromechanics (CEM) at the University of Texas, Austin. Together, these partners are developing applications for flywheels in trains.

“The CEM intends to reuse energy from braking,” says Palazzolo. “With one of these flywheels in a subway train, each

time it comes to a stop, instead of losing all the energy to heat in the brakes, it is stored in the flywheel. Then, when the train leaves the station, it uses that same energy and really improves the efficiency,” explains Palazzolo. “There has been considerable effort and investment for applying this regenerative braking scheme to automobiles. Hopefully this will have a big payback in cleaner air and less dependence on foreign oil.”

*Carolyn Carter Snare*

For more information on the Center for Space Power, look up <http://engineer.tamu.edu/tees/csp/> on the World Wide Web.

# Profile: Rafat Ansari

*A career in fluid physics has led Rafat Ansari to develop technology that has benefited NASA research and become a new tool for diagnosing cataracts.*

**A** NASA researcher in fluid physics and biomedical optics at Glenn Research Center in Cleveland, Ohio, Rafat Ansari develops technology that will potentially help astronauts as well as enhance the health of people on the ground. Ansari joined NASA in 1988, first as a contractor and later as a NASA employee, but he would tell you that he set his sights on space long before then.

Ansari was raised in Karachi, Pakistan, by parents who were avid readers and deeply interested in the world around them. His earliest memories are of his father discussing the Russian space program. "When I was only about five years old, and the Sputniks went into orbit," Ansari says, "my father would bring home these *Life* magazines, and I would read the stories to him. I grew up with the space program."

One space mission in particular was to have a great impact on his life. "What really shaped my future was the *Apollo 11* landing in 1969," Ansari says. "My father was listening to the Voice of America, and my mother was praying for the safety of the astronauts because we heard that they had landed, but Neil Armstrong did not get out for at least six hours. Hearing the words 'The *Eagle* has landed' was really the defining moment in my life that led me to become a physicist."

Although his parents wanted him to be a doctor or an engineer, he held to his childhood decision and went into fluid physics. He earned a bachelor's degree from the University of Karachi, Pakistan; two master's degrees, one from the University of Calgary, Alberta, Canada, and the other from the University of Karachi; and a doctorate from the University of Guelph and University of Waterloo, Ontario, Canada.

His early research was in cryogenics, the production and maintenance of low temperatures. He progressed from cryogenic fluids to colloids (suspensions of minute particles in a fluid) and other complex or polymeric (having long-chain molecules) fluids. "My graduate program was in fluid physics as it relates to biophysics," he says. "If you look at the human body, you see it is essentially made of proteins and fluid (water), both of which play very important roles in the body."

Before he joined NASA in 1988, Ansari worked for the Canadian Department of Energy, Mines, and Resources, conducting research on flocculation (the aggregation of suspended materials by the addition of long-chain polymers), a process used to control water pollution. Ansari developed a laser light-scattering device to help study these suspended materials. When he started working at NASA, this experience was very useful. He explains, "One of the NASA objectives at the time was to use these laser light-scattering devices on the space shuttle or in the space station to study protein crystal growth and colloid experiments."

Ansari's research focus shifted drastically soon after he joined NASA. In 1989, he returned to Pakistan to visit his family and found that his father had recently been diagnosed with cataracts. Ansari was surprised to learn that not only is there no treatment for cataracts except surgery, but doctors don't even know why they form. He discovered that cataracts are caused by the agglomeration of protein crystallines in the lens of the eye. "At that time, I was working on characterizing the crystallization of proteins in solution for a space experiment," Ansari recalls, "so I said, well, if I can do that, then we should be able to look at this, too."

Ansari went to a local slaughterhouse and bought cow eyes to study how the light-scattering device might be adapted for use on the eye. Having no experience with dissection, he turned to his daughter Rahila, who had some knowledge from school. "We did some experiments, essentially in the kitchen of the house, and then everything just took off from there," Ansari explains.

His efforts eventually resulted in a device that can detect cataracts much earlier than conventional methods. The probe is currently in clinical trials at the National Eye Institute at the National Institutes of Health in Bethesda, Maryland, and might be used to detect other diseases as well. It is of interest to NASA because studies have shown that exposure to radiation in space places astronauts at a higher risk for developing cataracts.

Ansari's research now focuses on the further development of this probe for use in early detection of both eye and systemic diseases. His research into fluid physics



credit: NASA

continues, including an experiment on zeolite synthesis (zeolite crystals are useful in many industries and grow better in microgravity than on Earth). But his work on the ocular probe and related technology occupies much of his professional time. He is flying experiments on NASA's KC-135 parabolic aircraft to measure ocular blood flow in weightlessness. He is also an adjunct professor at Drexel University, Philadelphia, Pennsylvania, and is serving on the editorial boards of several scientific journals. Ansari is a recipient of the NASA Public Service Medal and a Space Act Award.

Ansari's life has in many ways come full circle. When he was a child, his father encouraged his curiosity about the world around him and introduced him to his lifelong passion — spaceflight. As a father himself, Ansari has passed his curiosity on to his daughter and introduced her to the world of scientific research. She will soon receive her doctorate in biomedical engineering and has started medical school. For Ansari himself, to be able to work for NASA and help develop technology for future missions is more than he ever imagined. As he is fond of saying, "If you can dream it, you can do it."

*Carolyn Carter Snare*

For additional information, contact Rafat Ansari via e-mail at [Rafat.R.Ansari@grc.nasa.gov](mailto:Rafat.R.Ansari@grc.nasa.gov). Information on his optical research is available at <http://mgnews.msfc.nasa.gov/fall96/fall96lead.html> and <http://mgnews.msfc.nasa.gov/winter96/winter96coe.html#A.1.4>.



National Aeronautics and  
Space Administration

**Marshall Space Flight Center**  
Building 4201, SD13  
Marshall Space Flight Center, AL 35812



# Space Research

Office of Biological and Physical Research

<http://spaceresearch.nasa.gov>