

NYBOT®
SUGAR NO. 14
TABLE OF CONTENTS

Rule	Subject
14.00	Contract Terms—Forms
14.01	Delivery Months
14.02	Size of Contracts Price Fluctuation Limits
14.03	Contract Binding
14.04	Last Trading Day
14.05	Delivery
14.06	Delivery Documents
14.07	Passing of Title to Sugar
14.08	Insurance
14.09	Discharge
14.10	Weights and Tests
14.11	Testing Samples
14.12	Polarization Allowances
14.13	Variations from Standard Quality
14.14	Deficiencies or Excesses
14.15	Damage to Sugar
14.16	Strikes or Lockouts Affecting Delivery
14.17	Tax Liability
14.18	Notice of Failure to Meet Obligations
14.19	Orders Subject to Exchange By-Laws and Rules
14.20	Clearing Member Open Position Reports to Clearing Association

SUGAR NO. 14 RESOLUTIONS

No.	
1	Color Test Procedures for Sugar: I.C.U.M.S.A. Color Units Method 4 (1978) Modified
2	Determination of Dextran
3	Use of Valid Raw Sugar Re-Export Licenses

SUGAR NO. 14 RULES

Rule 14.00. Contract Terms—Forms

(a) No Contract for the future delivery of Sugar No. 14 shall be recognized, acknowledged or enforced by the Exchange, or any Committee or officer thereof, unless both parties thereto shall be Members of the Exchange, provided, however, that Members shall offer their contracts for clearance to the Clearing Organization which shall become by substitution a party thereto in place of a Member, and thereupon such Clearing Organization shall become subject to the obligations thereof and entitled to all the rights and privileges of a Member in holding, fulfilling or disposing thereof.

(b) The grades deliverable under Sugar No. 14 shall be raw centrifugal cane sugar based on 96 degrees average polarization outturn, Standard Quality Range as stated below or otherwise as provided in Rules 14.12 and 14.13:

Moisture Standard Quality Range

Factor of Safety

(High number indicates low quality) Not exceeding 0.30

Ash

Ash Content Maximum and minimum standard ash content is derived by multiplying (percent of raw sugar) percent non-sucrose solids by the factor listed below which corresponds to the final polarization of the cargo:

	MAXIMUM	MINIMUM
Up to and including 98.0°25	.17
Over 98.0° up to and including 98.2°26	.18
Over 98.2° up to and including 98.4°27	.19
Over 98.4° up to and including 98.6°28	.20
Over 98.6° up to and including 98.8°29	.21
Over 98.8° up to but not including 99.0°30	.22

Grain Size

Percent through 28 mesh Tyler (30 mesh U.S.) sieve.

(High number indicates low quality) Between 52 and 22

Color-Affined Raw

I.C.U.M.S.A. Color Units Method 4 (1978), Modified*

(High number indicates low quality) Between 800 and 1500

Color-Whole Raw

I.C.U.M.S.A. Color Units

Method 4 (1978) Modified* Between 3000 and 6000

Dextran Not exceeding 250 M.A.U.

For the purposes of determining whether sugar meets the foregoing specifications for standard raw sugar quality and calculating the premiums and discounts specified in Rule 14.13 hereof, an average test result shall be used. Such average shall be determined for each quality specification separately and shall be the average of the two nearest test results of the three laboratories, but if the two are equidistant from the median, then the median shall be used.**

* See Sugar No. 14 Resolution No. 1.

* See Sugar No. 14 Resolution No. 1.

** See Sugar No. 14 Resolution No. 2.

There shall be no premium or discount for variance from standard quality for sugar polarizing at 99 degrees or higher, except for dextran.

(c) The Sugars deliverable under Sugar No. 14 are as follows:

(i) Foreign growth cane sugars of less than 99.5 degrees polarization, duty and import fee, if any, paid; and

(ii) Cane sugars, the product of the United States and its Customs territories;

provided, however that no lot of fifty (50) tons is to consist of Sugar from more than one country of origin.

(d) No delivery of Sugar is permitted testing below 94 degrees. No delivery is permitted of Sugar which is not eligible for classification as raw sugar if required under the provisions of any existing United States legislation and the Deliverer shall be responsible for any penalties hereby assessed by any United States Government Department or Agency.

(e)

Contract No. 14

New York _____ 20 _____

(has) (sold)

(have) this day (bought)

(deliver to)

and agreed to (receive from) _____ fifty (50) tons of two thousand two hundred forty (2,240) pounds each of Raw Centrifugal Cane Sugar, in bulk, of any grade or grades and qualities as specified in Rule 14.00 at the price of _____ cents per pound net cash duty and import fee, if any, paid or duty free. Such price to be for 96 degrees average polarization outturn, and Standard Quality Range, with additions or deductions for other grades and qualities according to the differentials established or to be established for the delivery month stated below by the Rules of the Exchange, adopted or to be adopted in accordance with the provisions of Rule 14.00.

Deliverer shall deliver and Receiver shall receive the Sugar in a vessel berthed at a customary Refiner's Berth equipped with the necessary weighing and sampling facilities in New York (including Yonkers), Baltimore, New Orleans (including Gramercy, Burnside and Reserve), Savannah (Port Wentworth), or Galveston during the month of _____ 20 _____. The port and berth shall be declared by Receiver, who shall discharge the sugar as customary at said berth at his own expense in accordance with Rule 14.09(c).

So long as Sugar may be processed or consumed only under any quota or allotment plan decreed by any United States Government Department or Agency only sugar permitted to be so processed or consumed without penalty on the date of delivery under this contract may be delivered in fulfillment thereof. If it is required that Sugar delivered hereunder be classified as raw sugar under any plan decreed by any United States Government Department or Agency, the Receiver hereby guarantees that all Sugar delivered hereunder shall, following its entry into the continental United States, be subjected to required specific processes.

The stevedoring allowance is to be determined in accordance with Rule 14.09(c).

This contract is made in view of, and in all respects subject to the Rules of the Exchange.

(Brokers)

(Across the face is the following)

For _____ and _____ in consideration of One Dollar to _____ in hand paid, receipt whereof is hereby acknowledged _____ accepts this contract with all its obligations and conditions.

(f) From time to time, as it may deem appropriate, the Domestic Sugar Committee shall report to the Board schedules of differentials in respect of Sugar deliverable under the Sugar No. 14 Contract, which differentials, at the time of said report, shall reflect as nearly as practicable the differentials for equivalent variations in Sugar in the spot market. The Domestic Sugar Committee, in its discretion, may report with respect to differentials relating to polarization alone, or to elements of quality alone, or to both. Based upon the report of the Domestic Sugar Committee and such other information as it may deem appropriate, the Board shall determine differentials for the Sugar deliverable under said Contract (dealing, in its discretion, with differentials relating to polarization alone or to elements of quality alone or to both), which differentials, at the time, shall reflect as nearly as practicable the differentials for equivalent variations in Sugar in the Spot Raw Sugar Market. If the differentials so determined (whether relating to polarization alone or to elements of quality alone or to both) shall be different from those currently in effect, the Board shall set forth such changed differentials or eliminate same entirely, in a resolution adopted as provided in **Section 601 of the By-Laws**[, except that the ten (10) day period of posting may be reduced at the discretion of the Board and any request for a second reading may be denied.]. Such rule or rules and the differentials therein set forth or eliminated shall become effective and be applicable with respect to deliveries of Sugar in and after such delivery month as the Board may determine and shall govern deliveries under all Sugar No. 14 Contracts then existing as well as those thereafter entered into.

Rule 14.01. Delivery Months

Sugar No. 14 Contracts shall not be recognized by the Exchange extending beyond a period of eighteen (18) months, including the current month. Trading shall be permitted only for the delivery months of January, March, May, July, September and November and shall at all times be conducted in any such month contained in an eighteen (18) month cycle. Trading in a new delivery month shall be initiated at the opening of trading on the first (1st) Business Day of the seventeenth (17th) month preceding any delivery month.

Rule 14.02. Size of Contracts; Price Fluctuation Limits

(a) All offers to buy or sell Sugar for delivery under The Sugar 14 Contract, unless otherwise specified, shall be understood to be for fifty (50) tons of two thousand two hundred forty (2,240) pounds each of, and offers to buy or sell in larger quantities shall be in multiples thereof.

(b) All offers to buy or sell Sugar for delivery under The Sugar 14 Contract, shall be in cents and one one-hundredths of a cent, and no transaction in Sugar No. 14 Contracts shall be permitted wherein the difference in price shall consist of a fraction smaller than one-hundredth of one cent per pound, nor shall any additional moneyed consideration whatever be allowed.

(c) To avoid abnormal fluctuations of price and injurious speculation incident thereto, the Board of Governors may, if and to the extent it deems desirable, impose, increase, decrease, change, suspend or eliminate limits on daily price fluctuations of The Sugar No. 14 Contract in any month or months, and prescribe the terms and conditions of any such limits.

Rule 14.03. Contract Binding

(a) All Sugar No. 14 Contracts shall be binding upon Members and of full force and effect until the quantity and quality of the Sugar specified in such contract shall have been delivered, and the price specified in said contract shall have been paid. No Sugar No. 14 Contract shall be entered into with any stipulation or understanding between the parties at the time of making such contract that the terms of said contract as specified above are not to be fulfilled, or that the Sugar is not to be delivered and received in accordance with the Rules.

(b) Subject to the prohibition in paragraph (a), the Deliverer and Receiver may enter into a mutually acceptable written agreement to deliver and receive under conditions other than those stipulated in the Rules. A delivery so made shall be considered complete upon written notification by the Deliverer and the Receiver to the President and to the Clearing Organization. The making of any such agreement shall relieve the Clearing Organization of any further obligations with respect to any Sugar No. 14 Contract involved, and the Deliverer and Receiver shall indemnify the Exchange and the Clearing Organization against any liability, cost or expense either may incur for any reason as a result of the execution, delivery or performance of such contract or such agreement, or any breach thereof or default thereunder.

Rule 14.04. Last Trading Day

(a) The Last Trading Day for each delivery month in the Sugar No. 14 Contract shall be the eighth (8th) calendar day of the month preceding the delivery month, provided, however, that if said day is not a Business Day then the Last Trading Day shall be the next succeeding Business Day.

(b) After the close of business on the Last Trading Day of any delivery month:

(i) Each Member holding one (1) or more open sales contracts for that month shall issue a "Memo of Deliverer" to the Clearing Organization, by 5:00 P.M., stating the total number of open sales contracts for that month (which number shall conform to the unliquidated position on said Member's books) which it will be delivering.

(ii) Each Member holding one (1) or more open purchase contracts for that month shall issue a "Memo of Receiver" to the Clearing Organization, by 5:00 P.M., stating the total number of open purchase contracts for that month (which number shall conform to the unliquidated position on said Member's books) which it will be receiving.

(iii) Notwithstanding the foregoing provisions of this paragraph (b), if a Member transfers any contracts after the close of trading in accordance with **Rule 4.11(e)**:

(A) The failure of such Member to issue a Memo of Deliverer or Memo of Receiver with respect to such contracts shall not be deemed a violation of this paragraph (b);

(B) If any contracts transferred offset any contracts with respect to which the transferee had issued a Memo of Deliverer or Memo of Receiver, such Memo shall be deemed amended to reflect the deletion of the contracts so offset; and

(C) If any contracts transferred do not offset any contracts with respect to which the transferee had issued a Memo of Deliverer or Memo of Receiver, the transferee shall issue a Memo of Deliverer or Memo of Receiver with respect thereto by 5:00 p.m. of the Business Day following such Last Trading Day.

(c) The Clearing Organization, after receiving the Receiver's and Deliverer's Memos shall issue to each Receiver, before 10:00 A.M. of the following Business Day, a "Multiple Delivery Notice" for the number of contracts reported outstanding. Contracts listed on Multiple Delivery Notices may not be transferred or exchanged among Members.

(d) Not later than 3:00 P.M. of the day specified in paragraph (c), each Receiver holding a Multiple Delivery Notice shall notify, in writing, each Deliverer and the Clearing Organization of the name or names of the Deliverer or Deliverers, and the number of contracts the Receiver will be receiving.

(e) The notice price for Multiple Delivery Notices issued with respect to any delivery month shall be the Settlement Price for said delivery month on the Last Trading Day for that month.

(f) If the office of a party to whom a Memo of Deliverer, Memo of Receiver, Multiple Delivery Notice or other written notice under this Rule is to be given is closed, it shall be sufficient to give such document to the Clearing Organization, which shall endorse thereon the day and time of receipt. Notice thereof shall be posted on the web site of the Exchange.

Rule 14.05. Delivery

(a) Each Receiver shall on or before 3:00 P.M. of the fifteenth (15th) calendar day of the month preceding the delivery month, provided if same is not a Business Day then on the next succeeding Business Day, declare to the Deliverer, in writing, one (1) of the following options for each delivery notice received:

- (i) North of Hatteras (New York including Yonkers, or Baltimore).
- (ii) New Orleans (including Gramercy, Burnside and Reserve).
- (iii) Savannah (Port Wentworth).
- (iv) Galveston.

(b) The Deliverer shall declare to the Receiver, in writing, not later than fourteen (14) calendar days prior to the day the vessel is expected to arrive for delivery, except that said declaration is not required to be made any earlier than noon of the next Business Day after the date specified in paragraph (a) above:

- (i) the name of the carrying vessel, its itinerary and approximate date of arrival;
- (ii) the country of origin of Sugar being delivered;
- (iii) the total number of contracts being delivered on this vessel;

(iv) the amount of other sugar or other cargo, if any, being carried by the vessel and if such sugar or other cargo is to be discharged at the same port as declared under this paragraph, the discharge rotation of same; and

- (v) the name of the owners or chartered owners or their agents.

(c) On or before 3:00 P.M. of the day notification is required under Bulk Sugar Charter—U.S.A. (April 1962—Revised), each Receiver shall declare to the Deliverer, in writing, for each contract the port and berth within such port at which Sugar is to be received, except if such day is not a Business Day, then such Declaration shall be made on the preceding Business Day. If the carrying vessel is scheduled to arrive at the discharge port before the first (1st) calendar day of the delivery month, then for the purpose of this paragraph the expected arrival date shall be the first (1st) calendar day of the delivery month.

(d) If it becomes evident that the carrying vessel declared to the Receiver, due to causes beyond the Deliverer's control, will be unable to arrive in time to fulfill the contracts, the Deliverer must promptly advise the Sugar Delivery Committee of such fact. The Deliverer may, within two (2) Business Days, and upon the approval of the Sugar Delivery Committee and on such conditions, if any, prescribed by the Sugar Delivery Committee, substitute other Sugars which would be good tender under the contract.

(e) Delivery under this contract shall be considered timely delivery if the vessel carrying the Sugar reports ready to discharge at its first (1st) Sugar delivery berth not later than 8:00 A.M. on the last Business Day of the delivery month. If there is more than one (1) Receiver on any one (1) vessel, the rotation of discharge shall be determined by number of contracts for each Receiver, the largest number of contracts being first (1st) and the smallest number of contracts being last. However, if a carrying vessel is ordered to discharge at more than one (1) port or more than one (1) berth in any port, all Sugars to be delivered at one (1) port or one (1) berth must be discharged before proceeding to a second (2nd) port or

berth. If the vessel reports ready for discharge after the fifth (5th) Business Day prior to the last Business Day of the month, discharge of the Sugar to be delivered against Exchange contracts must be completed prior to the discharge of any other sugar or other cargo.

Rule 14.06. Delivery Documents

(a) The Deliverer shall present to the Receiver the following documents:

(i) Full set 3/3 original, clean, on board ocean or charter party bills of lading signed by Master or Agents, blank endorsed or endorsed to the order of the Receiver;

(ii) Special Customs Invoice or Customs Extract;

(iii) Generalized System of Preferences, Certificate of Origin Form A or Caribbean Basin Initiative Certification of Origin, if applicable;

(iv) Insurance certificate or policy covering marine and war risk insurance in accordance with Rule 14.08;

(v) Certificate for Quota Eligibility, if required for timely entry by U.S. Customs; and

(vi) Pro forma invoice for ninety-five percent (95%) of the total price of 112,000 pounds of Sugar of 96 degrees polarization and Standard Quality Range, for each contract at the Multiple Delivery Notice price reduced by the applicable rate of United States Customs duty and/or import fee on such 96 degree sugar, if any, and with the deduction of the stevedoring allowance as per Rule 14.09(c).

(b) Deliverer shall present said documents to Receiver not sooner than seven (7) calendar days nor later than two (2) calendar days prior to the latter of either:

(i) the expected arrival date of the carrying vessel at the discharging port; or

(ii) the expected date the Sugar being delivered under the Sugar No. 14 Contract will be available for discharge when any sugar or other cargo is scheduled for prior discharge.

(c) With respect to pro forma settlement:

(i) Receiver will pay the pro forma invoice value between the hours of 10:00 A.M. and 3:00 P.M., without any set-off or deduction whatsoever, within one (1) hour after presentation by Deliverer which shall be not later than 2:00 P.M. on the Business Day (providing normal New York banking facilities are available) that the documents are presented as above. Unless otherwise mutually agreed payment shall be made by wire transfer in same day funds.

(ii) At the time pro forma settlement is made:

(A) the Deliverer and Receiver jointly must notify the Clearing Organization in writing of such pro forma settlement.

(B) the Deliverer or Receiver, as the case may be, must return to the other party the net amount of variation Margin collected from the time the delivery notice is issued. Unless otherwise mutually agreed, the return of variation Margin shall be made by wire transfer in same day funds.

(d) In the event the Deliverer is unable to make timely presentation of any of the documents enumerated in paragraph (a) above, the Sugar Delivery Committee shall be notified accordingly. The Sugar Delivery Committee may, after consultation with the Deliverer and Receiver and any other interested parties, authorize a substitution for any of said unavailable documents or grant a waiver or delay in presentation of any said documents in order that pro forma payment may be effected as per paragraphs (b) and (c) above. However, in the case of the Certificate for Quota Eligibility, the Sugar Delivery Committee, before authorizing any substitution or granting any waiver, must ascertain that U.S. Customs will permit the timely entry of the Sugar into the United States under the applicable quota of the country of origin. Should the Sugar Delivery Committee determine that any cost or expenses were incurred by

reason of said authorizations or waivers, they shall order payment by the Deliverer of said costs or expenses.

(e)(i) In the event the Deliverer has not paid for the Sugar being delivered and does not possess documents of title to such Sugar, but wishes the discharge of such Sugar to commence in an orderly fashion, the Deliverer may authorize the Sugar Delivery Committee to instruct the Receiver to make the appropriate pro forma payment to the Clearing Organization to be held in escrow for the account of the Deliverer, provided that the Deliverer furnishes to the Receiver such collateral or bank guarantees as may be necessary, in the judgment of the Sugar Delivery Committee, to enable the Receiver to finance such payment.

(ii) Upon receipt of satisfactory proof of payment and possession of documents of title, the Sugar Delivery Committee shall then authorize the Clearing Organization to make the appropriate pro forma payment to the Deliverer. In the event of payment as above, the date of payment as stipulated in paragraph (g) below shall be the date payment is made by the Receiver to the Clearing Organization.

(f) All United States Customs duties or import fees required to be paid upon entry of the Sugar into the United States shall be paid or caused to be paid by the Receiver and shall be deducted from the contract price. The rate at which said duties or import fees are paid shall be the applicable rate of duty or import fee used in Rule 14.06(a)(vi) above.

(g) In the final settlement of the Sugar delivered, the Deliverer shall pay the Receiver interest on the pro forma invoice amount at the prevailing New York prime rate as determined by the Sugar Delivery Committee for the period commencing with the date of payment as above up to the tenth (10th) day (or, if such day is not a Business Day, on the next following Business Day) following the day of arrival of carrying vessel. For the purpose of this contract, the "day of arrival of carrying vessel" shall be the day on which vessel last passes or is released from Quarantine at destination port, except that if vessel passes or is released from Quarantine after 5:00 P.M. or if such day is not a Business Day, then the next succeeding Business Day provided, however, if the vessel is carrying any other cargo or other sugar not being delivered under the Sugar No. 14 Contract, either of which is to be given prior discharge at the same destination then, based on the available information the Sugar Delivery Committee shall designate the "day of arrival of the carrying vessel" for the purpose of this paragraph.

(h) Final settlement shall be made promptly after weights, polarizations and quality tests are ascertained. As soon as final settlement has been made, the Deliverer and Receiver jointly shall notify, in writing, the Clearing Organization, of such final settlement.

Rule 14.07. Passing of Title to Sugar

Title to, and risk of loss in, the Sugar delivered under the Sugar No. 14 Contract shall pass from the Deliverer to the Receiver at the time pro forma payment is made in accordance with the contract.

Rule 14.08. Insurance

(a) MARINE AND WAR RISK INSURANCE, with loss payable to Receiver from time title and risk of loss passes to Receiver and to Deliverer prior to title and risk of loss passing to Receiver, shall be procured and maintained by Deliverer at expense of Deliverer, on all Sugar delivered hereunder. The marine policy shall cover all risks of physical loss or damage from any external cause, including loss of weight and polarization resulting from perils insured against, but excluding all claims for differences between bill of lading and outturn weights unless actually resulting from perils insured against, in which event the quantitative loss shall be determined as described below, and further excluding (except as hereinafter provided) those risks excluded by the F.C.&S. and the S.R.&C.C. Warranties of the American Institute of Marine Underwriters; shall, as to Sugar delivered hereunder and shipped on any vessel, cover against strikes, riots and civil commotions; shall include customary on-shore coverage until completion of discharge of such Sugar at destination port and delivery into warehouse as directed by Receiver. The war risk policy, and the strikes, riots and civil commotions clauses as to sugar delivered hereunder and shipped

on any vessel, shall be in accordance with American Institute of Marine Underwriters' policy provisions and clauses current as of the time the Sugar becomes at risk thereunder. For the purpose of payment of losses and premiums, the marine and war risk policies shall provide that the Sugar delivered hereunder shall be valued at the total amount payable by Receiver to Deliverer therefor plus five percent (5%) thereof. Furthermore, such policies shall provide that for the purpose of establishing the amount of loss in the case of Sugar damaged by perils insured against under this insurance:

(i) the quantitative loss shall be determined as the difference between (1) the outturn weight and (2) bill of lading weight, less the normal loss in weight as determined by the Refiner's records for the last three (3) sound arrivals of raw centrifugal sugar from the same country of origin during the twenty-four (24) months preceding arrival; in the case of an insufficient number of previous sound arrivals, normal loss in weight is deemed to be three-fourths of one percent;

(ii) Sugar damaged to such extent that it cannot reasonably be discharged by Refiner's normal discharging equipment and methods or contaminated to such extent with oil or other substances that it cannot practicably be taken into Receiver's refinery shall be deemed a salvage loss; and

(iii) other damaged Sugar shall be valued by adjusting the 96 degrees basis price in accordance with the scale set forth in Rule 14.12, except that if the polarization of the damaged Sugar is less than 94 degrees, there shall be deducted five percent (5%) additional for each degree thereafter, or pro rata in each case for fractions of a degree. If any shipment is lost, or if the quantity of sound Sugar discharged from any shipment is insufficient to permit a determination of average outturn polarization and quality, the quality shall be assumed to be standard and the polarization shall be determined (1) on the basis of the most recent available outturn polarization of sound sugar of the same crop shipped from the same shipping terminal or port which was discharged at a Continental United States port; or if such is not available, then (2) on the basis of assumed 96 degree polarization. For these purposes a shipment not proved to have been lost shall, unless vessel's position and safety are currently reported, nevertheless be deemed lost if it fails to arrive at destination port within seventy-five (75) days after it was loaded aboard vessel at origin and an onboard bill of lading was issued with respect thereto. The outturn weight of any shipment to which the foregoing applies shall be deemed to be its bill of lading weight. Receiver shall be obligated to reimburse Deliverer for any additional insurance premium payable solely because Receiver, for its convenience, delays the discharge of such sugar at destination port.

Rule 14.09. Discharge

(a) The Deliverer shall guarantee that the Sugar shall be delivered and the Receiver shall guarantee that the Sugar shall be received under the terms and conditions (except as provided in the paragraphs below) of the freight agreement known as Bulk Sugar Charter Party U.S.A.—April 1962 or any amended form of such freight agreement, and such conditions which the Board of Governors, in its discretion, may from time to time determine to be appropriate to make such amended form of freight agreement fair and equitable between the parties.

(b) No liberty or car carrier type vessel may be used to carry Sugar delivered under the Sugar No. 14 Contract.

(c) The Receiver shall discharge the Sugar at his designated berth at his own expense. However, the amount the Deliverer shall allow the Receiver for the discharge of Sugar under Sugar No. 14 Contract, known as the stevedoring allowance, shall be calculated as follows:

(i) By September 15th of each year, or as soon thereafter as the information is available, the Exchange will collect from each refiner, located at ports authorized by Sugar No. 14 Contract for the discharge of Sugar, the allowance they are applying to all deliveries after October 1st of that year.

(ii) Tonnage shipped to the above refiners for the period July 1st of the prior year through June 30th of the current year will be collected from an Exchange licensed sugar weighmaster. From this data market shares by refinery will be calculated to the nearest one-tenth of one percent (.1% = 1/1,000).

(iii) The weighted average of the discharge allowances collected in step (i) above will be calculated by the Exchange, with the weights equal to the market shares from step (ii) above. The calculated weighted average will be rounded to the nearest whole cent per ton and this will be the Sugar No. 14 stevedoring allowance for all deliveries after October 1st of that year. The rate will be posted on the Exchange web site.

**[Stevedore Rate effective October 1, 2003 through September 30, 2004:
\$12.45 per Long Ton]**

(d) The Receiver may deduct from the final settlement to the Deliverer all discharging charges applicable to the vessel, including but not limited to, wharfage, water, despatch, noncompliance and/or extra stevedoring. The Receiver shall reimburse the Deliverer for any demurrage incurred in discharge. The Deliverer shall pay the freight, discharge all liens and make all settlements with the vessel or its owners. If an arbitration proceeding should arise under the charter party, Receiver shall, upon Deliverer's request, consent to become a party to the arbitration and shall be bound by any award against the Receiver in the proceeding.

Rule 14.10. Weights and Tests

(a) The Receiver shall advise the Deliverer as to the name and location of the refinery and the Receiver shall nominate the Weighers and Samplers employed by such refinery to act for him in determining the weight and test of the Sugar. The Deliverer shall advise the Receiver of the name of the Weighmaster and Sampler (licensed by the Exchange) who will act in his behalf.

(b) All Sugar weighed for delivery on the Exchange, shall be weighed and checked as customary at such Refinery. Acting for the Deliverer, the Weighmaster shall weigh the Sugar in the presence of, and the weights shall be checked by, the representative of the Refinery who shall endorse on the Weighmaster's weight certificate the following:

I hereby certify that the weights of the sugar specified in this return agree with those checked by me at the time of weighing.

Refiner's Representative

(c) Prior to the commencement of weighing, the scales shall be tested as customary at said Refinery.

(d) By mutual consent between Receiver and Deliverer and where it is customary at the receiving Refinery, the Weighmaster may represent both parties. However, the endorsement referred to in (b) above shall be signed by the Weighmaster as the Refiner's representative.

Rule 14.11. Testing Samples

(a) On all Sugar delivered hereunder, samples shall be drawn as customary at such Refinery. Sugar samples shall be tested by three chemists, one selected by the Deliverer and one by the Refinery representative acting on behalf of the Receiver, and by the chemist of the New York Sugar Trade Laboratory. The average of the two (2) nearest polarizations, or if the two (2) are equidistant from the median, then the median, shall be taken as the final test of each sample. The charges for polarization testing shall be borne by the Receiver and Deliverer, each party paying his own chemist and one-half the fee of the New York Sugar Trade Laboratory.

(b) For testing for refining quality, samples shall be prepared at the completion of discharge in accordance with the procedure commonly adopted by Receiving Refiners at port of discharge. One (1)

sample shall be forwarded to Deliverer's Laboratory, one (1) to the New York Sugar Trade Laboratory and one (1) to Refiner's Testing Laboratory. Each laboratory shall follow the procedures commonly adopted by Receiving Refiners at port of discharge and shall use the equipment and methods used in the trade for testing the whole raw sugar for moisture, ash, and color, and for testing affined raw sugar prepared from the whole raw sugar for grain size, color, and dextran.

(c) For the purposes of determining whether sugar meets the specifications for standard raw sugar quality and calculating the premiums and discounts specified in Rule 14.13 hereof, an average test result shall be used. Such average shall be determined for each quality specification separately and shall be the average of the two (2) nearest test results of the three (3) laboratories, but if the two (2) are equidistant from the median, then the median shall be used.

Rule 14.12. Polarization Allowances

Allowance per pound for polarization on sugar shall be computed as follows, providing that allowances for fractions of a degree shall be in proportion and that no allowance shall be made for polarization at 99 degrees or higher:

(a) In the case of duty free Sugars, the basis price shall be the contract price; or

(b) In the case of Sugars on which a duty or an import fee is payable, the basis price shall be the contract price, less the applicable duty or import fee per pound on 96 degree sugar in effect on the date of entry of the sugar;

(c) and then apply the following allowances:

(i) For the full degree from 96 degrees to and including 97 degrees add 0.5 percent of the basis price.

(ii) For the full degree from 97 degrees to and including 98 degrees add an additional 2.25 percent of the basis price.

(iii) For the full degree from 98 degrees to, but not including 99 degrees add an additional 1.2 percent of the basis price.

(iv) For the full degree from 96 degrees to and including 95 degrees deduct 5.50 percent of the basis price.

(v) For the full degree from 95 degrees to and including 94 degrees deduct an additional 2.75 percent of the basis price.

Rule 14.13. Variations for Standard Quality

The percentage discount or premium per pound for variances from the specifications set forth in Rule 14.00(b) shall be determined pursuant to the following table, it being understood that discounts and premiums for variances from standard quality shall be applied separately for each specification and that fractions shall be in proportion:

Specification	
Moisture	
Factor of safety	For each .01 in excess of .30 deduct 0.09 percent of basis price.
Ash	
Ash content (Percent of raw sugar)	For each .01 percent of ash content in excess of derived maximum standard ash content deduct 0.015 percent of basis price; for each .01 percent of ash content below derived minimum standard ash content, add 0.00625 percent of basis price.
Grain Size	
Percent through 28 mesh Tyler	For each 1 percent above 52 percent deduct 0.06 percent of basis price. For

(30 mesh U.S.) sieve

each 1 percent below 22 percent add 0.025 percent of basis price.

Color—Affined Raw

I.C.U.M.S.A. Color units
Method 4 (1978) Modified

For each 10 units above 1500 up to and including 1800, deduct 0.0135 percent of basis price. For each 10 units above 1800 up to and including 2100, deduct an additional 0.027 percent of basis price. For each 10 units above 2100 up to and including 2400, deduct an additional 0.0405 percent of basis price. For each 10 units above 2400, deduct an additional 0.0540 percent of basis price.

For each 10 units below 800 add 0.0081 percent of basis price.

Color—Whole Raw

I.C.U.M.S.A. Color Units
Method 4 (1978) Modified*

For each 25 units above 6000 up to and including 7000, deduct 0.0015 percent of basis price. For each 25 units above 7000 up to and including 8000, deduct an additional 0.0030 percent of basis price. For each 25 units above 8000 up to and including 9000, deduct an additional 0.0045 percent of basis price. For each 25 units above 9000, deduct an additional 0.0060 percent of basis price.

For each 25 units below 3000, add 0.0009 percent of basis price.

Dextran **

For each 1 unit above 250 up to and including 350 deduct 0.007 percent of basis price.

For each 1 unit above 350 up to and including 450 deduct an additional 0.009 percent of basis price.

For each 1 unit above 450 up to and including 550 deduct an additional 0.011 percent of basis price.

For each 1 unit above 550 deduct an additional 0.013 percent of basis price.

Deliverer and Receiver may waive any or all of the above adjustments by mutual agreement.

Rule 14.14. Deficiencies or Excesses

The quantity named in the Multiple Delivery Notice shall be the quantity shipped. On outturn the Deliverer is permitted a tolerance of two percent (2%) in excess or deficiency of the quantity shipped.

Rule 14.15. Damage to Sugar

Damage to Sugar after the passage of title in accordance with Rule 14.07 shall not impair delivery. A delivery which is defective because of damage to the Sugar prior to the passage of title shall be deemed to be a default within Rule 14.18.

Rule 14.16. Strikes or Lockouts Affecting Delivery

In the case of strikes or lockouts at delivery port beyond the control of the Receiver or Deliverer which interfere with delivery on the Exchange in accordance with its rules, delivery shall be made, subject to the approval of the Sugar Delivery Committee, on the following basis:

(a) The Receiver shall either (i) subject to final determination, accept whatever responsibility for delays occasioned by such interference, in which case delivery shall be made promptly when the interference is removed, or (ii) designate another Refinery berth in the same port or another port which shall be free of such interference, provided same is permissible under the Charter Party or can be arranged with vessel's owners and further provided any additional costs or expenses shall be for Receiver's account.

* See Sugar No. 14 Resolution No. 1.

** See Sugar No. 14 Resolution No.2.

Rule 14.17. Tax Liability

If any Sugar delivered under Sugar No. 14 Contract is subject to any U.S. Government, State or Local tax, in addition to the Customs duty and import fee referred to in Rule 14.00, the contract shall be interpreted as imposing upon the Receiver to whom the Sugar is delivered the obligation of paying such tax on the Sugar involved in the delivery. An import fee imposed by the United States Government is not a tax within the meaning of this rule and the Receiver shall be under no obligation to pay, except as provided in Rule 14.06(f), or to reimburse the Deliverer for such import fee.

Rule 14.18. Notice of Failure to Meet Obligations

(a) Any dispute arising between Members claiming that a Member has failed to meet his obligations as Deliverer or Receiver under a Sugar No. 14 Contract traded on this Exchange shall be settled by arbitration in accordance with the provisions of this Rule; provided that, if the claimant does not notify the Exchange of such failure within three (3) Business Days of the date on which such Member becomes aware of such failure, said Member shall be deemed to have waived his rights under this paragraph, without prejudice to any other rights or remedies at law or under any other provisions of the By-Laws, rules and regulations of the Exchange.

(b) Upon receipt by the Exchange of the notice of a Member's failure to meet his obligations, the Exchange shall forward one (1) copy of said Notice to all interested parties.

(c) A Special Arbitration Committee of three (3) disinterested members of the Sugar Delivery Committee shall be appointed by the Chairman of the Board within one (1) Business Day of the Exchange's receipt of a notice that a Member has failed to meet his obligations. The Special Arbitration Committee shall establish the date, time and place for a hearing. Each Special Arbitration Committee shall determine the procedures to be followed in any hearing before it, except that the following shall apply in every case:

(i) each of the parties shall be entitled to appear personally at the hearings;

(ii) each of the parties, as this own expense, shall have the right to be represented by counsel in any aspect of the proceeding;

(iii) each of the parties shall be entitled to (1) prepare and present all relevant facts in support of the claims and grievances, defenses or counterclaims which arise out of the transaction or occurrence that is the subject matter of the claim or grievance and does not require for its arbitration the presence of third parties of whom the Exchange cannot acquire jurisdiction and to present rebuttal evidence to such claims or grievances, defenses or counterclaims made by the other parties, (2) examine the other parties, (3) examine any witnesses appearing at the hearing, and (4) examine all relevant documents presented in connection with the claim or grievance, or any defense or counterclaim applicable thereto;

(iv) the formal rules of evidence shall not apply;

(v) no verbatim record shall be made of the proceedings unless requested by a party who shall bear the cost of such record. If such a request is made, a stenographic transcript shall be taken, but not transcribed unless requested by a party who shall bear the cost of such transcription.

(vi) Ex parte contacts by any of the parties with members of the Special Arbitration Committee shall not be permitted.

(vii) The Special Arbitration Committee shall have the power, on the request of the party or on its own motion, to require any Person to testify and/or produce documentary evidence in the proceedings as and to the extent provided for in **Rule 21.04**.

(d) To compensate the aggrieved party for the necessary adjustments in his position, the party adjudged in default shall pay five percent (5%) of the settlement price determined by the Special

Arbitration Committee, or 35/100 (.35) of one cent per pound, whichever shall be greater, to the aggrieved party in addition to the settlements outlined below.

(e) In the case where a Deliverer is determined to be in default by the Special Arbitration Committee for failure to issue a Memo of Deliverer or in delivering the Sugar named in the contract when due then:

(a) where the settlement price (to be the price for Sugar at the place of default, which represents the value of such sugar on the day for which the price is determined) determined by the Special Arbitration Committee is higher than the price stated on the Multiple Delivery Notice, the Deliverer shall be required to pay to the Receiver named on the Multiple Delivery Notice, the difference between the settlement price determined by the Special Arbitration Committee and the price stated on the Multiple Delivery Notice;

(b) where the settlement price determined by the Special Arbitration Committee is lower than the price stated on the Multiple Delivery Notice, the Receiver who received such Multiple Delivery Notice shall be required to pay to the Deliverer the difference between the settlement price determined by the Special Arbitration Committee and the price stated on the Multiple Delivery Notice.

(f) In the case where a Receiver is determined to be in default by the Special Arbitration Committee for failing to meet his obligations as a Receiver of the Sugar named in the contract then:

(i) where the settlement price determined by the Special Arbitration Committee is higher than the price stated on the Multiple Delivery Notice received by such Receiver, the Deliverer named on the Multiple Delivery Notice shall be required to pay to the Receiver the difference between the settlement price as determined by the Special Arbitration Committee and the price stated on the Multiple Delivery Notice;

(ii) where the settlement price determined by the Special Arbitration Committee is lower than the price stated in the Multiple Delivery Notice received by such Receiver, the Receiver shall be required to pay to the Deliverer named on the Multiple Delivery Notice the difference between the settlement price determined by the Special Arbitration Committee and the price stated on the Multiple Delivery Notice.

(g) The Special Arbitration Committee shall render its award in writing adjudging which, if any, party is in default, declaring the settlement price, awarding the amount of money, if any, to be paid by the party in default, and granting any further remedy or relief which it deems just and equitable. The award of the Special Arbitration Committee shall be final and binding upon each of the parties to the arbitration, and judgment upon such award may be entered by any court having jurisdiction. In addition, any award, if not complied with within the time specified in the award, shall be enforceable by disciplinary proceedings pursuant to the Rules.

(h) The payment as prescribed above shall be made by the close of business on the second Business Day after notification in writing of the Special Arbitration Committee's award. Payment and settlement of any default as determined above shall be effected through the President of the Exchange. Such payment shall be accepted as final payment, provided the net amount of any variation Margins which have been paid pursuant to the By-Laws, rules and practices of the Clearing Organization, by either party from the date of issuance of the Multiple Delivery Notice to the date of payment of the settlement of the default, shall be repaid to such party by the other party. Notification of settlement of variation Margins shall be given in writing by the Receiver and Deliverer to the Clearing Organization on the settlement day.

Rule 14.19. Orders Subject to Exchange Rules

All orders given to or received by a Member of the Exchange shall in all respects be subject to and in accordance with, the Rules; and all transactions in Sugar for future delivery shall be in accordance with the Rules and prescribed form of Contract.

Rule 14.20. Clearing Member Open Position Reports to Clearing Organization

(a) All Clearing Members shall report to the Clearing Organization, not later than 9:00 A.M. of each Business Day, the number of purchases and sales executed on the prior Business Day and the number of Sugar contracts which are open on the Members' books for each delivery month at the close of business on such prior Business Day, except that for the Business Day prior to the notice day of any delivery month, said Member shall report with respect to such delivery month no later than 5:00 P.M. that same day.

(b) When the account of any Customer (other than an account carried on an omnibus basis) has a long and short position in the same delivery month, only the net position of the Customer in that delivery month will be reported to the Clearing Organization as open interest.

(c) In the case where a long and short position in the same delivery month is carried by a non-Clearing Member of the Exchange for a Customer, it shall be the responsibility of the Carrying Member to advise the Clearing Member that the long and short position is for the account of the same Customer. In that event, the Clearing Member will not report that position to the Clearing Organization as open interest.

(d) The purpose of this Rule is to enable the Exchange to publish each Business Day the open position in Sugar contracts for each month.

(e) All Members of the Exchange carrying contracts for the accounts of others must act with diligence in reporting and correcting errors in their positions to the Clearing Organization by Clearing Members or to Clearing Members by Carrying Members.

(f) Clearing Members making corrections in their positions with the Clearing Organization, subsequent to the publishing of the daily open positions by the Exchange shall promptly file with the Exchange a statement of the details of such correction, the manner in which the error occurred and, if a Carrying Member be the cause of the error, its name shall be supplied.

Resolutions

No. 1. Color Test Procedures for Sugar: I.C.U.M.S.A. Color Units Method 4 (1978) Modified

RESOLVED, that the color tests for whole raw sugar and affined raw sugar, referred to in the Sugar No. 14 contract, contained at Sugar No. 14 Rule 14.00, and in Sugar Rule 14.13 as I.C.U.M.S.A. Color Units Method 4 (1978) Modified, shall consist of the following procedures:

A. For Whole Raw Sugar:

(1) Prepare a 25% solids solution (25 grams of sample + 75 ml. distilled water) of the sugar to be tested.

(2) Filter the solution through a 47 mm. millipore filter apparatus using a Whatman GF/C 47 mm. glass microfibre filter. Collect the filtrate in a clean dry filter flask. (Note: The sample may require changing the filters more than once to collect all the filtrate.)

(3) Transfer the filtrate to a clean dry 150 ml. beaker. Adjust the pH of the filtrate to $8.5 \pm .1$ with 0.5N HCl or 0.5N NaOH.

(4) Remove entrained air under vacuum or in an ultrasonic cleaner if necessary.

(5) Place the solution into one of a previously matched pair of 1 cm. absorption cells. (The other cell will contain distilled water and can be used as a zero reference when changing wave lengths.) Determine the absorbance (or — log of the transmittance) at 420 nm. and at 720 nm. Record both values.

(6) Calculate the color of the solution as follows:

$$\text{Color} = \frac{(\text{Absorbance * at 420 nm.} - 2 \times \text{absorbance at 720 nm.}) \times 1000}{.2764}$$

If the sample is too dark to analyze, further dilution with distilled water and possible pH readjustment will be needed. In this case the calculation would be as follows:

$$\text{Color} = \frac{(\text{Absorbance * at 420 nm.} - 2 \times \text{absorbance at 720 nm.}) \times 1000}{\text{Specific gravity} \times \text{Brix} \times \text{celllength}} \\ 100$$

* — Log of transmittance can be substituted if there is no absorbance function on the spectrophotometer.

B. For Affined Raw Sugar:

(1) Prepare a 50% solids solution (50 grams of sample + 50 ml. distilled water) of the sugar to be tested.

(2) Filter the solution through a 47 mm. millipore filter apparatus using a Whatman GF/C47 mm. glass microfibre filter. Collect the filtrate in a clean dry filter flask. (Note: The sample may require changing the filters more than once to collect all the filtrate.)

(3) Transfer the filtrate to a clean dry 150 ml. beaker. Adjust the pH of the filtrate to $8.5 \pm .1$ with 0.5N HCl or 0.5N NaOH.

(4) Remove entrained air under vacuum or in an ultrasonic cleaner if necessary.

(5) Place the solution into one of a previously matched pair of 1 cm. absorption cells. (The other cell will contain distilled water and can be used as a zero reference when changing wave lengths.) Determine the absorbance (or — log of the transmittance) at 420 nm. and at 720 nm. Record both values.

(6) Calculate the color of the solution as follows:

$$\text{Color} = \frac{(\text{Absorbance * at 420 nm.} - 2 \times \text{absorbance at 720 nm.}) \times 1000}{.6159}$$

If the sample is too dark to analyze, further dilution with distilled water and possible pH readjustment will be needed. In this case the calculation would be as follows:

$$\text{Color} = \frac{(\text{Absorbance * at 420 nm.} - 2 \times \text{absorbance at 720 nm.}) \times 1000}{\text{Specific gravity} \times \text{Brix} \times \text{celllength}} \\ 100$$

* — Log of transmittance can be substituted if there is no absorbance function on the spectrophotometer.

No. 2. Determination of Dextran

RESOLVED, that the method for the determination of dextran in raw sugar, referred to in the Sugar No. 14 contract, contained at Sugar No. 14 Rule 14.00, and in Sugar Rule 14.13, shall be as follows:

Equipment and Reagents:

(1) Ion exchange resins: Amberlite IR-120 (H) and any one of the following: Duolite A-368, Duolite A-392, Amberlite IRA-93 or Amberlite IRA-68. These resins normally are supplied wet and should be washed with at least twice their weight in distilled water, drained dry, then washed briefly with acetone for no longer than 2 minutes, the solvent being immediately removed, as before. The resins are air-dried or oven-dried at low temperature, approximately 30°C., and stored in a closed container.

(2) Acid-washed Johns Manville Supercel: Supercel (50 ± 5 g.) is added to 1 liter distilled water. Concentrated hydrochloric acid (50 ± 5 ml.) is added and the mixture stirred for 5 minutes. After filtration

the supercel cake is washed with distilled water until the pH of the washings equals that of the distilled water. The Supercel is dried for 6 hours at 100°C. and stored in a closed container.

(3) Trichloroacetic acid J. T. Baker Reagent #1-0414 (TCA): Trichloroacetic acid (10.0 ± 0.1 g.) is dissolved in distilled water and diluted to 100 ml. This reagent will keep for two weeks. (Note: This reagent attacks protein and should not be allowed to come into contact with skin. Do not pipette TCA by mouth nor store it in plastics.)

(4) Starch-removing enzyme: Mycolase enzyme, GB Fermentation Industries, Inc. 1 N. B'Way, Des Plaines, IL 60016. Or α -Amylase type X-A Fungal Crude from *Aspergillus Oryzae*, (Catalog No. A-0273), Sigma Chemical Company, P.O. Box 14508, St. Louis, MO 63178.

(5) Alcohol: Anhydrous, 200 Proof, J. T. Baker Reagent #9401-1.

(6) 25 ml. volume flasks, Corning No. 5660 or equivalent (At the end of each analysis the flasks should be washed with acid-cleaning solution, rinsed with distilled water, and dried for the future use.)

(7) Nessler Tubes, Kimble No. 45310A-100 or equivalent Wash and dry the tubes the same way as described in point #6 above.

(8) Filtering flasks, 1000 ml. size, Pyrex No. 5340 or equivalent.

(9) Burette, 50 ml. size, Pyrex No. 2317 (right hand) or equivalent.

(10) 12.5 ml. Class A volumetric transfer pipette, (custom ordered).

(11) Pipette filler, rubber bulb type or equivalent.

(12) Millipore funnel #XX 1004720 and 0.45 μ M millipore filter #HAWG 047 A0 and absorbent pads.

(13) Vacuum pump with multiple outlet connections for filtration (manifold).

(14) UV-visible spectrophotometer and two matched 5 cm. size cells, and two matched 1 cm. size cells.

(15) Jars, wide mouth, 4 oz. size, flint glass with screw caps.

(16) Hot plate stirrer, Corning PC-351 or equivalent, and stirring bars. Hot plate may be used for incubation providing a water bath is improvised.

Procedure:

(1) Weigh 23.5 g whole raw sugar sample into a wide mouth jar, add 35 ml. of distilled water, insert a magnetic bar, cover and place on a magnetic stirrer to dissolve. (See attached sketch no. 1.)

(2) Add 0.05 g of Mycolase enzyme or α -Amylase to the above sample and incubate at 55°C. for one hour, in an oven or a water bath with agitation every 15 minutes.

(3) Following the incubation add to the sample 5 g of Amberlite IRA-120(H) flint glass with screw caps and 5 g of one of the following: Duolite A-368, Duolite A-392, Amberlite IRA-93 or Amberlite IRA-68 and stir for 30 minutes.

(4) Add 1 g of acid washed Supercel to the sample, mix, and filter through a millipore absorbent pad only into a 100 ml. size Nessler tube placed inside a one liter size filtering flask. Rinse sample jar with approximately 10 ml. of distilled water allowing the washings to go through the funnel into the Nessler tube. Follow this with two small washings of the funnel and contents, taking care not to exceed 100 ml. of total filtrate volume. (See sketch no. 2.)

(5) The sample and washings in the Nessler tube are diluted to the 100 ml. mark with distilled water and then 10 ml. of TCA is added. The Nessler tube is stoppered and shaken.

(6) Filter the above through a $0.45\mu\text{M}$ millipore filter covered with an absorbent pad into a clean Nessler tube inside a one liter size filtering flask, collecting at least 30 ml. of filtrate. (See sketch no. 2.)

(7) Pipette 12.5 ml. of the filtrate into each of the two 25 ml. volumetric flasks, designating the first as the control and the second as the sample, respectively. (Note: use safety pipette filler.) Clean the pipette for the next use by rinsing it with distilled water.

(8) To the first flask ("the control") add distilled water while swirling the flask to the 25 ml. mark, stopper and shake.

(9) To the second flask ("the sample") add anhydrous 200 proof alcohol dropwise (from a 50 ml. size burette) while swirling the flask to the 25 ml. mark. Stopper and mix by inverting the flask gently three to five times. (See sketch no. 3.)

(10) Let the sample stand for 60 ± 2 minutes from the time of completion of the mixing step.

(11) During the above waiting period fill two clean 5 cm size matched cells with distilled water and the control respectively. After zeroing the spectrophotometer at 720 nanometers with the cell containing distilled water, read the absorbance of the control which is designated as B.

(12) Then save the control by pouring it back into its 25 ml. size flask for possible future use. Clean the empty cell by rinsing it several times with distilled water and dry it by rinsing it with acetone.

(13) At the expiration time of the 60 minutes period fill the clean 5 cm. size cell with the sample. After zeroing the spectrophotometer at 720 nm with the cell containing distilled water read the absorbance of the sample which is designated as A. Report results as follows:

$$(A - B) \times 1000$$

When the absorbance of the sample exceeds 0.7 in value both the control and the sample should be reread immediately in 1 cm. size cells respectively. (After zeroing the spectrophotometer at 720 nm with distilled water in a 1 cm. size cell.) Report results as follows:

$$(A - B) \times 5000$$

The results represent dextran content expressed in Milli-Absorbance Units (M.A.U.).

Note:

(1) To achieve reproducible results this procedure must be followed precisely.

(2) Equivalent equipment and/or reagents may be substituted for those specified in this procedure only after comparability with the designated equipment and/or reagents has been demonstrated. This applies particularly to the alcohol reagent.

SKETCH NO. 2

FILTRATION ASSEMBLY

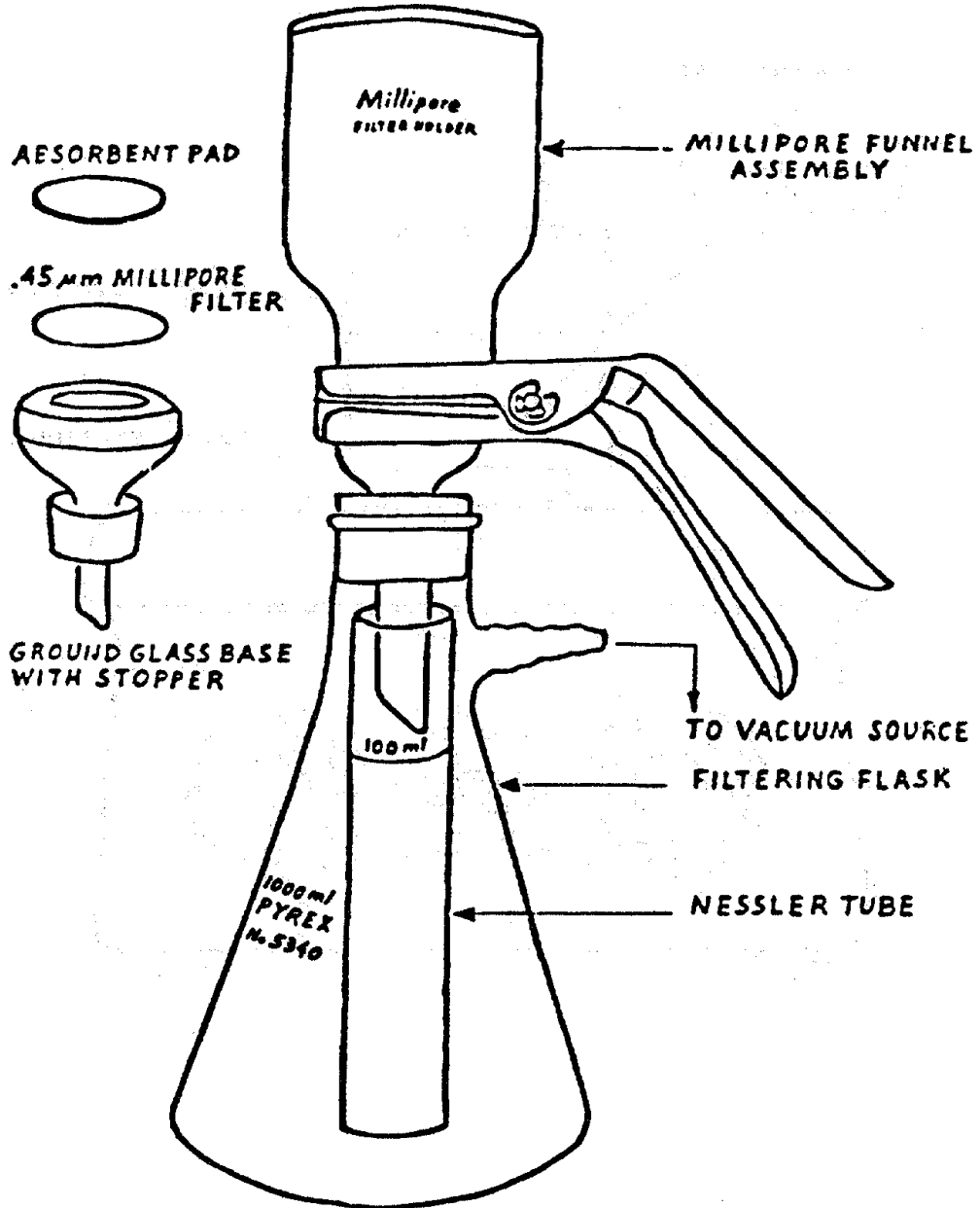

SKETCH NO. 3

ALCOHOL-ADDITION SETUP

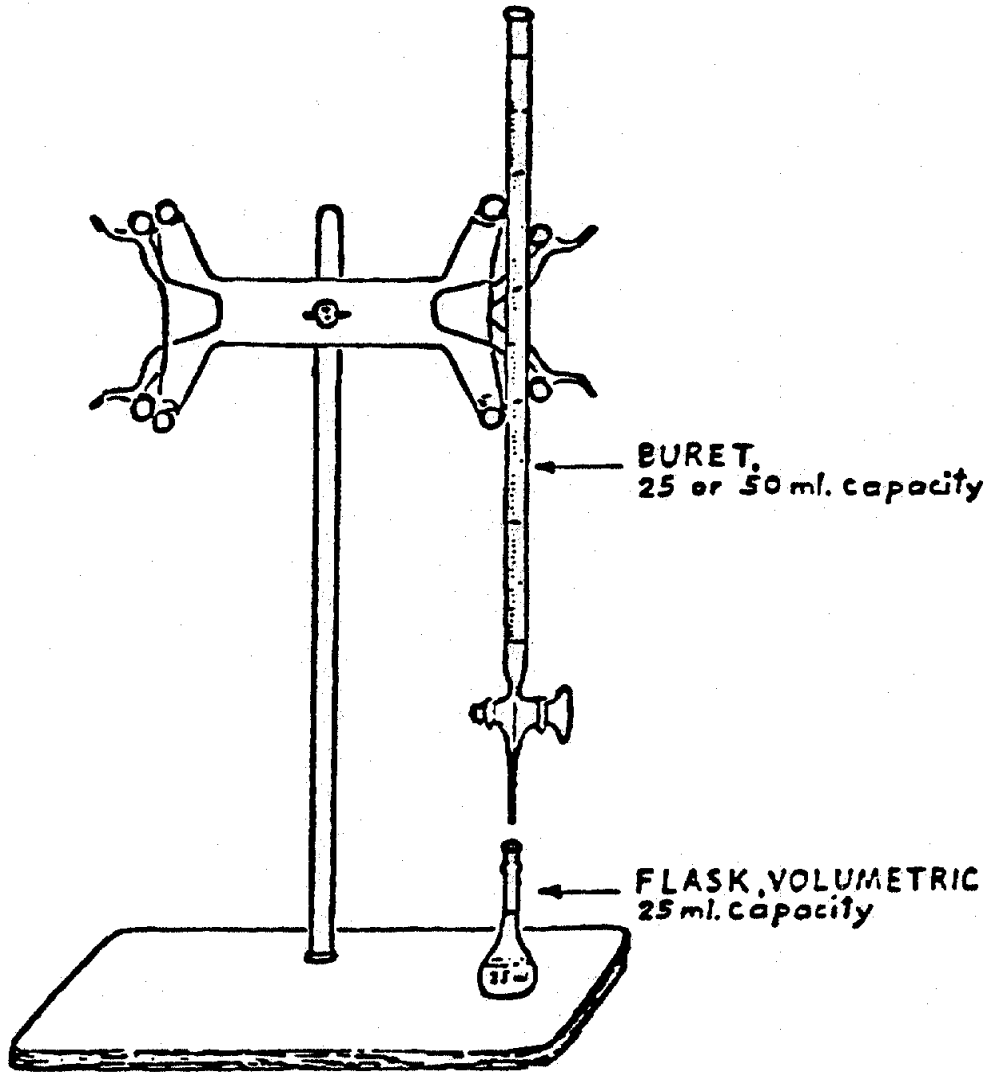

No. 3. Use of Valid Raw Sugar Re-Export Licenses

WHEREAS, Rule 14.00(c) allows for the delivery of foreign growth cane sugars of less than 99.5 degrees polarization, duty and import fee, if any, paid or cane sugars, the product of the United States and its Customs territories; and

WHEREAS, valid raw sugar Re-export Licenses are used routinely by commercial market participants in the domestic sugar market; and

WHEREAS, world sugar imported into the United States in accordance with valid raw sugar Re-export Licenses becomes equivalent to domestically produced sugar; and

WHEREAS, the Domestic Sugar Committee has requested an interpretation as to using sugar brought into the United States pursuant to a valid raw sugar Re-export License for delivery under the Sugar No. 14 futures contract;

NOW, THEREFORE, BE IT RESOLVED, that the Board interprets Rule 14.00(c) to mean that sugar brought into the United States pursuant to a valid raw sugar Re-export License may be used for delivery in the Sugar No. 14 futures contract and that, prior to the Receiver making payment, the Deliverer must provide to the Receiver a copy of the applicable customs form and a letter from a United States Department of Agriculture Licensee stating (i) the quantity of the sugar, (ii) that such sugar is being imported in accordance with its valid raw sugar Re-export License, (iii) the name of the vessel on which the sugar is being imported and (iv) the port in which the vessel will be unloading the sugar.