

LATTICE GAUGE THEORY

Michael Creutz
Brookhaven Lab



Why the lattice?

What drove us to it?

Space-time Lattice

A mathematical trick

World lines \longrightarrow discrete hops

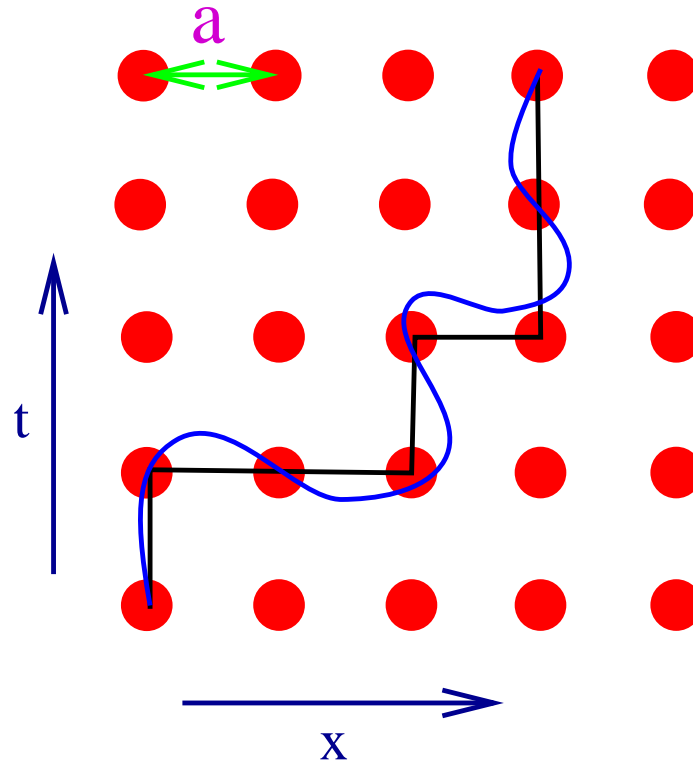

Lattice spacing a
 $a \rightarrow 0$ for physics
 $a = \text{cutoff} = \pi/\Lambda$

What led us to the lattice?

Late 60's

- QED, immensely successful, but “done”
- eightfold way: “quarks”
- electroweak theory emerging
- electron-proton scattering: “partons”

Meson-nucleon field theory failing

- $\frac{g^2}{4\pi} \sim 15$ vs $\frac{e^2}{4\pi} \sim \frac{1}{137}$
- no small parameter

S-matrix theory

- what is elementary?
- particles are bound states of themselves
- $p + \pi \leftrightarrow \Delta$
- $\Delta + \pi \leftrightarrow p$
- roots of duality \longrightarrow string theory

Early 70's

- “partons” \longleftrightarrow “quarks”
- renormalizability of non-Abelian theories
- asymptotic freedom
- Quark Confining Dynamics (QCD) evolving

Confinement?

- interacting hadrons vs. quarks and gluons
- what is elementary?

Flux tubes:

- $E \sim Kr$ at long distances

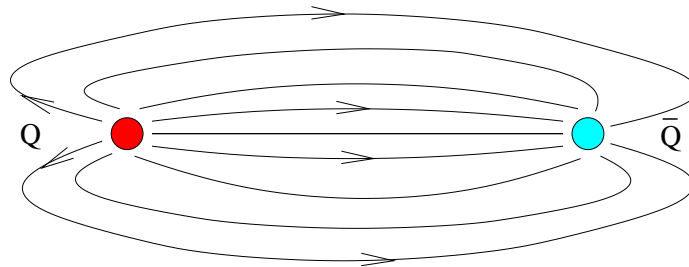

- $K = 14 \text{ tons}$

Mid 70's

- particle theory revolution
- J/ψ
- quarks inescapable
- field theory reborn
- “standard model” evolves

Extended objects

- “classical lumps” a new way to get particles
- bosonization
- connections with statistical mechanics
- what is elementary?

Field Theory >> Feynman Diagrams

Field theory has divergences

- bare charge, mass infinite
- not physical
- must “regulate” for calculation
- Pauli Villars, dimensional regularization
- all based on Feynman diagrams

need a “non-perturbative” regulator

Wilson’s strong coupling lattice theory (1973)

- confines: only hadrons can move
- finite radius of convergence
- Wegner: no local order parameter
- Balian, Drouffe, Itzykson

space-time lattice = non-perturbative cutoff

Lattice gauge theory

- A mathematical trick
- Minimum wavelength = lattice spacing a
- Maximum momentum = π/a
- Allows computations
- Defines a field theory

Lattice gauge theory

- A mathematical trick
 - Minimum wavelength = lattice spacing a
 - Maximum momentum = π/a
 - Allows computations
 - Defines a field theory
-
- Be discrete, do it on the lattice

Lattice gauge theory

- A mathematical trick
 - Minimum wavelength = lattice spacing a
 - Maximum momentum = π/a
 - Allows computations
 - Defines a field theory
-
- Be discrete, do it on the lattice
-
- Be indiscreet, do it continuously

Parameters

$$a \rightarrow 0$$

Asymptotic freedom:

$$g_0^2 \rightarrow 0$$

Overall scale from “dimensional transmutation”

- Coleman and Weinberg

Only the quark masses!

$m_q = 0$: parameter free theory

- $m_\pi = 0$
- m_ρ/m_p determined
- close to reality

Example: strong coupling determined

$$\alpha_s(M_Z) = 0.115 \pm 0.003$$

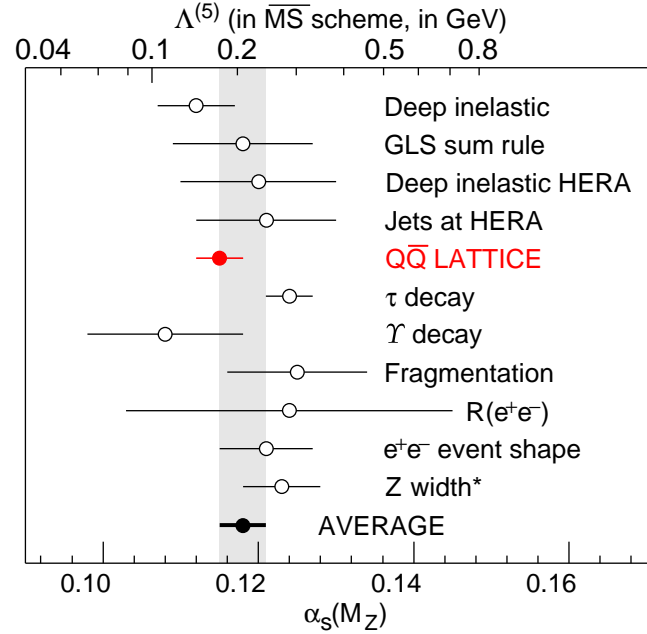

(PDG, 1999)

(charmonium spectrum for input)

Monte Carlo methods

Make random field changes biased by Boltzmann weight.
Converge towards configurations in “thermal equilibrium.”

$$P(C) \sim e^{\beta S}$$

In principle can measure anything.
Fluctuations \rightarrow theorists have error bars!

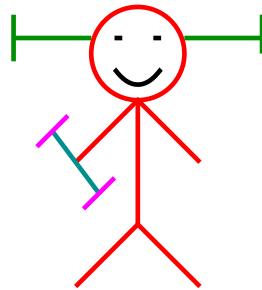

Systematic errors:

- finite volume
- finite lattice spacing
- quark mass extrapolations
- valence approximation for quarks

Interquark force

- constant at large distance
- confinement

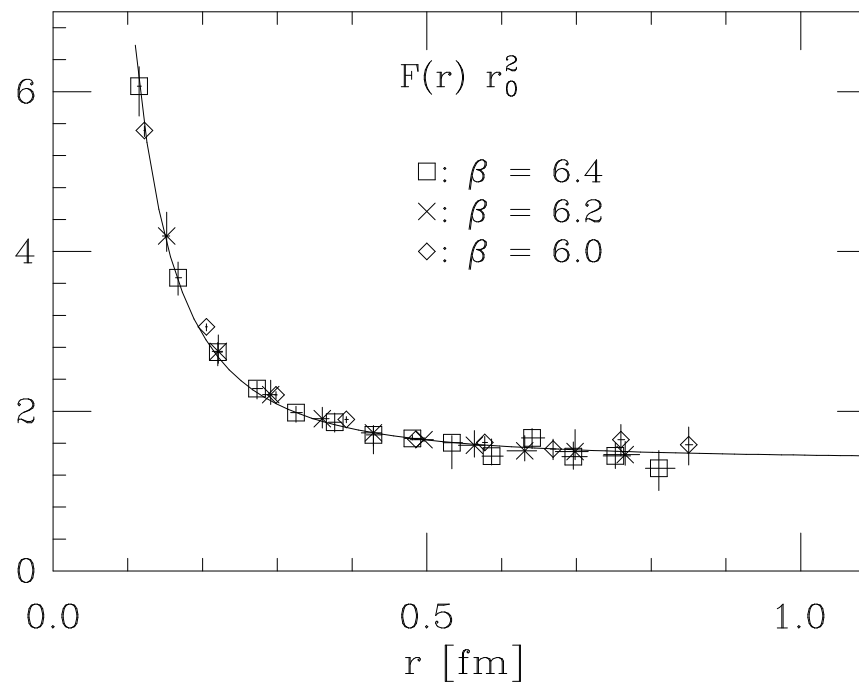

C. Michael, hep-lat/9509090

Quark Gluon Plasma

Finite temporal box of length t

$$Z \sim \text{Tr} e^{-Ht}$$

- $1/t \leftrightarrow$ temperature
- confinement lost at high temperature
- chiral symmetry manifestly restored
- $T_c \sim 235$ MeV, 0 flavors (quenched)
- $T_c \sim 150$ MeV, 2 flavors

Energy ϵ and pressure p versus temperature.

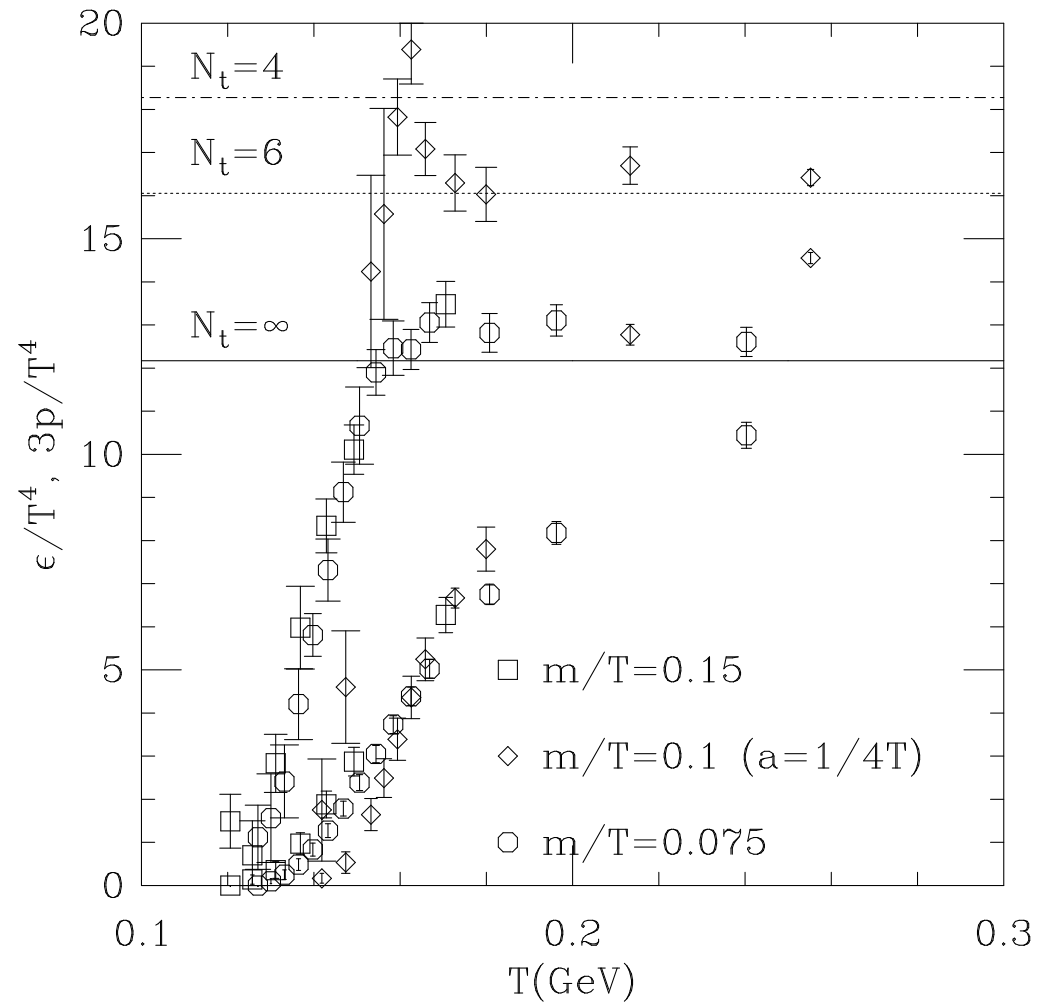

Bernard *et al.*, MILC collaboration, Dec. 1996

Quarks: serious unsolved problems

Anticommuting fields

- \nrightarrow classical statistical mechanics
- Integrate out as a determinant
- Tedious to simulate.

Chemical potential background baryon density

- Non-positive weight.
- **No viable algorithms known!**

Chiral fermions and the “standard model”

- Unsolved difficulties tied with anomalies.
- Lots of recent activity.
- My favorite: **4d world an interface in 5d**

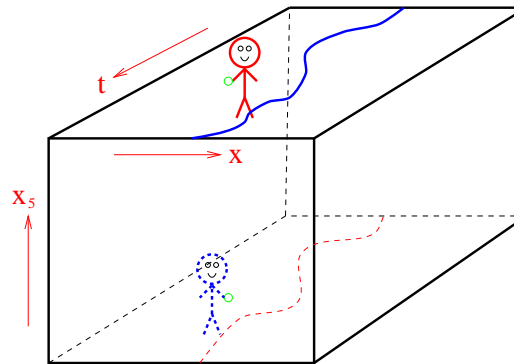

The Lattice SciDAC Project

66 US lattice theorists; 9 member executive committee:

R. Brower, (Boston U.) N. Christ (Columbia U.), M. Creutz (BNL), P. Mackenzie (Fermilab), J. Negele (MIT), C. Rebbi (Boston U.), S. Sharpe (U. Washington), R. Sugar (UCSB) and W. Watson, III (JLab)

Two prong approach

- QCDOC at BNL
- commodity clusters at Fermi Lab and Jefferson Lab
- $\sim 3 \times 10$ Teraflops distributed computing facility

QCDOC

- next generation after QCDSP
- designed by Columbia University with IBM
- on design path to IBM Blue Gene
- Power PC nodes connected in a 6 dimensional torus
- processor/memory/communication on a single chip

Current RIKEN QCDSP machine

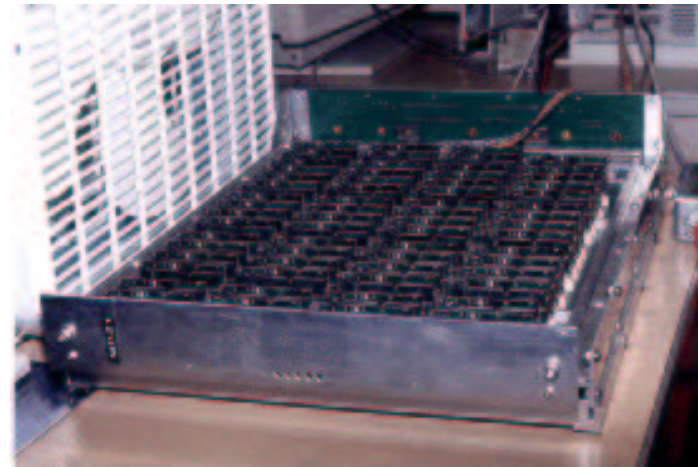

QCDOC places entire node on a single custom chip

QCDOC ASIC DESIGN

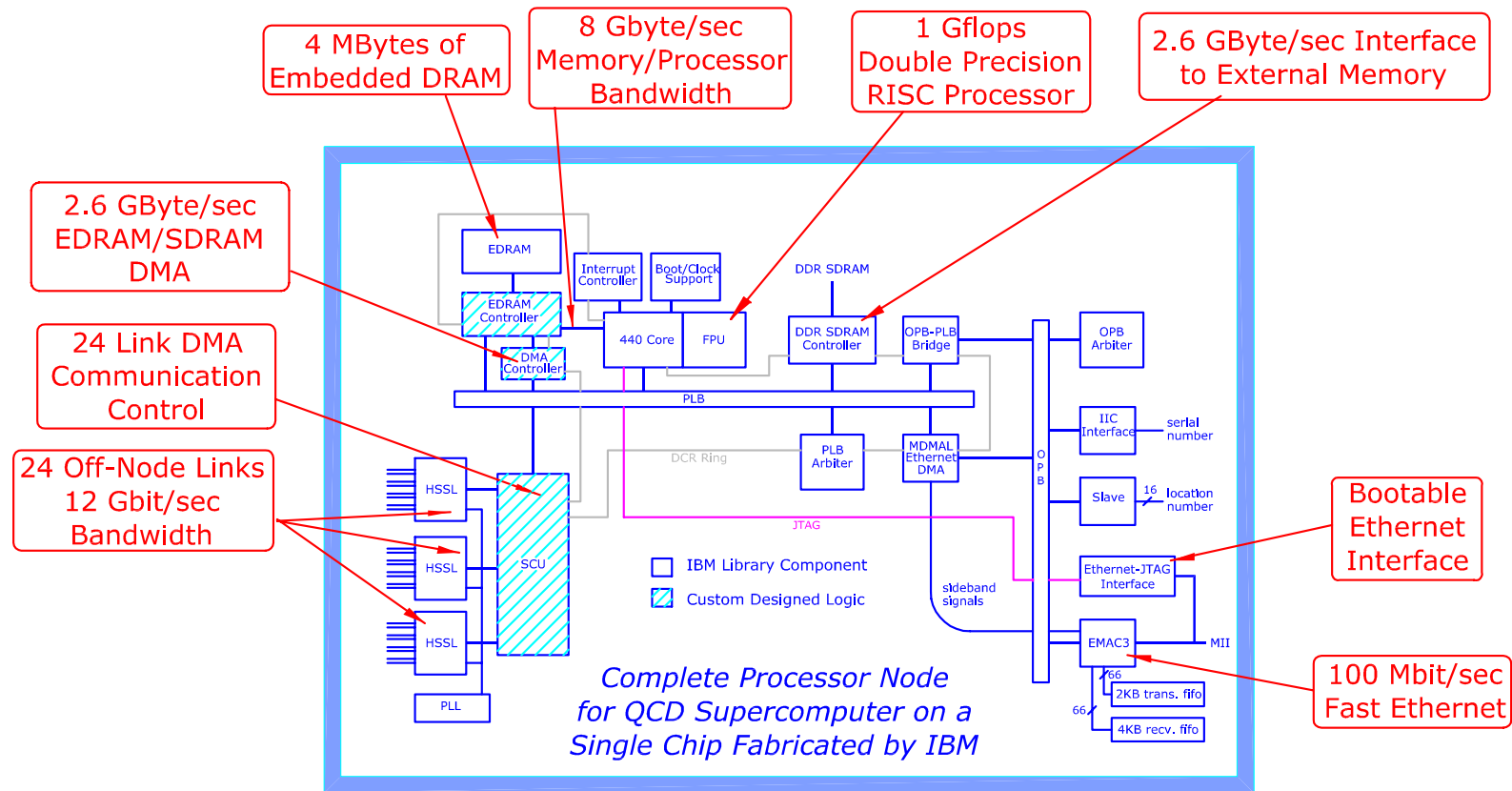

Mission-critical, custom logic (hatched) for high-performance memory access and fast, low-latency off-node communications is combined with standards-based, highly integrated commercial library components.

Approximate schedule

- chip design: done, released to manufacture
- first chips delivered last week
- 128 node prototype at Columbia: early fall
- 1.5 teraflop development machine, at Columbia: end of year
- 10 teraflop sustained BNL machine: 2004
- 5-8 teraflop clusters at JLAB and FNAL: end of 2005

DOE panel review, Feb. 2003

Frank Wilczek (MIT) - chair

Roy Briere (CMU)

David Ceperley (NCSA-UIUC)

Candy Culhane (NSA)

Lynn Kissel (LLNL)

Michael Ogilvie (Washington Univ)

Robert Swendsen (CMU)

Peter Varman (NSF)

“In short, we feel the scientific merit of suggested program is very clearly outstanding.”

My Pet Problems

Chiral symmetry

- parity conserving theories in good shape
- chiral theories (neutrinos) almost there
- finite + gauge invariant + local?
- supersymmetry?

Fermion algorithms

- very awkward
- background “sign problem” unsolved
- why treat fermions and bosons so differently?

We need new ideas!