

ACTIVE GALAXIES EDUCATIONAL UNIT

An Educator's Guide with Activities in Science and Mathematics



National Aeronautics and
Space Administration

<http://glast.sonoma.edu>

ACTIVE GALAXIES EDUCATION UNIT

TABLE OF CONTENTS



| | |
|---|----|
| ● Active Galaxies and the GLAST Education and Public Outreach Program | 2 |
| ● National Standards Matrix | 4 |
| ● Introduction to Active Galaxies | 5 |
| ○ Activity 1: Building Perspectives with Active Galaxies | 6 |
| <i>Student Worksheet:</i> | |
| A Making a Model of an Active Galaxy | 9 |
| B Drawing the Active Galaxy Model from Different Perspectives | 10 |
| ○ Activity 2: Zooming In on Active Galaxies | 11 |
| <i>Student Worksheet:</i> | |
| A Testing the Small Angle Approximation | 17 |
| B Measuring the Angular Size of a Person | 18 |
| C Measuring the Angular Size of a Galaxy Using the Active Galaxies Poster | 20 |
| ○ Activity 3: Light Travel Time and the Size of Active Galaxies | 22 |
| <i>Student Worksheet:</i> | |
| A Finding the Size of an Active Galaxy Flare Region | 26 |
| B Measuring the Size of an Active Galaxy Flare Region .. | 26 |
| C Measuring the Energy Emitted by an Active Galaxy Flare | 28 |
| ● Glossary (Definitions and Acronyms)..... | 29 |
| ● Detailed Standards for Each Activity | 31 |
| ● Resources | 34 |
| ● Educator Reply Card | 36 |



ACTIVE GALAXIES AND THE GLAST EDUCATION AND PUBLIC OUTREACH PROGRAM

Busy educators sometimes have trouble finding ways to help their students feel the excitement of science in action. As a part of its educational effort, the NASA Education and Public Outreach group at Sonoma State University (SSU) has put together a series of activities presentation based on the science of one of NASA's exciting space missions: the Gamma-ray Large Area Space Telescope (GLAST).

Since many students remember and understand better when they actively engage in manipulating the concepts about which they are learning, we have included several hands-on activities to help keep their interest and reinforce their comprehension and retention of the scientific concepts covered in the presentation of the mission. We have also included information about GLAST, what kind of objects it will observe and why astronomers are interested in them. To help you determine when this project might be of most use to you in your science and/or math curriculum, we have included a matrix of the math and science standards covered. This introduction to the activities includes the answers to some frequently asked questions.

What is GLAST?

The Gamma-ray Large Area Space Telescope (GLAST) is a NASA satellite planned for launch in 2006. GLAST is part of NASA's Structure and Evolution of the Universe theme. The astronomical satellites in this theme are designed to explore the structure of the Universe, examine its cycles of matter and energy, and peer into the ultimate limits of gravity: black holes. GLAST detects gamma rays, the highest energy light in the electromagnetic spectrum. GLAST is being built in collaboration between NASA, the U.S. Department of Energy, France, Germany, Italy, Japan, and Sweden. The project is managed from NASA's Goddard Space Flight Center in Greenbelt, Maryland.

Where do gamma rays come from?

Gamma ray sources include black holes, pulsars, supernova remnants, and active galaxies. Active galaxies will be a very common source of high-energy gamma rays detected by GLAST. Thousands of these sources will be studied during its mission.

What instruments will GLAST use?

There are two scientific instruments on board GLAST: the Large Area Telescope (LAT) and the GLAST Burst Monitor (GBM). The LAT is the primary instrument, and will survey the sky in high-energy gamma-ray light. It will also study many individual sources of gamma rays. The GBM will detect Gamma Ray Bursts, tremendous explosions coming from vast distances. These explosions are thought to signal the birth of black holes.

What will my students learn from these activities?

This series of activities uses active galaxies – distant galaxies with supermassive black holes in their cores – as an engagement to teach basic concepts in physical science and mathematics. The mapping of the activities to the relevant national standards is shown by the matrix on page 4, and a more detailed listing of the standards met by each activity can be found in pages 31 through 33.

How are these activities organized?

Page 5 has a general introduction to active galaxies. Depending on the age and ability of your students, you may need to tell them about this information, have them read it, or have a few advanced students put together a presentation to the rest of the class based on this introduction and other sources they may find. With this introduction, try to convey the excitement of the scientists when they first discovered interesting phenomena related to active galaxies, such as the supermassive black holes at their cores, and the high-energy jets of particles that are sometimes emitted.

Each activity has some or all of the following components to help you make it an exciting learning experience for the students:

1) Science concepts and estimated time. (Note: time varies significantly for different age groups and levels of science understanding.)

2) Background information specific to this activity. (See the suggestions above for possible ways to present this background information.)

3) The “essential question” asked by the activity. Take the time to help students understand that scientists ask questions. Each activity states the essential question that this activity is designed to answer, or to help the student explore.

4) The materials needed to complete the activity.

5) A list of abbreviations used and possible additional notes to the teacher.

6) The specific learning objectives of this activity.

7) The step-by-step procedures to be followed for the most efficient and effective use of the activity.

8) An assessment rubric for the activity. It is important that before you start an activity you have a clear understanding of what constitutes a successful activity. This assessment rubric suggests ways to evaluate your students’ work in mastering the activities’ objectives.

9) Transfer activities: One of our goals in science is to help students see science and scientific concepts as tools to be used throughout their lives, not just as a small part of their education. Including transfer activities *after* the activity is completed will not only reinforce the specific objectives, but also help your students learn to apply scientific concepts to their “real lives.”

10) Suggested extension and reflection activities. These help the student follow up the activity with comprehension exercises so that they better assimilate the information, and use the concepts they have learned to better understand phenomena in everyday life.

11) Lesson adaptations that will help you cope with special needs students.

12) An answer key that provides you with the answers to the questions given to the students, and that will help you evaluate the products the students may produce as a part of this activity.

13) Student worksheets that contain the information and directions necessary for the student to complete the activities. NOTE: giving the students the work sheet without the appropriate background information and procedures will not only decrease the learning of the students, it may also cause frustration and feelings of inadequacy to master science principles.

14) Detailed Standards list that explains how each activity meets the specific national science and mathematics standards.

15) A glossary that briefly defines each term with which the student may be unfamiliar (these appear in **bold** letters the first time they are used in the activity).

16) A list defining any acronyms used.

17) A resource list which will help you find more information about the topics in the activities.

Who developed these activities?

The activities and the poster that describes active galaxies have been developed as part of the NASA Education and Public Outreach (E/PO) Program at Sonoma State University, under the direction of Professor Lynn Cominsky. The poster is available by request at <http://glast.sonoma.edu/teachers/teachers.html>

Contributors to this education unit also include Dr. Philip Plait, Lynda Williams, Sarah Silva, Michelle Curtis, Aurore Simonnet, Tim Graves, and Dr. Mary Garrett. We would also like to acknowledge input from Kara Granger and Dr. Laura Whitlock to an earlier version of the first activity, and helpful comments from Sharon Janulaw, Teena Della, Christine Royce, Dr. William Keel, Dr. Greg Madejski, Tom Arnold, Rae McEntyre, Bruce Hemp, and Tom Estill.



NATIONAL CONTENT STANDARDS MATRIX

The activities in this booklet conform to these national science and mathematics education standards. Detailed standards met by each activity are listed pages 31-33.

| Content Standard | Science Standards | | | | | Math Standards | | | | |
|--|-------------------------|-----------------------|------------------------------|-----------------------------|------------------------------------|-----------------------|---------|----------|--------------|-------------------------------|
| | A Science as Inquiry | B Physical Science | D Earth and Space Science | E Science and Technology | G History and Nature of Science | Number and Operations | Algebra | Geometry | Measurements | Data Analysis and Probability |
| Building Perspectives with Active Galaxies | | | ✓ | ✓ | ✓ | | ✓ | ✓ | ✓ | |
| Zooming In on Active Galaxies | ✓ | ✓ | ✓ | ✓ | ✓ | ✓ | ✓ | ✓ | ✓ | |
| Light Travel Time and the Size of ActiveGalaxies | ✓ | ✓ | ✓ | ✓ | ✓ | ✓ | ✓ | | ✓ | ✓ |

INTRODUCTION TO ACTIVE GALAXIES



A **galaxy** is a system of stars, gas, and dust bound together by their mutual gravity. A typical galaxy has billions of stars, and some have trillions. Although they come in many different shapes, the basic structure is the same: a dense core of stars called a 'nucleus' surrounded by stars and gas. Normally, the core of a disk or elliptical galaxy is small, relatively faint, and composed of older, redder stars. However, in some galaxies the core is intensely bright, shining with power equivalent to trillions of suns, easily outshining the rest of the light of the galaxy combined. A galaxy that emits such tremendous amounts of energy is called an **active galaxy**, or **AG** for short. Active galaxies are actually rare, but so bright they can be seen clear across the visible universe.

It is believed that at the center of these bright galaxies lies a supermassive **black hole** millions or even billions of times the mass of our Sun (Figure 1). As matter falls toward the black hole, it forms an **accretion disk**, a flattened disk of material swirling around the black hole. Friction and magnetic forces inside the disk heat it to millions of degrees, and it glows brightly nearly all the way across the electromagnetic spectrum, from radio waves up to X-rays. Although our own Milky Way Galaxy has a central supermassive black hole, it is not an active galaxy. For reasons currently unknown, the black hole at the center of our Galaxy is **quiescent**, or inactive, as are most present-day galaxies.

Although the physics underlying the phenomenon is not well-understood, it is known that in some cases the accretion disk focuses long **jets** of matter which streak away

from the core at speeds near that of light. The jets are highly collimated (meaning they retain their narrow focus over vast distances) and are emitted in a direction perpendicular to the disk. Eventually, they slow to a stop due to friction with gas well outside the galaxy, forming giant clouds of matter that radiate strongly at radio wavelengths (**radio lobes**; Figure 2). In addition, surrounding the accretion disk is a **torus** (donut) of molecular material. From certain viewing angles, this torus can obscure observations of the black hole and accretion disk.

There are many types of active galaxies. Initially, when astronomers were first studying them, it was thought that the different types of AGs were fundamentally different objects. Now astronomers generally (but not universally) accept the *unified model* of AGs, meaning that most or all AGs are actually just different versions of the same object. Many of the apparent differences between types of AGs are due to

viewing the AG at different orientations with respect to the disk, or due to observing the AG in different wavelengths of light.

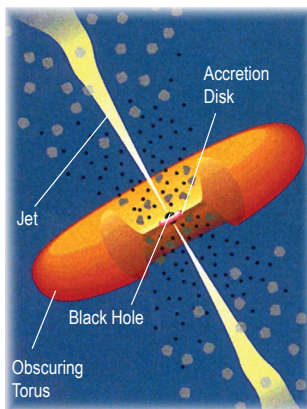
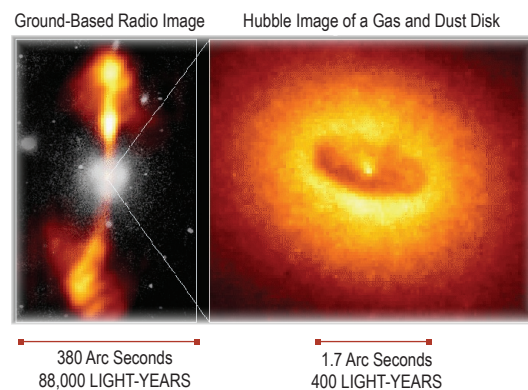

Fig. 1 Artist's illustration of an active galaxy

Fig. 2 Double-lobed radio galaxy NGC4261





ACTIVITY 1: BUILDING PERSPECTIVES WITH ACTIVE GALAXIES



Science Concepts: • *There are different components in active galaxies.*
• *Different viewing angles lead to dramatic differences in the appearance of simple objects.*

Duration:
60 minutes

Background Information:

The type of active galaxy we see depends on the way that we see it. If we see the accretion disk and gas torus edge on, the galaxy is called a **radio galaxy**. The torus of cool gas and dust blocks most of the radiation from the inner black hole and its nearby environment, so the most obvious features are the radio emitting jets and giant lobes well outside the galaxy.

If the disk is tipped slightly to our line of sight, we can see higher-energy light from the accretion disk inside the gas torus in addition to the lower energy radio waves. This kind of AG is called a **Seyfert galaxy** (named after American astronomer Carl Seyfert, who first catalogued these galaxies in 1943). It looks much like a normal galaxy but with a very bright core, and may be giving off high-energy photons like X-rays. If the galaxy is very far away from us, we may see the core as a star-like object even if the fainter surrounding galaxy is undetected. In this case, the galaxy is called a **quasar**, which is short for quasi-stellar radio source (so-named because the first ones discovered appeared to be star-like through a telescope, but emitted copious radio waves, unlike “normal” stars). The first quasar to be discovered, dubbed 3C273, was found to be a galaxy at a very large distance by astronomer Martin Schmidt in 1963.

Essential Question:
What do active galaxies look like when viewed from different directions?

If the tip angle is 90 **degrees**, we can be looking straight down a jet. This type of active galaxy is called a **blazar**. From blazars we see very high-energy gamma ray **photons**. The first blazar to be discovered, BL Lac (and after which we get the term “blazar”) was found in 1926 to change in brightness, but was thought to be a normal star!

It wasn’t until the late 1970s that its galactic nature was truly revealed.

In sum, the basic components of an active galaxy are: a supermassive black hole core, an accretion disk surrounding it, and a torus of gas and dust, and in some (but not all!) highly focused jets of matter and energy. The type of active galaxy we see depends on the way we see the galaxy: radio galaxies, Seyferts, quasars and blazars.

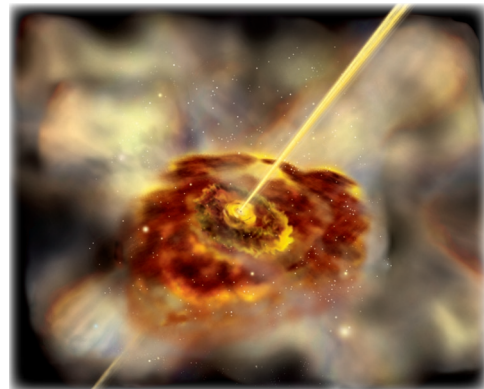

Fig. 3 Artist's illustration of an active galaxy



Materials for each group of 2 or 3 students:

- Styrofoam ball (1.5 inch or 4 cm in diameter)
- 2 toothpicks
- 1 lightweight sheet of construction paper
- 1 heavier weight sheet of construction paper
- 3 pages of blank or bond white paper
- scissors
- compass
- ruler
- cellophane tape
- colored pencils or pens



Objective:

Students will build a model of an active galaxy. From this, they will learn about the geometry of the components of the galaxy and understand that different viewing angles lead to dramatically different appearances of the galaxies.

Procedure:

1. Introduce the activity by using the information in the *Introduction to Active Galaxies* (page 5) and in the activity *Background Information* (page 6).

2. Discuss these questions with the students before starting the activity:

Do objects look the same from all angles? Are they recognizable from all angles? For example, it's not difficult to recognize a book from almost any viewing angle. But is every object like that? How do we recognize objects if viewed from unfamiliar angles? How do we categorize unfamiliar objects if seen from different angles?

3. Explain to the students that they will be building a model of an active galaxy from a styrofoam ball, construction paper, toothpicks and tape. This model will help them answer the questions on the worksheet. The model building can be done in groups of two or three.

4. Have the students make observations of the model, then sketch them as viewed from different angles. This should be done individually.



Assessment: The students' work can be assessed using the following rubric:

| | |
|--|--|
| <p>4 Points</p> <ul style="list-style-type: none"> → All calculations are correct → Model is assembled correctly and neatly → Drawings are complete and neatly done → Description of different views are accurate | <p>2 Points</p> <ul style="list-style-type: none"> → Two calculations are incorrect, or two drawings drawn/labeled incorrectly, or model built incorrectly, or two descriptions are incorrect, or some combination |
| <p>3 Points</p> <ul style="list-style-type: none"> → One calculation is incorrect, or one drawing is drawn/labeled incorrectly, or one description is incorrect | <p>1 Point</p> <ul style="list-style-type: none"> → Drawings or descriptions are incorrect |
| | <p>0 Points</p> <ul style="list-style-type: none"> → No work turned in |

Extension Activities:

Compare and contrast the students' drawings to those on the GLAST Active Galaxies Poster for the different viewing angles. Discuss how this activity changes their perspectives about how they view and interpret what they see in the Universe.

Transfer Activities:

Have the students examine and draw everyday objects from different angles. Pass the drawings around to other students and see if they can identify the object, especially if the viewing angle is unfamiliar.

Lesson Adaptations:

Visually impaired students may have difficulty constructing the models and drawing them. Put the model in their hands, and let them note by touch how the model feels different if they can only access one part of it at a time (for example, a single cone/jet). They can examine how the model feels different if they keep their hand flat, fingers extended, and can only touch the model that way. In that example, the opening of the cone will feel like a circle, and the torus will feel flat. Have them describe how limiting their ability to touch the model limits their ability to identify its parts.



Answer Key for “Building Perspectives with Active Galaxies”

- 1) 1.5 inches or 4 cm
- 2) If the conical paper jet is properly constructed, it will obscure the styrofoam ball (black hole).
- 3) For a 4 cm diameter styrofoam ball, the minimum width of the strip should be 4 cm (1.5 inches).
- 4) The torus length should be 10 cm times $2\pi = 62.8$ cm.
- 5) This answer will depend on the student. In general, looking straight down the jets will hide the black hole, accretion disk and torus. From an angle, the black hole, accretion, disk and torus will be visible, and the jets will be elongated. The far jet may be difficult to see. From the side, the black hole and accretion disk are again hidden, this time by the torus. Both jets will be visible and about the same size.

ACTIVITY 1: STUDENT WORKSHEET



A. Making a Model of an Active Galaxy

The styrofoam ball represents the black hole at the center of the active galaxy. In the next few steps, you are going to make an accretion disk, cones that represent the jets of the active galaxy, and the torus that surrounds the accretion disk.

1. Accretion Disk: Measure the diameter of your ball, just to be sure of the size. Note the size both in inches and centimeters here (1 in = 2.54 cm)



Question 1: Diameter: _____ (in)
 _____ (cm)

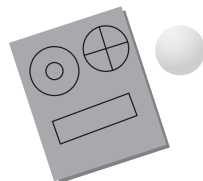

1. What you need



2. Cut out annular disk inner circle

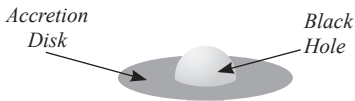

3. Assemble annular disk and styrofoam ball

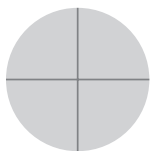

4. 20 cm circle

With your compass, draw a circle with the diameter of your styrofoam ball on the heavier weight construction paper. Using the same center, draw a concentric circle with twice the diameter. Cut the large circle and then cut out the inner circle to make an **annular** disk (a ring with a hole in the center). Gently work the styrofoam ball through the inner circle of your annular disk until it is exactly in the middle. This is your accretion disk! You can draw a swirling vortex on it and label “accretion disk” or other appropriate descriptive words that describe the properties of the disk.

2. Jets: With your compass, draw a circle 20 cm in diameter on the lightweight construction paper. With your ruler, draw 2 perpendicular lines through the center as shown. Cut the circle out and cut it in half. Each semicircle will be rolled into a cone to make a jet. Hold the half circle so that the drawn line is on the inside of the cone. Curl up the inner edge of the paper to the drawn line to make your cone. Tape the outside edge.

Make sure the **apex** of your cone is nice and tight so you can stick it to the styrofoam ball with a toothpick. When you have made both jets, attach them to the styrofoam ball by piercing the apex with a toothpick and sticking the cones symmetrically on the ball above and below the accretion disk.



5. Cut the circle in half



6. Roll it into a cone



7. Tape the edge to form a cone



8. Attach the cones to the styrofoam ball

Name: _____ Period: _____ Date: _____

Question 2: Look down a jet. Does it obscure the black hole?

Question 3: Using the diameter of your styrofoam black hole ball you measured above, what is the minimum height your torus strip of paper should be?

TORUS HEIGHT: _____ (in)
_____ (cm)

Question 4: What should the length of your torus strip of paper be so that it will exactly wrap around the accretion disk? In other words, what is the circumference of your accretion disk? (circumference of a circle = $2\pi r$)

TORUS LENGTH: _____ (in)
_____ (cm)

3. Torus:

Using your ruler, mark the dimensions of your torus strip on the lightweight construction paper and cut it out. Color and label the strip with descriptive terms and then wrap it around the accretion disk so that it has equal height above and below the plane of the disk. When viewed edge on, the torus should obscure the accretion disk and the black hole. Attach it to the accretion disk with tape.

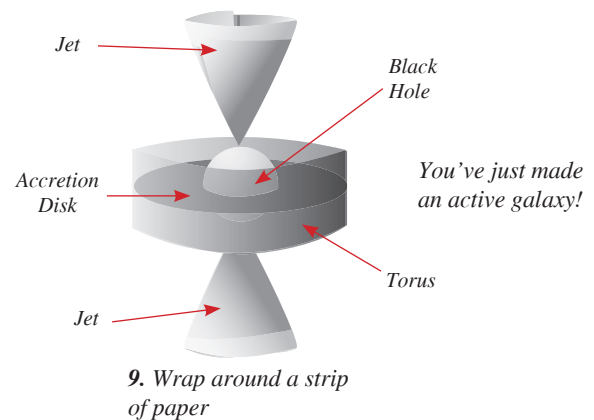

B. Drawing the Active Galaxy Model from Different Perspectives

View your active galaxy model from the following three views:

1. Down a jet
2. At an angle to the jet (not 90 degrees!)
3. 90 degrees from the jet

Question 5: On separate pieces of paper, sketch what you see from those three angles. Describe how they are alike and how they are different.

Attach your drawings to this worksheet before you hand in your work.

ACTIVITY 2: ZOOMING IN ON ACTIVE GALAXIES



Science Concepts: • *The small angle approximation has limits.*
• *The angular size of an object depends on its distance and its physical diameter.*

Duration:
45 minutes

Background Information

The appearance of a distant object and the amount of detail we can see in it is directly related to how far away it is from us - the closer an object is, the larger it appears and the easier it is to see details; the farther away it is, the smaller it appears and the harder it is to see details.

Although active galaxies are often hundreds of thousands of **light years** in size, their great distances make them challenging to observe in detail. In this activity we explore how the distance to an active galaxy affects how we see it.

Let's imagine distance is not a factor and take a fantasy flight into a cartoon active galaxy (AG) that has jets. The long view of the AG is dominated by lobes of radio emission caused by highly focused twin jets of matter streaming out from the galactic nucleus (Figure 4). Closer in, a torus of dust and gas can be seen orbiting outside a flatter disk of gas (Figure 5). In an extreme close-up, the invisible black hole in the center is surrounded by a flat accretion disk of rapidly orbiting material. Jets are emitted at right angles from the plane of the disk, driven by physics still not well understood (Figure 6).

Now let's consider a real AG: the double-lobed radio galaxy NGC 4261, which is located approximately 100 million light years from Earth. The Hubble Space Telescope and ground-based radio images (Figure 1, on page 5) of NGC 4261 shows radio lobes that span some 100,000 light

years out from a spiral-shaped disk of gas and dust 400 light years in diameter. Presumably, a small but supermassive black hole "engine" lies at the center of the nucleus with a mass 1.2 billion times the mass of the Sun and contained in a space about the size of the solar system - about 6 billion kilometers. Imagine that!

How much detail can we actually see with the Hubble Space Telescope (HST) in a galaxy 100 million light years away?

The smallest objects HST can discern have an angle of about 0.1 arcseconds (about 0.00005 times the width of the full Moon). Using the *small angle formula* (see activity on page 12) this angular diameter translates into a linear size of 460 trillion kilometers at the distance of NGC 4261! This is over 100,000 times larger than the effective size of the black hole. That's why we can't directly see the black hole at the core of the galaxy. Rather, we infer the existence and the properties of the black hole indirectly by observing the effect it has on the gas and stars surrounding it.

The GLAST observatory, designed to detect gamma rays from active galaxies, will have a resolution of roughly 0.5 **arcminutes** (about 1/60th the width of the full Moon). Although no current detection technology exists that can see the central black hole in an active galaxy, GLAST will be able to detect gamma rays produced by the jets with unprecedented sensitivity. Such data will help us understand the physical processes that are going on in the nucleus and the supermassive black hole engine that fuels it.

Essential Question: What do active galaxies look like when viewed from different distances?

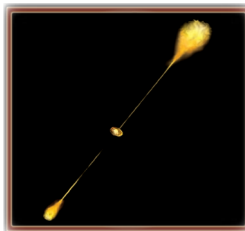

Fig. 4 Active Galaxy seen at a great distance

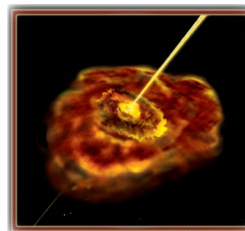

Fig. 5 Zooming in on the Active Galaxy

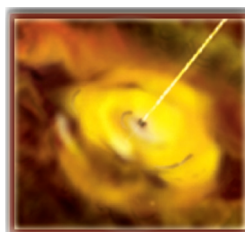

Fig. 6 Zooming in to see the central torus

Additional Background:

We imagine the sky to look like a giant hollow sphere surrounding the Earth. It really isn't, but real objects are so far away that we have no real perception of distance, and so when we look at stars in the sky our brain interprets them as being infinitely far away. This gives the sky an illusion of being a hollow sphere with us at the center.

When astronomers measure the size of objects in the sky or the distance between them, they use **angular size**. A circle drawn all the way around the sky is divided into 360 degrees, so two objects on opposite sides of the sky are said to be 180 degrees apart. An object that spans $\frac{1}{4}$ of the sky's circumference would be 90 degrees across, and so on. The disk of the Moon in these units has an angular diameter of 0.5 degrees. Degrees are further subdivided into 60 arcminutes (the term "arc" is to help distinguish this from a measure of time, and the unit is abbreviated as a single tick mark: ') and each arcminute is further divided into 60 arcseconds (abbreviated with a double tick mark: "). The Moon can thus be described as having an angular diameter of 30 arcminutes, or 1800 arcseconds. Most distant astronomical objects such as galaxies are fractions of an arcsecond to a few arcminutes in angular extent.

The relationship between angular diameter, distance, and appearance is shown below: the closer an object is, the larger the angle it covers and the larger it appears; the farther away an object is, the smaller the angle it covers and the smaller it appears.

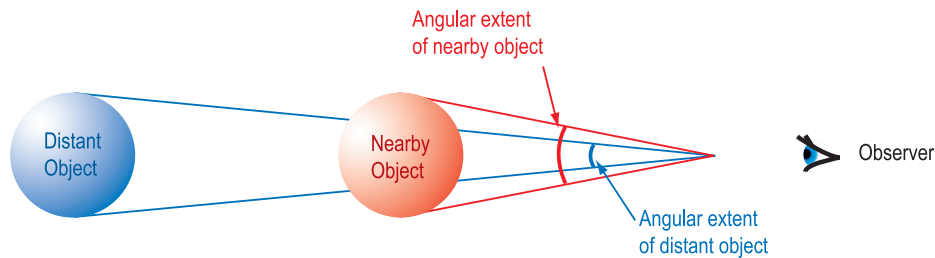

Mathematically, angular diameter, linear diameter, and distance can be combined in an extremely useful and simple equation called the **small angle approximation**. As seen in the figure below, the angular diameter, α , depends on the distance to the object, D , and its actual linear diameter, d , according to:

$$\tan(\alpha/2) = d / 2D$$

The students will show in this part of the unit, for very small values of α measured in **radians**, $\tan(\alpha) = \alpha$. Using this approximation, the equation relating distance and linear size simplifies further to

$$\alpha/2 = d / 2D \quad \text{or more simply} \quad \alpha = d/D$$

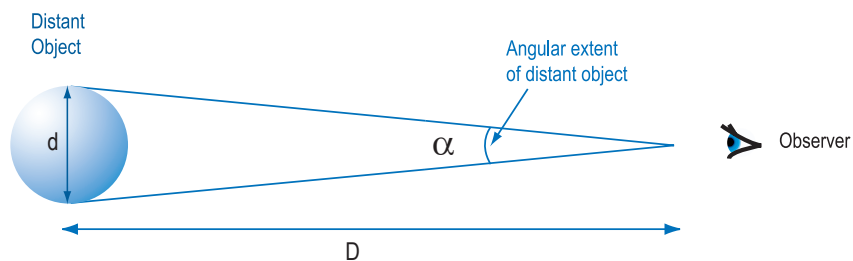

In the small angle approximation, if any two of the quantities are known, the third can be calculated. In astronomy, the angular diameter is usually measured directly and the equation is used to calculate the distance or the physical diameter of the object. Since distances to astronomical objects are usually much larger than their linear sizes, this approximation is of great use in all branches and at all levels of astronomy!

The following table provides a summary of the unit conversions discussed above, along with some other abbreviations that will be used later in the unit. It may be useful for your students to have access to this table.

| Abbreviations: | Conversion Factors: |
|---------------------------|--|
| α angular diameter | <i>Light year to meters:</i> $1 \text{ ly} = 9.5 \times 10^{15} \text{ m}$ |
| cm centimeters | <i>Meters to centimeters:</i> $1 \text{ m} = 100 \text{ cm}$ |
| $^{\circ}$ degrees | <i>Kilometers to meters:</i> $1 \text{ km} = 1000 \text{ m}$ |
| d diameter | <i>Radians to degrees:</i> $1 \text{ rad} \times \frac{180^{\circ}}{\pi \text{ rad}} = 57.3^{\circ}$ |
| D distance | |
| ly light year | |
| m meters | |
| mm millimeters | |
| % percentage | |
| rad radian | |
| s second | |

Note for the teacher: Just like with hands, some people are right-eyed and others left-eyed. The instructions for the template construction below assume the student will be using their right eye. When the students are constructing the template, they can reverse left and right in the directions if they prefer to use their left eye.



Materials for each group of 3 students:

- GLAST Active Galaxies Poster
- protractor
- stiff cardboard
- meter stick or tape measure
- pencil
- scissors or knife
- calculator



Objectives:

Students will be able to accurately use and understand the small angle formula, and demonstrate this by filling out a table.

Students will be able to construct a template and use it to correctly measure the angular size of a person.

Students will be able to use the Active Galaxies Poster to measure the angular size of a galaxy.

Procedure:

1. Introduce the activity by reviewing the information in the *Introduction to Active Galaxies* (page 5) and the activity *Background Information* (page 11).
2. Discuss these questions with the students: Can they recognize their friend's face from across the room? How about from across a football field? How far away can someone be and still be recognizable?
3. Explain to the students that they will be doing a series of three activities that will teach them how the angular size of objects changes with distance.
4. The small angle activity (Part A) should be done individually. The other two activities (Parts B and C) should be done in teams of three people each. Part A can be eliminated if time is not available.
5. For Part C, "Measuring the Size of a Galaxy Using the Active Galaxy Poster," you will need to affix the poster to a wall, and make sure the students have about 5 meters of clear space between them and the poster. You can mount the poster at the end of a hallway or on the wall of a large classroom.



Assessment:

There are three separate activities that comprise this unit. They can be assessed using the common rubric below either individually or as a group.

| | |
|--|--|
| 4 Points All calculations are correct | 1 Point More than two calculations are incorrect |
| 3 Points One calculation is incorrect, or off by more than 10% | 0 Points No work turned in |
| 2 Points Two calculations are incorrect | |

Transfer Activities:

Students can test the limits of their vision and measure angles of familiar objects. For example, the width of a finger held at arm's length is typically 1–2 degrees. This can be calibrated by having them mark their angle template in degrees from 1–10, and using it to measure the width of their fingers held at arm's length. By comparing the known size of an object (say, the length of a car) to the width of their finger, they can approximate the distance to the object using the small angle formula.

Extension Activities:

Derive the small angle formula more rigorously, following the rules of trigonometry. Given that the Moon is 3500 km in diameter and 0.5° in angular size, have the students calculate the distance to the Moon. Have them look up the correct answer and compare it to their calculated answer.

Reflection Activities:

Where else would the small angle formula be useful? Examples: in surveying, hunting, sports, or anywhere else where gauging the distance would be necessary.

Lesson Adaptations:

If the student is visually impaired, and cannot measure the angles using the template in Activity 2, s/he can be the person whose height is measured, or can use the meter stick to measure distances. If the student is mobility-impaired, s/he can be the person whose height is measured (Student B).



Answer Key for “Zooming In on Active Galaxies”:

Part A:

| Angle (degrees) | Angle (radians) | Tangent (angle) | Difference | % Difference |
|-----------------|-----------------|-----------------|------------|--------------|
| 0.5000 | 0.0087 | 0.0087 | 0.0000 | 0.0025 |
| 1.000 | 0.0175 | 0.0175 | 0.0000 | 0.0102 |
| 2.000 | 0.0349 | 0.0349 | 0.0000 | 0.0406 |
| 4.000 | 0.0698 | 0.0699 | 0.0000 | 0.1628 |
| 8.000 | 0.1396 | 0.1405 | 0.0009 | 0.6550 |
| 15.00 | 0.2618 | 0.2679 | 0.0066 | 2.349 |
| 20.00 | 0.3491 | 0.3640 | 0.0149 | 4.270 |
| 25.00 | 0.4363 | 0.4663 | 0.0300 | 6.870 |
| 30.00 | 0.5236 | 0.5774 | 0.0538 | 10.27 |
| 35.00 | 0.6109 | 0.7002 | 0.0893 | 14.63 |
| 40.00 | 0.6981 | 0.8391 | 0.1410 | 20.19 |

1. The small angle approximation works well for the full Moon.
2. Yes, the small angle approximation should work very well.

Part B: Answers for questions 3 through 8 will depend on each student’s height. Below is a reference table with distances given the students’ height.

| Student Height (cm) | Distance (cm) for 0.17 radians = 10° | Distance (km) for 0.0001 radians = 0.5 arcmin |
|---------------------|--------------------------------------|---|
| 140 | 802.1 | 9.626 |
| 150 | 859.4 | 10.31 |
| 160 | 916.7 | 11.00 |
| 170 | 974.0 | 11.69 |
| 180 | 1031 | 12.38 |
| 190 | 1089 | 13.06 |
| 200 | 1146 | 13.75 |

9. On average, the typical human eye can see objects about $1/60^{\text{th}}$ of a degree across, so the answer to this question is “no.”
10. 13.0 centimeters. Note the significant figures should reflect 0.1 cm accuracy.
11. The distance should be 149 cm. This will depend on their measuring accuracy.
12. This will depend on their distance measurement, but should be close to the actual disk size of 13 cm.
13. This will depend on their accuracy. They should be within 10% or so of the measured size.
14. 893.8 meters.
15. 17.5 centimeters. Note the significant figures should reflect 0.1 cm accuracy.
16. The distance should be 200.5 cm, and will depend on their measuring accuracy.
17. This will depend on their distance measurement, but should be close to the actual lobe size of 17.5 cm.
18. This will depend on their accuracy. They should be within 10% or so of the measured size.
19. 1203.2 meters.
20. 446.9 meters.
21. 1.38 million light years.
22. $100 \text{ million} / 1.38 \text{ million} = 73$, so the magnification would be 73X.

ACTIVITY 2: STUDENT WORKSHEET



A. Testing the Small Angle Approximation

In this activity, you will test “the small angle approximation” in order to determine the limits over which it holds. The small angle approximation states: For small enough angles, the tangent of an angle is equal to the angle itself (when measured in radians). Or: $\tan \alpha = \alpha$ where α is the angle that you are measuring.

In the following table, convert the angles in degrees given in the first column to radians. Write your answers in column 2. Since there are 180 degrees in π radians, use the following conversion equation:

$$\begin{aligned} (\text{angle in degrees}) \times (\pi/180) &= \text{angle in radians} \\ \text{-or-} \\ (\text{angle in degrees}) \times (0.01745) &= \text{angle in radians} \end{aligned}$$

Now find the tangent of the angle and write your answers in column 3 (if your calculator is set to degrees mode, use the numbers in the first column to calculate the tangent. Alternatively, you can use the numbers in the second column to find the tangent, if your calculator is set to radians mode).

In column 4, find the differences between the angle in radians (column 2) and the tangent of the angle (column 3).

In column 5, calculate the percentage difference using your numbers from column 4 and the original angle in radians (column 2), and the following formula:

$$\% \text{ difference} = \frac{\text{difference}}{\text{angle in radians}} \times 100$$

When you fill in the table, make sure you write out the numbers to *four* significant figures.

| Angle (degrees) | Angle (radians) | Tangent (angle) | Difference | % Difference |
|-----------------|-----------------|-----------------|------------|--------------|
| 0.5 | | | | |
| 1 | | | | |
| 2 | | | | |
| 4 | | | | |
| 8 | | | | |
| 15 | | | | |
| 20 | | | | |
| 25 | | | | |
| 30 | | | | |
| 35 | | | | |
| 40 | | | | |

Name: _____ Period: _____ Date: _____



Question 1: One of the largest astronomical objects that you can see in the sky is the Moon, but it is still quite small - the full Moon is only 0.5 degrees across. Would the small angle formula give you a good measurement of the Moon's true size if you knew its distance?

Question 2: The active galaxies with the largest apparent angle in the sky are smaller than the apparent angle of the Moon. If we measure their distance, how accurate do you think the measure of their true size would be? _____

B. Measuring the Angular Size of a Person

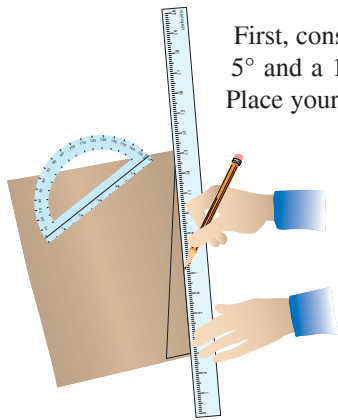

First, construct a template that measures a 5° and a 10° angle to use in the exercise. Place your stiff piece of cardboard in front of you so that one of the long edges is nearest you. Mark a point near the lower right hand corner on that long edge.

Place your protractor so that the hole in the bottom edge of the protractor is centered on the mark on the cardboard.

First, measure a 5° angle going off to the left hand side and mark it. Using a straightedge, connect the first mark to the second, creating a 5° angle with the bottom edge of the cardboard. Make the line as long as possible, and draw it dark enough to see well.

Now label the angle. Draw a little arc going from the bottom of the template up to the 5° line. Next to it, write " 5° ". Then convert that angle to radians and write that number next to where you wrote " 5° ", so it says " $5^\circ = X$ radians", replacing the X with the number you calculated.

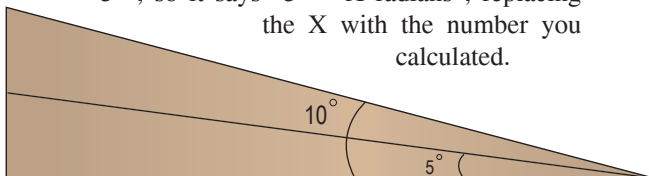

Next, repeat this procedure using a 10° angle. You should now have two lines, one at 5° and the other at 10° , starting at the lower right corner of the

paper and going toward the upper left. Using scissors, carefully cut the cardboard along the 10° angle.

Make sure you cut the vertex of the angle carefully! If the narrow tip of the angle gets cut off, your measurements will be off. When you are done, you should have a long, narrow triangle. The entire angle is 10° , and it should be bisected by a dark line running along it that measures a smaller 5° angle.

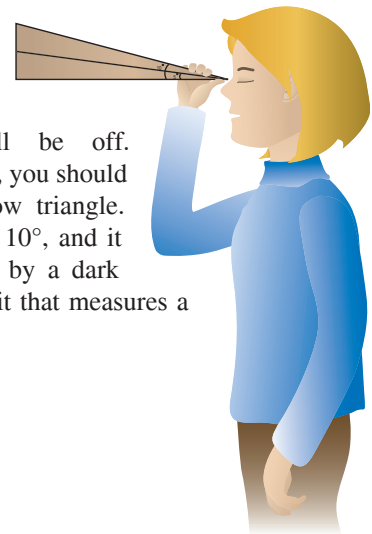

You can check the accuracy of your template by measuring the 10° angle with your protractor again. It should be as close to 10° as possible, but no more than 0.5° off. If it's off by more than that, you'll need to either trim your template or make a new one.

Pick the roles each team member will perform in this activity: *Student A* will be using the template to measure angles, *Student B* will be measured, and *Student C* will be the measurer.

Student C: Using the meter stick, carefully measure the height of Student B to within a centimeter.

Question 3: Height of Student B:
_____ (cm)

Student A will now measure the angular size of Student B. Make sure you have enough room to do this! You'll need about 8-15 meters between them, so you may have to do this in a hallway or outside.

Students A and B: Start off by standing next to each other.

Student C: Mark the position of Student A on the floor/ground. (The mark should represent where Student A's eyes are, and not toes! Gauge where Student A's eyes are over the floor, or simply mark where the ankle is, which is roughly under the eyes.)

Student B: Start walking away from Student A.

Student A: Using the angle template, compare the size of Student B to the 10° angle on the template. (The best way to do this is to pinch the narrow end of the angle with your thumb and index finger, and hold it up to your face on the outside of your eye. That way, the vertex of the angle is aligned with your eye.) When Student B has walked far enough away that s/he appears to be the same size as the 10° angle, tell Student B to stop. Student B may need to move a bit closer or farther to adjust his or her angular size to match the template. If Student B appears smaller than the angle, tell Student B to move closer to you until Student B appears to be the same size as the end of the angle measure.

If Student B appears too large, tell Student B to move away. Match the angle as carefully as you can. Remember, mark the floor under the eyes, not the toes!

Student C: When Student B is at the right distance, mark this position.

Student C: With the meter stick or tape measure, measure the distance between Student A and Student B, to the nearest centimeter.

Question 4: Measured distance:
_____ (cm)

Calculate the height of Student B using the small angle formula: $\alpha = d/D$. In this equation, α is the 10° angle (but in radians!) that you used to position the student, lower case **d** is the height of Student B and upper case **D** is the distance that you have measured in question 4.

Question 5: Calculated height:
_____ (cm)

How close were you able to calculate the actual height? Subtract the calculated value from the measured value.

Question 6: Difference in height:
_____ (cm)

Calculate this difference as a percent:

The percent difference in distance =

$$\frac{(\text{measured} - \text{calculated})}{(\text{measured})} \times 100$$

Question 7: Percent difference:

How far away would Student B have to stand from Student A in order to have an angular measure of 0.5 arcminutes, the approximate resolution of GLAST? Remember there are 60 arcminutes in a degree, and you must convert the 0.5 arcminute angle to radians. Use the small angle formula to express your answer in kilometers, to the nearest 10 meters (0.01 km)

Question 8: Distance for 0.5 arcminutes: _____ (km)

Question 9: Do you think you would still be able to see Student B as more than a dot with your unaided eye from that distance?

C. Measuring the Angular Size of a Galaxy Using the Active Galaxies Poster

Student C: With a meter stick or metric ruler, measure the diameter of the disk along its longest dimension using the *middle* picture on the left of the poster. Measure to the nearest 0.1 centimeters.

Question 10: AG disk size: _____ (cm)

Student A: Move away from the poster until the gas disk in the middle left panel of the poster subtends an angle of 5° as measured with the cardboard angle template.

Student C: Mark the spot on the floor as in the previous exercise, and measure the distance from Student A to the poster.

Question 11: Measured disk distance (5°): _____ (cm)

Using your answer from question 11 and the small angle formula, calculate the size of the disk to the nearest 0.1 centimeters.

Question 12: Calculated disk size (5°): _____ (cm)

How accurate was your measurement? Calculate the percent difference between the measured and calculated sizes of the disk.

Question 13: Percent difference in disk sizes: _____

Using the small angle formula, calculate *how far* you would have to stand from the poster so that the disk would subtend 0.5 arcminutes - the resolution of the GLAST telescope. Express your answer in meters.

Question 14: Disk distance (0.5'): _____ (m)

Student C: With a meter stick or metric ruler, measure the radio lobe span of the AG in the *upper left corner* of the poster, from **radio lobe tip** to radio lobe tip.

Question 15: AG radio lobe size: _____ (cm)

Find the distance from the poster so that the radio lobes (from tip to opposite tip) subtend an angle of 5° .

Question 16: Measured radio lobe distance (5°): _____ (cm)

Using your answer from question 16 and the small angle formula, calculate the size of the radio lobes to the nearest 0.1 cm.

Question 17: Calculated radio lobe size (5°): _____ (cm)

Calculate the percent difference in your measured versus calculated sizes for the radio lobes.

Question 18: Percent difference in radio lobe sizes: _____

How far would you have to stand from the poster so the radio lobes subtend 0.5 arcminutes? Express your answer in meters.

Question 19: Radio lobe distance (0.5'): _____ (m)

What are the limits of your own vision? The *average* human eye can just barely distinguish two objects that are 1 arcminute apart. (Your own vision may vary from this.) Using the small angle formula, determine how faraway the poster would have to be in order for you to barely see the disk as more than a dot. Express your answer in meters.

Question 20: Limit Distance: _____ (m)

Look again at your answer for Question 9. Did you answer the question correctly?

The disk of NGC 4261 (see image below) is 400 light years in diameter. Use the small angle formula to determine the maximum distance (in light years) at which you could see this disk as more than a dot with your naked eye. (NOTE: To see something as more than a dot, its angular size must be at least 1 arcminute).

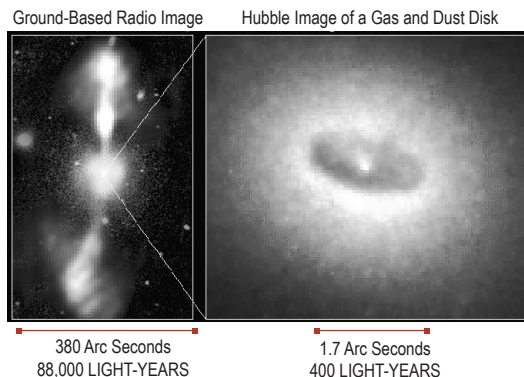

Question 21: NGC 4261 Distance (1'): _____

Compare your answer to the actual distance to NGC 4262 of 100 million light years. What is the ratio of these distances?

Question 22: Ratio:

$$\frac{\text{actual}}{\text{actual for } 1'}$$



ACTIVITY 3: LIGHT TRAVEL TIME AND THE SIZE OF ACTIVE GALAXIES



Science Concept: *The changes in the intensity of a galaxy's light can be used to measure the size of the galaxy.*

Duration:
45 minutes

Background Information

Active galaxies do not usually emit a steady stream of light. Instead, their brightness can change dramatically over the span of weeks, days and even minutes. GLAST will detect this variability from thousands of AGs with great accuracy. Amazingly, this variability can tell astronomers quite a bit about the AG itself, including its size!

Astronomers can find the size of the AG emitting region using a clever technique. It involves knowing the speed of light, and being able to set limits on how quickly an object can change its brightness.

Imagine an object that measures one **light-week** across as in the figure below. Suppose that the entire object emits a brief flash of light. Photons from the part of the object nearest to the Earth arrive at our telescopes first. Photons from the middle of the object arrive at the Earth some time later. Finally, light from the far side of the object arrives after a measurable time difference from the arrival of the first photons. Although the object emitted a sudden flash of light, we observe a gradual increase in brightness that lasts a full week,

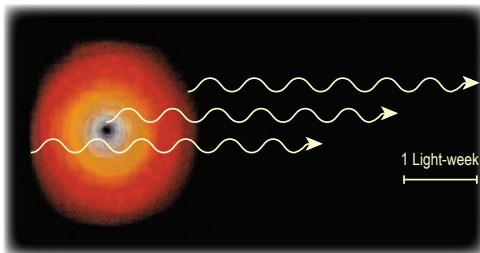

Active galaxy emits light flash that travels to observer. (Artist's illustration)

from the first recorded incident. In other words, the flash is stretched out over a time interval equal to the difference in the light travel time between the nearest and most remote observable regions of the object.

If an object is 1 light-year in diameter, it will take 1 year longer for the signal from the *far* side of the object to be detected than the signal from the *near* side. To calculate the diameter of the emission region from the duration of the brightness variation we multiply the velocity of light (called *c* which equals 3×10^8 m/s), by the length of time (called Δt or "delta t") it takes the AG to change brightness. When multiplied together they tell you the size of the emitting region:

$$\begin{aligned} \text{Size of emitting region} &= \\ &(\text{speed of light}) \times (\text{time of variation}) \\ &\text{or} \\ \text{Size} &= c\Delta t \end{aligned}$$

Astronomers refer to this technique as using the light travel time ($c\Delta t$) to find the size of an object.

Example: A time variation of one week is observed. Determine the diameter of the AG's active region:

$$\begin{aligned} d &= (\text{speed of light}) \times (\text{time of variation}) \\ &= (3 \times 10^8 \text{ m/s}) \times (1 \text{ week}) \end{aligned}$$

Since 1 week = 7 days x 24 hrs/day x 3600 sec/hr

$$\begin{aligned} &= 604,800 \text{ seconds} \\ d &= (3 \times 10^8 \text{ m/s}) \times (604,800 \text{ seconds}) \\ d &= 1.81 \times 10^{14} \text{ m} \end{aligned}$$

The solar system is roughly 10^{13} meters across, so the AG emitting region in this example is about

18 times the diameter of the solar system - an astoundingly small distance given that a typical AG can have a billion times the mass of our sun and about 1000 times the luminosity of the entire Milky Way galaxy!

There is a limit to this method. For example, if you only observe an object once a day, you won't see variations shorter than that timescale. Therefore, the smallest region you can measure is 2 light days (about 5×10^{13} meters, or five times the diameter of the solar system) across. The region is 2 light days across because you need to observe the object once, see its brightness rise, then see it fall. That takes three observations; the first, the second a day later, and the third a day after that: a two day interval. So when you measure the size based on brightness variations, it's really an upper limit. There might be smaller scale regions, but you cannot detect them.

Also, the object may be emitting over various timescales: there may be short duration bursts or **flares** on top of much longer, slower variations. Generally speaking, astronomers assume that the *shortest* duration variation is what tells us the size of the emitting region. The speed of light is the *maximum* speed the variation can travel across the object, but there may be slower methods too. So the quickest variation gives you an upper limit to the size of the region. It may be smaller than the calculated size, but not bigger.

In this exercise, the student takes data from a graph (see page 26) and uses it to calculate the total energy emitted by a flare every second. The **flux** from an object is defined as the amount of energy that passes through an area of one square meter every second. In the case of the graph of a flare from 3C279 (see page 26), the plot shows the **photon** flux, which is the number of gamma-ray photons hitting one square meter every second. The graph is telling us that the flare generated about 5×10^{-2} photons per square meter per second. If we assume that each gamma ray hitting the detector has an energy of 100 million **electron Volts** (abbreviated 100 MeV; about 100 million times the energy of a visible light photon), the photon flux can be converted to an energy flux.

That energy flux is the amount of energy hitting a square meter every second here on Earth. The Earth is at a vast distance from 3C279, so we only intersect a tiny fraction of the total energy emitted. If we could put a sphere around 3C279 such that

the radius of the sphere is the distance from the Earth to the active galaxy, we would capture all the energy. If you add up all the energy in every square meter of the sphere, you will have the total energy emitted by the flare per second, what astronomers call the **luminosity**. The students will first find the flux from the graph, then multiply it by the total area of that sphere, yielding the total luminosity of the flare. By dividing by the Sun's luminosity, they can directly compare the energy of the flare to the energy of the Sun. The ratio is huge, meaning that the flare emitted vastly more energy than the Sun does. Finally, they will calculate how long it would take the Sun to emit as much energy as the flare did in one second. The answer may surprise (and humble) you: the flare emitted about 36 *trillion* times as much energy as the Sun does every second, or the amount of energy emitted by the Sun for over a million years!

Ask the students to think about that number for a moment. This was a single flare emitted by an object. The ratio they calculated was the energy of the flare in gamma rays *only* to the *total* energy of the Sun! In reality, even more energy was emitted by the flare, since the flare also emitted X-rays, ultraviolet, optical light, etc. Ask them if they would want to be anywhere near this object, and comment on what might happen if our own Milky Way Galaxy became an active galaxy.



Materials for each student:

- calculator
- pencil



Objectives:

Students will be able to use a simple equation to determine the size of a flare emitting region given the rise and decay times.

Students will be able to measure the rise and decay times of a flare using a plot with actual NASA data from an active galaxy.

Students will be able to compare the total energy emitted by the flare to the energy of the Sun.

Procedures:

1. Introduce the activity by reviewing information in the *Introduction to Active Galaxies* (page 5) and in the activity *Background Information* (page 22).
2. Discuss the speed of light with the students in terms of the distance covered in a given amount of time. How long would it take a beam of light to cross the Earth? Travel to the Moon? The Sun? The scale of the Universe is a very misunderstood topic; covering this topic before the activity will give the students a better sense of that scale. Ask them if a light year is a unit of distance or time. Many students will say “time,” but the light year is a unit of length (equal to 9.5×10^{15} m).
3. Explain to the students that they will be doing two activities to measure the size and energy of a flaring region in an active galaxy. In the first activity, they will use a simple equation to determine the size of the region given the duration of a flare from that region. In the second they will measure the rise and decay times themselves using a plot with actual NASA data of an active galaxy. From there, they can compare the total energy emitted by the flare to the energy of the Sun.
4. The activities should be done individually.

Transfer Activities:

The idea that distance equals (speed x time) can be applied to many situations. For example, a car traveling at 100 kilometers per hour for two hours will travel a total of 200 kilometers. Have the students calculate the distance they can travel in a given time (say, 3 hours) given different vehicles: walking at 5 km/hr, bicycling at 30 km/hr, a car at 100 km/hr, a plane at 1000 km/hr, a satellite at 11 km/sec.

Extension Activities:

Do we see galaxies as they are “all at once,” or do we see some parts before others? A variation on the travel time idea is to use the delay between seeing an object and hearing a noise it makes to determine its distance. Imagine a lightning storm kilometers across, with two simultaneous bolts, one from the near side and the other from the far side. Do we hear the thunder at the same time? (No.) Do we see the bolts at *exactly* the same time? (No.) Is the delay between the two sounds the same as the delay between the two flashes? (No; the flashes are separated by milliseconds while the thunderclaps are separated by many seconds.) Given the speed of sound (~500 meters/second), have the students determine the distance to a lightning bolt given the delay in hearing the sound. (Each second of delay corresponds to 500 meters of distance.)

Reflection Activities:

How do dolphins use the differences in travel time in reflected sounds to see around them? Bats? Ask the students to think of where else this technique might be useful (radar, echo mapping of planet surface, distance to lightning storm).

Assessment:

There are two separate activities that comprise this unit. They can be assessed using the common rubric below either individually or as a group.



| | | |
|---|--------|---|
| 4 | Points | All calculations are correct |
| 3 | Points | One calculation is incorrect, or off by more than 10% |
| 2 | Points | Two calculations are incorrect |
| 1 | Point | More than two calculations are incorrect |
| 0 | Points | No work turned in |



ACTIVITY 3: STUDENT WORKSHEET

A. Finding the Size of an Active Galaxy Flare Region

1) Use the equation: distance = $c\Delta t = (3 \times 10^8 \text{ m/s}) \times \Delta t$ to determine the diameter of the active regions of AGs in meters and in units of the **solar system** diameter (use 10^{13} meters for the solar system diameter), for flares of duration $\Delta t = 1$ hour, 1 day, 1 week and 1 year.

| Time | Size (meters) | Size (solar system) |
|--------|---------------|---------------------|
| 1 hour | | |
| 1 day | | |
| 1 week | | |
| 1 year | | |

2) Given the diameter of the sun (1.4×10^9 meters), what is the fastest the entire sun can vary in brightness, as measured in seconds?



Question 1: Time for solar variation (seconds): _____

B. Measuring the Size of an Active Galaxy Flare Region

The plot to the right is real astronomical data taken by the EGRET gamma-ray instrument that was onboard NASA's Compton Gamma Ray Observatory. It observed the active galaxy 3C279 for several years, and found many flares and other variations in the AG's light.

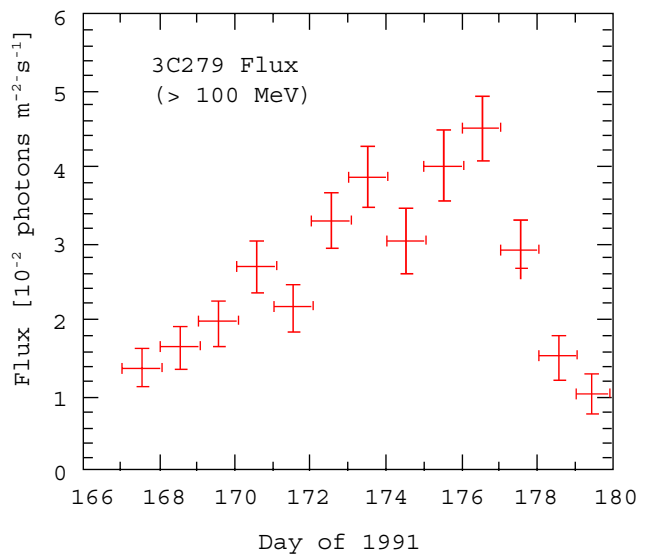

Light Travel Time & Size p.1

Name: _____ Period: _____ Date: _____

There are two characteristic timescales for the variation shown. One is the “rise time,” or time it takes the brightness to reach its peak. The other is the “decay time,” or the time it takes for the brightness to drop back down to the normal level.

For the following exercise, assume the normal level of brightness for 3C279 is about 1×10^{-2} photons/m²s⁻¹ (that is, the “1” on the graph’s y-axis).

Using only the data points where the flare is brightening, draw a “best-fit” line through the points. Do the same for the points where the flare is fading.

Use your hand-drawn line to determine the time duration (Δt) for the *rise* time of the flare. From that, calculate the size of the emitting region using $\text{size} = c\Delta t$ in both meters and in solar systems.

Question 2: Time scale of rise

(days): _____

Question 3: Size of emitting region

(meters): _____

Question 4: Size of emitting region

(solar systems): _____

Use your hand-drawn line to determine Δt for the *decay* time duration of the flare. From that, calculate the size of the emitting region using $\text{size} = c\Delta t$ in both meters and in solar systems.

Question 5: Time scale of decay

(days): _____

Question 6: Size of emitting region

(meters): _____

Question 7: Size of emitting region

(solar systems): _____

Question 8: The size of the region that is actually emitting the flare will be the smaller of the two. Why?

Using your hand-drawn line to the rising portion of the flare, determine the slope and intercept of the line ($y = mx + b$).

Question 9: Slope of growth:

Y-intercept:

Do it again, but for the decaying portion of the flare.

Question 10: Slope of decay:

Y-intercept:

If the flare had continued to rise for two more weeks, how bright would it have been?

Question 11: Brightness of flare after two more weeks (in the same units as the graph):

Question 12: Assuming the flare took two more weeks to rise than shown in the plot, but still decayed at the same rate, what does this imply about the size of the flaring region? Would it be bigger, smaller, or the same size as you found in the original plot?

C: Measuring the Energy Emitted by an Active Galaxy Flare

From the graph, it's possible to determine the total energy emitted during the maximum of the flare and compare it to the energy emitted by the Sun. First, convert the units of the graph from photon flux to energy flux. Assume that each gamma ray hitting the detector has an energy of 100 MeV. Calculate the *maximum* flux in $\text{MeV m}^{-2} \text{s}^{-1}$.

Question 13: Flux of flare in $\text{MeV m}^{-2} \text{s}^{-1}$: _____

A more usual unit of energy is the **Joule**, which is equal to 6.3×10^{18} eV. Remembering that 1 MeV is 10^6 eV, what is the flare flux in $\text{Joule m}^{-2} \text{second}^{-1}$?

Question 14: Flux of flare in $\text{Joule m}^{-2} \text{s}^{-1}$: _____

The flux is the amount of energy hitting a square meter here on Earth. The total energy emitted by the flare every second is spread out over a sphere centered on the flare, with a radius equal to the distance from the Earth to the flare. The distance to 3C279 is about 4×10^9 light years, and there are 9.5×10^{15} m in a light year. The surface area of a sphere is $A = 4\pi r^2$ where "r" is the radius of the sphere. What is the total surface area of the sphere?

Question 15: Surface area of sphere (m^2): _____

The total luminosity emitted in the flare each second, is given by $E = (\text{Area}) \times (\text{Flux})$. Calculate the energy in Joules/sec.

Question 16: Total energy emitted per second by the flare (Joules/second):

The Sun's luminosity is about 4×10^{26} Joules/second. What is the ratio of the luminosity at the flare maximum to the solar luminosity?

Question 17: Total luminosity of the flare in Solar units:

There are about 3×10^7 seconds in a year. How many years would it take for the Sun to emit as much energy as the flare did in a single second?

Question 18: Number of years for the Sun to emit as much energy as the flare did in 1 second:

GLOSSARY



Definitions

Accretion Disk: the flattened disk of matter swirling just outside the black hole.

Active Galaxy: a galaxy with an unusually large amount of energy emitted from the nucleus.

Angular Size: the angle between the lines of sight to the two opposite sides of an object.

Annular: shaped like or forming a ring.

Apex: the point or tip of the cone; a peak.

Arcminute: 1/60th of a degree.

Black Hole: an object so small and dense that inside its event horizon, the escape velocity is faster than the speed of light. In an active galaxy, the central black hole may have millions or even billions of times the Sun's mass.

Blazar: a quasar that one is viewing directly down the jet axis.

Degree: 1/360th of the circumference of a circle.

Electron Volt (eV): a unit of energy commonly used in astronomy. A typical gamma ray has an energy of about 100 million electron Volts (100 MeV).

Flare: a sudden, dramatic increase in brightness of an object.

Flux: the amount of energy passing through an area of one square meter every second.

Galaxy: a collection of gas, dust, and billions of stars.

Jet: a thin, highly focused beam of matter and energy emitted from the nuclei of some active galaxies. Jets can be hundreds of thousands of light years long.

Joule (J): a unit of energy, equal to 6.3×10^{18} eV.

Light-Week: the distance light travels in a week; approximately 181 billion kilometers (1.8×10^{11} kilometers) or 1.8×10^{14} m.

Light-Year: the distance light travels in one year; approximately 10 trillion kilometers (10^{13} kilometers) or 9.5×10^{15} m.

Luminosity: the total energy emitted by an object per second.

Photon: an individual quantum or particle of light.

Quasar: An active galaxy so distant it appears star-like.

Quiescent: at rest; inactive.

Radian: $1/(2\pi)$ of the circumference of a circle. One radian = 57.3 degrees

Radio galaxy: a galaxy that is a powerful source of radio waves.

Radio Lobe: A large radio-wave emitting cloud of matter located at the ends of the jets in some active galaxies, formed when the matter from the jet is slowed by intergalactic material.

Seyfert galaxy: an active galaxy (named for astronomer Carl Seyfert) where the inner disk is tipped to our line-of-sight, allowing us to see higher energy light from the nucleus.

Solar System: a collection of planets, moons, comets, etc. which orbits a star. Our solar system is roughly 10^{10} kilometers (10^{13} meters) across.

Torus: A doughnut-shaped object. Gas and dust outside the accretion disk in an active galaxy orbit the central black hole in a torus-shaped region.

Acronyms

AG: Active Galaxy

E/PO: Education and Public Outreach

GBM: GLAST Burst Monitor

GLAST: Gamma-Ray Large Area Spave Telescope

HST: Hubble Space Telescope

LAT: Large Area Telescope (on GLAST)

NASA: National Aeronautics and Space Administration

SSU: Sonoma State university

DETAILED STANDARDS FOR EACH ACTIVITY



Activity 1: *Building Perspectives with Active Galaxies*

↪ Science Standards:

Content Standard A: Science as Inquiry

Abilities necessary to do scientific inquiry

- Students investigate their model of an AG and compare/contrast it with images of real galaxies using logic and evidence from real and constructed models.
- Reflection and transfer activities give the students the opportunity to extrapolate what they have learned to everyday experiences.

Understandings about scientific inquiry

- Results of scientific inquiry: by examining the model AG, the students will be able to grasp why scientists developed the unified model of active galaxies, and why there are so many different types of active galaxies.

Content Standard D: Earth and Space Science

Origin and Evolution of the Universe

- Galaxies are a fundamental structure in the Universe, and the supermassive black holes in their nuclei are in turn a fundamental part of galaxies. This activity strengthens students' understanding of the structure of galaxies.

Content Standard E: Science and Technology

Understandings about science and technology

- Students see that in order to understand the wide range of astronomical objects they must use different techniques to observe them.
- Students should understand that *looking* at the objects isn't enough; scientists must use their imagination to understand objects they cannot see.

Content Standard G: History and Nature of Science

Science as a human endeavor

- Students will understand the initial confusion of scientists about active galaxy types, and how scientists were able to make progress in understanding them.

↪ Mathematics Standards:

Algebra: *Use mathematical models to represent and understand quantitative relationships.*

- The model of the AG is constructed by using measurements and analyzed to see the relationship to the real object in space.

Geometry: *Analyze characteristics and properties of two- and three-dimensional geometric shapes and develop mathematical arguments about geometric relationships*

- Students observe the finished models and create illustrations to show how two-dimensional representations of a three-dimensional object can change under rotation.

Apply transformations and use symmetry to analyze mathematical situations

- Students examine the symmetry of the AG model at different aspect angles.

Use visualization, spatial reasoning, and geometric modeling to solve problems

- Students use their constructed AG to analyze and illustrate its appearance at different angles. The geometry of the model is critical to understanding the relationships of the different active galaxies.

Measurements: *Understand measurable attributes of objects and the units, systems, and processes of measurement*

- The construction of the model involves measurements to create the components. The properties (size, shape, etc.) of the actual active galaxy cores are compared to the models. The students make decisions about units and scales.

Apply appropriate techniques, tools and formulas to determine measurements

- The construction of the AG model involves formulae to determine, for example, the size of the torus. The students answer questions about the size and shape of the various model components.

Use representations to model and interpret physical, social and mathematical phenomena

- Students construct AG models and compare/contrast them with images of real galaxies.

Activity 2: Zooming In on Active Galaxies

↪ Science Standards:

Content Standard A: Science as Inquiry *Abilities necessary to do scientific inquiry*

- Students make calculations to test the small angle formula (hypothesis and observation).
- Using their own calculations, the students formulate and revise the theory about an object's size.
- After having analyzed measurements of nearby objects, students answer questions that engage thought and analysis about real objects in space.

Understanding about scientific inquiry

- Students learn how scientists determine the distance and/or size of an object in space.

Content Standard B: Physical Science

Motion and Forces

- Jets of materials are ejected at velocities near light speed from the black hole in an AG. Students answer questions to help them see how big the jets from AGs are, and how we can see them at vast distances.

Content Standard D: Earth and Space Science

Origin and Evolution of the Universe

- Active galaxies are a fundamental part of the evolutionary process of the universe.

Content Standard E: Science and Technology

Understanding about science and technology

- The small angle formula is an essential tool used by astronomers to get physical dimensions of astronomical objects.

Content Standard G: History and Nature of Science

Science as a human endeavor

- Students answer questions about the ability of the human eye to distinguish objects, showing how this activity affects them in daily life.
- Students see that by working in groups they can formulate better hypotheses about scientific inquiries due to the extra input from others.

↪ Mathematics Standards:

Numbers and Operations: *Compute fluently and make reasonable estimates*

- Students calculate the accuracy of the small angle formula and complete a table of these values.
- Students compute sizes and distances of teammates, drawings on the poster and actual astronomical objects. They estimate limits of the human eye's resolution.

Algebra: *Represent and analyze mathematical situations and structures using algebraic symbols*

- The small angle formula uses algebra to determine the distance and size of objects.

Use mathematical models to represent and understand quantitative relationships

- Students determine the relationship between size and distance, measure these properties in teammates and compare these measurements to AGs.

Geometry: *Analyze characteristics and properties of two- and three-dimensional geometric shapes and develop mathematical arguments about geometric relationships*

- Students measure the apparent two-dimensional diameter of three-dimensional objects (teammates), and see how this changes with distance.

Use visualization, spatial reasoning, and geometric modeling to solve problems

- Students investigate two- and three-dimensional objects and see the relationship of the size of the object relative to themselves.

Measurements: *Understand measurable attributes of objects and the units, systems, and processes of measurement*

- Students measure themselves and drawings on a poster using various units, and compare them to astronomical distances and sizes.

Apply appropriate techniques, tools and formulas to determine measurements

- Students use the small angle formula and measurements of each other to gather information about the physical characteristics of objects. Percent difference (error margin) is also used.

Activity 3: *Light Travel Time and the Size of Active Galaxies*

↪ Science Standards:

Content Standard A: Science as Inquiry

Abilities necessary to do scientific inquiry

- Using astronomical data similar to that used by professionals, the students investigate light seen from an AG. Students must formulate and revise scientific explanations based on the series of questions being asked of them.

Understanding about scientific inquiry

- Students see that scientists analyze scientific data in plots to find valuable information about the objects being researched.

Content Standard B: Physical Science

Interactions of Energy and Matter

- Active galaxies are a huge source of energy. Students map this energy and use it to determine the physical size of the region emitting the energy.
- The amount of energy in gamma rays emitted by an AG is compared to the total energy emitted by the Sun across the entire electromagnetic spectrum to show that an AG is a much larger source of energy.

Content Standard D: Earth and Space Science

Origin and Evolution of the Universe

- Active galaxies are a fundamental part of the evolutionary process of the Universe.

Content Standard E: Science and Technology

Understanding about science and technology

- Students learn a method of analysis that scientists commonly use to investigate properties of astronomical objects. Students learn that a simple graph can reveal a large amount of information about an AG.

Content Standard G: History and Nature of Science

Science as a human endeavor

- Students do a field study (analyzing real data) as a scientist does.

↪ Mathematics Standards:

Numbers and Operations: *Compute fluently and make reasonable estimates*

- Students determine numbers from a graph, convert units, and calculate various quantities such as surface area, total energy emitted from a flare, and timescales of phenomena.

Algebra: *Understand patterns, relations, and functions*

- Students analyze a plot, calculate the rate of change in the plot, and extrapolate from the data.

Represent and analyze mathematical situations and structures using algebraic symbols

- Students determine the point-slope equation of a line, extrapolate the data, and use it to determine physical characteristics of an AG.

Analyze change in various contexts

- Students interpret rates of change of the luminosity of an AG using graphical data.

Measurements: *Apply appropriate techniques, tools, and formulas to determine measurements*

- Students analyze the data and the error in their measurements.
- Students determine the equation of a line from a graph, extrapolate that data, and use the extrapolated data to determine physical characteristics of AGs.

Data Analysis and Probability: *Develop and evaluate inferences and predictions that are based on data*

- Students calculate the luminosity of an AG flare by extrapolating from the given data.



RESOURCES

- ① For more information on GLAST and active galaxies, see the GLAST Education and Public Outreach web site:
<http://glast.sonoma.edu>
- ① This educational unit can be found on the GLAST Education and Public Outreach web site at:
<http://glast.sonoma.edu/teachers/teachers.html>
For a copy of the GLAST Active Galaxies poster, and activity booklet, please contact:
⇒ materials@universe.sonoma.edu
- ① The Center for Astrophysical Research in Antarctica has an interesting web page with small angle formula activities:
<http://astro.uchicago.edu/cara/outreach/resources/ysi94/smallangle.html>
- ① A tutorial covering the discovery of quasars and how their size can be measured using $c\Delta t$:
<http://casswww.ucsd.edu/public/tutorial/Quasars.html>
- ① Bill Keel's Active Galaxies page:
<http://www.astr.ua.edu/keel/agn/>
- ① Active Galaxies from University of Maryland:
<http://www.astro.umd.edu/education/astro/actgal/actgal.html>
- ① Ted Bunn's Black Hole tutorial:
<http://cosmology.berkeley.edu/Education/BHfaq.html>
- ① Compton Gamma-Ray Observatory and EGRET:
<http://coss.c.gsfc.nasa.gov/index.html>
- ① GLAST Project Site at Goddard Space Flight Center. This is the official site for GLAST Project Management at NASA's Goddard Space Flight Center:
<http://glast.gsfc.nasa.gov/>
- ① GLAST Large Area Telescope (LAT) Collaboration. The GLAST LAT is being managed by personnel at Stanford University. This is the official site for the LAT experiment:
<http://www-glast.stanford.edu/>
- ① GLAST Burst Monitor (GBM). The GBM is being managed by personnel at NASA's Marshall Space Flight Center. This is the official site for the GBM experiment:
<http://gammaray.msfc.nasa.gov/gbm/>

EDUCATOR REPLY CARD



Affix
First Class
Stamp

Active Galaxies Activities Feedback
NASA EPO
Sonoma State University
1801 E Cotati Avenue
Rohnert Park, CA 94928



Active Galaxies Activities

Educator Reply Card

To achieve America's goals in Educational Excellence, it is NASA's mission to develop supplementary instructional materials and curricula in science, mathematics and technology. NASA seeks to involve the educational community in the development and improvement of these materials. Your evaluation and suggestions are vital to continually improving NASA educational materials.

Please take a moment to respond to the statements and questions below. You can submit your responses through the Internet or mail. Enter your reply at the following Internet address:

<http://glast.sonoma.edu/agna/>

You will then be asked to enter your data at the appropriate prompt.

Otherwise, please return the card by mail. Thank you.

- With what grades did you use the Active Galaxies Activities?
 Number of Teachers/Faculty:
 ___ K-4 ___ 5-8 ___ 9-12 ___ Community College
 College/University ___ Undergraduate ___ Graduate
 Number of Students:
 ___ K-4 ___ 5-8 ___ 9-12 ___ Community College
 College/University ___ Undergraduate ___ Graduate
 Number of Others:
 ___ Administrators/Staff ___ Parents ___ Professional Groups
 ___ General Public ___ Civic Groups ___ Other
- What is your home 5- or 9-digit zip code? _____
- This is a valuable resource for educators:
 Strongly Agree Agree Neutral Disagree Strongly Disagree
- I expect to apply what I learned in the Active Galaxies Activities:
 Strongly Agree Agree Neutral Disagree Strongly Disagree

5. What kind of recommendation would you make to someone who asks about the Active Galaxies Activities?

Excellent Good Average Poor Very Poor

6. How did you use the Active Galaxies Activities?

- Background Information Critical Thinking Tasks
- Demonstrate NASA Materials Demonstration
- Group Discussions Hands-On Activities
- Integration Into Existing Curricula Interdisciplinary Activity
- Lecture Science and Mathematics Standards Integration
- Team Activities
- Other: Please specify: _____

7. Rate the following items from the Activities according to their educational usefulness-H(igh) M(edium) or L(ow) (leave blank if you did not use):

___ Building Perspectives

___ Zooming In on Active Galaxies

___ Light Travel Time and the Size of Active Galaxies

___ Active Galaxies Poster

8. Which activity did you find particularly helpful?

9. How can we make the activities more effective for you?

10. Additional comments:

Today's Date: _____