

NEW OPTICAL INSTRUMENTATION FOR SEDIMENT RE-SUSPENSION MEASUREMENTS

J. A. Northby

Physics Department, University of Rhode Island, Kingston, RI, 02881 (jnorthby@uri.edu)

Keywords: Suspended Sediment, Optical, Velocimeter, Instrumentation

ABSTRACT

A prototype of a new optical instrument for non-invasive measurement of the velocity and magnitude of suspended sediment particles near the water-sediment interface has been developed. Preliminary studies carried out in a flowing seawater tank in a laboratory environment will be described. Velocity measurements were easily accomplished, and compared well with another more obtrusive instrument. It appears that simultaneous information about the suspended particle size distribution also can be obtained under suitable circumstances.

INTRODUCTION

Studies of sediment re-suspension processes require an understanding of the motion and characteristics of the suspended sediments within the last few centimeters of the seabed. In particular, the quantities that must determine re-suspension and transport are the fluid's fine scale fluctuating velocity and velocity gradients at the interface. A major difficulty in attacking these problems is the relative lack of suitable non-invasive instrumentation with which to make such measurements. Several non-invasive methods for measurement of the velocity and concentration of sediment particles have been utilized in the near-bed region. Often, one technique by itself was not able to provide the required information and two or more were used together. Typical acoustic methods are described, for example, by Betteridge et al.(2002), Voulgaris and Trowbridge (1998) and by Hay and Sheng (1992). Typical optical methods are described by Downing et al.(1981), Traykovski et al. (1999), Agrawal and Aubrey (1992), and Bertuccioli et al.(1999). Inter-comparisons of optical and acoustic methods are discussed by Osborne et al.(1993) and by Creed et al.(2001). We have developed a prototype of a new kind of optical instrument that should be capable of providing the needed information. It has been operated in an open flowing seawater system in a laboratory environment, but has not yet been utilized in any field measurements.

METHOD

Our primary objective was to develop a non-invasive optical method of measuring the velocity in a 1cm^3 volume element located just above the sediment layer. We wanted to make an instrument that would be less sensitive to window quality and water clarity than present optical methods, which rely on coherent and/or sharply focused light, and one that would offer the potential of less expensive replication. The method we have chosen is one that shifts the burden from high quality optical and laser systems, which are expensive, to high quality electronic capability, which is not. The present device was designed to show that the ideas were reasonable without

spending very much money rather than to provide an instrument optimized for immediate deployment in the field. For example, to demonstrate the remoteness of the method, the sensitive volume element was located roughly 30 cm from the nearest instrumental surface. This restricts the present instrument to conditions of relatively low sediment load. A more practical device could work as well with a shorter path length without distorting the flow. The useful velocity range was set to be roughly tidal velocities (~ 1 cm/s to 100 cm/s), which restricts its application to typical estuarine flow conditions. This is not a limitation of the method, but only of the design parameters selected.

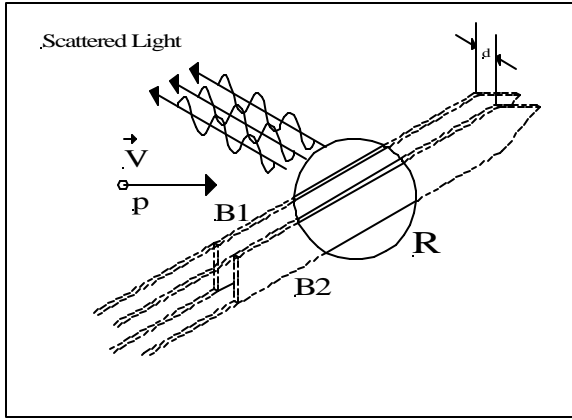

Figure 1a: Particle Crossing Ribbon Pair.

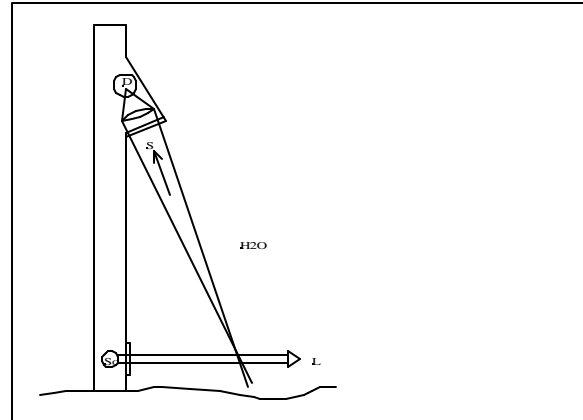

Figure 1b: Detector Configuration.

The initial method we have chosen involves projecting a pair of ribbons of light, just above the sediment interface, as sketched in Figure 1a. A sediment particle entrained with the fluid and crossing both beams will scatter two pulses of light. A lens located at some distance from the volume element under study images the scattered light from this region on a detector, as sketched in Figure 1b. The time between the pulses, t_d , is a measure of the velocity component normal to the beam pair, V_x ,

$$V_x = \frac{d}{t_d}, \quad (1)$$

where d is the separation between the two beams. Of course, in a real situation there will be many particles crossing the beams in a short time and it would be impossible to sort out which pulses belong to which particle. The scattered light from each beam will be a noisy signal, but the two signals, $S_1(t)$ and $S_2(t)$ will be correlated. If we evaluate the cross-correlation function of the signals,

$$f(t) = \int S_2^*(t) S_1(t+t) dt, \quad (2)$$

the peak of the function f will give us the average delay between the two signals, t_d . Inserting this value in Eq. 1 gives the velocity component, even though we can't resolve the separate pulse pairs. We should emphasize the fact that t_d can be either positive or negative, and thus the direction, and not just the magnitude of the velocity component, is obtained in this way. As a result, we can add other nominally orthogonal intersecting beam pairs to obtain unambiguously the full three dimensional velocity if desired.

The problem, of course, is that we need a method to sort out which scattered light comes from which beam, since the light is all superimposed in a single detector. Our solution is to form each ribbon of light from a different (but identical) laser diode. Each diode is turned on and off at its own high frequency, so the scattered light from a given beam is “tagged” with its own frequency and phase. If the frequencies and phases are suitably selected, and are much higher than any scattered signal frequencies, it is straightforward to extract each signal into its separate channel by phase sensitive detection techniques, while still maintaining the scattered signal bandwidth needed to evaluate the cross-correlation function. There are several advantages to this method. For example, all the light sources have the same wavelength, so most background light can be excluded from the detector by a suitable narrow band interference filter. Background light that does reach the detector is not modulated, so it doesn’t contribute to the signals except possibly as increased noise. Thus the method works well in ambient light. In addition, the main properties required of the laser diodes are the relatively pure wavelength, the high specific brightness, and the high switching speeds. These can be obtained with quite inexpensive diodes, in contrast to the lasers required for coherent light and/or sharply focused devices. Here, the complexity is primarily in the electronics required for modulating and demodulating the signals. While complex, the devices are inexpensive and easily replicated. Finally, the beams utilized in our method are incoherent, and thus not particularly affected by weak isotropic scattering from biofouling of windows or from microscopic sediment in the water. The result of the scattering should be to reduce the resolution of the measurement, but not its accuracy. In other words, the cross-correlation peak may broaden, but its center should not shift.

EXPERIMENTS

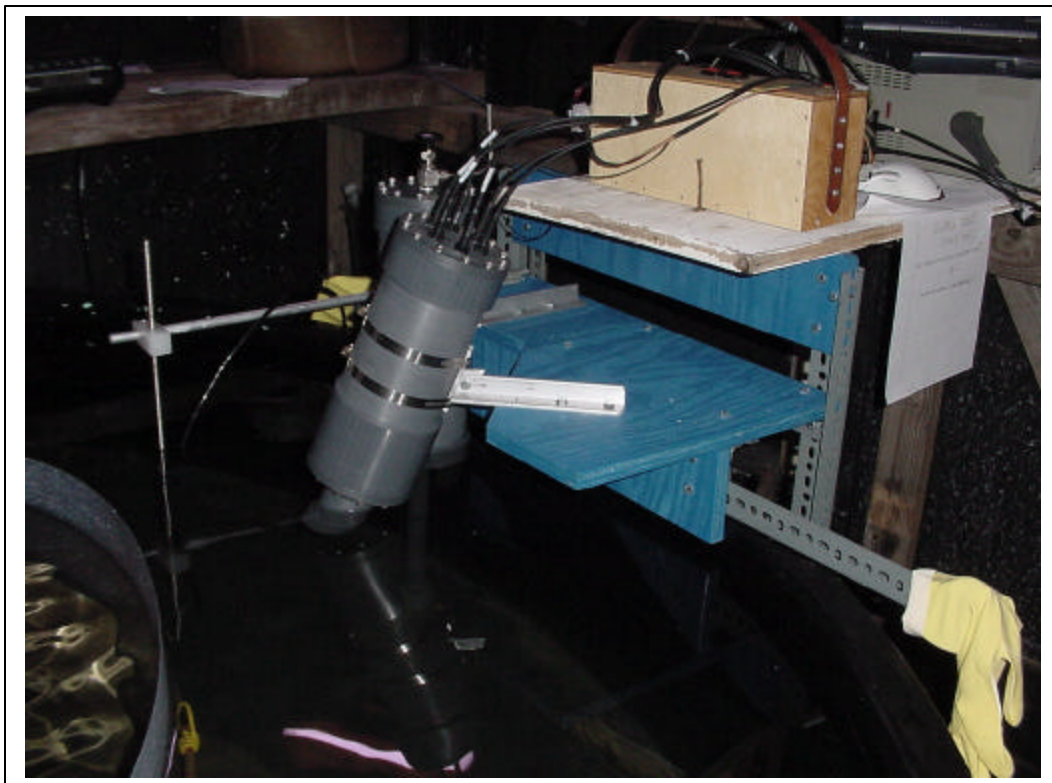

Figure 2: Test Apparatus Mounted in Flow Tank.

The test apparatus, mounted in an annular circulating seawater flow tank, is shown in Figure 2. The seawater was passed through a sand filter to remove larger particles, and a trolling motor initiated the flow. A $\lambda = 650\text{nm}$ ribbon pair was projected a few centimeters above the bottom, and light scattered from a volume element about 30 cm from the nearest instrumental surface was imaged through a narrow band filter onto a photomultiplier. To compare the results with an independent velocity measurement a Marsh-McBirney velocimeter was mounted several centimeters downstream from the observed volume element. The modulation frequencies of the two beams were 40kHz and 50kHz. A notch filter removed the 10kHz beat frequency and a further low pass filter removed the remainder of the modulation signal. The scattered signal bandwidth in each channel after demodulation is greater than 1kHz. A typical ten second trace of the signals from the two channels after demodulation are shown in Figure 3a. These audio frequency signals are digitized by a PCMCIA card (or a sound card) in a laptop “at the surface”

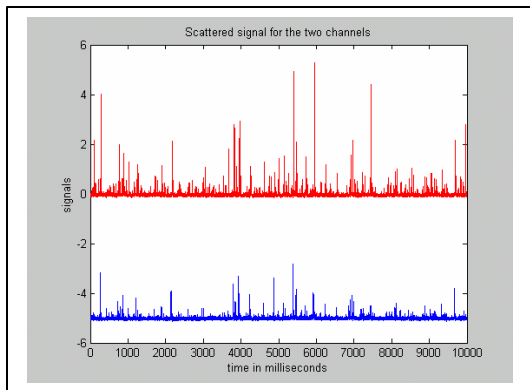

Figure 3a: Typical Scattered Signal From the Two Channels, $S_1(t)$ and $S_2(t)$. Ten Second Trace.

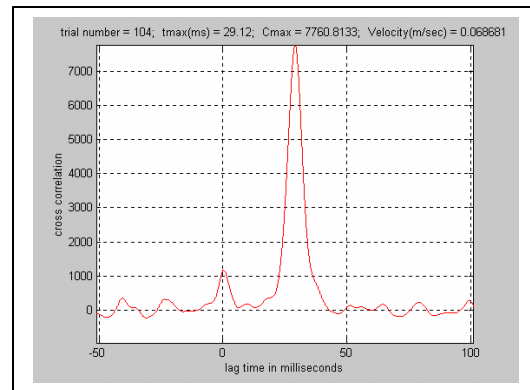

Figure 3b: Cross Correlation of $S_1(t)$ and $S_2(t)$. Delay, $t_d = 29\text{ms}$. Given $d = 2\text{mm}$, $V_x = 6.9\text{ cm/s}$.

and read into a MATLAB program that evaluates and displays the cross correlation function, as shown in Figure 3b. The calculation and display “overhead” is about 0.25s for 5s data. While it is not possible to sort out which pulses on the two signals correspond to a given particle in the raw data, after shifting the data in one channel by the mean cross correlation delay it is pretty straightforward. An example from the same trace is shown in Figure 4 below. It is now easy to

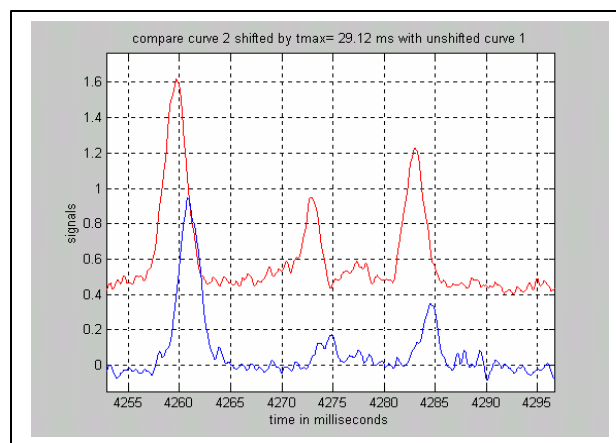

Figure 4: Detail from Time Shifted Trace.

identify pulse pairs, and to see that the local delay in this .040s interval differs from the average 29 ms delay by a few milliseconds. Thus the time resolution upon reanalysis could be as high as the transit time between the two beams. The data taken with the trolling motor running gave measurements of velocities as high as 0.4m/s, which were in fairly good agreement with measurements by the roughly co-located Marsh-McBirney instrument. This was reasonable given the turbulent nature of the driven flow. Turning off the motor and letting the flow smoothly “spin down” provided much better agreement. An example of such a sequence is shown in Figure 5. The lower right hand figure (d) shows a shifted one-second segment of

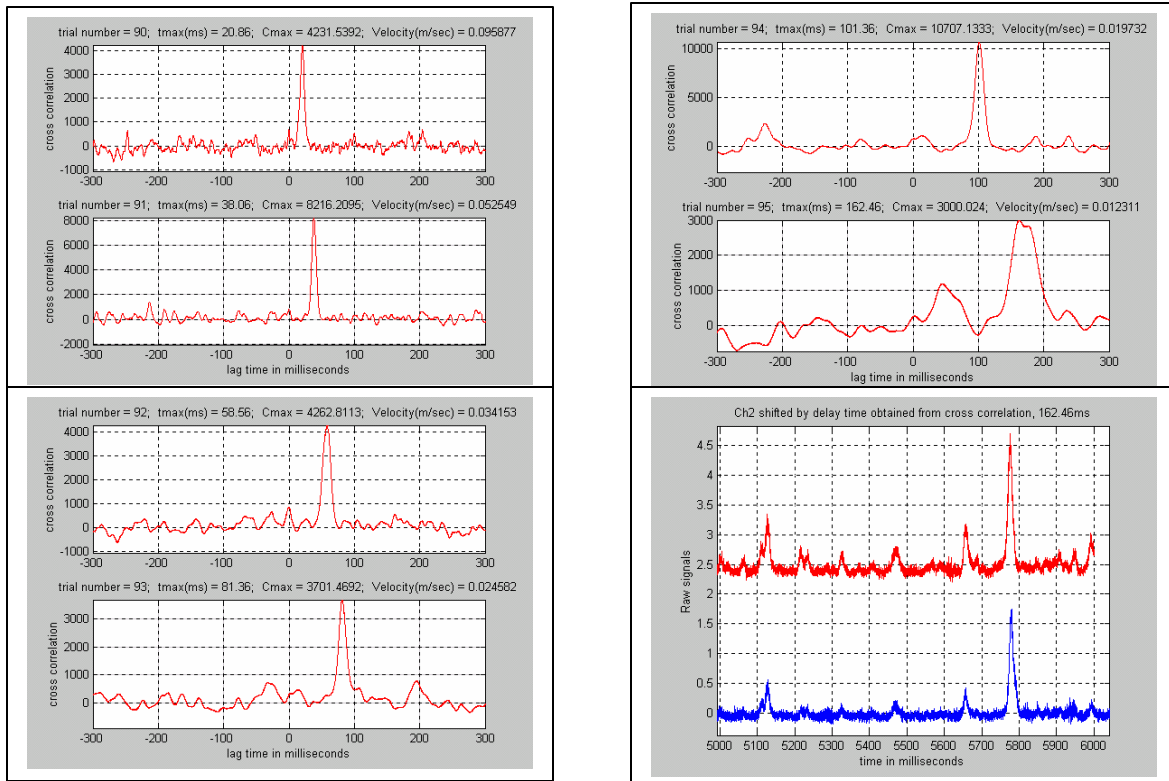

Figure 5a-c: Spindown Sequence.

5d: One Second Segment of Lowest Velocity Trace.

the lowest velocity trace. It indicates that it is possible to identify pulses corresponding to single particles on both traces, even at this slow speed (162 ms inter-beam transit time). It also indicates that not all particles cross both beams in the imaged volume. A comparison with velocity measurements by the nearby Marsh-McBirney instrument during a spin-down sequence demonstrated very good agreement. It appears, therefore, that the instrument is quite capable of accurately measuring the velocity in a remote volume element located just above the bottom.

The next question is: What might we learn about the suspended sediment at the same time? It turns out that, at least under the conditions studied, we can learn quite a bit. Since we already know the velocity, let's concentrate on the scattered light from a single beam. From earlier figures, e.g., 4 and 5d, it is pretty clear that a particular scattered light signal is comprised of pulses of approximately the same width but different amplitudes. The pulse width, however, varies from one curve to the next- low velocities give wide pulses and high velocities give narrow pulses. This is reasonable if the particle is small with respect to the width of the beam.

The amplitude as it moves through the beam will simply map out the beam intensity profile. One way to quantify this behavior is to compute the autocorrelation function for each curve, as shown in Figure 6a. As a function of time the functions are widely different, but if, as shown in Figure 6b, the amplitudes are normalized and the time axes are scaled by dividing by the inter-beam transit time it is clear that the result falls onto a universal curve. If we assume that the pulses are gaussian and that the interbeam spacing is that measured in the laboratory (2mm), it is simple to show that the full 1/e width of the beam is 280mm. This is actually somewhat wider than the value measured in air, and the spreading presumably comes from scattering. This indicates one of the advantages of this method-it is quite tolerant of isotropic scattering in the medium.

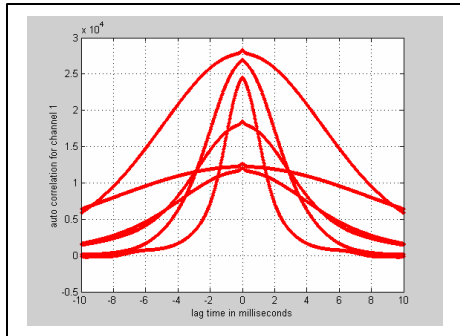

Figure 6a: Auto Correlation Function for Various Velocities.

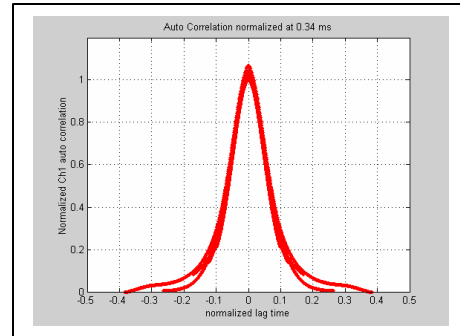

Figure 6b: Normalized Functions Scaled by Dividing Time by the Transit Time Between Beams.

The most interesting feature of the data is that, while all pulses have roughly the same width, there is a very large variation in pulse heights. It is quite reasonable to assume that the pulse height (or, equivalently, the pulse area) is related to the size of the scattering particle, most likely to its area. Thus we wanted to see if we could find an efficient way of extracting the pulse height distribution (PHD) from the signal record. The method we are using begins by assuming that the individual pulses are gaussian, all of the same width, and finding that width from the autocorrelation function. Next this standard pulse is cross-correlated with the actual signal. This

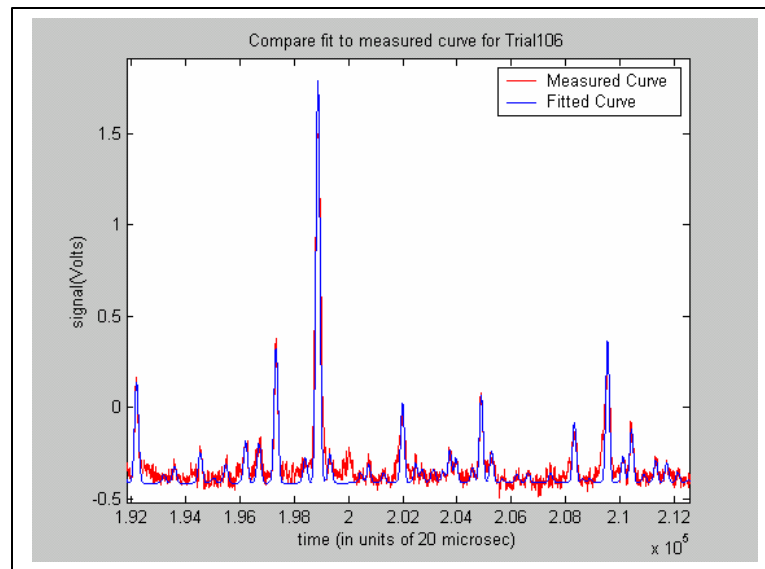

Figure 7: Comparison of Measured Signal to the Fitted Curve Described in the Text.

has the effect of smoothing the signal and allowing us to find the heights and locations of the peaks. The fitted curve can now be calculated. An example comparing the signal (red) and the curve fit in this way (blue) is shown in Figure 7 above. It was intended that this curve should become the starting point for some more rigorous least square fitting routine, but in fact, the fit already seems fairly good. Consequently, we used this method directly in the comparisons below. Its advantage was that it was pretty fast - the overhead to evaluate the PHD for a ten second trace was typically about ten seconds.

In order to compare our PHD's with another measure of the sediment size distribution we grabbed a water sample at roughly the same time and place as our measurement and measured its particle size distribution with a remotely located Coulter counter. A comparison of our PHD with such a Coulter counter measurement is shown in Figure 8. They are internally consistent in

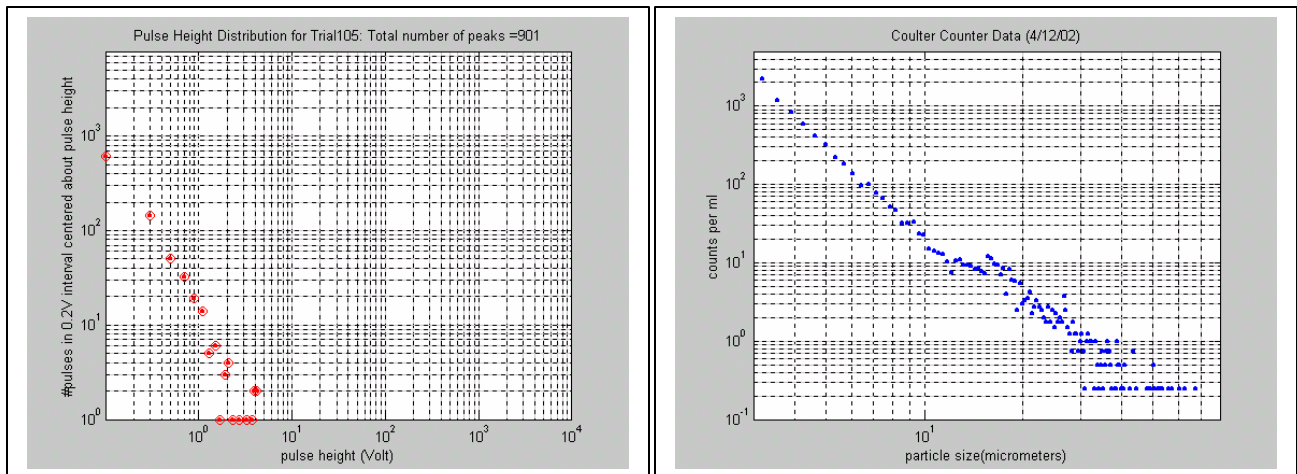

Figure 8: Comparison of PHD (left) with Coulter Counter Particle Size Distribution (right).

showing a power law dependence. The powers are also consistent with the PHD being proportional to the area, but the data aren't particularly conclusive. The main question of interest here is: What is the typical size range of the particles we are observing as distinguishable pulses? This can be inferred from data given in Table I.

Table I: Pulse Height Statistics for Several Curves During a Spin-down Sequence.

Trial #	Total Counts	Velocity (cm/s)	Swept Vol(cm ³)	Particles/cm ³
103	2214	14.88	190.5	11.6
104	1090	6.87	87.9	12.4
105	901	5.99	76.7	11.7
106	900	4.75	60.8	14.8
107	154	0.74	9.47	16.3

The number of pulses resolved ranges from 2214 for the highest velocity trace to 154 for the lowest velocity. Because the volume swept is much greater for the former than for the latter, however, the measured density of particles is much the same, ~15 particles/cm³. This is quite

reasonable, since it is unlikely that the suspended particle distribution would change much between these measurements. We can now integrate the Coulter counter measurements to find that the distribution contained ~ 15 particles/cm³ whose size was greater than 30-35 μ m. Thus a reasonable inference is that we were resolving pulses from particles whose size is ≥ 30 -35 μ m. This is not a resolution limit, however. It is more likely that it characterizes the distribution studied – we will most likely resolve the largest particles in any $\sim r^{-k}$ distribution.

CONCLUSIONS

The apparatus described above was designed to demonstrate the feasibility of the method in one dimension and was roughly optimized for tidal velocities, a relatively low sediment load, and an observation region quite distant from the device. Within these restrictions, we believe it has performed remarkably well. It remains to be seen how well the present instrument will function when these restrictions are relaxed. One must recognize that the method is much more general than the present instrument, however, and could be applied in situations in which the sediment load and velocity are significantly higher or lower than those studied here. Parameters such as the frequencies, the optical pattern, and the overall geometry of the device might need to be altered, but the method would remain the same. Probably the most significant extension would be to study flow in higher dimensions. This may be accomplished simply by adding additional beam pairs, modulated at different frequencies and phases, nominally orthogonal to the first pair.

REFERENCES

- Agrawal, Y. C. and D. G. Aubrey, “*Velocity Observations Above a Rippled Bed Using Laser Doppler Velocimetry*”, J. Geophys. Res. 97, 20249 (1992)
- Bertuccioli, L., G. I. Roth, J. Katz, and T. R. Osborn. “*Turbulence measurements in the bottom boundary layer using Particle Image Velocimetry*”, J. Atmos. Ocean. Technol. 16, 1635 (1999)
- Betteridge, K. F. E., P. D. Thorne, and P. S. Bell, “*Assessment of Acoustic Coherent Doppler and Cross-Correlation Techniques for Measuring Near-Bed Velocity and Suspended Sediment Profiles in the Marine Environment*”, J. Atmos. Oceanic Technol. 19, 367 (2002).
- Creed, E. L., A. M. Pence, and K. L. Rankin, “*Inter-comparison of Turbidity and Sediment Concentration Measurements from an ADP, an OBS-3, and a LISST*”, Oceans 2001, MTS/IEEE Proceedings Vol III, p1750, Holland Publications, Escondito, CA (2001).
- Downing, J. P., R. W. Sternberg, and C. R. B. Lister, “*New instrumentation for the investigation of sediment suspension processes in the shallow marine environment*”, Mar. Geol., 42, 19 (1981)
- Hay, A. E. and J. Sheng, “*Vertical Profiles of Suspended Sand Concentration and Size From Multifrequency Acoustic Backscatter*”, J. Geophys. Res. 97, 15661 (1992).
- Osborne, P. D., C. E. Vincent, and B. Greenwood, “*Measurement of suspended sand concentrations in the nearshore: field intercomparison of optical and acoustic backscatter sensors*”, Continental Shelf Research 14, 159 (1993)
- Traykovski, P., R. Latter, J.D. Irish, “*A Laboratory Evaluation of the LISST Instrument Using Natural Sediments*”, Mar. Geol. 159: 355(1999)
- Voulgaris, G. and J. H. Trowbridge, “*Evaluation of the Acoustic Doppler Velocimeter (ADV) for Turbulence Measurements*”, J. Atmos. Oceanic Technol. 15, 272 (1998).