

Turbo Trellis Coded Modulation with Iterative Decoding for Mobile Satellite Communications

D. Divsalar and F. Pollara

Jet Propulsion Laboratory, California Institute of Technology

4800 Oak Grove Dr., Pasadena, CA911 09

Phone: 818-354-4287 FAX: 818-354-6825

email: dariush@shannon.jpl.nasa.gov

Abstract— In this paper, analytical bounds on the performance of parallel concatenation of two codes, known as turbo codes, and serial concatenation of two codes over fading channels are obtained. Based on this analysis, design criteria for the selection of component trellis codes for MPSK modulation, and a suitable bit-by-bit iterative decoding structure are proposed. Examples are given for throughput of 2 bits/sec/Hz with 8PSK modulation. The parallel concatenation example uses two rate 4/5 8-state convolutional codes with two interleaves. The convolutional codes outputs are then mapped to two 8PSK modulations. The serial concatenated code example uses an 8-state outer code with rate 4/5 and a 4-state inner trellis code with 5 inputs and 2x8PSK outputs per trellis branch. Based on the above mentioned design criteria for fading channels, a method to obtain the structure of the trellis code with maximum diversity is proposed. Simulation results are given for AWGN, and independent Rayleigh fading channel with perfect Channel State Information (CSI).

I. INTRODUCTION

Trellis coded modulation (TCM) proposed by Ungerboeck in 1982 [1] is now a well-established technique in digital communications. Since its first appearance, TCM has generated a continuously growing interest, concerning its theoretical foundations as well as its numerous applications, spanning high-rate digital transmission over voice circuits, digital microwave radio relay links, and satellite communications. In essence, it is a technique to obtain significant coding gains (3-6 dB) sacrificing neither data rate nor bandwidth.

Turbo codes represent a more recent development in the coding research field [2], which has raised large interest in the coding community. They are *parallel concatenated convolutional codes* (PCCC) whose encoder is formed by two (or more) *constituent* systematic encoders joined through one or more interleaves. The input information bits feed the first encoder and, after having been scrambled by the interleaver, they enter the second encoder. A codeword of a parallel concatenated code consists of the input bits to the first encoder followed by the parity check bits of both encoders. Analytical performance bounds for PCCC with uniform interleaver and maximum likelihood receiver were obtained in [3], and [6] for AWGN channel, and in [16] for Rayleigh fading channel with binary modulation.

The (suboptimal) iterative decoding structure [15] is modular, and consists of a set of concatenated decoding modules, one for each constituent code, connected through the same

The research described in this paper was carried out at the Jet Propulsion Laboratory, California Institute of Technology, under contract with the National Aeronautics and Space Administration

interleaves used at the encoder side. Each decoder performs weighted soft decoding of the input sequence. Bit error probabilities as low as 10^{-6} at $E_b/N_0 = -0.6$ dB have been shown by simulation [11] using codes with rates as low as 1/15. Parallel concatenated convolutional codes yield very large coding gains (10-11 dB) at the expense of a data rate reduction, or bandwidth increase.

In [4] we merged TCM and PCCC in order to obtain large coding gains and high bandwidth efficiency. In [14] and [13] we suggested to merge TCM with the recently discovered serial concatenated convolutional codes (SCCC) [12], adapting the concept of iterative decoding used in parallel concatenated codes. We refer to the concatenation of an outer convolutional code with an inner TCM as serial concatenated TCM (SCTCM).

For parallel concatenated trellis coded modulation (PCTCM), also addressed as “turbo TCM”, a first attempt employing the so-called “pragmatic” approach to TCM was described in [5]. Later, turbo codes were embedded in multilevel codes with multistage decoding [7]. Recently [8], punctured versions of Ungerboeck codes were used to construct turbo codes for 8-PSK modulation. In [4] a different approach to construct PCTCM was proposed. Results in [4] show that the performance of the proposed codes is within 1 dB from the Shannon limit at bit error probabilities of 10^{-7} over AWGN channels.

In this paper we used turbo trellis coded modulation and serial trellis coded modulation as discussed above, over fading channels for mobile satellite communications. For fading channel, we assume Rayleigh fading. Rician fading is actually a better model for mobile satellite communications since there is LOS (line-of-sight), but when an omnidirectional antenna is used and LOS is blocked by trees, poles, or buildings Rayleigh fading can be used as a worst-case scenario.

II. ANALYTICAL BOUNDS ON THE PERFORMANCE OF CODES OVER FADING CHANNELS

Consider an (n, k) block code C with code rate $R_c = k/n$ and minimum distance d_{min} . An upper bound on the conditional bit-error probability of the block code C over fading channel, assuming coherent detection, maximum likelihood decoding, and perfect Channel State Information (CSI) can

be obtained in the form

$$* P_b(e|\rho) \leq \sum_{h=d_{min}}^n \sum_{w=1}^k \frac{w}{k} A_{w,h}^C Q \left(\sqrt{2R_c E_b/N_0 \sum_{i=1}^h \rho_i^2} \right) \quad (1)$$

where E_b/N_0 is the signal-to-noise ratio per bit, and $A_{w,h}^C$ for the block code C represent the number of codewords of the block code with output weight h associated with an input sequence of weight w . $A_{w,h}^C$ is the input-output weight coefficient (IOWC). The Q function can be represented as [17]

$$Q(x) = \frac{1}{\pi} \int_0^{\frac{\pi}{2}} e^{-\frac{x^2}{2 \sin^2 \theta}} d\theta \leq 0.5 e^{-\frac{x^2}{2}} \quad (2)$$

To obtain the unconditional bit error rate, we have to average over the joint density function of fading samples. For simplicity assume independent Rayleigh fading samples. This assumption is valid if we use an interleaver after the encoder and a **deinterleaver** before the decoder. Thus the fading samples ρ_i are i.i.d. random variables with Rayleigh density of the form

$$f(\rho) = 2\rho e^{-\rho^2}$$

By averaging the conditional bit error rate over fading we obtain

$$P_b(e) \leq \frac{1}{\pi} \int_0^{\frac{\pi}{2}} \sum_{h=d_{min}}^n \sum_{w=1}^k \frac{w}{k} A_{w,h}^C \left[\frac{\sin^2 \theta}{\sin^2 \theta + R_c E_b/N_0} \right]^h d\theta \quad (3)$$

We can further upper bound the above result and obtain

$$P_b(e) \leq \sum_{h=h_m}^n \sum_{w=1}^k \frac{w}{k} A_{w,h}^C \left[\frac{1}{1 + R_c E_b/N_0} \right]^h \quad (4)$$

Extension of results to independent **Rician** fading is straightforward (see for example [10]). All these results apply to convolutional codes as well, if we construct an equivalent block code from the convolutional code. Obviously results apply also to concatenated codes including parallel and serial concatenations. As soon as we obtain the input-output weight coefficients $A_{w,h}^C$ for a particular code we can compute the performance.

III. PARALLEL CONCATENATED CONVOLUTIONAL CODES

The structure of a parallel concatenated convolutional code (PCCC) or ‘‘turbo code’’ is shown in Fig. 1. It refers to the case of two convolutional codes, code C_1 with rate $R_c^1 = p/q_1$, and code C_2 with rate $R_c^2 = p/q_2$, where the constituent code inputs are joined by an interleaver of length N , generating a PCCC, C_p , with rate $R_c = \frac{R_c^1 R_c^2}{p^1 + p^2}$. Note that N is an integer multiple of p . The input block length $k = N$, and the output codeword length $n = n_1 + n_2$ as shown in Fig. 1.

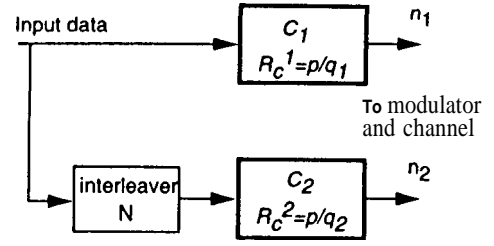

Fig. 1, Parallel Concatenated Convolutional Codes (PCCC).

A. Computation of input-output weight coefficient (IOWC) $A_{w,h}^{C_p}$ for PCCC (turbo codes)

Uniform Interleaver. A crucial step in the analysis of concatenated codes and in particular PCCC consists of replacing the actual interleaver that performs a permutation of the N input bits with an abstract interleaver called a uniform **interleaver** [3], defined as a probabilistic device that maps a given input word of weight w into all distinct (\sim) permutations of it with equal probability $p = 1/\binom{k}{w}$.

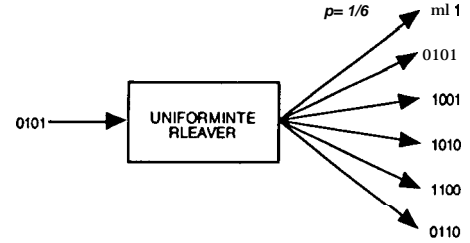

Fig. 2. The action of a uniform interleaver of length 4 on sequences of weight 2

Using the concept of uniform interleaver, i.e., averaging the $P_b(e)$ over all possible interleaves, we can obtain $A_{w,h}^{C_p}$ for turbo codes.

With the knowledge of the $A_{w,h_1}^{C_1}$ for code C_1 , and $A_{w,h_2}^{C_2}$ for code C_2 , using the concept uniform interleaver, IOWC $A_{w,h}^{C_p}$ for PCCC can be obtained as follows. The main property of the uniform interleaver is that it transforms an input block of weight w at the input of the encoder C_1 into all its distinct ($\binom{k}{w}$) permutations, As a consequence, each input block of code C_1 of weight w , through the action of the uniform interleaver, enters the encoder C_1 generating (\sim ,) input-words of code C_2 . Thus, the number $A_{w,h_1,h_2}^{C_p}$ of codewords of the PCCC with output weights h_1 , and h_2 associated with an input sequence of weight w is given by

$$A_{w,h_1,h_2}^{C_p} = \frac{A_{w,h_1}^{C_1} \times A_{w,h_2}^{C_2}}{\binom{k}{w}}$$

where $A_{w,h_1,h_2}^{C_p}$ is related to $A_{w,h}^{C_p}$ as

$$A_{w,h}^{C_p} = \sum_{h_1+h_2=h} A_{w,h_1,h_2}^{C_p}$$

Example 1. Consider a rate 1/2 PCCC formed by two identical 4-state convolutional codes: Code C_1 with rate 2/3 and code C_2 with rate 1/1 (this is obtained by not sending the systematic bits of the rate 2/3 C_2 convolutional code). The inputs are joined by a uniform interleaver of length $N = 50, 100$ and 256. Both codes are systematic and recursive, and are shown in Fig. 3. Using the previously outlined analysis for PCCC, we have obtained the bit-error probability bounds shown in Fig. 3. The performance is shown both for AWGN and Rayleigh fading channels.

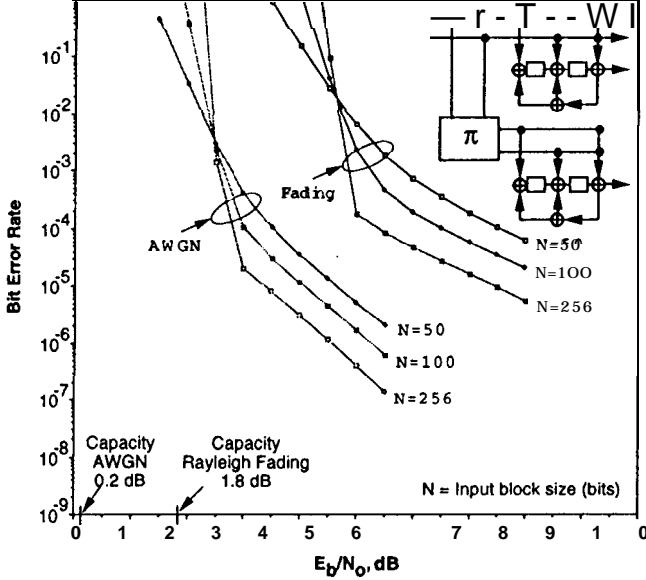

Fig. 3. Performance of rate 1/2 PCCC over AWGN and Rayleigh Fading Channel

The reason for such a good performance of turbo codes is that the coefficients $\frac{A_{w,h}^{C_P}}{N}$ decrease with interleaver size. For large interleaves the maximum component of $\frac{A_{w,h}^{C_P}}{N}$ or equivalently $\frac{A_{w,h}^{C_P}}{N}$, over all input weights w and output weights h , and h_2 , is proportional to N^{α_M} , with corresponding output weights $h_1(\alpha_M)$, and $h_2(\alpha_M)$. If both convolutional codes are recursive (i.e., the output weight due to input weight one is very large) then $\alpha_M \leq -1$ (This occurs for $w = 2$). Any other choice of encoders results in $\alpha_M \geq 0$. When α_M is negative we say that we have “interleaving gain”. The negative value of α_M implies that the exponents of N in the bit error rate expression are always negative integers. Thus, for all $h = h_1 + h_2$, the coefficients of the exponents in h decrease with N , and we always have an *interleaving gain* [9].

Define $d_{i,f,eff}$ as the minimum weight of codewords of a recursive code C_i , $i = 1, 2$ generated by weight-2 input sequences. We call it the effective free Hamming distance of a recursive convolutional code. To maximize the *interleaving gain*, i.e., minimize N^{α_M} corresponding to output weight $h_1(\alpha_M)$, and $h_2(\alpha_M)$ we should maximize the $d_{i,f,eff}$, $i = 1, 2$. The sum $d_{1,f,eff} + d_{2,f,eff}$ represents the effective free distance of the turbo code [9] [11]. Thus, substituting

the exponent α_M into the expression for bit error rate approximated by keeping only the term of the summation in h_1 , and h_2 corresponding to $h = h_1(\alpha_M)$, and $h_2 = h_2(\alpha_M)$, yields

$$\lim_{N \rightarrow \infty} P_b(e) \simeq BN^{-1} \left[\frac{1}{[1 + R_c \frac{E_b}{N_0}]^{d_{1,f,eff} + d_{2,f,eff}}} \right] \quad (5)$$

where B is a constant independent of N .

IV. Parallel Concatenated Trellis Coded Modulation

The basic structure of parallel concatenated trellis coded modulation is shown in Fig. 4,

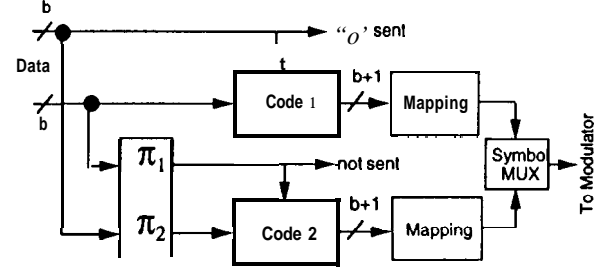

Fig. 4. Block Diagram of the Encoder for Parallel Concatenated Trellis Coded Modulation.

This structure uses two rate $\frac{2b}{2b+1}$ constituent convolutional codes. The first most significant output bits of each convolutional code are only connected to the shift register of the TCM encoder and are not mapped to the modulation signals. The last $b+1$ least significant output bits however are mapped to the modulation signals. This method requires at least two interleaves. The first interleaver permutes the b least significant input bits. This interleaver is connected to the b most significant bits of the second TCM encoder. The second interleaver permutes the b most significant input bits. This interleaver is then connected to the b least significant bits of the second TCM encoder.

A. Design Criteria for PCTCM over Rayleigh Fading Channels

To extend the asymptotic results we obtained for binary modulation to M -ary Modulation (e.g. MPSK), let x_i represent the sequence of M -ary output symbols $\{x_{i,j}\}$ of trellis code i ($i = 1, 2$), with unit power. Let x'_i represent another sequence of the output symbols $\{x'_{i,j}\}$ for $i = 1, 2$. Then the above asymptotic result should be modified to

$$P_b(e) \simeq BN^{-1} \prod_{n_1 \in \eta_1} \left[\frac{1}{[1 + |x_{1,n_1} - x'_{1,n_1}|^2 R_c \frac{E_b}{4N_0}]} \right] \times \prod_{n_2 \in \eta_2} \left[\frac{1}{[1 + |x_{2,n_2} - x'_{2,n_2}|^2 R_c \frac{E_b}{4N_0}]} \right]$$

where, for $i = 1, 2$, η_i is the set of all n_i with the smallest cardinality $d_{i,f,eff}$ such that $x_{i,n_i} \neq x'_{i,n_i}$. Then $d_{i,f,eff}$ represents the minimum (M -ary symbol) Hamming distance of

trellis code i ($i = 1, 2$) corresponding to input Hamming distance 2 between binary input sequences that produce $d_{i,f,eff}$. The $d_{i,f,eff}, i = 1, 2$ is also called minimum diversity of trellis code i . We note that the asymptotic result on the bit error rate is inversely proportional to the product of the squared Euclidean distances along the error event paths which result in $d_{i,f,eff}, i = 1, 2$. Therefore the criterion for optimization of the component trellis codes is to maximize the minimum diversity of the code and then maximize the product of the squared Euclidean distances which result in minimum diversity.

B. 2 bits/sec/Hz PCTCM with 8PSK for AWGN and Fading Channels

The code we propose has $b = 2$, and employs 8PSK modulation in connection with two 8-state, rate 4/5 constituent codes. The selected code uses reordered mapping: If b_2, b_1, b_0 represents a binary label for natural mapping for 8PSK, where b_2 is the MSB and b_0 is the LSB, then the reordered mapping is given by $b_2, (b_2 + b_1), b_0$. The effective Euclidean distance of this code is $\delta_{f,eff}^2 = 5.17$ (unit-norm constellation is assumed), using two interleaves.

The structure of this code is shown in Fig. 5, and its BER for AWGN and Rayleigh fading channel in Fig. 6.

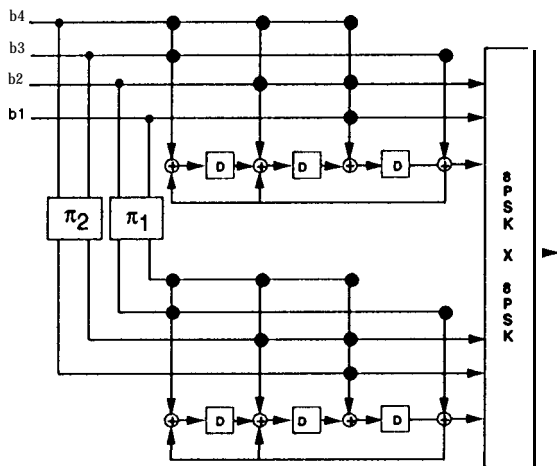

Fig. 5. Parallel Concatenated Trellis Coded Modulation. 8PSK, 2 bits/sec/Hz,

V. SERIALLY CONCATENATED CONVOLUTIONAL CODES

The structure of a serially concatenated convolutional code (SCCC) is shown in Fig. 7. It refers to the case of two convolutional codes, the outer code C_o with rate $R_o^c = q/p$, and the inner code C_i with rate $R_i^c = p/m$, joined by an interleaver of length N bits, generating an SCCC with rate $R_c = k/n$. Note that N must be an integer multiple of p . The input block size is $k = Nq/p$ and the output block size of SCCC is $n = Nm/p$.

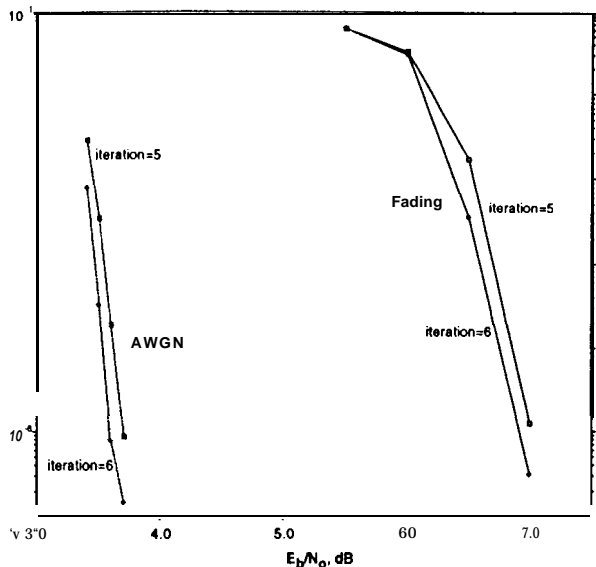

Fig. 6. BER Performance of Parallel Concatenated Trellis Coded 8PSK, 2 bits/sec/Hz,

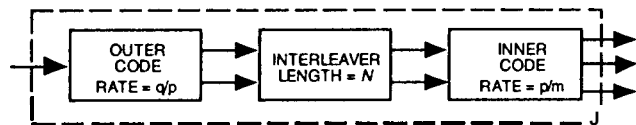

Fig. 7. Serially Concatenated Convolutional Codes (SCCC).

A. Computation of input-output weight coefficient (IOWC) $A_{w,h}^{C_s}$ for SCCC

Using the concept of uniform interleaver, i.e., averaging $P_b(e)$ over all possible interleaves, we can obtain $A_{w,h}^{C_s}$ for serial concatenated codes. $A_{w,h}^{C_s}$ is the number of codewords of the SCCC with weight h associated with an input word of weight w . A similar definition applies to input-output weight coefficients (IOWC) of the outer code denoted by $A_{w,l}^{C_o}$ and to IOWC of the inner code denoted by $A_{l,h}^{C_i}$.

With the knowledge of the $A_{w,l}^{C_o}$ for the outer code, $A_{l,h}^{C_i}$ for the inner code, and using the concept of uniform interleaver, the IOWC $A_{w,h}^{C_s}$ for SCCC can be obtained as follows. We recall that a uniform interleaver transforms a codeword of weight l at the output of the outer encoder into all its distinct $\binom{N}{l}$ permutations. As a consequence, each codeword of the outer code C_o of weight l , through the action of the uniform interleaver, enters the inner encoder generating $\binom{N}{l}$ codewords of the inner code C_i . Thus, the number $A_{w,h}^{C_s}$ of codewords of the SCCC of weight h associated with an input word of weight w is given by

$$A_{w,h}^{C_s} = \sum_{l=0}^N \frac{A_{w,l}^{C_o} \times A_{l,h}^{C_i}}{\binom{N}{l}}$$

Example 2. Consider a rate 1/2 SCCC formed by a 4-state

convolutional code C_o with rate $1/2$ and an inner 2-state convolutional code C_i with rate $1/1$ (this is obtained by not sending the systematic bits of the rate $1/2$ C_i convolutional code). The two codes are joined by a uniform interleave. Input blocks of length $N = 50, 100$ and 256 were considered. The outer code is a **nonrecursive** code, the inner code is systematic and recursive, and the generators are shown in Fig.8. Using the previously outlined analysis for SCCC, we have obtained the bit-error probability bounds shown in Fig.8. The performance was obtained both for AWGN and Rayleigh fading channels. Comparing to Fig. 3, the performance of SCCC is better than PCCC both over AWGN and fading channels.

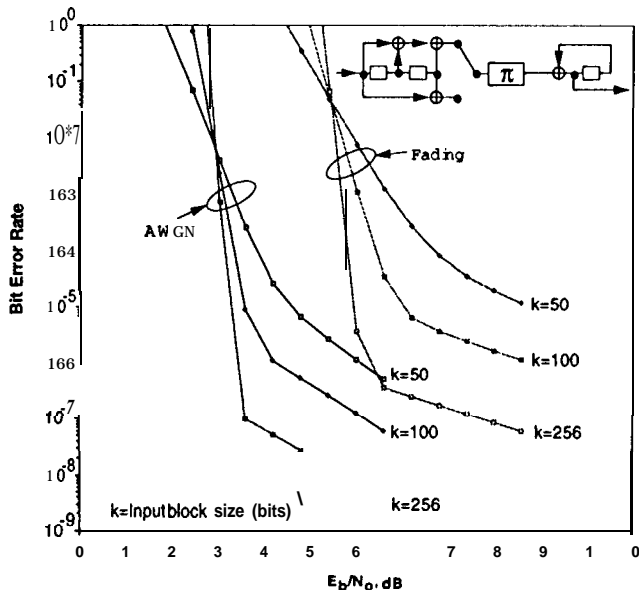

Fig. 8. Performance of rate $1/2$ SCCC over AWGN and Rayleigh Fading Channel

For large interleaves the maximum component of $\frac{A_{w,h}^{C_s}}{N}$ over all input weights w , and output weights h is proportional to N^{α_M} with corresponding output weights $h(\alpha_M)$. If the inner convolutional code is recursive (i.e., with feedback) then $\alpha_M = -\frac{d_f^o + 1}{2}$ where d_f^o is the free (minimum) distance of the outer convolutional code.

The value of α_M shows that the exponents of N are always negative integers. Thus, for all h , the coefficients of the exponents in h decrease with N , and we always have an "interleaving gain".

Define $d_{f,eff}^i$ as the minimum weight of codewords of the inner code generated by weight-2 input sequences. We obtain a different weight $h(\alpha_M)$ for even and odd values of d_f^o . For even d_f^o , the weight h (&&f) associated to the highest exponent of N is given by

$$h(\alpha_M) = \frac{d_f^o d_{f,eff}^i}{2}$$

Substituting the exponent α_M into the expression for bit error rate, approximated by only the term of the summation in h

corresponding to $h = h(\alpha_M)$, yields

$$\lim_{N \rightarrow \infty} P_b(e) \simeq B_{even} N^{d_f^o/2} \left[\frac{1}{1 + R_c \frac{E_b}{N_0}} \right]^{\frac{d_f^o d_{f,eff}^i}{2}} \quad (6)$$

where B_{even} is a constant independent of N .

For d_f^o odd, the value of $h(\alpha_M)$ is given by

$$h(\alpha_M) = \frac{(d_f^o - 3)d_{f,eff}^i}{2} + h_m^{(3)} \quad (7)$$

where $h_m^{(3)}$ is the minimum weight of sequences of the inner code generated by a weight-3 input sequence.

Thus, substituting the exponent α_M into the expression for bit error rate approximated by keeping only the term of the summation in h corresponding to $h = h(\alpha_M)$ yields

$$\lim_{N \rightarrow \infty} P_b(e) \simeq B_{odd} N^{-(d_f^o + 1)/2} \left[\frac{1}{1 + R_c \cdot I} \right]^{\frac{(d_f^o - 3)d_{f,eff}^i}{2} + h_m^{(3)}} \quad (8)$$

where B_{odd} is a constant independent of N .

VI. Serial Concatenated Trellis Coded Modulation

The basic structure of serially concatenated trellis coded modulation is shown in Fig. 9.

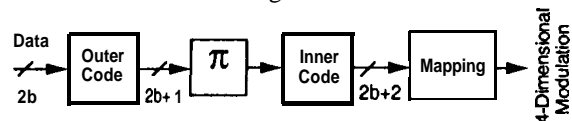

Fig. 9. Block Diagram of the Encoder for Serial Concatenated Trellis Coded Modulation.

We propose a novel method to design serial concatenated TCM for Rayleigh fading channels, which achieves b bits/see/Hz, using a rate $2b/(2b+1)$ non-recursive binary convolutional encoder with maximum free Hamming distance as outer code. We interleave the output of the outer code with a random permutation. The interleaved data enters a rate $(2b+1)/(2b+2)$ recursive convolutional inner encoder. The $2b+2$ output bits are mapped to two symbols belonging to a 2^{b+1} level modulation (four dimensional modulation). In this way, we are using $2b$ information bits for every two modulation symbol intervals, resulting in b bit/see/Hz transmission (when ideal Nyquist pulse shaping is used) or, in other words, b bits per modulation symbol. For AWGN channel the inner code and the mapping is jointly optimized based on maximizing the effective Euclidean distance of the inner TCM. The optimum 2-state inner trellis code is shown in Fig. 10. The effective Euclidean distance of this code is 1.76 (for unit norm constellation) and its minimum M-ary Hamming distance is 1.

A. Design Criteria for SCTCM over Rayleigh Fading Channels

To extend the asymptotic results obtained for binary modulation to M-ary modulation (e.g., MPSK), criteria similar to those discussed for parallel concatenated trellis coded

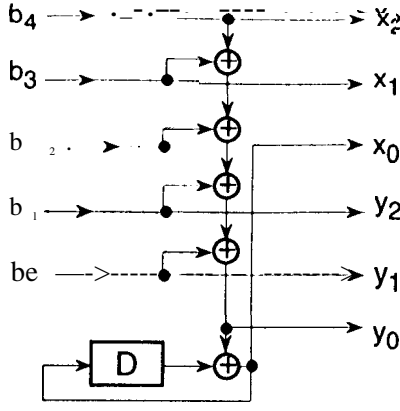

Fig. 10. Optimum 2-state inner trellis encoder for SCTCM with 2x 8PSK Modulation,

modulation (PCTCM) are now applied to serial concatenated trellis coded modulation (SCTCM). The interleaving gain is still $(d_f^o)^{1/2}$, however now the minimum diversity is $\frac{d_f^o d_{f,eff}^o}{2}$ for even d_f^o , and $\frac{(d_f^o-3)d_{f,eff}^o}{2} + h_m^{(3)}$ for odd d_f^o , where $d_{f,eff}^o$ represent the minimum (M-ary symbol) Hamming distance of the inner trellis code corresponding to input Hamming distance 2 between binary input sequences to the trellis code that produce $d_{f,eff}^o$. Therefore the criterion for optimizing the inner trellis code in SCTCM is to maximize the minimum diversity of the code and then maximize the product of the squared Euclidean distances which result in minimum diversity. For odd d_f^o , first we maximize $d_{f,eff}^o$, then among the codes with maximum $d_{f,eff}^o$, we maximize $h_m^{(3)}$ the minimum (M-ary symbol) Hamming distance of the inner trellis code corresponding to input Hamming distance 3 between binary input sequences to the trellis code that produce $h_m^{(3)}$. As it is seen from the previous results, large d_f^o produces large interleaving gain and diversity.

B. Design Method for Inner TCM

The proposed design method is based on the following steps:

1. The well known set partitioning techniques for Rayleigh fading channels using multidimensional signal sets are used (see for example [10] and the references therein).
2. The input labels assignment is based on the codewords of the parity check code $(2b+1, 2b, 2)$ and its set partitioning, to maximize the quantities described in the design criteria subsection.

The assignment of codewords of the parity check code to the 4-dimensional signal points is not arbitrary.

We would like somehow to relate the Hamming distance between input labels to the Euclidean distance between corresponding 4-dimensional signal points, under the constraint that the minimum Hamming distance between input labels for parallel transitions be equal to 2. To do so:

Assign the b most significant bits of the input label to the first constellation with 2^{b+1} points by retaining only the b most significant bits of the Gray code mapping for the constellation. Use the same assignment for the b least significant bits of the input labels; The middle bit in the input label represents the overall parity check bit.

3. A sufficient condition to have very large output Euclidean and M-ary symbol Hamming distances for input sequences with Hamming distance 1, is that all input labels to each state be distinct,
4. Assign pairs of input labels and 4-dimensional signal points to the edges of a trellis diagram based on the design criteria in subsection A.

To illustrate the design methodology we developed the following examples.

C. Examples of the Design Methodology

Example 1: Set partitioning of 2x8PSK and input labels assignment.

Let the eight phases of 8PSK be denoted by $\{0, 1, 2, 3, 4, 5, 6, 7\}$. Consider the 2x8PSK signal set $A_0 = [(0, 0), (1, 3), (2, 6), (3, 1), (4, 4), (5, 7), (6, 2), (7, 5)]$. Each element in the set has two components. The second component is 3 times the first one modulo 8. Also consider the 2x 8PSK signal set $B_0 = [(0, 0), (1, 5), (2, 2), (3, 7), (4, 4), (5, 1), (6, 6), (7, 3)]$. Each element in the set has two components. The second component is 5 times the first one modulo 8. The Hamming distance between elements in each set is 2, the minimum of the product of square Euclidean distances is maximum.

The following sets are constructed from A_0 and B_0 as: $A_2 = A_0 + (0, 2)$, $A_4 = A_0 + (0, 4)$, $A_6 = A_0 + (0, 6)$, $A_1 = B_0 + (0, 1)$, $A_3 = B_0 + (0, 3)$, $A_5 = B_0 + (0, 5)$, $A_7 = B_0 + (0, 7)$, where addition is component-wise modulo 8. Map the first and last 2 bits of input labels to the 8PSK signals as $\{00, 00, 01, 01, 11, 11, 10, 10\} \Rightarrow \{0, 1, 2, 3, 4, 5, 6, 7\}$.

The fifth bit for the input label is the parity check bit. Use even parity check bit for signal sets A_0, A_2, A_4, A_6 and odd parity check for signal sets A_1, A_3, A_5, A_7 . This completes the input label assignments to signal sets.

Now the Hamming distances of input labels for each set $A_i, i=0, 1, 2, \dots, 7$, is at least 2 and the corresponding M-ary Hamming distances between signal elements in each set is 2. Consider a 4-state trellis code with full transition. Assign A_0, A_2, A_4, A_6 to the first state, and A_1, A_3, A_5, A_7 to the second state, and permutations of these sets to the third and fourth states. This completes the input label and 2x8PSK signal set assignments to the edges of 4-state trellis. The minimum Hamming distance of code is 2. At this point to obtain a circuit that generates this trellis we need to use an output label. We used reordered mapping as it was used before to obtain the circuit for the encoder.

The implementation of the 1-state inner trellis code is

shown in Fig. 11. The ROM maps addresses in the range (0) to 31 to a single output. The 32 binary outputs can be summarized in hex as 3A53ACC5

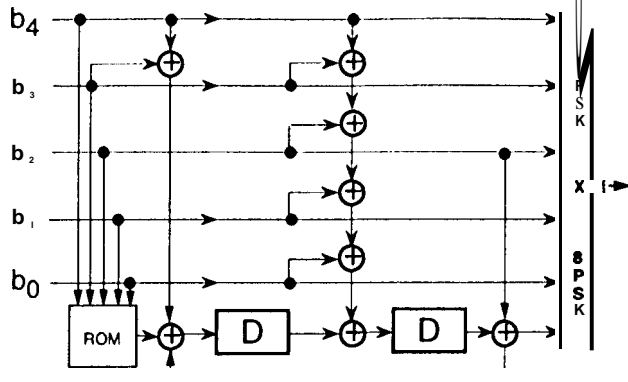

Fig. 11. 4-state inner trellis encoder for SCTCM with 2x8PSK modulation for Rayleigh fading.

VII. Simulation of Serial Concatenated Trellis Coded Modulation with Iterative Decoding

In this section the simulation results for serial concatenated TCM, with 2 x 8PSK over Rayleigh fading channel is presented. For SCTCM with 2x 8PSK, the outer code is a rate 4/5, 8-state nonrecursive convolutional encoder with $d_f^o = 3$, and the inner code is a 4-state TCM designed for 2 x 8PSK in the previous section. The bit error probability vs. bit signal-to-noise ratio E_b/N_o for various number of iterations is shown in Fig. 12. The performance of inner 2-state code is also shown in Fig. 12. This example demonstrates the power and bandwidth efficiency of SCTCM, over Rayleigh fading channel at low BERs.

REFERENCES

- [1] G. Ungerboeck, "Channel coding with multilevel phase signaling", *IEEE Trans. Inf. Th.*, vol. IT-25, pp.55-67, Jan. 1982.
- [2] C. Berrou, A. Glavieux, and P. Thitimajshima, "Near Shannon Limit Error-Correcting Coding: Turbo Codes," *Proc. 1993 IEEE International Conference (m Communications, Geneva, Switzerland*, pp. 1064-1070, May 1993.
- [3] S. Benedetto and G. Montorsi, "Unveiling turbo codes: some results on parallel concatenated coding schemes", *IEEE Trans. on Inf. Theory*, March 1996.
- [4] S. Benedetto, D. Divsalar, G. Montorsi, and F. Pollara, "Parallel Concatenated Trellis Coded Modulation", proceedings of ICC'96, June 1996.
- [5] S. LeGoff, A. Glavieux, and C. Berrou, "Turbo Codes and High Spectral Efficiency Modulation", *Proceedings of IEEE ICC '94*, May 1-5, 1994, New Orleans, LA.
- [6] D. Divsalar, S. Dolinar, R. J. McEliece, and F. Pollara, "Transfer Function Bounds on the Performance of Turbo Codes." *The Telecommunications and Data Acquisition Progress Report 42-122, April-June /1995*, Jet Propulsion Laboratory, Pasadena, California, pp. 44-55, August 15, 1995.
http://edms-www.jpl.nasa.gov/tda/progress_report/42-122/122A.pdf
- [7] L. U. Wachsmann, and J. Huber, "Power and Bandwidth Efficient Digital Communication Using Turbo Codes in Multilevel Codes," *Euro-*

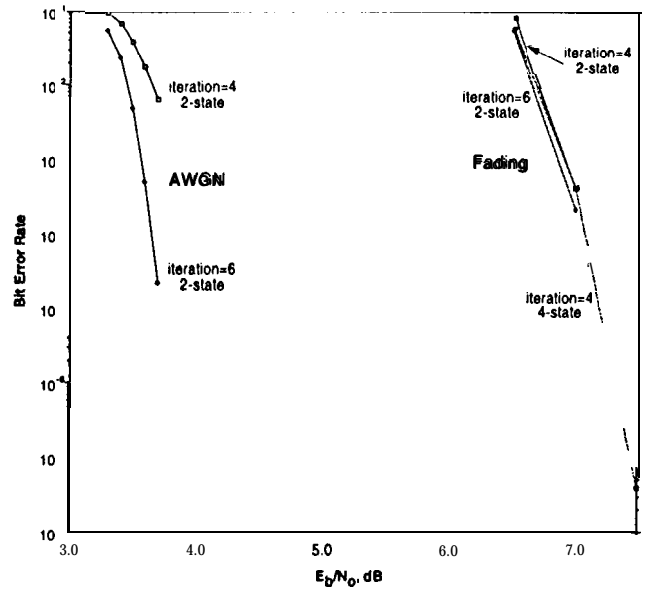

Fig. 12. Performance of Serial Concatenated Trellis Coded Modulation, 8-state outer 2-state or 4-state inner with 2x8PSK, 2 bits/see/Hz

pean Transactions on Telecommunications, vol. 6, No. 5, Sept./Oct. 1995, pp. 557-567.

- [8] P. Robertson, and T. Woerz, "Novel Coded modulation scheme employing turbo codes," *Electronics Letters*, 31st Aug. 1995, Vol. 31, No. 18.
- [9] S. Benedetto and G. Montorsi, "Design of Parallel Concatenated Convolutional Codes," *IEEE Transactions on Communications*, vol. 44, no. 5, pp. 591-600, May 1996.
- [10] E. Biglieri, et al, *Introduction to Trellis-Coded Modulation with Applications*, Macmillan 1991.
- [11] D. Divsalar and F. Pollara, "On the Design of Turbo Codes". JPL TDA Progress Report 42-123, Nov 15, 1995.
- [12] S. Benedetto, D. Divsalar, G. Montorsi, and F. Pollara, "Serial Concatenation of Interleaved Codes: Performance Analysis, Design, and Iterative Decoding," *The Telecommunications and Data Acquisition Progress Report 42-126, April-June 1996*, Jet Propulsion Laboratory, Pasadena, California, pp. 1-26, August 15, 1996.
- [13] S. Benedetto, D. Divsalar, G. Montorsi, and F. Pollara, "Serial Concatenated Trellis Coded Modulation with Iterative Decoding: Design and Performance." Submitted to IEEE Comm. Theory Mini Conference 97, (Globecom 97).
- [14] S. Benedetto, D. Divsalar, G. Montorsi, and F. Pollara, "Serial Concatenated Trellis Coded Modulation with Iterative Decoding," IEEE ISIT 97, Ulm, Germany.
- [15] S. Benedetto, D. Divsalar, G. Montorsi, and F. Pollara, "Soft-Output Decoding Algorithms in Iterative Decoding of Turbo Codes." *The Telecommunications and Data Acquisition Progress Report 42-124, October-December /1995*, Jet Propulsion Laboratory, Pasadena, California, pp. 63-87, February 15, 1996.
- [16] E. K. Hall, and S. G. Wilson, "Design and Analysis of Turbo Codes on Rayleigh Fading Channels." JSAC special issue, submitted Sep. 96.
- [17] J. Craig, "A new, simple and exact result for calculating error probability for two-dimensional signal constellation," *Milcom*, 1991.

Return-Path: <landerso@mail1.jpl.nasa.gov>
Return-Path: <landerso@mail1.jpl.nasa.gov>
To: Charlotte Marsh <Charlotte.S.Marsh@jpl.nasa.gov>
From: Louise Anderson <landerso@mail1.jpl.nasa.gov>
Subject: IMSC Conference Proceedings
Date: Tue, 29 Apr 1997 12:20:58 -0700

April 29, 1997

Charlotte--

Can you give me the publication number of the 1997 International Mobile Satellite Conference (IMSC) Proceedings? *

Also, can you tell me if the following five papers for that conference, written by JPL authors, have been submitted for clearance and cleared?

1. "ACTS Mobile Terminals" by Brian S. Abbe, Martin J. Agan, and Thomas C. Jedrey 4/24/96 0296-0699

2. "A Comparative Study of Co-Channel Interference Suppression Techniques," by Jon Hamkins, Ed Satorius, Gent Paporisto, and Andreas Polydoros NOT cleared

Don't have

→ 3. "Low Cost Large Space Antennas," by Artur B. Chmielewski and Robert Freeland NOT cleared

4. "A Metric to Evaluate Mobile Satellite Systems," by Elizabeth L. Young NOT cleared

5. "K/Ka-Band Aeronautical Experiments." by Martin J. Agan, Michael J. Connally, and Thomas C. Jedrey NOT cleared

→ Lastly, can you tell me if a clearance form for the publication as a whole has been submitted, and if the publication has been cleared? has not been submitted* or cleared

Thanks,
Louise

→ A Real-Time Testbed for satellite and Terrestrial Communications Experimentation t, o. w d c y + Q + -
K. Angkasa, J. Hamkins, J. Jao, N. Lay,
E. Satorius, A. Zavallos

OK

Chmielewski
3501
125-121
4-0255
Freeland
125-224
4-3540
354