

XP-811 Results

Vertical Stability - ΔZ_{\max} Measurement

presented by
Egemen Kolemen
For the NSTX Team
at
NSTX ASC Meeting
August 7th, 2008

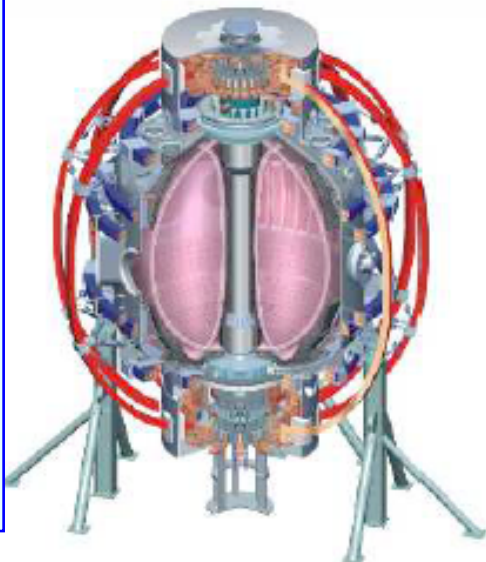

*Culham Sci Ctr
U St. Andrews
York U
Chubu U
Fukui U
Hiroshima U
Hyogo U
Kyoto U
Kyushu U
Kyushu Tokai U
NIFS
Niigata U
U Tokyo
JAEA
Hebrew U
Ioffe Inst
RRC Kurchatov Inst
TRINITY
KBSI
KAIST
ENEA, Frascati
CEA, Cadarache
IPP, Jülich
IPP, Garching
ASCR, Czech Rep*

*College W&M
Colorado Sch Mines
Columbia U
Comp-X
General Atomics
INEL
Johns Hopkins U
LANL
LLNL
Lodestar
MIT
Nova Photonics
New York U
Old Dominion U
ORNL
PPPL
PSI
Princeton U
SNL
Think Tank, Inc.
UC Davis
UC Irvine
UCLA
UCSD
U Colorado
U Maryland
U Rochester
U Washington
U Wisconsin*

Vertical Displacement Measurements

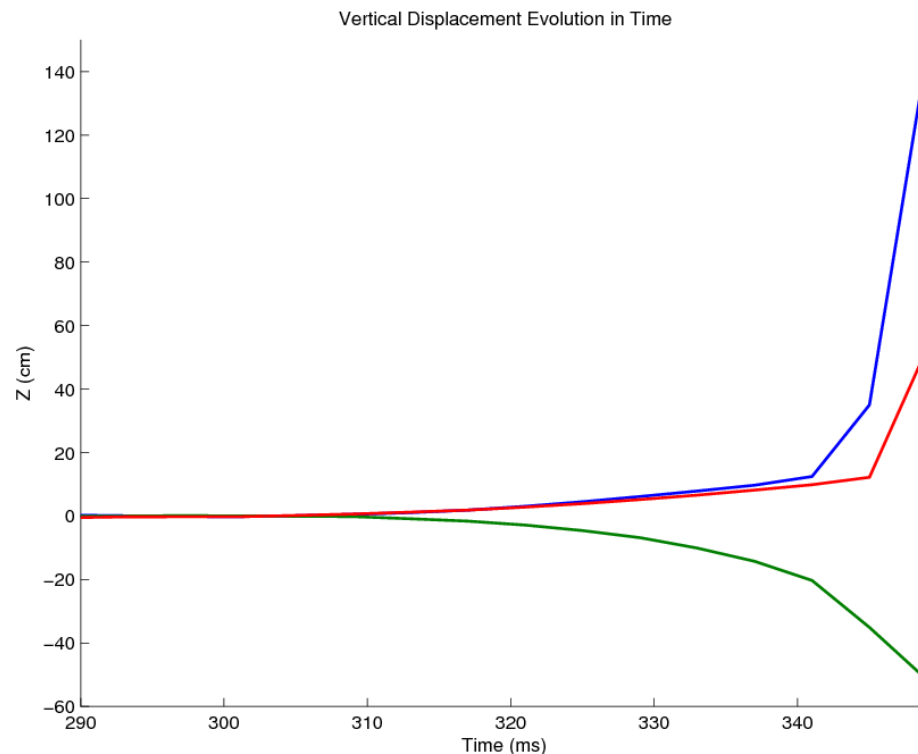
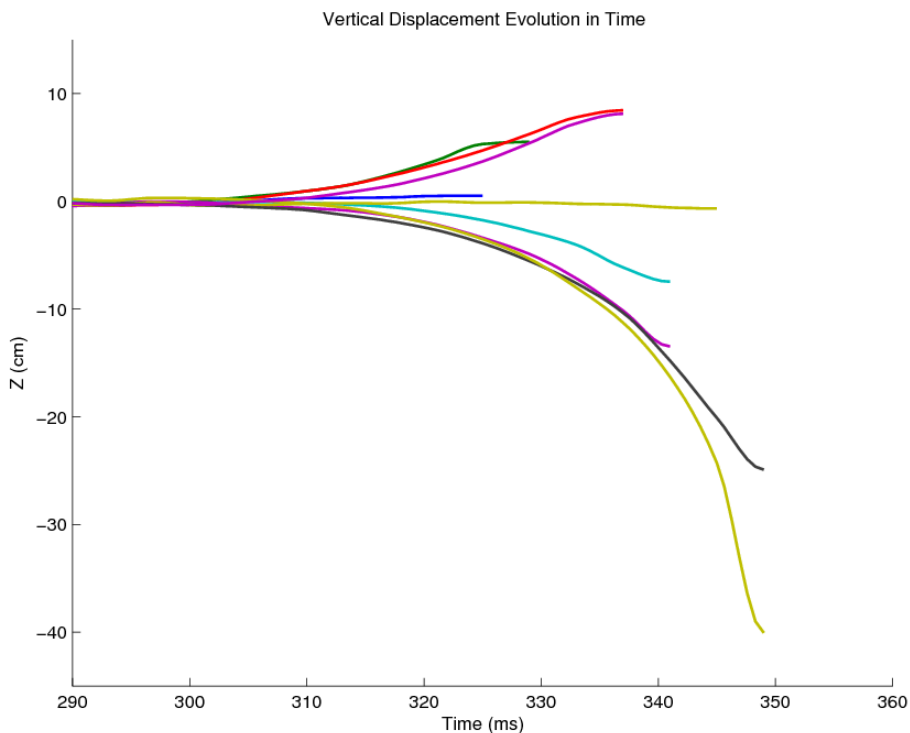

**Vertical displacement for controllable shots
(Cut off at the point of return)**

Vertical displacement for uncontrollable shots

- At 300 ms, we turned the controller off and let the plasma drift.
- When we turned the control back on some of the shots recovered while others hit the wall.

Asymmetry in NSTX Conducting Structure

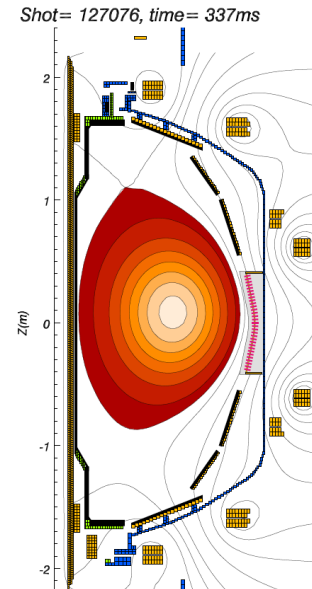
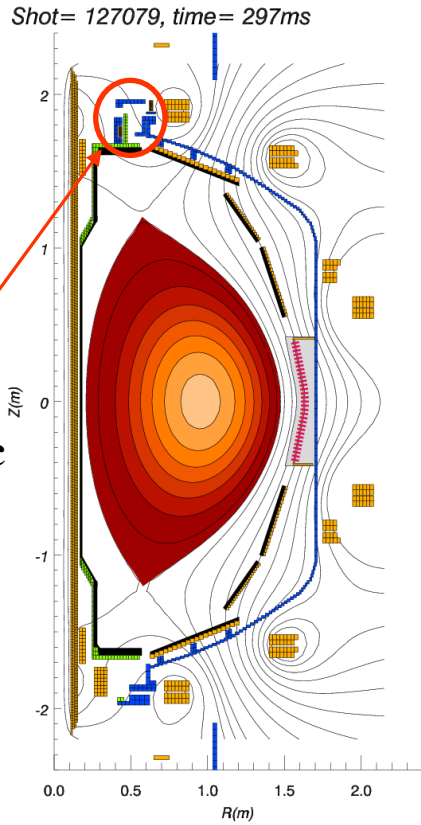

Upward Shape

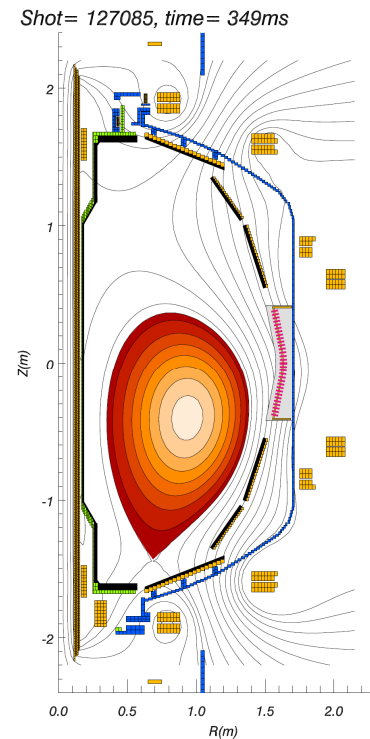

Downward Shape

ΔZ_{\max} for Up and Down Directions

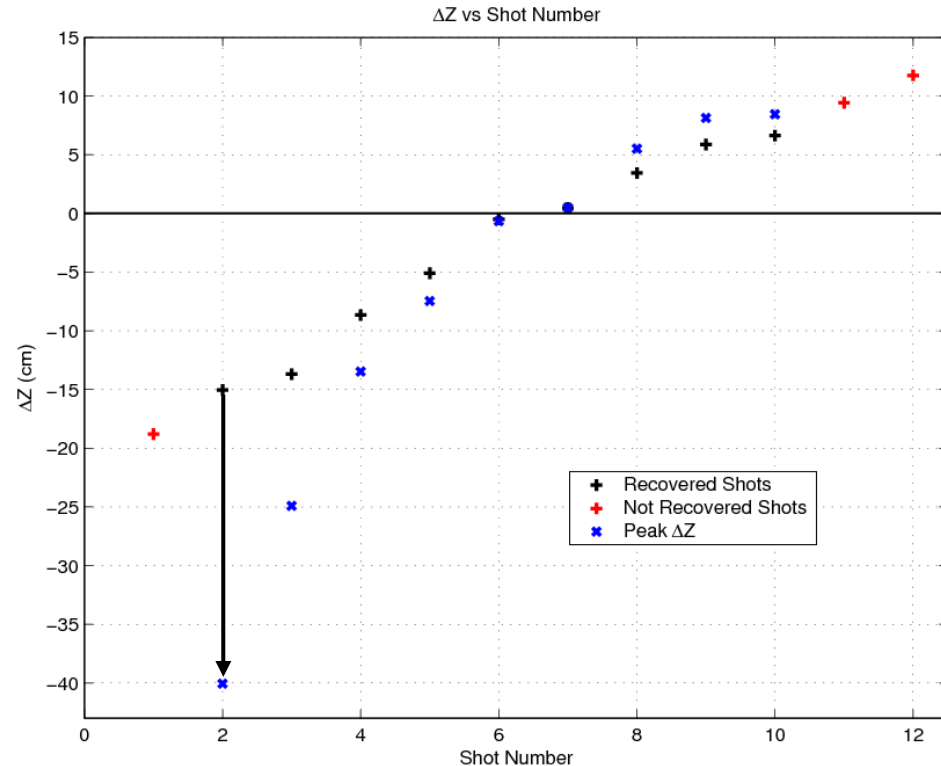
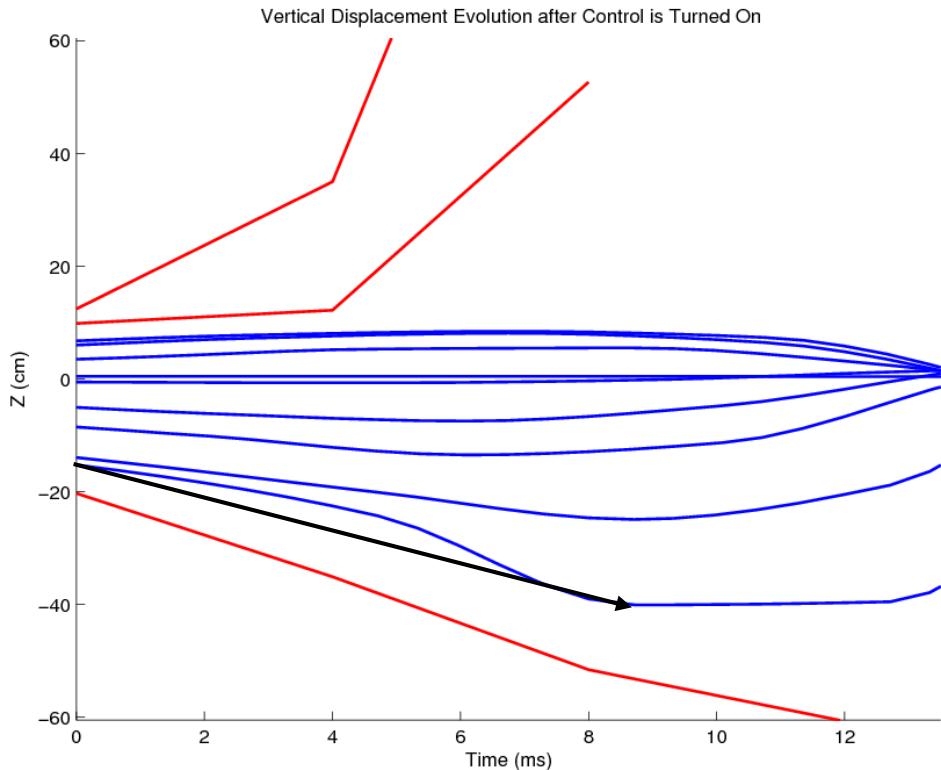

- Red lines show the shots where the vertical displacement was uncontrollable while the blue lines are the controllable ones.
- NSTX is not up/down symmetric (mirror symmetry).
- $\Delta Z_{\max} = 6.6$ cm for upward motion and **15.0** cm for downward.
- $\Delta Z_{\max}/a = 10\%$ for upward motion and **23%** for downward.

Trust Region for Z Calculations

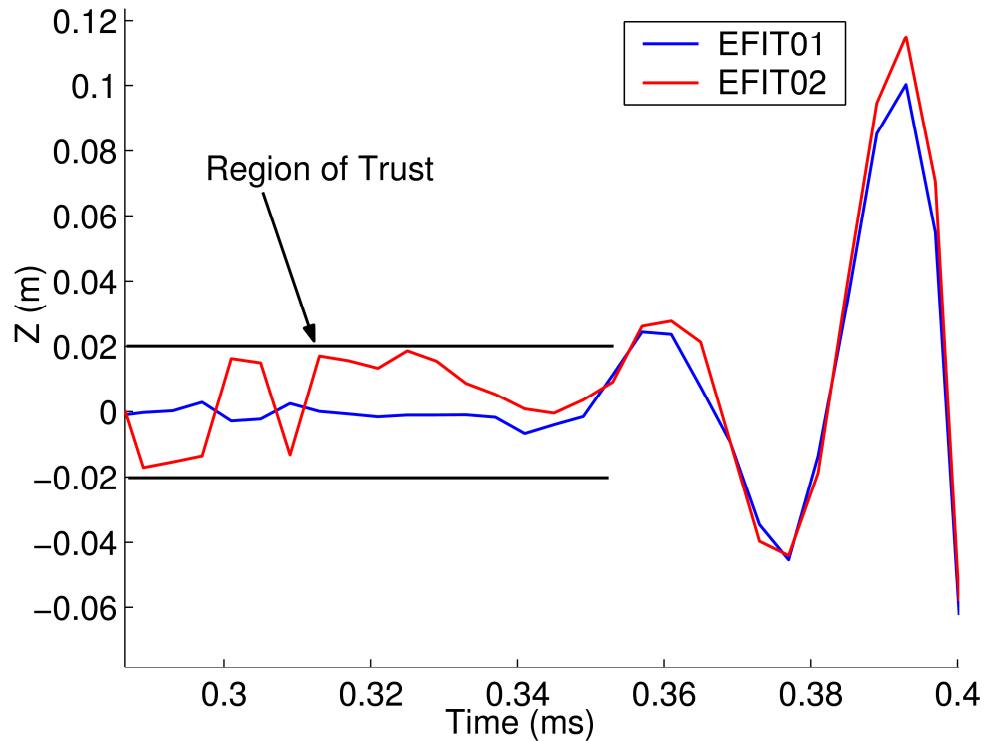

- When the plasma centroid is close to the center of NSTX, Z calculations are correct within ± 2 -3 cm.
- This is a problem for numerical model calculations. Z grows exponentially and small errors lead to unrealistic predictions.

Model Comparison: Growth Rate Mismatch

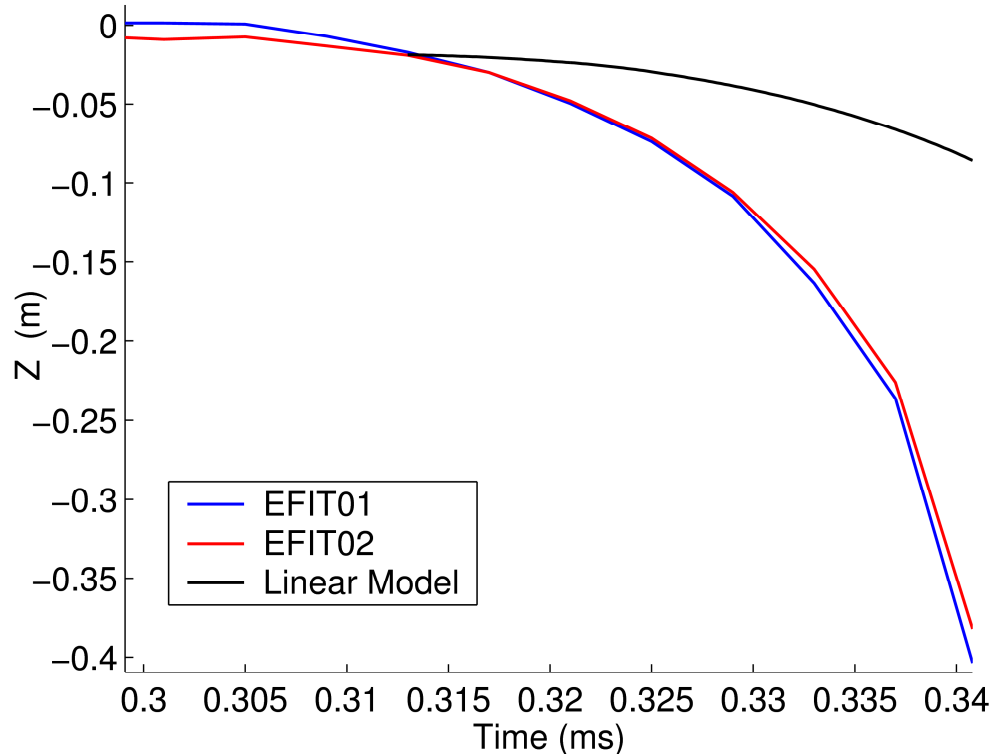

- The numerical simulation is started roughly 10 ms to let the plasma move out of this region.
- There is a mismatch between the experimental growth rate and the numerical calculations. Currently, I am trying to solve this problem.

ADDITIONAL SLIDES

Experiment Run Plan

- The shot numbers in the experiment were 1207064 through 127087.
- In the experiment we used:
 - Helium plasma to keep the density constant, enabling reproducible results.
 - Ohmic discharge.
 - 600 kA current.
 - $B_T \sim 5$ kG
 - $I_i \sim 1.4$
 - Lower, upper gap ~ 45 cm
- Experiment run time was 1 run day.

Measure κ_{\max}

- First measured κ_{\max} – maximum controllability threshold in elongation.
- We increased the elongation starting from 1.8 and determined maximum robustly controllable growth rate.
- Scanned κ values showed that for $\kappa > 1.9$ the plasma is not controllable.
- Continued the ΔZ_{\max} measurement experiment with $\kappa \sim 1.9$.

Measure ΔZ_{\max}

- Second part of the experiment is to measure ΔZ_{\max} – maximum controllable displacement.
 - Set elongation below κ_{\max} to $\kappa=1.9$.
 - Freezed coil commands to disable vertical control for a period to allow VDE.
 - Let the plasma drift for a specific period starting with 20 ms for the first experiment.
 - Restored the coil control command.
 - The control was turned back on with maximum available voltage (slew rate limited).
 - Repeated the experiment with increased drift periods [20, 30, 35, 40, 45, 50] ms.
 - Determined maximum controllable displacement for robust operation.
 - Repeated the experiment many times to get statistically sound data.

Measure ΔZ_{\max} : Consistent Data

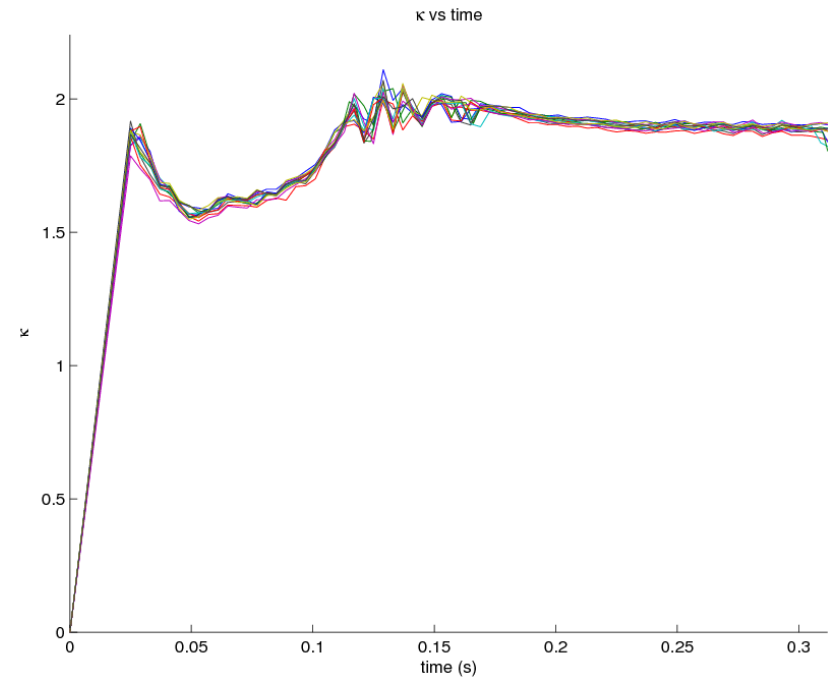
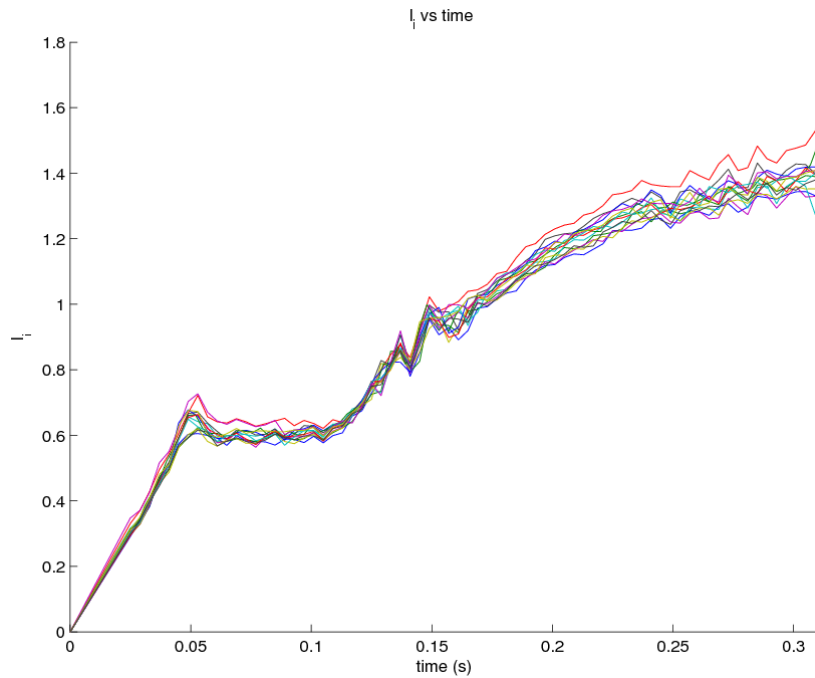

Time evolution of I_i and κ for all the shots before control is turned off

- We were able to repeat the experiment very consistently.

Deciding If the Plasma Recovered or Not

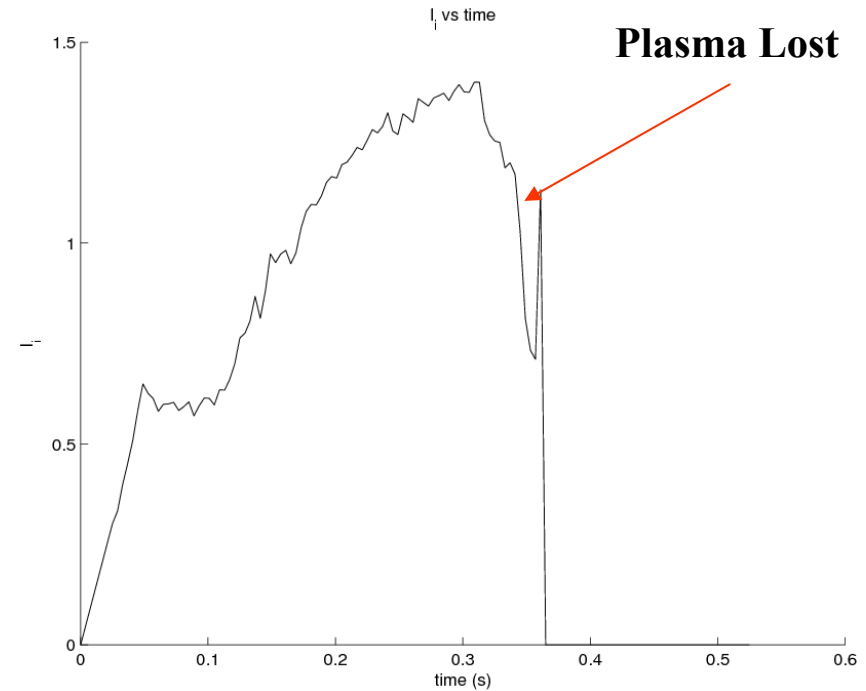
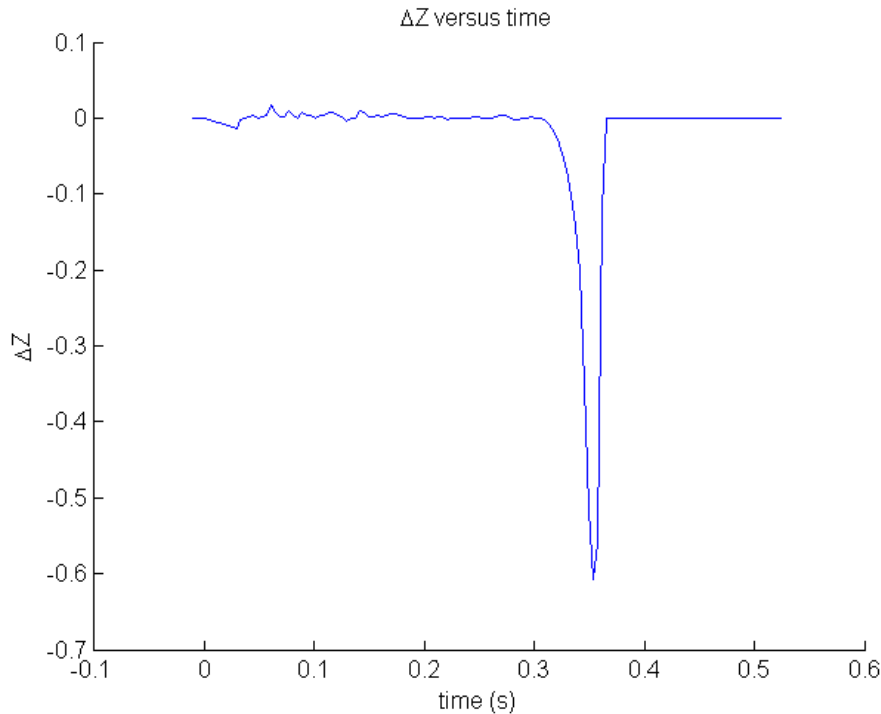

ΔZ and I_t for shot number 127084

- We were able to stop and return the motion of plasma before hitting the wall for the **all downward** vertical displacements.
- But for some of these shots most of the magnetic energy was lost before moving up.
- We considered these shots as not recovered.

Future Work: Model Based Optimal Control

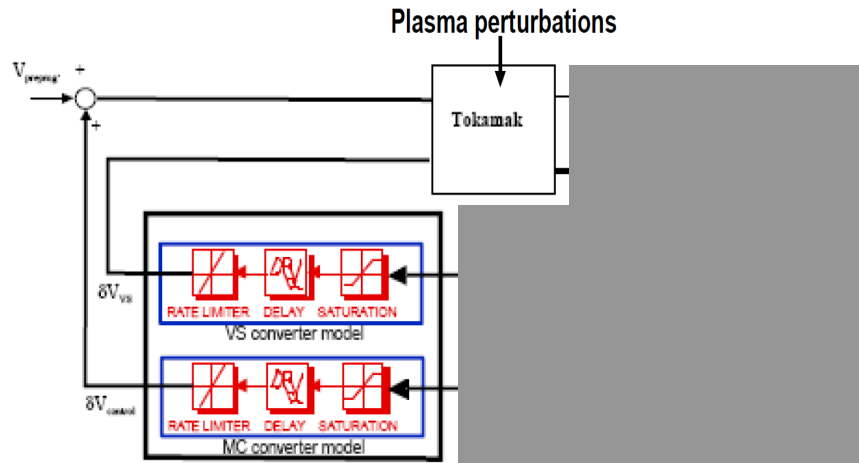

Current Control Method

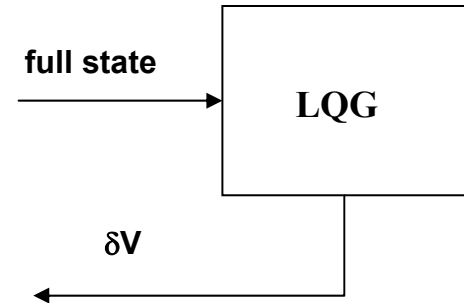

Proposed Optimal Control

- Currently, PID controller is used for the vertical mode control.
- We are developing a **model based optimal control** for the vertical stability.
- **Develop low-dimensional models** of this mode of instability using the simplified models of Hofmann as a starting point.
- Use these models to **design feedback laws** using modern control techniques, such as optimal Linear Quadratic Gaussian (LQG) control.
- The experimental results will help us **validate and tune system models** that will be used for control.

Vertical Growth Rate and Frequency

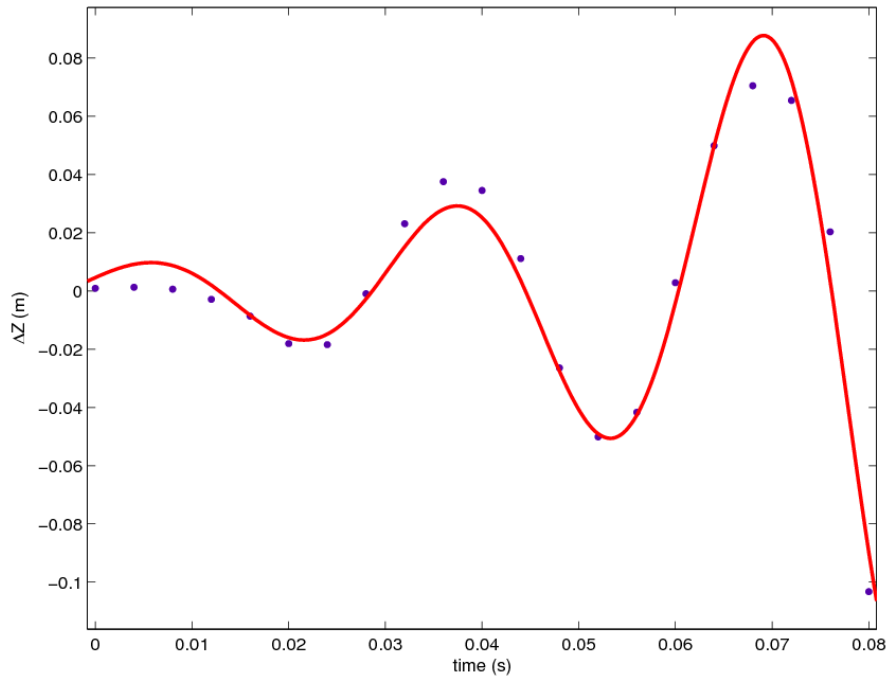

Vertical displacement with control on

- Dynamics of the plasma with controller on were obtained by fitting the unstable data set.
- Vertical motion can be defined by a second order differential equation:

$$\ddot{Z} + a\dot{Z} + b = f(t)$$

with solution:

$$Z = e^{\gamma t} \sin(\omega t + \phi)$$

- $\omega \sim 200 \text{ s}^{-1}$ and $\gamma \sim [35, 95] \text{ s}^{-1}$ based on multiple data fits.
- **Data from the XP will be used to develop and validate low-dimensional models of this mode of instability.**

Conclusion and Future Work: Application to ITER

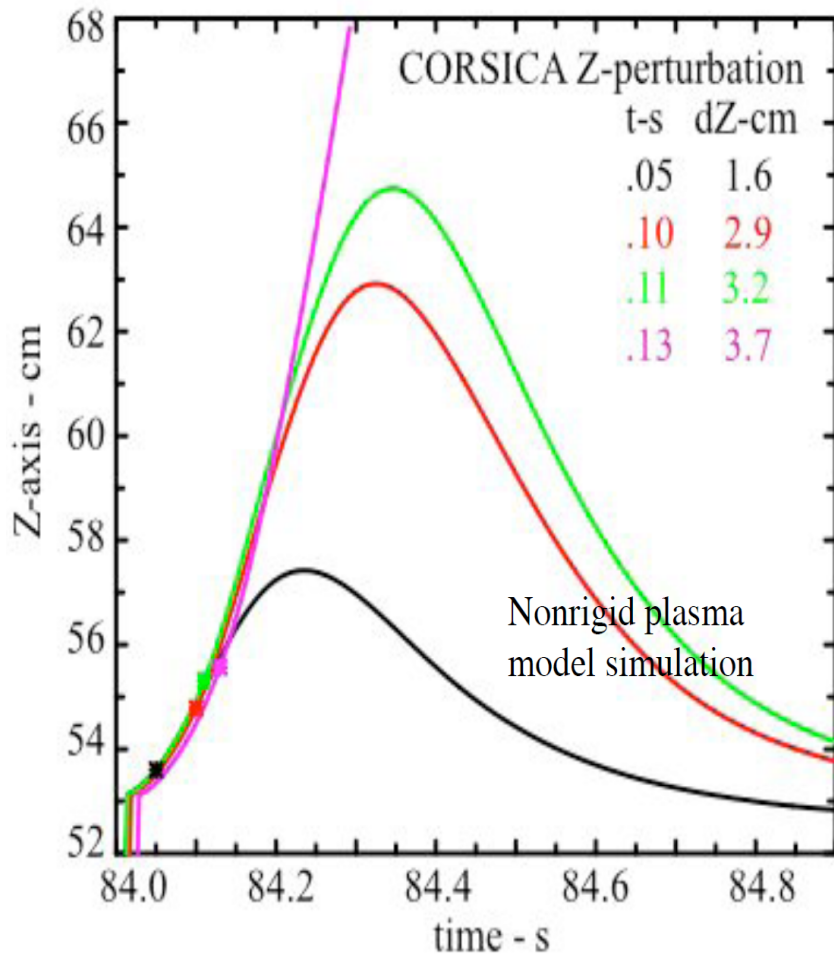

ITER ΔZ_{\max} determination via Corsica numerical simulation

- C-Mod and DIII-D require $\Delta Z_{\max}/a$ %10 or higher for robust control (Recent XP).
- We confirm these results. (Maybe even higher)
- Nonlinear Corsica ITER Simulations Find Maximum Controllable $\Delta Z_{\max} \sim 3.5$ cm ($\Delta Z_{\max}/a \sim 2\%$)
- Future Work: Apply to these models to ITER, to validate design predictions for ITER.

Future Work: Correlation between l_i and ΔZ_{peak}

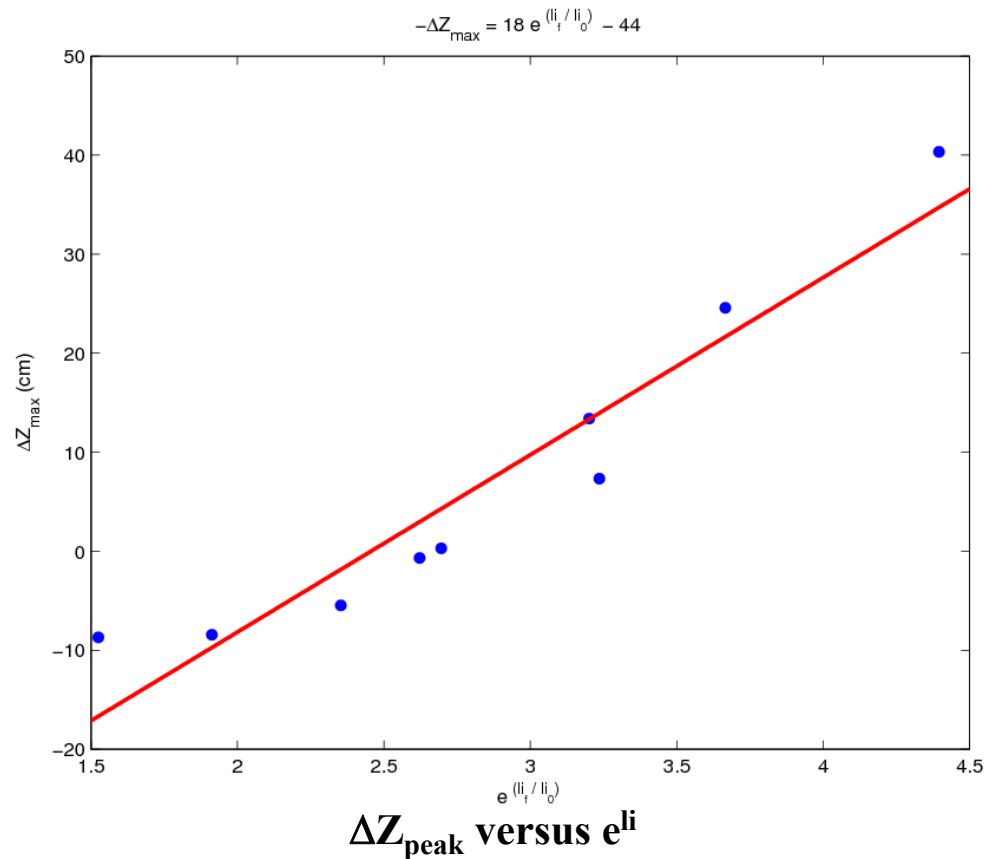

- There is an exponential correlation between ΔZ_{peak} and l_i .
- This is not related to time.
- The reason for this correlation will be studied further.