



National Aeronautics and
Space Administration

Langley Research Center
Hampton, VA 23681-2199

Educational Product	
Educators	Grades 3-5

EG-2001-08-21-LARC

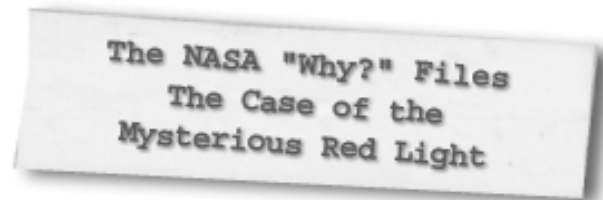

**A Lesson Guide with Activities in
Mathematics, Science, and Technology**



The Case of the Mysterious Red Light lesson guide is available in electronic format through NASA Spacelink - one of NASA's electronic resources specifically developed for the educational community. This publication and other educational products may be accessed at the following address: **<http://spacelink.nasa.gov/products>**

A PDF version of the lesson guide for NASA "Why?" Files can be found at the NASA "Why?" Files web site: **<http://whyfiles.larc.nasa.gov>**

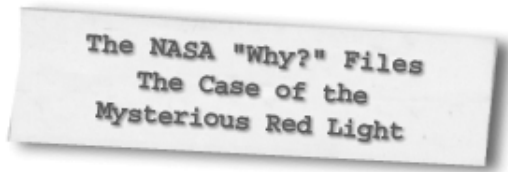

A Lesson Guide with Activities in Mathematics, Science, and Technology

Program Overview5
 National Geography Standards5
 National Science Standards6
 National Mathematics Standards.....8
 National Educational Technology Standards9

Segment 1

Overview11
 Objectives12
 Vocabulary12
 Video Component.....12
 Careers.....13
 Resources14
 Activities and Worksheets14

Segment 2

Overview23
 Objectives24
 Vocabulary24
 Video Component.....24
 Careers.....25
 Resources26
 Activities and Worksheets27

Segment 3

Overview37
 Objectives38
 Vocabulary38
 Video Component.....39
 Careers.....39
 Resources40
 Activities and Worksheets41

Segment 4

Overview57
 Objectives58
 Vocabulary58
 Video Component.....58
 Careers.....59
 Resources60
 Activities and Worksheets61

For additional information about the NASA "Why?" Files, contact Shannon Ricles at (757) 864-5044 or e-mail s.s.ricles@larc.nasa.gov.

Production of the NASA "Why?" Files is made possible by the generous support provided by AIAA Foundation; Busch Gardens, Williamsburg; Hampton City Public Schools; and the NASA Langley Research Center's Learning Technology Project and Aerospace Vehicle Systems Technology Program Office.

Writers and Teacher Advisors: Shannon Ricles, Charlie Thompson, Susan McBurney, Linda Hawkins

Editors: Bill Williams, Susan Hurd



Registered users of the NASA "Why?" Files may request an American Institute of Aeronautics and Astronautics' (AIAA) classroom mentor. For more information or to request a mentor, e-mail nasawhyfiles@aiaa.org.



Program Overview

Each day, for no apparent reason, the morning and evening sky blazes with a brilliant deep red color. In *The Case of the Mysterious Red Light*, the tree house detectives are determined to solve this mystery, but are puzzled as to what phenomena could be causing the bright red sunrises and sunsets.

As the tree house detectives set out to solve this case, they decide to learn more about light. They visit the Boston Science Museum where they learn what light is and how it travels. NASA researchers and other community experts help the tree house

detectives understand the properties of light, including frequency, amplitude, reflection, refraction, and much more.

The tree house detectives get a little help from the famous magician, Franz Harary, who makes a NASA plane disappear before their very eyes. Once the detectives understand that "seeing is not always believing," they are hot on the trail of the possible cause for the brilliant sunrises and sunsets. As they "dust off" their thinking caps, they realize that this case may "erupt" before their very eyes.

National Geography Standards (grades 3-5)

Standard	Segment			
	1	2	3	4
The geographically informed person knows and understands				
The World in Spatial Terms				
How to use maps and other graphic representations, tools, and technologies to acquire, process, and report information from a spatial perspective			x	x
Places and Regions				
The physical and human characteristics of places		x		
Physical Systems				
The physical processes that shape the patterns of the Earth's surface			x	
Environment and Society				
How physical systems affect human systems			x	
Uses of Geography				
How to apply geography to interpret the past			x	



National Science Standards (Grades K – 4)

Standard	Segment			
	1	2	3	4
Unifying Concepts and Processes				
Systems, orders, and organization	X	X	X	X
Evidence, models, and explanations	X	X	X	X
Change, constancy, and measurement	X	X	X	X
Evolution and equilibrium			X	
Form and function			X	
Science and Inquiry (Content Standard A)				
Abilities necessary to do scientific inquiry	X	X	X	X
Understandings about scientific inquiry	X	X	X	X
Physical Science (Content Standard B)				
Properties of objects and materials	X	X	X	X
Position and motion of objects			X	
Light, heat, electricity, and magnetism	X	X	X	X
Earth and Space Science (Content Standard D)				
Properties of earth materials			X	X
Objects in the sky	X		X	X
Changes in earth and sky	X	X	X	X
Science and Technology (Content Standard E)				
Abilities of technological design	X	X	X	X
Understanding about science and technology	X	X	X	X
Science in Personal and Social Perspective (Content Standard F)				
Personal health		X		
Changes in environment	X	X	X	X
History and Nature of Science (Content Standard G)				
Science as a human endeavor	X	X	X	X



National Science Standards (Grades 5 - 8)

Standard	Segment			
	1	2	3	4
Unifying Concepts and Processes				
Systems, order, and organization	X	X	X	X
Evidence, models, and explanations	X	X	X	X
Change, constancy, and measurement	X	X	X	X
Evolution and equilibrium			X	
Form and function			X	
Science as Inquiry (Content Standard A)				
Abilities necessary to do scientific inquiry	X	X	X	X
Understanding about scientific inquiry	X	X	X	X
Physical Science (Content Standard B)				
Motion and forces	X	X	X	X
Transfer of energy	X	X	X	X
Earth and Space Science (Content Standard D)				
Structure of the earth system			X	X
Earth's history			X	
Earth in the solar system			X	X
Science and Technology (Content Standard E)				
Abilities of technological design	X	X	X	X
Understanding about science and technology	X	X	X	X
Science in Personal and Social Perspectives (Content Standard F)				
Personal health		X		
Science and technology in society	X	X	X	X
History and Nature of Science (Content Standard G)				
Science as a human endeavor	X	X	X	X
Nature of science	X	X	X	X



National Mathematics Standards (Grades 3 - 5)

Standard	Segment			
	1	2	3	4
Number and Operations				
Understand meanings of operations and how they relate to one another.			X	X
Compute fluently and make reasonable estimates.			X	X
Algebra				
Understand patterns, relations, and functions.				X
Use mathematical models to represent and understand quantitative relationships.			X	X
Analyze change in various contexts.				X
Measurement				
Understand measurable attributes of objects and the units, systems, and processes of measurement.	X	X	X	X
Apply appropriate techniques, tools, and formulas to determine measurements.	X	X	X	X
Data Analysis and Probability				
Formulate questions that can be addressed with data and collect, organize, and display relevant data to answer them.	X	X	X	X
Select and use appropriate statistical methods to analyze data.				X
Develop and evaluate inferences and predictions that are based on data.				X
Understand and apply basic concepts of probability.	X	X	X	X
Problem Solving				
Build new mathematical knowledge through problem solving.	X	X	X	X
Solve problems that arise in mathematics and in other contexts.	X	X	X	X
Apply and adapt a variety of appropriate strategies to solve problems.	X	X	X	X
Monitor and reflect on the process of mathematical problem solving.	X	X	X	X
Communication				
Organize and consolidate their mathematical thinking through communication.			X	X
Communicate their mathematical thinking coherently and clearly to peers, teachers, and others.			X	X
Analyze and evaluate the mathematical thinking and strategies of others.			X	X
Connections				
Recognize and use connections among mathematical ideas.			X	X
Recognize and apply mathematics in contexts outside of mathematics.				X
Representation				
Create and use representations to organize, record, and communicate mathematical ideas.			X	X
Select, apply, and translate among mathematical representations to solve problems.				X



National Technology Standards (ITEA Standards for Technology Literacy, Grades 3 – 5)

Standard	Segment			
	1	2	3	4
Nature of Technology				
Standard 1: Students will develop an understanding of the characteristics and scope of technology.	X	X	X	X
Standard 2: Students will develop an understanding of the core concepts of technology.	X	X	X	X
Standard 3: Students will develop an understanding of the relationships among technologies and the connections between technology and other fields of study.	X	X	X	X
Technology and Society				
Standard 5: Students will develop an understanding of the effects of technology on the environment.			X	X
Design				
Standard 10: Students will develop an understanding of the role of troubleshooting, research and development, invention and innovation, and experimentation in problem solving.	X	X	X	X
Abilities for a Technological World				
Standard 11: Students will develop the abilities to apply the design process.	X	X	X	X
Standard 12: Students will develop abilities to use and maintain technological products and systems.	X	X	X	X
Standard 13: Students will develop abilities to assess the impact of products and systems.	X	X	X	X
The Designed World				
Standard 17: Students will develop an understanding of and be able to select and use information and communication technologies.	X	X	X	X



National Technology Standards (ISTE National Educational Technology Standards, Grades 3 - 5)

Standard	Segment			
	1	2	3	4
Basic Operations and Concepts				
Use Keyboards and other common input and output devices efficiently and effectively.	X	X	X	X
Discuss common uses of technology in daily life and the advantages and disadvantages those uses provide.	X	X	X	X
Technology Productivity Tools				
Use technology tools for individual and collaborative writing, communication, and publishing activities to create knowledge products for audiences inside and outside the classroom.	X	X	X	X
Technology Communication Tools				
Use technology tools for individual and collaborative writing, communication, and publishing activities to create knowledge products for audiences inside and outside the classroom.	X	X	X	X
Use telecommunication efficiently and effectively to access remote information, communicate with others in support of direct and independent learning, and pursue personal interests.	X	X	X	X
Use telecommunication and online resources to participate in collaborative problem-solving activities for the purpose of developing solutions or products for audiences inside and outside the classroom.	X	X	X	X
Technology Research Tools				
Use telecommunication and online resources to participate in collaborative problem-solving activities for the purpose of developing solutions or products for audiences inside and outside the classroom.	X	X	X	X
Use technology resources for problem solving, self-directed learning, and extended learning activities.	X	X	X	X
Determine when technology is useful and select the appropriate tools and technology resources to address a variety of tasks and problems.	X	X	X	X
Technology Problem-Solving and Decision-Making Tools				
Use technology resources for problem solving, self-directed learning, and extended learning activities.	X	X	X	X
Determine when technology is useful and select the appropriate tools and technology resources to address a variety of tasks and problems.	X	X	X	X



The NASA "Why?" Files
The Case of the
Mysterious Red Light

Segment 1

Realizing that not even magic can make the brilliant red sunrises and sunsets disappear, the tree house detectives begin their investigation by visiting the Boston Museum of Science. There they learn the difference between natural and artificial light, what light is made of, and how light travels.

The tree house detectives feel a bit confused and decide that their next stop needs to be NASA Langley Research Center in Hampton, Virginia. There they speak with Clayton Turner aboard NASA's 757 research plane. Mr. Turner explains what a spectrometer is and clarifies how light can travel both in a straight line and in waves. He further demonstrates wavelength and frequency while explaining the parts of a wave.

The tree house detectives are excited as they formulate a hypothesis. They are sure that they are on the right "frequency" to solve this mystery

Objectives

The student will

- understand the difference between natural and artificial light.
- learn that light is composed of photons.
- learn that light travels in a straight line.
- learn that light travels in waves.
- learn the parts of a wave.
- understand wavelength and frequency.

Vocabulary

amplitude - in a wave, one half the distance from the bottom of the trough to the top of the crest

artificial light - man-made light produced from artificial sources such as electricity

atom - the smallest part of an element

crest - high point of a wave

frequency - number of complete waves that pass a fixed point in a given unit of time

light - a form of energy called radiant energy that travels freely through space

natural light - light that comes from natural sources such as the Sun, lightning, and fire

photons - a tiny packet or bundle of energy belonging to a particular wavelength that is released when an electron loses its extra energy. Light is a stream of photons.

ray - a straight line that represents the motion of light in one direction

spectrometer - an instrument that separates light into its respective frequencies or waves and has a scale for measuring the frequency or wavelength

trough - lowest point of a wave

wave - disturbance that transfers energy through matter or space

wavelength - distance between any two corresponding points on successive waves, usually crest-to-crest or trough-to-trough

Video Component

Implementation Strategy

The NASA "Why?" Files is designed to enhance and enrich the existing curriculum. Two to three days of class time is suggested for each segment to fully use video, resources, activities, and web site.

Before Viewing

1. Prior to viewing Segment 1 of *The Case of the Mysterious Red Light*, read the program overview (p. 5) to the students. List and discuss questions and preconceptions that students may have about light.
2. Record a list of issues and questions that the

students want answered in the program. Determine why it is important to define the problem before beginning. From this list, guide students to create a class or team list of three issues and four questions that will help them to better understand the problem. The following tools are available on the web site to assist in the process.

Problem Board - printable form to create student or class K-W-L chart

PBL Questions - questions for students to use while conducting research

Problem Log - printable log for students with the stages of the problem-solving process



2001 – 2002 NASA “Why?” Files Programs

The Scientific Method - chart that describes the scientific method process

3. **Focus Questions** - questions at the beginning of each segment help students focus on a reason for viewing the videotape and can be printed from the web site so that students can write them in their science journals. Encourage students to take notes during the show to answer the questions.

View Segment 1 of the Video

For optimal educational benefit, view *The Case of the Mysterious Red Light* in 15-minute segments and not in its entirety.

After Viewing

1. Have students reflect on the “What’s Up?” questions asked at the end of each segment.
2. Have students work in groups or as a class either to develop a hypothesis or to determine if the tree house detectives’ hypothesis is correct. Guide students to determine if their choices are possible solutions, facts, or pure speculations. Extend this discussion by having them rank their choices. Investigate the top two choices.

Validation Station - printable form to help students validate their hypothesis

3. Choose activities from the educator’s guide and web site to reinforce concepts discussed in the segment. The variety of activities is designed to enrich and enhance your curriculum. They also help students “solve” the problem along with the tree house detectives. Ask students, “Why is it important for the tree house detectives to know these concepts?” For example: Why would they need to know the difference between natural and artificial light? After completing the activity, “Natural or Artificial” (p. 15), the students should be able to understand that the bright red sky is not coming from an artificial source and therefore rule out possibilities such as bright streetlights.
4. Have the students work individually, in pairs, or in small groups on the problem-based learning activity on the NASA “Why?” Files web site.

To begin the PBL activity, read the scenario to the students.

Read and discuss the various roles involved in the investigation. Have each student choose his/her role.

Print the criteria for the investigation and distribute.

Have students use the Research Rack located on the web site and the online tools that are available.

5. Having students reflect in their journals what they have learned from this segment and from their own experimentation and research is one way to assess their understanding. In the beginning, students may have difficulty reflecting. To help students, give them specific questions related to the concepts to reflect upon.
6. The NASA “Why?” Files web site provides checklists and rubrics that may assist teachers in assessment. Other tools found on the web that can be useful in assessing students’ learning are the Problem Log and the Validation Station.

Careers

museum curator
magician
engineer
professor



Resources (additional resources located on web site)

Books

Burnie, David: *Eyewitness: Light*. DK Publishing Inc., 1999, ISBN: 0789448858

Cobb, Vicki; Josh Cobb; Theo Cobb (illustrator); and Joshua Cobb. *Light Action! Amazing Experiments with Optics*. Harper Collins Children Books, 1993, ISBN: 0060214376

Web Sites

Physics with David Harris

A great resource for your physics questions. Includes an online dictionary, articles covering various subjects, and links to over 700 sites.
<http://physics.about.com/mbody.htm>

Boston Museum of Science

Check out the Boston Museum of Science. Visit the great online exhibits and educators' resources.
<http://www.mos.org/home.html>

How Stuff Works: Light

This site looks at light from many different angles. It helps people understand "How Light Works!"
<http://www.howstuffworks.com/light.htm>

The Center for Science Education at the Space Sciences Lab: Light Tour

This site addresses the behavior of light, measuring a light wavelength and properties of a wave.
<http://cse.ssl.berkeley.edu/light/measure.html>

ThinkQuest: Discovering Light

This web site provides background on the physics of light, light in nature, and light in technology, a great background resource that covers a wide range of content areas within the topic of light.
<http://library.thinkquest.org/27356/index.htm>

The Sun

This site has a collection of facts and images of the Sun.
<http://seds.lpl.arizona.edu/nineplanets/nineplanets/sol.html>

NASA Sun-Earth Day

Visit this site to learn about common misconceptions held about the Sun-Earth relationship.
http://sunearth.gsfc.nasa.gov/SECEF_SunEarthDay/Ten.htm

Activities and Worksheets

In the Guide	<p>Natural or Artificial Learn the difference between natural and artificial light.15</p> <p>Photons Learn how photons travel from the Sun to the Earth.16</p> <p>Traveling the Straight and Narrow Explore how light travels in a straight line.17</p> <p>Roping the Wave Demonstrate light traveling in waves.18</p> <p>Wave Upon Wave Understand wave frequency.19</p> <p>Roll Out the Frequency Learn how frequency and wavelength are related.20</p>
On the Web	<p>The Incredible Edible Wave Learn the parts of the wave and then enjoy it!</p>



Natural or Artificial

Almost all the natural light the Earth receives comes from the Sun. The Sun is a star that creates its own light. People control some sources of light called artificial light. Look at the pictures below and determine if they are sources of natural or artificial light.

Lightning Bug

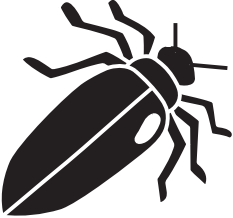

1. _____

TV



2. _____

Stars



3. _____

Lamp

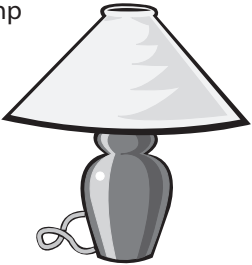

4. _____

Flashlight

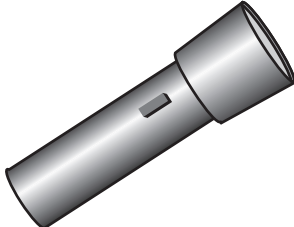

5. _____

Campfire

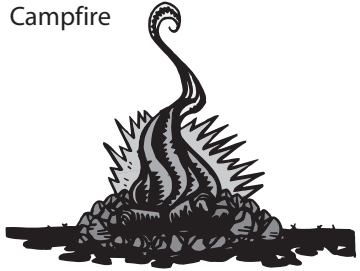

6. _____

Sun

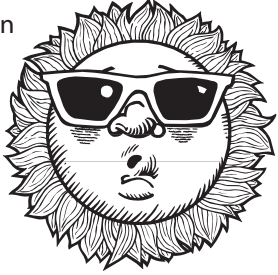

7. _____

Volcano



8. _____

Lightning

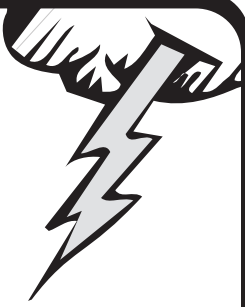

9. _____

List two more sources of natural light. _____

Explain the difference between natural light and artificial light. _____

(optional) To learn more about the types of light, research these terms and give an example of each:

Direct light: incandescent light

Indirect light: fluorescent light

Reflected light: neon light

Photons

Purpose

To simulate photons in light.

Procedure

1. Prior to the simulation, the teacher should outline an area on the ground approximately 3m x 3m to represent the Earth.
2. To represent the Sun, outline another area as a large circle approximately 5-8 m in diameter and 15-20 m from the Earth.
3. Discuss with the class the definition of a simulation.
4. Place students in the center of the Sun.
5. Have one student stand on the edge of the circle facing the Earth and grasp one end of the rope. He/she will be the first photon.
6. Stretch the rope in a straight path toward the Earth.
7. Explain that the students in the Sun represent photons emerging from the Sun.
8. To begin the simulation, choose one of the photons to leave the Sun and tag the first photon at the edge of the circle.
9. Never letting go of the rope, the "tagged" photon will then move up the rope to the next mark on the rope.
10. Meanwhile, other photons should leave the Sun in an orderly fashion, tagging the last photon on the edge of the circle and repeating the above to create a "chain reaction" that simulates a flow of photons (light) from the Sun.
11. Continue until all photons have left the Sun.
12. Discuss the simulation with the students.

Materials

large open area such as a playground or field
chalk or duct tape to outline areas
15-20 m of thick rope knotted on each end and sectioned off in 1 m increments (use marker or tape)

Extension

After discussing reflection, refraction, and scattering, use this simulation to enhance student understanding of what happens to light as it enters the atmosphere and strikes the Earth. Some of the photons could scatter before reaching the Earth, some could strike "clouds" and reflect, or some could strike the surface of the Earth and reflect, absorb, or refract.

Conclusion

1. How do the photons represent a beam of light? _____

2. What would happen if the photons stopped coming? _____

3. Draw a diagram that represents the simulation.



Traveling the Straight and Narrow

Purpose To learn that light travels in a straight line

- Procedure**
1. Lay the white paper on a flat surface.
 2. Determine the lengthwise center of the paper and use the ruler to draw a straight line from one end to the other.
 3. From one end of the paper, mark points on the line at 6 cm, 12 cm, 18 cm, and 24 cm.
 4. Place a small amount of clay at each point.
 5. On one of the index cards, mark point 3.5 cm from the bottom of the card and 2 cm from the left of the card. See diagram 1.
 6. Lay this card on top of the other two cards and make sure they are correctly aligned.
 7. Use the hole puncher to punch a hole over the mark through all three cards.
 8. Place a card in the first three mounds of clay and line up the holes. See diagram 2. Place the card without the hole in the last mound of clay.
 9. Darken the room and shine the flashlight directly through the hole on the first card.
 10. Observe the path of light and the size of the beam on each card. Record your observations in your journal.
 11. Move the light at a 45° angle and shine it through the hole of the first card.
 12. Observe the path of light and record your observations.

Materials

- 30 cm of white paper (shelf paper works great)
- 4 index cards
- hole puncher
- metric ruler
- pencil
- small amount of clay
- small flashlight or penlight
- science journal

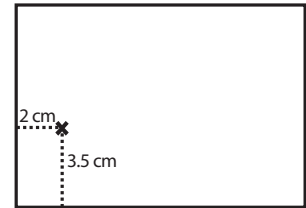

Diagram 1

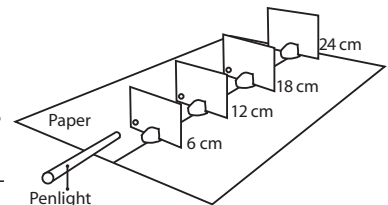

Diagram 2

Conclusion 1. How did the size of the light beam change on each card?

2. What happened when you changed the angle of the light?

3. Does light travel in a straight line? Explain how you know. _____

4. Why would the tree house detectives need to know that light travels in a straight line? _____

Extension

Make 4 additional index cards with larger holes. Place them in a straight line and darken the room. Shine the flashlight through the holes and observe. To make this experiment really visible, clap two chalk erasers or spray water mist in the air. Experiment by repositioning the various cards.



Roping the Wave

Purpose

To demonstrate light traveling in waves

Procedure

1. This activity can be performed as a teacher demonstration or by students in small groups.
2. Have one student hold one end of the rope and a second student hold the other end.
3. Have one of the students slowly move the rope up and down while the other student holds his/her end still.
4. Observe the waves.
5. Move the rope more quickly and observe.
6. Stretch a slinky on the floor between two students about 6-10 m apart.
7. Repeat Steps 2-4 with the slinky.
8. In your science journal, explain the differences you observed in the waves.

Materials

4-5 m of rope
slinky
science journal

Conclusion

1. How did the length of the wave change when you changed the amount of force you applied to the rope and slinky? _____
2. What does this tell you about the energy source of a wave? _____

3. Are long waves likely to be produced by a low-energy source or a high-energy source? Explain. _____

4. What about short waves? Explain. _____

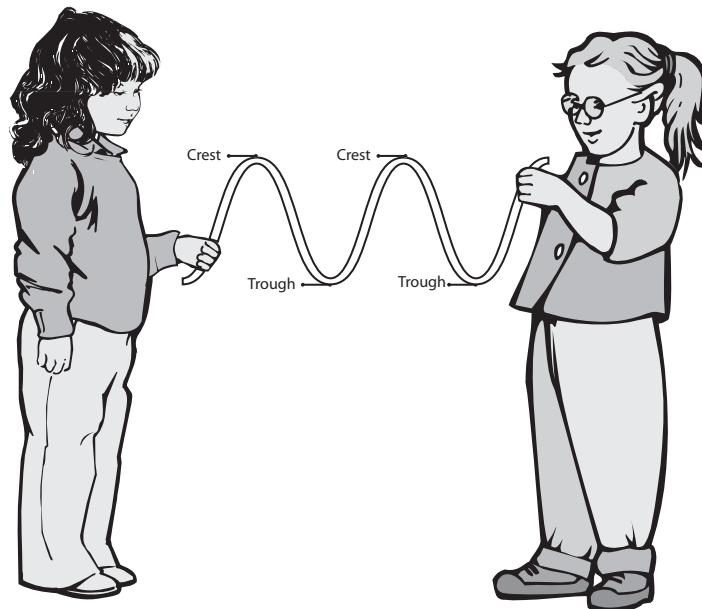

Wave Upon Wave

Purpose

To understand wave frequency

Procedure

1. Soften the clay and roll it into a ball. Place the clay on the bottom of the pan near the end.
2. Insert the craft stick into the clay ball perpendicular to the bottom of the pan. See diagram 1.
3. Fill the pan two-thirds full of water.
4. Using the side of your hand, slowly strike the water's surface three times at the end opposite the stick.
5. Observe the waves that were created.
6. Repeat striking the water slowly three times, but this time count the number of waves that pass the stick in five seconds. Count the waves by observing either the crests (tops) or the troughs (bottoms) of the waves.
7. Record results in science journal.
8. Repeat striking the water three times, but more quickly. Count the number of waves that pass in five seconds. Record.
9. Experiment with striking the water at various speeds.
10. Experiment with timing the waves for 10 seconds and 20 seconds.

Materials

rectangular-shaped pan
clay
craft stick
water
stopwatch or clock with second hand
science journal

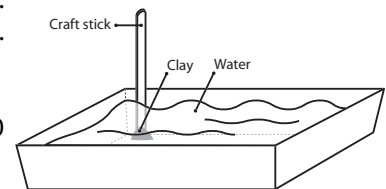

Diagram 1

Conclusion

1. Which action produced more waves? Why? _____

2. What happened when you increased the number of seconds you counted the waves? Explain why this happened. _____

3. From your observation, write your own definition of frequency. _____

Extension

The teacher may conduct this experiment by using an overhead projector and a clear rectangular glass dish. Place the glass dish on the overhead projector, insert clay and craft stick, and add water. Make sure that no water has spilled onto the projector. Turn on the projector and have students view the waves on the projection screen. Because this experiment involves water and electrical equipment, it should be done by an ADULT only.

Roll Out the Frequency

Purpose

To understand frequency and wavelength

Procedure

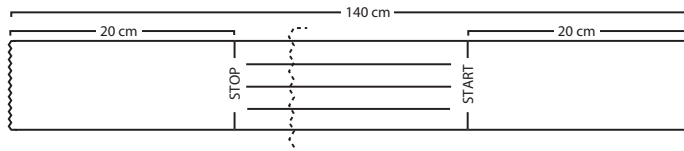

Diagram 1



Diagram 2

Materials (per group)

140 cm adding machine tape (1.4 m)
metric ruler
pencil
colored pencils (red, green, and violet)
manila folder
scissors
tape
pencil or dowel
stopwatch or clock with second hand

1. Measure 20 cm from one end of the adding machine tape and draw a vertical line. Label this end "Start."
2. Repeat with the other end of the adding machine tape. Label this end "Stop."
3. Use a metric ruler to draw three evenly spaced horizontal lines from start to stop in the center of the adding machine tape. See diagram 1.
4. Color the top line red, the middle line green, and the bottom line violet.
5. Use a metric ruler and red pencil to measure and mark the red line every 14 cm, making dark wavelength marks that are easy to see. See diagram 2.
6. Repeat, dividing the green line with the green pencil every 10 cm and the violet line with the violet pencil every 8 cm.
7. From the left bottom edge of the manila folder, measure and mark 12.5 cm. Repeat from the right bottom edge of the folder.
8. Using the marks as guides, measure 10 cm from the bottom of the manila folder upward along the marks. Mark the spot and then draw a line from the bottom to that mark.
9. Connect the two lines at the top to form a rectangle. See diagram 3.
10. Use scissors to cut out the rectangle. Cut through both sides of folder.
11. Roll adding machine tape into coil with the "start" end visible. See diagram 4.
12. Place the "start" end of the adding machine tape inside the manila folder so that "start" shows through the cutout window with the excess sticking out the right side of the folder. Close folder so that the roll of adding machine tape is to the left of the folder. See diagram 5.
13. With one person holding the folder, another person pulls the "Start" end of the adding machine tape slowly. A third person uses a stopwatch to time the activity as a fourth person counts the number of red wavelength marks that pass through the rectangular opening in 10 seconds.
14. Timekeeper will announce when to begin and end the activity.
15. After the timekeeper has ended the activity, record in science journal the number of red wavelength marks that passed.
16. Making sure that the tape is pulled at about the same speed for every trial, repeat two more times. Find the average number of wavelength marks that were passed for all three trials.
17. Repeat steps 11-16 for the green and violet lines.

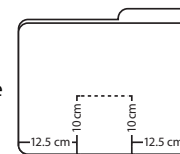

Diagram 3

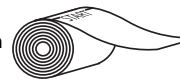

Diagram 4

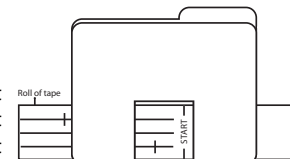

Diagram 5

Conclusion

1. Compare the wavelengths and frequencies of the three waves. Describe any patterns or relationships that were noted. _____
2. Which color had the shortest wavelength? Longest? _____
3. Which color has the highest frequency? Lowest frequency? _____
4. Why was it important to take an average? _____
5. Why do the tree house detectives think that there are low frequency waves causing the red skies? _____
6. In your science journal, summarize this activity and tell how it relates to *The Case of the Mysterious Red Light*.



Answer Key

Natural or Artificial

1. street light and illuminated clock
2. burning match and flaming coals
3. Natural light is created from natural sources such as the Sun. Artificial light is created by man-made sources such as lamps.

Photons

1. The photons travel in a straight line just as a beam of light travels. Light is made up of a stream of photons.
2. If there were no photons, there would not be any light.
3. Drawings will vary.

Traveling the Straight and Narrow

1. The light around the hole in each card gets smaller and dimmer the farther it is from the light source.
2. When the light is aimed at an angle, it doesn't strike the second, third, or last card.
3. Only when the light is aligned with the straight line through the index card holes can light reach the last cards. This demonstration shows that light travels in a straight line.
4. Answers will vary.

Roping the Wave

1. When force was increased, the length of the wave became shorter.
2. An energy source that produces high energy produces very short wavelengths, and an energy source that produces low energy produces very long wavelengths.
3. Long waves are produced by low-energy sources. The less energy used to create a wave, the longer the wavelength.
4. Short waves are produced by high-energy sources. The more energy used to create a wave, the shorter the wavelength.

The Incredible Edible Wave

1. In a wave, the crests will always be the same height because they are all produced by the same energy source.

Wave Upon Wave

1. Striking the water more rapidly creates more waves. Each strike to the water produces energy that creates waves; therefore, the more strikes to the surface of the water, the more waves.
2. When timing and the number of seconds were increased, the waves slowed down and there were fewer waves per second than in the beginning.
3. Frequency is the number of waves that pass a given point in a certain amount of time.

Roll Out the Frequency

1. The wavelengths graduated from longest to shortest. The shorter the wavelength, the more wavelength marks in the ten second time period.
2. violet, red
3. violet, red
4. It was important to take an average because it was difficult to maintain the same speed in each trial.
5. The tree house detectives think low-frequency waves are causing the sky to be red because low frequency waves are red in the visible spectrum.
6. Answers will vary.

The NASA "Why?" Files
The Case of the
Mysterious Red Light

Segment 2

As the tree house detectives continue their search for clues to solve the mystery of the brilliant red sunrises and sunsets, they go to Jefferson Lab in Newport News, Virginia. At this nuclear physics research facility, Dr. Michelle Shinn demonstrates how light reflects and refracts as it hits various surfaces and how mirrors can bounce light from one place to another.

Franz Harary, the famous illusionist, uses a little magic of his own to transport two of the tree house detectives to NASA Dryden Research Center in Edwards, California where he makes a NASA plane disappear. Once they are returned to Dr. D's lab, the tree house detectives learn the difference between transparent, translucent, and opaque. Understanding what the three words mean leads the tree house detectives to question why the sky appears blue during the day.

To answer that question, the tree house detectives visit Dr. Peter Pilewskie at NASA AMES Research Center at Moffett Field, California to learn about scattering. This new knowledge propels the detectives to question what could be causing the scattering. They make a final stop at NASA Langley Research Center in Hampton, Virginia to talk with Mark Vaughan, a LIDAR researcher who enlightens them on the main causes of pollution. The tree house detectives are surprised to learn that "Mother Nature" can really kick up her heels and raise some dust!

Objectives

The students will

- understand the difference between reflection and refraction.
- learn about plane, concave, and convex mirrors.
- learn how illusions are created.
- be able to differentiate between transparent, translucent, and opaque.
- learn that the Earth's atmosphere is composed of gases and aerosols.
- understand the effect aerosols have on scattering light.
- learn how aerosols occur in the atmosphere.
- learn how scientists measure aerosols in the atmosphere.

Vocabulary

aerosols - tiny solid or liquid particles suspended in the atmosphere

atmosphere - thin blanket of air surrounding the Earth and containing gases (oxygen, nitrogen, and trace gases), solids, and liquids

concave mirror - a mirror that is curved inward and makes images appear larger and closer

convex mirror - a mirror that is curved outward and makes images appear smaller and farther away

fiber optics - very thin glass created to hold pulses of laser light that can carry 65,000 times more information than conventional copper wire

laser - an acronym for light amplification by stimulated emissions of radiation. Light waves in a laser beam are all identical in wavelength and frequency and the light is truly of one color (monochromatic).

LIDAR - Light Detection and Ranging Laser. Active remote sensing that uses pulses of laser light to detect particles or gases in the atmosphere.

mirror - a flat, smooth surface made by putting a thin layer of silver or aluminum onto a sheet of high-quality glass

opaque - a material that blocks all light rays, preventing a person from seeing through it at all

plane mirror - a mirror with a flat surface in which the image is the same size as the reflected object

reflection - a change in direction when light strikes and rebounds from a surface or the boundary between two media

refraction - the bending of light as it changes speed when it passes from one material to another

scattering - bouncing of light in another direction when it hits a molecule in the atmosphere

translucent - a material that mixes light rays and allows a person to see through it, but not clearly

transparent - a material that does not mix light rays and allows a person to see through it clearly

Video Component

Implementation Strategy

The NASA "Why?" Files are designed to enhance and enrich the existing curriculum. Two to three days of class time is suggested for each segment to fully use video, resources, activities, and web site.

Before Viewing

1. Prior to viewing Segment 2 of *The Case of the*

Mysterious Red Light, discuss the previous segment to review the problem and what the tree house detectives have learned thus far. Sort information by using the "Need to Know Board."

2. Review the list of questions and issues that the students created prior to viewing Segment 1 and determine which, if any, were answered in the video or in the student's own research.
3. Revise and correct any misconceptions that may



have been dispelled during Segment 1. Use tools located on the web, as previously mentioned in Segment 1.

4. Discuss the two hypotheses that the students generated at the end of Segment 1 and decide if information learned supports their existing hypotheses or if they need to revise them. Choose one of the hypotheses and continue investigating.
5. **Focus Questions** - Print the questions from the web site ahead of time for students to copy into their science journals. Encourage students to take notes during the show to answer the questions.

View Segment 2 of the Video

For optimal educational benefit, view *The Case of the Mysterious Red Light* in 15-minute segments and not in its entirety.

After Viewing

1. Lead students to reflect on the "What's Up?" questions asked at the end of the segment.
2. Have students discuss their hypothesis and determine if they can continue to support it or if a new hypothesis needs to be created. Consider the new hypothesis introduced at the end of the segment by the tree house detectives: If there is pollution in the air, then the sky will be red. Reflect on their choice compared to your students' hypotheses. Ask the students what Jason and Matt meant when they said that their hypothesis was not wrong, but that they needed a "stronger" hypothesis.
3. Choose activities from the educator guide and web site to reinforce the concepts discussed in the segment. Pinpoint areas in your curriculum that may need to be reinforced and use activities to aid students' understanding in those areas. Use the activities to "help" the tree house detectives solve the mystery. Help students see the correlation between the information learned and the clues used to solve the mystery.

Careers

laser physicist
 illusionist
 magician
 research scientist
 LIDAR researcher
 atmospheric scientist

4. If time did not permit you to begin the web activity at the conclusion of Segment 1, refer to number 4 on page 13 and begin the problem-based learning activity on the NASA "Why?" Files web site. If the web activity was begun, monitor students as they research within their selected roles and review criteria as needed. Encourage the use of the following portions of the online problem-based learning activity:

Research Rack - books, internet sites, and research tools

Dr. D's Lab - online simulation "Additive and Subtractive Colors" and hands-on activities for the home or class.

Media Zone - interviews with experts from this segment

5. Have students reflect in their journals what they have learned from this segment and their own experimentation and research. If needed, give students specific questions to reflect upon or select an activity or exercise from the "Problem Log."
6. Continue to assess the students' learning as appropriate by using their journal writings, checklists, rubrics, and other tools that can be found at the NASA "Why?" Files web site in the "Tools" section of the educators' area.



Resources

Books

Hiner, Mark: *The Red and Blue Illusion Book: How to Create 3-D Drawings and Other Optical Tricks*. Tarquin Publications, 1997, ISBN: 1899618058

Kay, Ketih: *The Little Giant Book of Optical Illusions*. Sterling Publishing Company, Inc., 1997, ISBN: 0806961740

Lynch, David K. and Livingston, William: *Color and Light in Nature*. Cambridge University Press, 2001, ISBN: 0521772842

Cosgrove, Brian: *Eyewitness: Weather*. DK Publishing Inc., 2000, ISBN: 0789457822

Mogil, Michael H. and Discovery Channel: *Weather: An Explore Your World Handbook*. Discovery Books, 1999, ISBN: 1563318024

Web Sites

Atmospheric Sciences-NASA Langley Research Center

Homepage with links to information on LIDAR, atmospheric sciences, educational outreach activities, and video clips on aerosols.
<http://asd-www.larc.nasa.gov/ASDhomepage.html>

NASA Langley Research Center's Aerosol Trading Cards

Learn what aerosols are, how they are formed, and how NASA uses instruments to collect data on atmospheric aerosols around the globe!
<http://eosweb.larc.nasa.gov/EDDOCS/Aerosols/Intro2.html>

TERRA- What are Aerosols?

This site describes what aerosols are through text and images and explains how and why NASA studies the atmosphere.
<http://terra.nasa.gov/FactSheets/Aerosols/>

NASA Ames Research Center

Home of Airborne Remote Sensing. Locate information on Earth science and remote sensing.
<http://asapdata.arc.nasa.gov/>

NASA Apollo Image Gallery

Archives of Apollo images from each of the Apollo missions.
http://www.apolloarchive.com/apollo_gallery.html

Jefferson Lab-Thomas Jefferson National Accelerator Facility

Research facility built to probe the nucleus of an atom by using continuous high-energy electron beams. The Jefferson Lab web site also has excellent educational resources for teachers and students that focus on atoms, matter, elements, and physics. It also contains a great online glossary, a virtual tour of the facility, and a listing of internships and workshops for students and teachers.
<http://www.jlab.org/>

See the Light

This ThinkQuest web site created by kids teaches people about basic principles of light, properties of light, color, and optics.
<http://library.thinkquest.org/13405/index.html>

Encyclopedia of the Atmospheric Environment

This online encyclopedia is a resource for a range of atmospheric issues, including air quality, global warming, and ozone depletion. The online encyclopedia also introduces the atmosphere and branches out to cover topics such as pollution, the water cycle, wind, and weather.
<http://www.doc.mmu.ac.uk/aric/eae/english.html>



Activities and Worksheets

In the Guide	The Zig-Zag Race of Reflectors Fun competition to learn how light reflects using plane mirrors	28
	The Bendable Light Activity using gelatin to learn how light is bent by reflection.	29
	Refraction Action Five different stations for students to learn the meaning of refraction.	30
	Multiple Monies Multiply your money with this optical illusion using reflection.	32
	Transparent, Translucent, and Opaque Activity presenting the difference between transparent, translucent, and opaque.	33
	Blue, Blue, Where are You? Activity about how aerosols scatter light.	34
	Answer Key	35
On the Web	Pouring a Little Light on the Subject Activity featured by the tree house detectives that shows how light can reflect within a stream of water.	
	It's a Bird. It's a Plane. No, it's an Aerosol! Use this activity to measure aerosols in your atmosphere.	



The Zig Zag Race of Reflectors

Purpose

To learn that light reflects

Procedure

1. Place students in groups of five or six.
2. Designate one student to hold the flashlight and the others to hold a mirror about waist high while facing each other in two parallel lines one meter apart.
3. Darken the room and have the student with the flashlight shine the light on the first mirror.
4. The student holding the first mirror will then reflect the light from his/her mirror to the mirror across from him/her. That student will reflect the beam to the next mirror across from him/her and so on, zigzagging the light beam until it reaches the last mirror. Students may need to practice a few times.
5. Once the students have practiced, have a race to see which team can reflect the light to the last mirror the fastest.

Materials (per group)

1 flashlight
4-5 mirrors

Conclusion

1. How is light from the flashlight reflected? _____

2. How did you get the light to reflect to the next mirror? _____

3. Discuss whether anything could reflect into the sky and change its color. _____

4. How is reflection of light being used in research? _____

Extension

Students can try to reflect the light in other patterns or alternate the length between the beams.

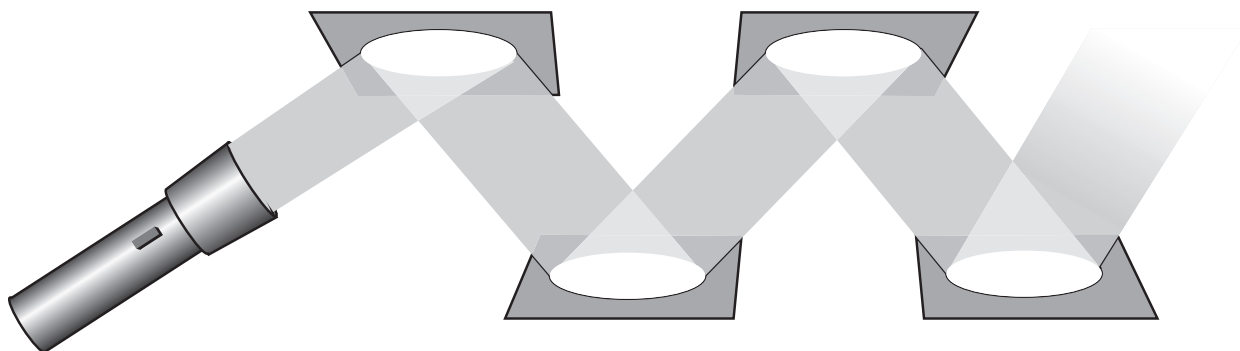

The Bendable Light

Purpose

To understand total internal reflection of light in fiber optics

Procedure

Teacher Prep

1. Line the bottom of the pan with aluminum foil so that the foil extends over the ends of the pan.
2. Spray the foil and sides of the pan with vegetable oil.
3. Mix 4 packages of gelatin in a large bowl with 2 cups of hot water.
4. Stir with spoon until the gelatin is dissolved.
5. Pour gelatin into the pan about 1.5 – 2 cm (1/2 to 3/4 in.) deep.
6. Place the pan of gelatin in the refrigerator and let set for about 3 hours.
7. Take the pan out of the refrigerator and grasp the ends of the aluminum foil to lift the set gelatin out of the pan and place it on the cutting board.
8. With a sharp knife, cut lengthwise strips about 2 cm (3/4 in.) wide.
9. Carefully lift the strips off the board and give each group 1-2 strips.

Student Activity

1. Keeping the gelatin flat and straight, shine the penlight through one end of the gelatin. Observe and record.
2. Continue to shine the light through the gelatin and place an index card at the opposite end of the gelatin strip. Observe and record.
3. Gently make shallow curves with the gelatin strip to form an "S" shape.
4. Repeat steps 1-2.
5. If there is more than one strip of gelatin, connect the strips end-to-end and repeat steps 1-2.
6. Gently make shallow curves with the gelatin strips to form a big "S" shape and repeat steps 1-2.
7. Experiment with the gelatin, making the curves sharper until the light no longer travels through the gelatin.
8. In your science journal, write an explanation of what happened.

Conclusion

1. Explain how the light was able to bend when an "S" shape was made? _____

2. If you connected two strips together, did the light shine through the second strip? Why or why not? _____

3. Why did the light finally stop shining through the gelatin? _____

4. What are some uses of fiber optics? _____

Materials

- 4 packages gelatin desert mix (white grape flavor works the best)
- 2 cups of hot water
- 9 X 13 in. pan
- aluminum foil
- vegetable oil spray
- large bowl
- spoon
- sharp knife
- spatula
- cutting board
- penlight (per group)
- index card (per group)



Refraction Action

Purpose

To understand refraction

Teacher Prep

1. **Station 1:** Place one of the small, clear containers with water on a flat surface. Insert a pencil and a ruler into the water.

Station 2: Place the glass jar with water on a flat surface and put a piece of paper with words printed on it beside the jar.

Station 3: Place a glass microscope slide, eyedropper, small container of water, paper with printed words, and paper towels on a flat surface.

Station 4: Place a coin in a small container of water and put it on a flat surface.

Station 5: Draw a horizontal line 10 cm from the lengthwise edge of the white construction paper. Directly below the line and six inches apart, draw and color two identical objects (stars, fish, or flowers). Place the glass baking pan so it covers only one of the objects. You may want to laminate the paper first to keep it dry.

2. On each index card, write a station number and place prominently at each station.
3. Divide your class into five groups and assign each group a station.
4. Distribute activity sheets and have the students write a definition of refraction.
5. Explain to the students that they will be rotating through five stations. When it is time to rotate to the next station, the students should rotate to the next higher number with station 5 going to station 1.
5. Have the students go to their stations. Allow 3-5 minutes for each station and indicate to the students when it is time to move to the next station.

Materials (5 stations)

3 small, clear containers 3/4 full of water
pencil
ruler
large glass jar 1/2 full of water
3 papers with printed words on them
glass microscope slide
eyedropper
glass baking pan filled with water
white construction paper (9 X 18 in.)
coin
paper towels
activity sheet
index cards



Refraction Action

Light can be reflected and it can also be refracted. Write a definition of refraction:

Refraction is _____

Complete the following activities at each station to learn more about refraction. Record your observations at each station before you go to the next station.

Station 1

Look at the ruler and pencil through the side of the glass.

Observations: _____

Station 2

Hold the printed paper behind the jar and observe the word above the water and below the water.

Observations: _____

Station 3

Hold the microscope slide over the printed paper. Fill the eyedropper with water and drop one or two drops onto the slide. Observe. Dry the slide.

Observations: _____

Station 4

Look at the coin in the cup. Move back from the cup until the coin is invisible.

Observations: _____

Station 5

Look at the paper and its markings. What do you notice about the line and the objects under the pan as compared to those not covered?

Observations: _____

Conclusion

1. Write a definition for refraction: _____

2. What causes light to refract an image? Can you list other times you have seen things refracted? _____

3. How will learning about refraction help the tree house detectives? _____



Multiple Monies

Purpose

To help students understand how optical illusions can be created

Procedure

1. Place the hinged mirrors upright on a flat surface in front of you.
2. Place the dime in the center of the two mirrors.
3. Slowly open and close the mirrors around the dime.
4. Observe and record your observations.

Materials

2 identical mirrors taped together to make a hinge
dime
science journal

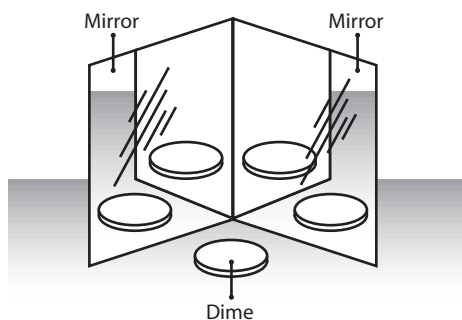

Conclusion

1. What was the least number of dimes that you made appear? _____
2. What was the greatest number of dimes that you made appear? _____
3. How did the dimes multiply? _____

4. Explain how you think magicians might use mirrors to perform tricks. _____



Transparent, Translucent, and Opaque

Purpose

To understand the difference between transparent, translucent, and opaque

Procedure

1. Look at the chart below and for each object predict if it is transparent, translucent, or opaque. Record your prediction.
2. Test each object by shining the flashlight at the object while observing from the other side.
3. Record the results and compare the results to your predictions.

Conclusion

1. Use the back of this sheet to list and make predictions about five other objects in the classroom.

Materials

wax paper
 aluminum foil
 saran wrap
 notebook paper
 construction paper
 paper plate
 clear tape
 tissue
 glass with colored water
 flashlight

1. Tissue
 Predict Result



2. Colored water
 Predict Result



3. Aluminum foil
 Predict Result

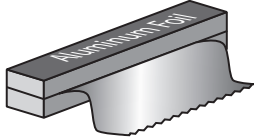

4. Plastic wrap
 Predict Result

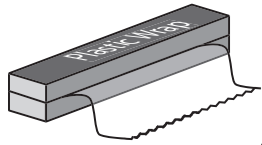

5. Notebook paper
 Predict Result

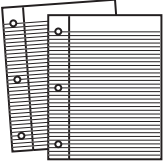

6. Construction paper
 Predict Result

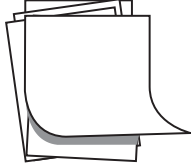

7. Wax paper
 Predict Result

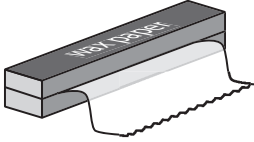

8. Paper plate
 Predict Result

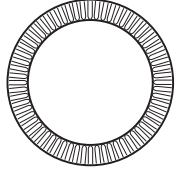

9. Clear tape
 Predict Result



Key

- Transparent—light goes through easily
- Translucent—some light goes through
- Opaque—no light goes through

2. Is a cloudless sky transparent during the day? How does it differ from a cloudless night sky?

3. What type of sky do astronauts see from space? Why? _____



Blue, Blue, Where Are You?

Purpose

To learn how aerosols scatter light

Procedure

1. Fill the glass container 3/4 full with water.
2. Place the container on a flat surface and let the water become still.
3. Once the water is still, turn on the flashlight and shine it through the side of the container. Observe the beam of light from the side and from the end.
4. Hold the index card about 30 cm away from the container and directly opposite the beam of light. See diagram. Observe the light as it projects onto the card.
5. Add a spoonful of milk to the water and stir.
6. Repeat steps 3-5.
7. Continue to add spoonfuls of milk to the container until the light will no longer shine through the water.

Materials

clear glass container
such as a jar or beaker
flashlight
small amount of milk
spoon
plain index card
water

Conclusion

1. What color was the light as you viewed it through the container of clear water? What color was the light on the index card? _____

2. Describe what happened when you added a spoonful of milk. Why? _____

3. Describe what happened as you continued to add milk? Why did this occur? _____

4. How can this experiment explain blue skies during the day and red skies at sunrise and sunset? _____

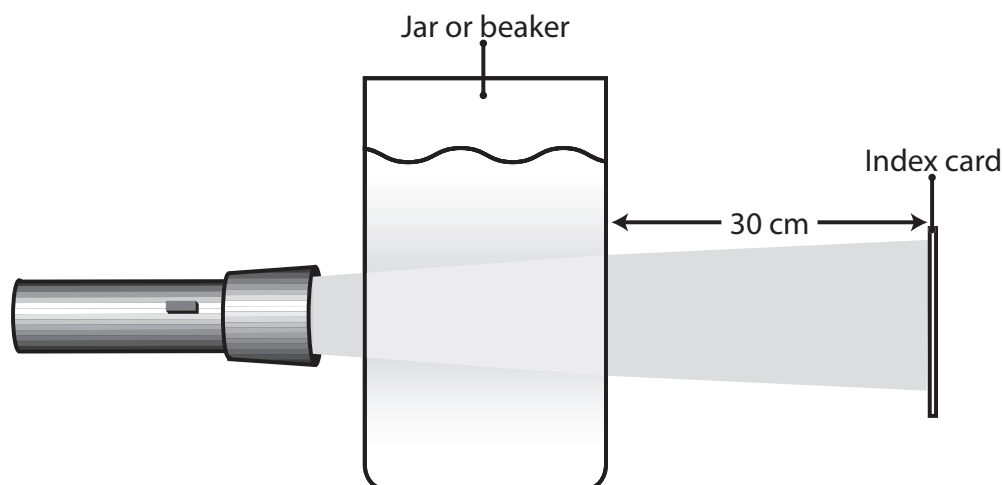

Answer Key

Zig-Zag Race of Reflectors

1. The light is reflected because it hits the smooth, shiny surface of the mirror. The characteristics of the mirror enable light to bounce off and create what is called reflection.
2. To get the light to reflect to the next mirror, the mirror must be angled and directed toward the next mirror.
3. Things cannot reflect into the sky and change the sky's color. It may appear so at times such as when there is a forest fire. However, the glow from a fire actually acts like a huge flashlight. The light that is created by the fire is really reflecting off the clouds.
4. Answers will vary.

Pouring a Little Light on the Subject

1. The beam of light can be seen in the stream of water as it poured out of the cup. The beam of light entered the water and as the water poured out of the hole in the cup, the light reflected back and forth off the surface of the stream of water, going with the water as it left the cup. This effect is called total internal reflection.
2. Within the stream of water, the light reflected back and forth off the surface of the water.

Bendable Light

1. When an "S" shape was made, the light was able to bend with the shape because it reflected back and forth off the sides of the gelatin and came out the other end.
2. If the strips were "connected" tightly, the light should travel through both strips. If a gap were left, then the light would not have traveled through to the second strip of gelatin because the reflection would have been broken.
3. As you continued to sharpen the angle of the curves, the light eventually escaped because it struck the interior surface of the gelatin at too sharp an angle to be completely reflected.
4. Fiber optics is used for speeding information from place to place, such as via computer or telephone. Cable companies use fiber optics for better television reception, and fiber optics are even used in medicine and research.

Refraction Action

1. Waves do not bend as they travel through a medium. Waves travel in straight lines. However, when waves pass at an angle from one medium to another (air to water), they bend. The waves bend because the speed of the wave changes as the waves travel from one medium to another. Because waves move at different speeds in different densities, the waves bend. The bending of the waves is due to a change in speed and is called refraction.
2. Students may relate incidents such as when they were swimming and their feet looked "broken" or when they were diving for an object and it was not where they reached.
3. Answers will vary.

Multiple Monies

1. The least number of dimes was two.
2. The greatest number of dimes was 14.
3. The dimes multiplied by reflection. When positioned at different angles, each mirror reflects an image that can be reflected again and again. The closer the two mirrors are to each other, the more images they can reflect.

4. Answers will vary.

Transparent, Translucent, and Opaque

1. Answers will vary.
2. A cloudless, daytime sky appears transparent because you can see objects in the air. You can even see airplanes at high altitudes. However, on a cloudless night, you can see the stars. Is the sky during the day really transparent? If it is, where are the stars? Light entering the Earth's atmosphere is scattered by tiny particles suspended in the atmosphere. If there were no atmosphere and no particles to scatter light, we would see a sky similar to the night sky.
3. Astronauts see a sky similar to a night sky, but the Sun is shining. There is no atmosphere in space; therefore, there are no particles to scatter light. To see Apollo mission images, visit http://www.apolloarchive.com/apollo_gallery.html.

Blue, Blue, Where are You?

1. From the side the light looks bluish-white, but from the end and on the index card it looks yellow-orange.
2. The beam of light from the side became more yellow-orange, and the light on the index card became more orange-red because the milk created particles in the water that scattered the blue light.
3. The beam of light continued to become a darker yellow-orange, and the light on the index card became even redder because more particles were added to scatter more of the blue light. Eventually, if enough milk is added, the water becomes too cloudy for light to pass through.
4. As light enters the atmosphere, aerosols in the skies scatter light just like the milk particles. During the day, the sky is blue because the particles scatter the blue light. As the sun rises or sets, light has to travel through a thicker atmosphere (more particles), which scatters almost all the blue light, leaving visible only the reddish-orange light. Adding more milk to the container created a thicker "atmosphere" in the jar of water.

It's a Bird. It's a Plane. No, it's an Aerosol!

1. By taking an average of your weekly data, you are able to have a more accurate assessment of the number of aerosols in the atmosphere. Many variables can skew your data. For example, what if a truck with engine problems parked and ran his engine next to your data cards for 20 minutes? That would increase the number of aerosols for that day, but would not reflect a true picture of the atmosphere.
2. It is important to locate the cards in various locations to avoid the problem discussed in number 1. Multiple locations will give you better data.
3. Including other groups' data helps you see if your data are similar. It should be. More data also helps in case you miscounted the aerosols on the card.
4. No, because you do not have any data that tells you what a normal aerosol count consists of. You have nothing to compare your data to. However, if you knew that on an average day, the normal aerosol count was 150 and you had 500, you could assume that something was polluting your air.
5. Many different things could affect aerosol count, such as burning trash or forest fires in the area, a dry, hot, dusty day, or a release of pollutants from a factory.

The NASA "Why?" Files
The Case of the
Mysterious Red Light

Segment 3

In this segment, the tree house detectives are curious about the colors of a rainbow and decide that the spectrum of light might be their next clue. Dr. D introduces them to the visible spectrum and dispels the misconception that there are seven colors in the spectrum. He enlightens the tree house detectives to the true colors of the spectrum: red, orange, yellow, green, blue, and violet.

To learn more about the electromagnetic spectrum, the tree house detectives visit a NASA researcher at the Portsmouth Science Museum in Portsmouth, Virginia. Doreen Neil explains the electromagnetic spectrum and discusses frequency and wavelength. The detectives learn about the primary colors of light and pigment and explore a shadow box where they split light into its various colors.

Back at the tree house, KSNN reports that a volcano has erupted in the Pacific Ocean. The tree house detectives think that this might be the clue they have been looking for. To learn more about volcanoes, they get a little help from a NASA "Why?" Files Kids Club in Hampton, Virginia, Dr. Textbook, and Dr. Pieri, a NASA Researcher at NASA Dryden Flight Research Center in California.

Objectives

The students will

- learn the colors of the visible spectrum.
- understand the difference between the primary colors of light and pigment.
- calculate distance using a map scale and ruler.
- be able to differentiate between a cinder cone, a composite volcano, and a shield volcano.
- understand the relationship between plate tectonics, volcanoes, and the Ring of Fire.

Vocabulary

cinder cone - a type of volcano in which tephra (cinders) piles up into a steep-sided cone

composite volcano - a type of volcano built of lava and ash layers that accumulate from repeated cycles of tephra and lava eruptions. Also known as a stratovolcano.

diffraction grating - "super" prism that separates light of different wavelengths with a high resolution.

electromagnetic spectrum - forms of electromagnetic radiation that include radio waves, microwaves, infrared radiation, visible light, ultraviolet rays, X-rays, and gamma rays.

hot spot - areas in the Earth's mantle that are hotter than neighboring areas

lava - melted rock from a volcano flowing onto Earth's surface

mantle - largest layer inside Earth, lying directly above the outer core

map scale - the relationship between the distances drawn on a map and actual distances on Earth

mid-ocean ridge - an underwater mountain range that extends through the middle of most oceans, formed when forces within Earth spread the seafloor apart, causing it to buckle

Mt. Luminous - a fictitious volcano created for this program

plates - in plate tectonics, sections of Earth's lithosphere (crust and upper mantle)

plate tectonics - theory that states that Earth's crust and upper mantle are broken into sections called plates

primary colors of light - red, blue, green

primary colors of pigment - red, blue, yellow

prism - a transparent body with triangular bases used to split light into its spectrum of colors: red, orange, yellow, green, blue, and violet

pyroclastic debris - solids which can range in size from the finest dust to boulders that are blasted into the air by explosive volcanoes

Pacific Ring of Fire - the area around the Pacific Plate where earthquakes and volcanoes are common

scoria - extrusive volcanic rock formed from molten lava that cools quickly

shield volcano - a broad volcano with gently sloping sides, built by quiet eruptions of runny lava, which spreads out in flat layers

tephra - lava that is blasted into the air by violent volcanic eruptions and solidifies as it falls to the ground as ash, cinders, and volcanic bombs

visible spectrum - the only part of the electromagnetic spectrum we can see that includes the colors of the rainbow: red, orange, yellow, green, blue, and violet

volcano - a mountain that forms when layers of lava and volcanic ash erupt and build up over time



Video Component

Before Viewing

1. Prior to viewing Segment 3 of "The Case of the Mysterious Red Light," discuss the previous segment to review the problem and what the tree house detectives have learned thus far. Use the problem board to help sort the information.
2. Review the list of questions and issues that the students revised and/or created prior to viewing Segment 2. Determine which, if any, were answered in the video or in the student's own research.
3. Revise and correct any misconceptions that may have been dispelled during Segment 2. Use tools located on the web as previously mentioned in Segment 1.
4. Discuss the hypothesis that the students generated at the end of Segment 2 and decide if information learned supports their hypothesis. If not, discuss why and revise the hypothesis.
5. **Focus Questions** - Print the questions from the web site ahead of time for students to copy into their science journals. Encourage students to take notes during the show to answer the questions.

View Segment 3 of the Video

For optimal educational benefit, view *The Case of the Mysterious Red Light* in 15-minute segments.

After Viewing

1. At the end of Segment 3 have students reflect on the "What's Up?" questions asked at the end of the segment.
2. Discuss the hypothesis that the students generated at the end of Segment 2 and determine if they can continue to support it (Validation Station). At the end of Segment 2, the tree house detectives created a stronger hypothesis. Now, in Segment 3 after a KSNN report, they think that it might be a reflection from lava erupting from a volcano. Ask the students if the tree house detectives changed their hypothesis too quickly. What did they learn about reflection in Segment 2? Did the tree house detectives think the problem through

thoroughly? After learning more about volcanoes and finding out that Mt. Luminous is a cinder cone, the tree house detectives know that their hypothesis is wrong. They do not form a new one because they don't think they have enough information. Compare this decision to the one they made earlier in the segment when they changed their hypothesis very quickly. Ask the students why the tree house detectives think they need to wait.

3. Choose activities from the educator guide and web site to reinforce the concepts discussed in the segment. Pinpoint areas in your curriculum that may need to be reinforced or revisited and use activities to bolster students' understanding in those areas. Use the activities to "help" the tree house detectives solve the mystery. Help students see the correlation between the information learned and the clues used to solve the mystery.
4. Continue working on the problem-based learning activity on the web site. Have students use the Research Rack and the experiments located in Dr. D's Lab. Visit the Media Zone to learn more about the experts that were interviewed in this segment. Check out some of the great web sites referenced.
5. Have students reflect in their journal what they have learned from this segment and their own experimentation and research. If needed, give students specific questions to reflect upon.
6. Continue to assess what students have learned by using the students' journal writings, checklists, rubrics and other tools that can be found at the NASA "Why?" Files web site in the "Tools" section.

Careers

volcanologist
geologist
marine geologist
geophysical technician
seismologist
cartographer



Resources

Books

Tomecek, Stephen M. and Justine Ciovacco: *Discovery Channel School Teachers A-Z Resource Books: Light*. Discovery Communications, Inc., 2000, ISBN: 1563319837

Lauber, Patricia: *Volcano: The Eruption and Healing of Mount St. Helens*. Aladdin Paperbacks, 199e, ISBN: 0689716796

Lewis, Thomas P. and Joan Sandin: *Hill of Fire (I Can Read Books, Level 3 Series)*. Harper Collins Children's Books, 1987, ISBN: 0060238046

Lynch, David K. and Livingston, William: *Color and Light in Nature*. Cambridge University Press, 2001, ISBN: 0521772842

Owen, Weldon: *Reader's Digest Pathfinders: Earthquakes and Volcanoes*. Reader's Digest Children's Books, 2000, ISBN 1575843803

Silverstein, Alvin, Virginia Silverstein, and Laura Silverstein Nunn: *Plate Tectonics (Science Concepts)*. Twenty First Century Books, 1998, ISBN: 0761332251

Simon, Seymour: *Volcanoes*. Mulberry Books, 1995, ISBN: 0688140297

Van Rose, Susanna and James Stevenson: *Eyewitness: Volcano and Earthquake*. DK Publishing, 2000, ISBN: 0789457806

Web Sites

Imagine the Universe

An award-winning site created by NASA Goddard Space Flight Center for students ages 4-14. Visit "Gamma-Ray Bursts" for math, science, geography, and language arts activities for students in grades 5-8 that help them understand the electromagnetic spectrum. Take a look in "Imagine Science" for a whole spectrum of activities for the young student! <http://imagine.gsfc.nasa.gov/>

Volcanoes in Outer Space?

Earth isn't the only planet in our solar system with volcanoes. Learn more about volcanoes on other worlds in the kid's story "Volcanoes in Outer Space?" Download lesson plans that include Hot Lava

Poetry, Volcano Jeopardy, and a giant planet Pizza Party!
<http://www.thursdaysclassroom.com/03aug01/corner.html>

About Rainbows

Visit this site to learn how a rainbow forms and what makes the colors in a rainbow.
<http://www.unidata.ucar.edu/staff/blynds/rnbw.html>

The Sun, UV, and You—A SunWise Program

This program was created by the United States Environmental Protection Agency (EPA) to help children, parents, and educators become aware of the importance of sun safety. Become a SunWise School partner and receive FREE educational materials for your classroom or school. Learn about UV radiation and stratospheric ozone depletion and how these affect you everyday.
<http://www.epa.gov/sunwise>

FEMA for Kids: Volcanoes

This site includes general information about volcanoes, provides a map of the active volcanoes around the world, explains how to map lava flows, and more!
<http://www.fema.gov/kids/volcano.htm>

FEMA for Kids: Volcano Photos

http://www.fema.gov/kids/p_vol.htm

Volcano World

This site provides opportunities to learn about volcanoes through images and movie clips of volcanoes from around the world. Check out the most current eruptions and review the archive list of questions that were previously answered by volcanologists.
<http://volcano.und.nodak.edu/vw.html>

Volcano World: Volcano Images Around the World

http://volcano.und.nodak.edu/vwdocs/volc_images/volc_images.html

Light and Color @ Franklin Institute

This site explains how we see, how light travels, and how white light produces color.
<http://www.fi.edu/color/color.html>



Activities and Worksheets

In the Guide	Over the Rainbow Discover the colors and order of the visible spectrum.	42
	Spinning White Light Blend the colors of the rainbow to make white light.	43
	Primary Colors of Light Use the primary colors of light to make white light.	44
	Primary Colors of Pigment Mix the primary colors to discover secondary colors.	45
	Rainbow of Knowledge Create a book explaining the visible spectrum.	46
	Going the Distance Learn to use a map scale to measure distance.	47
	You've Got the Whole Egg In Your Hands Learn the layers of the Earth and the type of plate boundaries.	49
	The Three Little Volcanoes Learn about the three different types of volcanoes.	52
	The Ring of Fire Discover the Ring of Fire.	53
	Answer Key	56
On the Web	The Edible Spectrum Practice putting the colors of the visible spectrum in order and understand how frequency and wavelength are related to the order.	
	Magnificent Magma Make your own magma and discover its eruptive forces.	



Over the Rainbow

Purpose

To discover the colors and order of the visible spectrum

Procedure

1. Place the mirror in the plastic shoe box and lean it against one end.
2. Slowly pour water into the box until the mirror is covered halfway.
3. Hold the poster board above the box at the opposite end of the mirror.
4. Shine the flashlight on the water just in front of the mirror where the air, mirror, and water touch.
5. Adjust the mirror's angle until a rainbow's reflection appears on the poster board.
6. On your art paper, draw the rainbow, making sure to place the colors in the correct order.

Materials

clear plastic shoe box or
glass baking pan
9 x 12 in. white poster board
small mirror
ruler
white art paper
marker or crayons
water
flashlight

Conclusion

1. What are the colors of the rainbow? _____

2. How did the light, water, and mirror make a rainbow? _____

3. Where have you seen other "rainbows"? _____

Misconception

The visible spectrum has six colors: red, orange, yellow, green, blue, and violet. It was originally thought that the color indigo was between blue and violet. However, with more modern equipment, scientists now know there are only six colors. Therefore, Mr. ROY G BIV became Mr. ROY G BV.

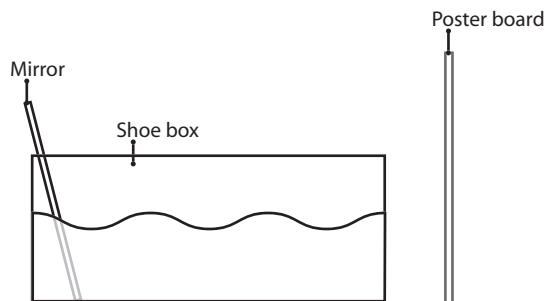

Spinning White Light

Purpose

To blend the colors of the visible spectrum to make white light

Procedure

1. Use the compass to draw a circle with a diameter of 15 cm on white poster board. See diagram 1.
2. Cut out the circle.
3. Divide the circle into six equal pie-shaped sections.
4. Color each section a different color using red, orange, yellow, green, blue, and violet. See diagram 2.
5. Use the pointed end of the compass to make two small holes on opposite sides of the center of the circle. They should be about 3 cm apart from each other. See diagram 3.
6. Thread the string through the holes and tie the ends of the string together so that the thread forms a loop. See diagram 4.
7. Center the circle on the thread, wind up the circle, and make it spin by alternately stretching and relaxing the string.

Materials

compass
 metric ruler
 scissors
 pencil
 crayons or markers
 1 m of string

Extensions

1. Sometimes spinning the circle on a string is too difficult for younger students. To make it easier to spin, use the compass to punch a hole in the center of the circle and put the circle on the end of a sharpened pencil. Use tape to help hold it in place. Have students rub the pencil between their two palms to make the circle spin back and forth.
2. Make multiple circles. Divide one circle into three sections and color it red, blue, and green. Divide another circle into three sections and color it red, blue, and yellow. Divide other circles into various numbers of sections and try different combinations of colors.

Conclusion

1. How is color related to white light? _____

2. What was the purpose of spinning the circle? _____

3. What would happen if you put only red, blue, and yellow on the circle and spun it? _____

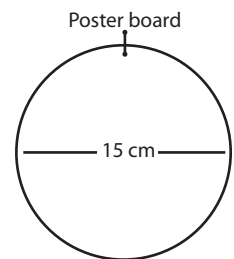

Diagram 1

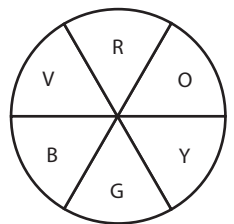

Diagram 2

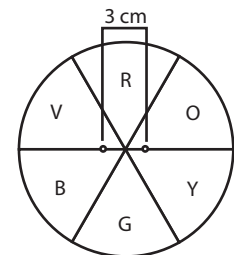

Diagram 3

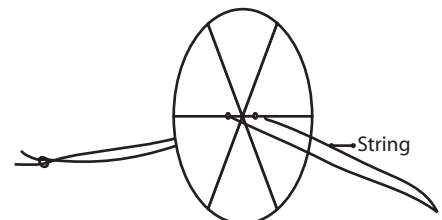

Diagram 4

Primary Colors of Light

Purpose

To blend the primary colors of light to make white light

Procedure

1. Make a template by placing flashlight bulb-side down onto a piece of paper and tracing around the outer edge.
2. To slightly enlarge the circle, cut around the outside edge of the circle.
3. Use this circle as a template to cut out circles from the cellophane paper. Cut one of each color.
4. Tape the red cellophane circle to one flashlight, the blue cellophane circle to the second, and the green cellophane circle to the third.
5. In a darkened room, shine each flashlight onto the poster board.
6. Mix the colored lights in various combinations.
7. Record your observations in your science journal.

Materials

three flashlights
red, blue, and green
cellophane
tape
white poster board
paper and pencil
scissors
journal

Conclusion

1. What combination of colors made white light? _____

2. What are the primary colors of light? How do you know? _____

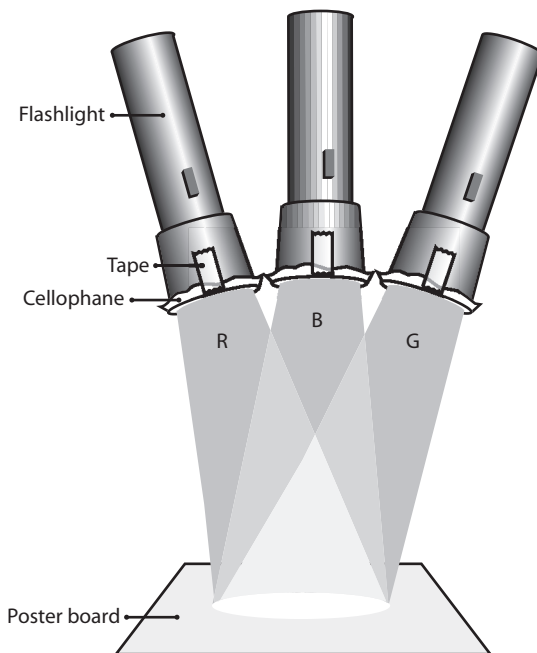

Primary Colors of Pigment

Purpose

To use the primary colors of pigment to discover the secondary colors

Procedure

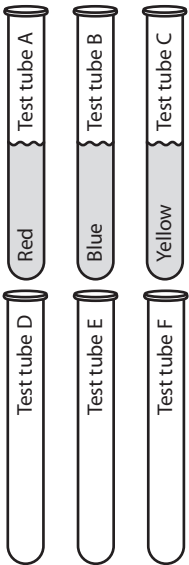

1. Fill three test tubes half full with water.
2. Use the marker and label each test tube "A," "B," and "C."
3. Place 5 drops of red food coloring in test tube "A."
4. Place 5 drops of blue food coloring in test tube "B."
5. Place 5 drops of yellow food coloring in test tube "C."
6. Allow the color to mix thoroughly. A gentle shake will help to mix them faster.
7. Use the marker and label the remaining three test tubes "D," "E," and "F."
8. Pour 1/2 the water from test tube "A" into test tube "D."
9. Pour 1/2 the water from test tube "B" into test tube "D."
10. Place thumb over the opening of the test tube and gently shake.
11. Record your observations on data chart.
12. Pour remaining water from test tube "A" into test tube "E."
13. Pour 1/2 the water from test tube "C" into test tube "E."
14. Gently shake and record observations in data chart.
15. Pour remaining water from test tubes "B" and "C" into test tube "F."
16. Gently shake and record observations in data chart.
17. Draw conclusions and discuss.

Materials

- food coloring (red, blue, and yellow)
- 6 test tubes or jars
- test tube rack
- water
- pencil
- marker or grease pencil

Data Chart

Test Tube D	Test Tube E	Test Tube F
Red + Blue = _____	Red + Yellow = _____	Blue + Yellow = _____

Rainbow of Knowledge

Depending on the number of pages you need, cut out several rainbows. Punch a hole at the circle indicated in the cloud and connect with string or fastener to create a book. In your book explain the visible spectrum.

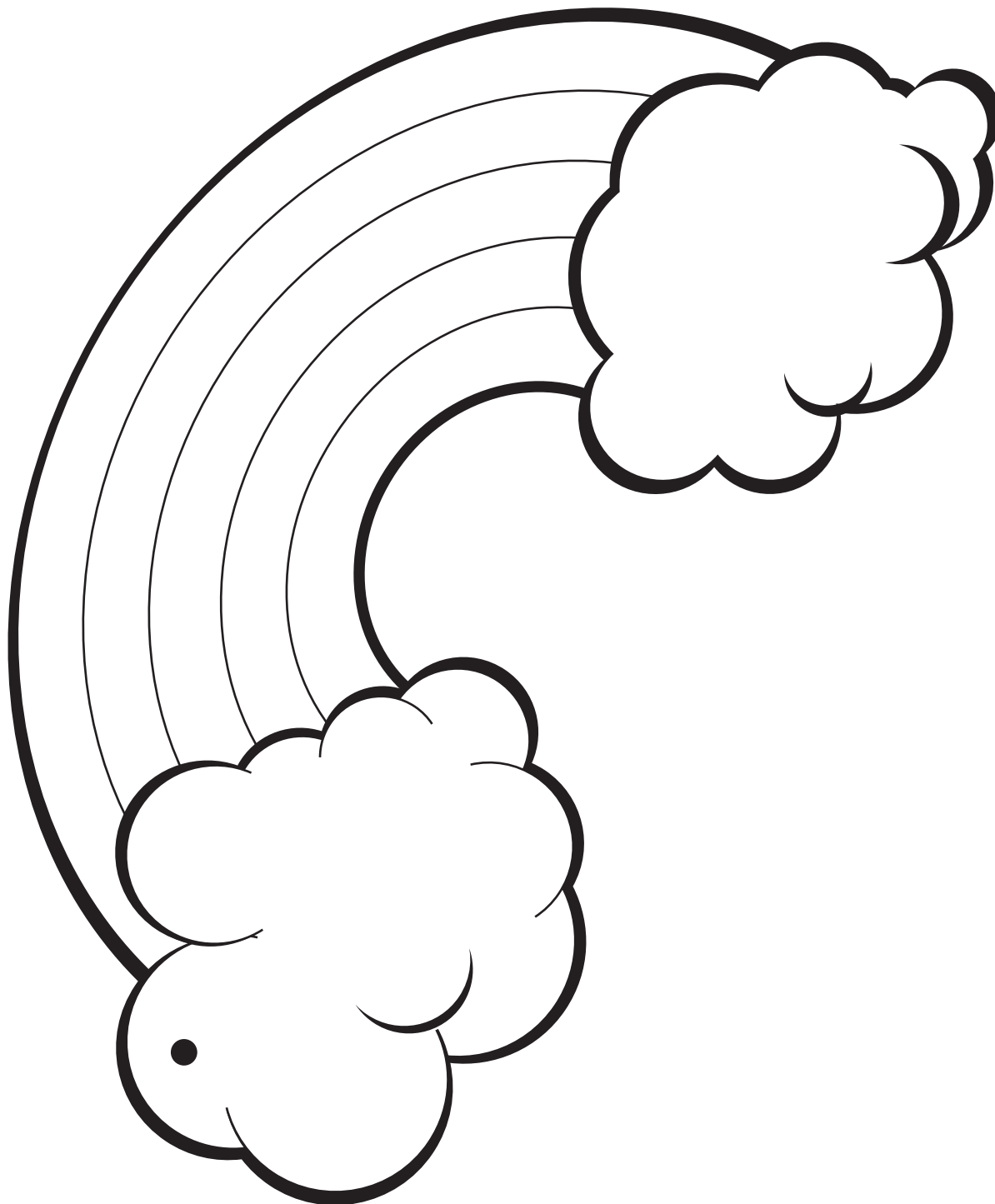

Going the Distance

Purpose

To use a map scale to measure and calculate distance

Procedure

1. Study the map and locate the compass rose and map scale.
2. Look at the map scale and determine the number of kilometers per centimeter.
3. Calculate the distance "as the crow flies" between Miami and Houston and record in your journal. Determine the direction that you "flew" and record.
4. Determine the length of time that it would take to fly from Miami to Houston if flying at a speed of 150 km per hour. Record in your journal.
5. Estimate the distance between Miami and Hawaii and record.
6. Repeat step 3 for the distance between Miami and Hawaii and compare to your estimation.
7. If Mt. Luminous was located near the Hawaiian Islands, how long would it take for dust and ash to reach Miami if it traveled at 100 km per hour? How many days would it take?
8. Use a globe and find the map scale. Measure the distance between Miami and Hawaii on the globe. Calculate and record.
9. Is it the same as the distance on your map? Explain why or why not.
10. Use an atlas or other map with a scale to calculate the distance between Miami and Hawaii. Record. Is the distance the same as the globe or your map? Why or why not?

Materials

map sheet
atlas
globe
metric ruler
pencil
journal

Conclusion

1. Explain why various maps and globes differ in the number of kilometers between Miami and Hawaii. _____

2. Explain why approximating distance is valid in some instances, but not in others. _____

3. Is Hawaii closer to Houston or Great Falls? _____
4. Which city is the most northern? _____
southern? _____
eastern? _____
western? _____



Going the Distance

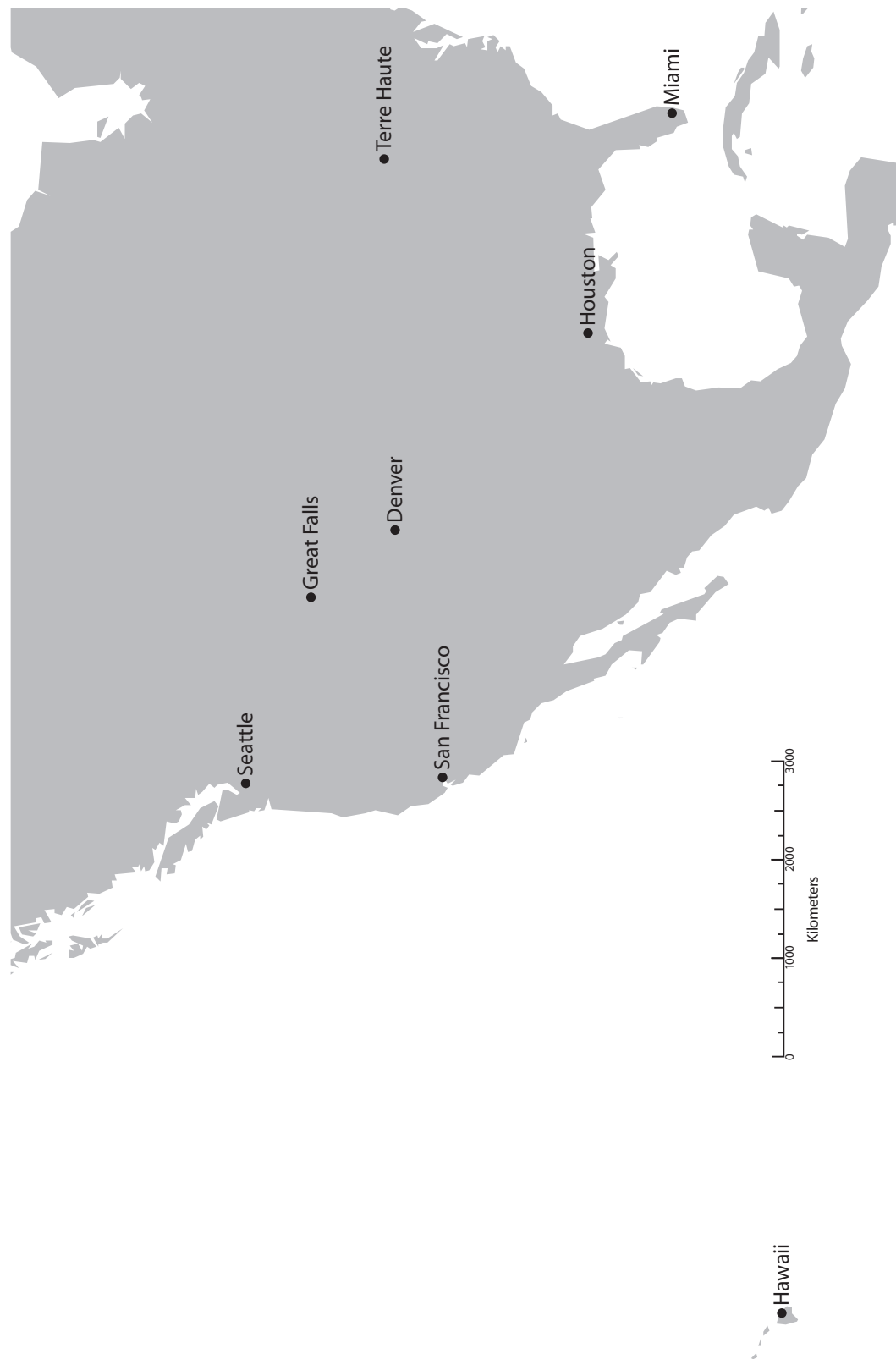

You've Got the Whole Egg in Your Hands

Purpose

To learn the layers of our Earth
To learn the types of plate boundaries

Procedure

1. Have students examine the hard-boiled egg and discuss that it is a model of the Earth.
2. Discuss that the outer shell of the egg represents the crust of our Earth. Explain that our crust is broken into several large pieces and that there are seven major plates of the lithosphere. To create plates on the egg model, have students gently tap the egg on a hard surface.
3. Have the students examine the egg and count the number of plates created. Use a marker to outline the plates.
4. Discuss with the students that the plates are always moving. Ask students to demonstrate three ways that they can make their eggs' plates move. They should derive that they can push them together, pull them apart, and twist them. Introduce the three types of movement that occur at the plate boundaries or zones. The level of discussion will depend upon the level of your students.

divergent boundary - boundary between two plates that are moving apart from one another. The Mid-Atlantic Ridge is an example of a divergent boundary. Demonstrate by gently pulling on the ends of the egg, causing the plates to spread apart.

convergent boundary - boundary where two plates collide. Have students gently push on each end of the egg to demonstrate. There are three types of convergent boundaries:

The first is an area where a **heavier ocean plate goes under a lighter continental plate**, creating a subduction zone. Volcanoes occur at subduction zones. The Andes Mountains were formed in this manner.

The second is an area where **two ocean plates collide** and one bends and slides under the other, creating a subduction zone that forms a deep-sea trench. Volcanoes form underwater at this boundary forming islands such as Japan.

The third is an area where **two continental plates collide** and crumple up forming mountain ranges such as the Himalayas.

transform fault boundary - occurs when two plates slide past one another moving in opposite directions or in the same direction at different rates. Gently twist the ends of the egg to demonstrate transform faults. A famous transform fault boundary is the San Andreas Fault in California.

5. Have students use the plastic knife to cut the egg in half.
6. Discuss the layers of the Earth as represented by the layers of the egg. The white part of the egg represents the mantle and the yolk is the core. The inner core and the outer core can be differentiated by the darker color around the outer part of the yolk. Point out the thin membrane between the shell and the yolk. This part is representative of the asthenosphere. It is on this plastic-like layer that the plates of the crust move.
7. Have the students complete the activity sheet "Layers of the Earth" and perform the research suggested.
8. Have the students complete the activity sheet "Plates and More Plates" and conduct the suggested research.

Materials

hard-boiled egg
paper towels
plastic knife
activity sheets

You've Got the Whole Egg in Your Hands

Activity Sheet: The Layers of the Earth

Look at the diagram and label the layers of the Earth using outer core, inner core, mantle, crust, and asthenosphere.

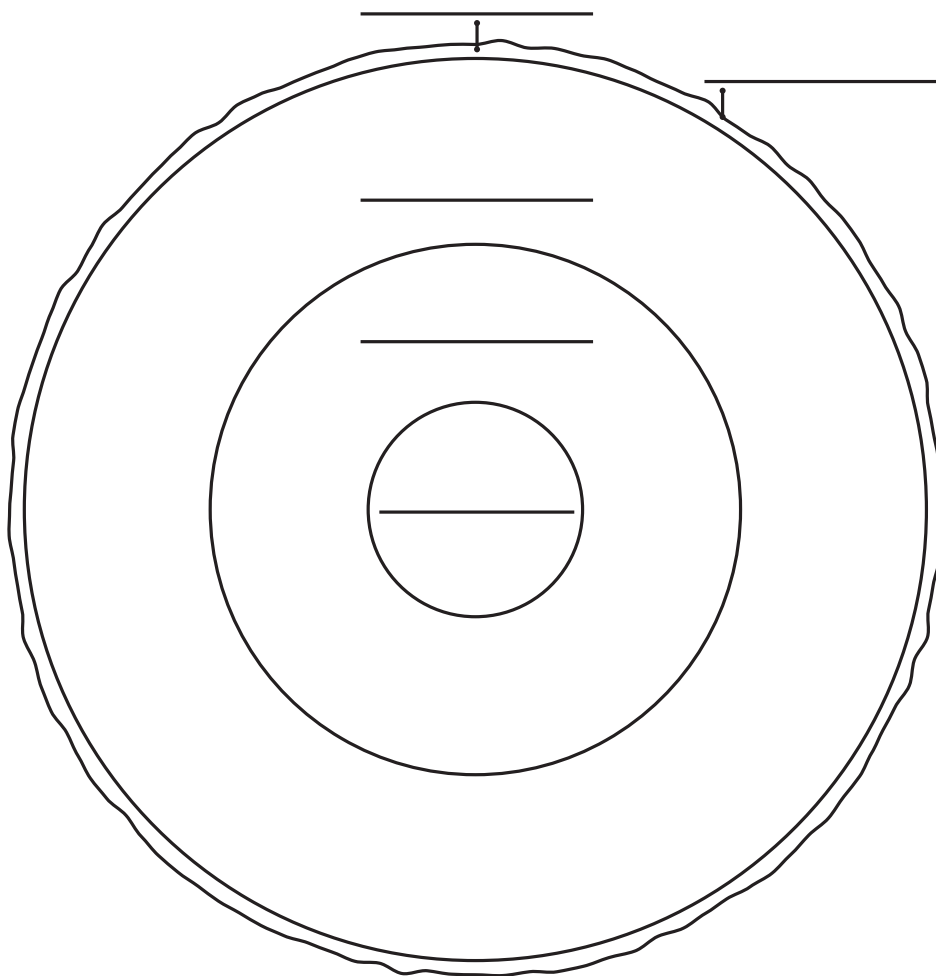

Research for more information about the layers of the Earth. On the back of this sheet, list three facts about each layer and share with your class.

You've Got the Whole Egg in Your Hands

Activity Sheet: Plates and More Plates

Look carefully at the diagrams below. With the information you have about plates and their movements, identify each of the plate boundaries using divergent, convergent, or transform faults.

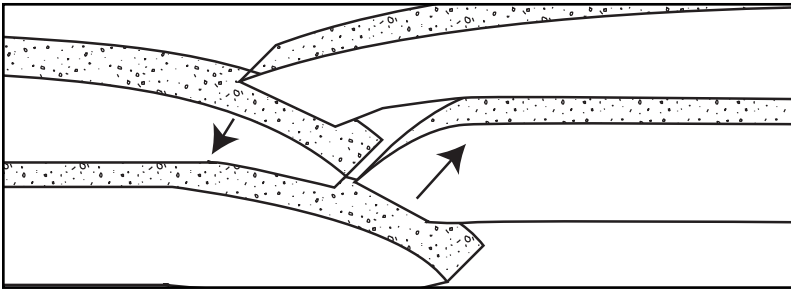

1. _____

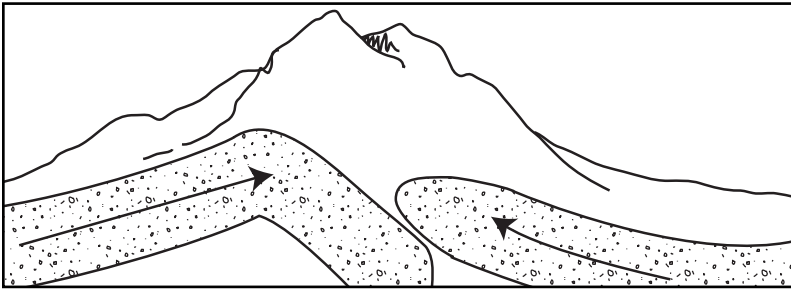

2. _____

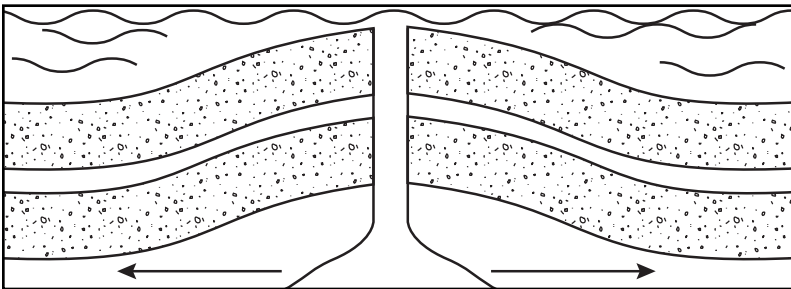

3. _____

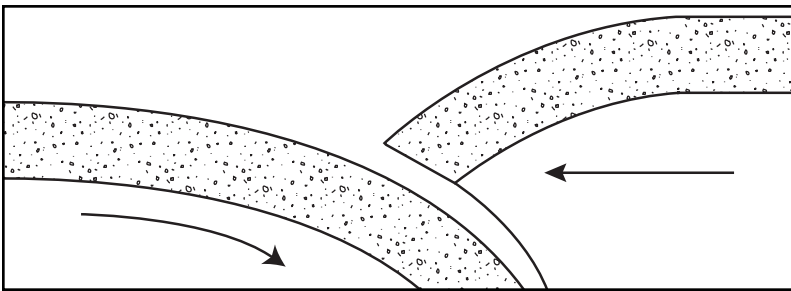

4. _____

Research plate boundaries to discover how volcanoes are formed.

Research to discover the name of the seven major plates.

Research to discover what makes the plates move.

The Three Little Volcanoes

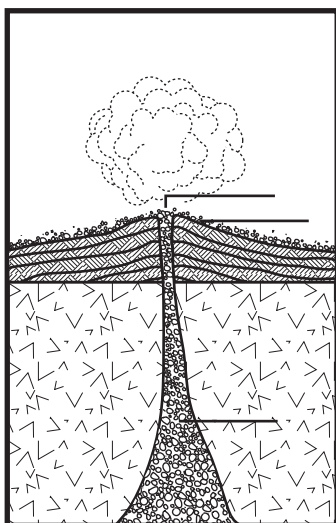

Shield volcanoes are shaped like shields and have very gentle, sloping sides. They are made of many layers of a kind of volcanic rock (basalt) that flows very easily when melted. The melted rock is called magma, and when it flows out the vent it becomes lava. The lava forms thick layers that slope away from the vent. These layers then cool and harden over time. Shield volcanoes can be very large. The volcanoes of Hawaii are shield volcanoes that have formed over a hot spot in the crust. Label the diagram using letters to represent vent (A), magma (B), and lava (C). Color the lava and magma red, the layers of hardened lava yellow, and the preexisting rocks brown.

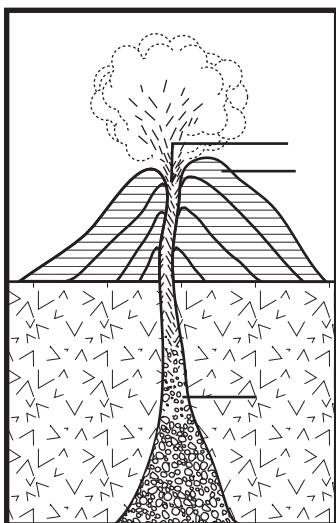

Cinder cone volcanoes are made of pieces of rock called tephra. Tephra may be tiny like dust and ash or large like gravel. Tephra blows out the vent and cools so quickly that it hardens before hitting the ground. When tephra falls to the ground, it piles up around the vent, forming a steep cone. Cinder cones are often smaller than shield volcanoes, and they can erode very easily. In a Mexican corn field, a cinder cone called Parícutin grew several hundred meters high in just a few days! Label the diagram using letters to represent vent (A), magma (B), and lava (C). Color the tephra orange, the layers of tephra gray, the magma red, and the preexisting rocks brown.

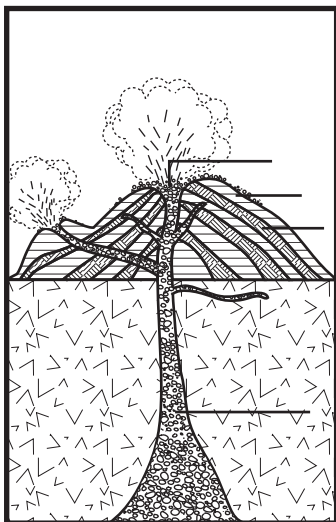

Composite volcanoes are formed when eruptions vary between quiet and explosive. These eruptions create alternating layers of lava and tephra. During explosive eruptions, tephra is released. During quiet eruptions, lava is released. The layers of tephra make the sides steep, and the layers of hardened lava help keep the volcano from eroding quickly. Composite volcanoes are found mostly at convergent plate boundaries. Mt. St. Helens is an example of a composite volcano. Label the diagram using letters to represent vent (A), magma (B), lava (C), and tephra (D). Color the magma and lava red, the tephra layers gray, the hardened lava layers yellow, the gas and dust orange, and the preexisting rocks brown.

The Ring of Fire

There are more than 1,500 active volcanoes in the world. An active volcano is one that has erupted at least once in the past 10,000 years and is likely to erupt again. Because most of the Earth's volcanoes are hidden under the oceans, people have not been able to witness their eruptions. Every year about 50-60 volcanoes erupt on land where people might be able to see them. Scientists estimate that there are about 200 volcanic eruptions under the oceans. The shaded area on the map is called the "Ring of Fire." Do the exercise below and you will discover why.

Materials

compass
 metric ruler
 scissors
 pencil
 crayons or markers
 1 m of string

Directions

Locate and label each of the volcanoes listed on the blank map. Make a key and use a different colored marker for stratovolcano (composite), shield, and cinder cone volcanoes.

This is a list of some active, or recently active, volcanoes.

Name	Type	Last Erupted
1 Azul	Stratovolcano	1967
2 Bezymianmy	Stratovolcano	1993
3 Cerro Negro	Cinder cone	1971
4 Cotopaxi	Stratovolcano	1942
5 Erebus	Stratovolcano	1980
6 Katmai	Stratovolcano	1912
7 Kilauea	Shield	1995
8 Krakatau	Stratovolcano	1894
9 Ksudach	Shield	1907
10 La Palma	Stratovolcano	1954
11 Lassen Peak	Stratovolcano	1914
12 Mt. Etna	Shield	1993
13 Mt. Fuji	Stratovolcano	1709
14 Mt. Pelée	Stratovolcano	1932
15 Mt. Rainier	Stratovolcano	1894
16 Mount St. Helens	Stratovolcano	1986
17 Nevada del Ruiz	Stratovolcano	1991
18 Ol Doinyo Lengai	Stratovolcano	1993
19 Parícutin	Cinder cone	1952
20 Pinatubo	Stratovolcano	1992
21 Sunset Crater	Cinder cone	1065
22 Surtsey	Shield	1967
23 Tambora	Stratovolcano	1967
24 Vesuvius	Stratovolcano	1944



Ring of Fire

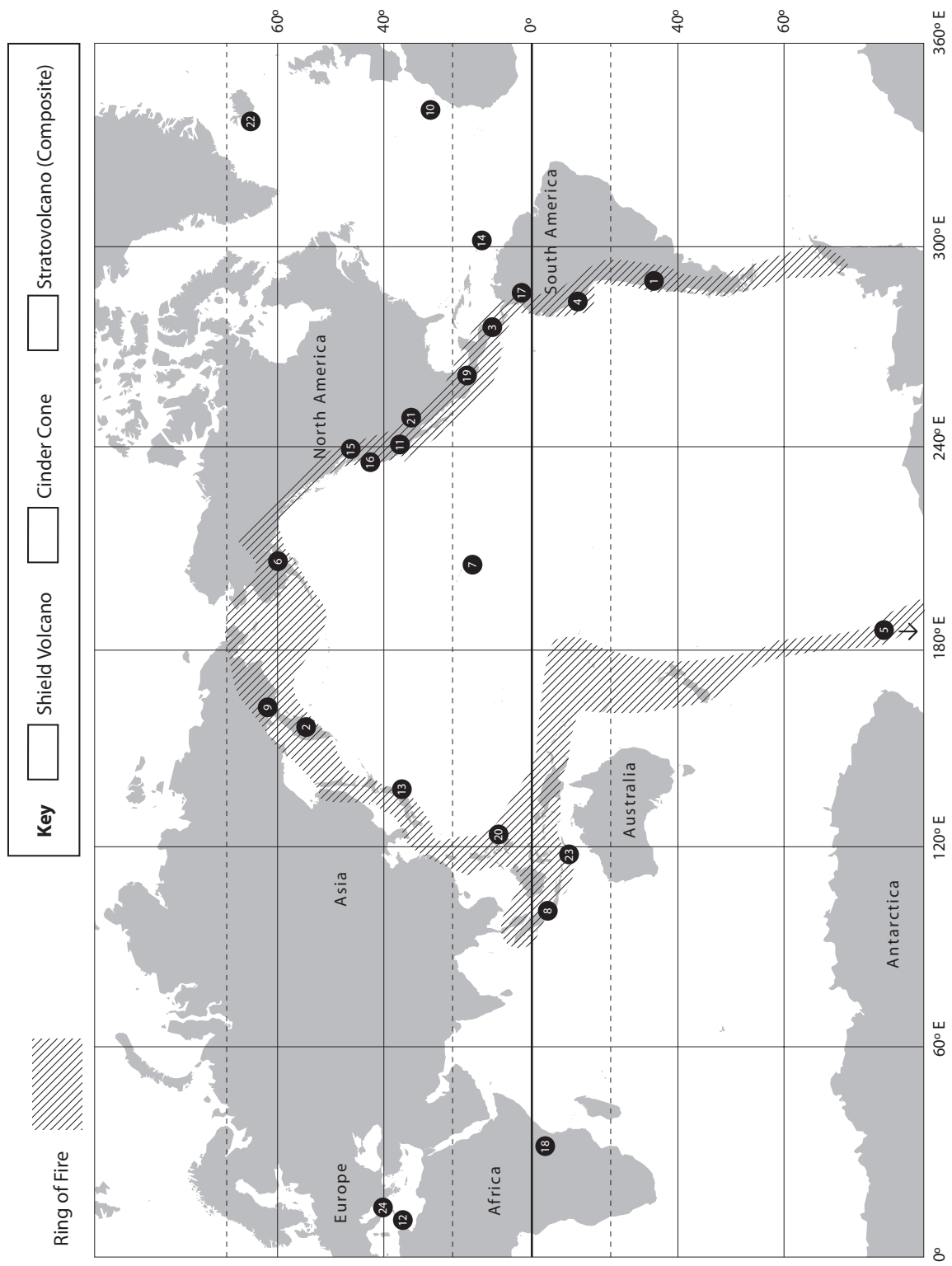

Answer Key

Over the Rainbow

1. red, orange, yellow, green, blue, and violet (purple)
2. The light hit the wedge of the water between the mirror and the water's surface, causing the light to bend (refract). Since each wavelength of light bends at a different angle, the colors are refracted in slightly different directions, and the colors are spread out or split, creating a rainbow.
3. Rainbows may have been seen in the sky, on bubbles, CDs, dish soap, or many other places.

The Edible Spectrum

1. The wavelengths should have been determined by determining each color's frequency. Red has the slowest frequency; therefore, it has the longest wavelength. Violet has the highest frequency; therefore, it has the shortest wavelength. The other colors would fall in between, graduating from longer to shorter, as determined by their order in the spectrum.
2. The relationship is that the longer the wavelength, the slower the frequency and the shorter the wavelength, the faster the frequency.
3. The candy pieces represent the photons.

Spinning White Light

1. White light is the combination of all the colors of light.
2. When the circle was not spinning, your eye could tell the colors apart. The only way to get the colors to blend is to spin the circle so that the colors move so fast that it becomes impossible for the eye to tell them apart. The six colors blend and appear yellowish white.
3. You would have gotten a different color and not white light because those are not the colors of light nor are they the complete colors in the spectrum.

Primary Colors of Light

1. White light was produced when red, green, and blue were combined.
2. The primary colors of light are red, green, and blue because they were the three colors that produced white light. None of the other color combinations worked.

Going the Distance

1. Maps will vary slightly in distance because it is very difficult to calculate accurately on very large-scale maps such as globes. The smaller the map scale, the more accurate measurements will be.
2. It is valid to approximate distance if you just need a rough estimate. However, if you are a pilot, for example, and need to know when you will be landing at your destination, a more accurate measurement of distance is required.
3. Hawaii is closer to Great Falls.
4. Northern—Seattle, Southern—Miami, Eastern—New York, Western—San Francisco

Magnificent Magma

1. The squeezing of your hand represented the pressure inside the Earth that builds up to force magma out onto the surface of the Earth (lava).
2. The space between your fingers represented the cracks in the Earth's crust that allow the magma to erupt onto the surface of the Earth.
3. The wider the crack, the more magma can erupt. The more force applied, the more violent the eruption.
4. No, because it is a cinder cone, and cinder cones do not erupt magma, just cinders.



The NASA "Why?" Files
The Case of the
Mysterious Red Light

Segment 4

The tree house detectives are certain that the unusually bright red sunrises and sunsets are being caused by a large amount of aerosols in the atmosphere. However, they are puzzled as to what could be causing an influx of aerosols. With Mt. Luminous over 7,000 miles away from Virginia, the tree house detectives rule out its recent eruption of dust and ash, but decide that they had better make certain. They visit with Jennifer Olson of Atmospheric Sciences at NASA Langley Research Center and learn that aerosols can be carried long distances by upper atmospheric winds. It dawns on them that Mt. Luminous just might be the illuminating clue they need to solve the mystery!

After calculating wind speed and distance to determine the length of time it would take for aerosols to travel to Virginia, the tree house detectives once again are afraid they have come to a dead end. After remembering what they learned about the jet stream, the tree house detectives visit Fred Yco, a meteorologist with WAVY News 10 in Norfolk, Virginia. Mr. Yco confirms that the jet stream has been flowing in a pattern that would have brought the aerosols to Virginia in only three days! E-mails from students across the United States confirm their hypothesis, and *The Case of the Mysterious Red Light* is just one more for the files.

With the mystery solved, the tree house detectives visit Dr. D and review their case and the scientific process that they followed. Jacob tries one final magic trick, and suddenly the tree house detectives disappear into the sunset, or was it just an illusion?

Objectives

The students will

- learn that wind vectors represent the speed and direction of wind.
- learn that wind travels in global wind patterns.
- learn that the Earth's atmosphere is divided into layers.
- calculate distance and average wind speed to determine length of time for a particle to travel.
- learn that the jet stream is a river of air in the upper atmosphere.

Vocabulary

CAVE - Cave Automated Virtual Environment. A room with 4 screens (3 walls and a floor) that enables an observer to experience a computer generated projection in a three-dimensional environment.

global wind pattern - Earth's general circulation pattern of wind created by the unequal heating of the Earth's surface and by the rotation of the Earth

jet stream - a narrow belt of strong, high-pressure, fast moving (up to 350 km per hour) air flowing from west to east in the troposphere

stratosphere - A layer of Earth's atmosphere just above the tropopause, extending from about 15 km above Earth to about 50 km. Airplanes travel in this layer and the ozone layer is located here.

wind - horizontal movement of air over the Earth's surface that is created when cool, heavy air moves toward warm, light air

vector - a quantity in which both the magnitude and direction must be stated

Video Component

Implementation Strategy

The NASA "Why?" Files are designed to enhance and enrich the existing curriculum. Full use of the video, resources, activities, and web site usually requires two to three days of class time per segment.

Before Viewing

1. Prior to viewing Segment 4 of *The Case of the Mysterious Red Light*, discuss the previous segment to review the problem and what the tree house detectives have learned thus far. Record on problem board.
2. Review the list of questions and issues that the students revised and/or created prior to viewing Segment 3. Determine which, if any, were answered in the video or in the student's own research.
3. Revise and correct any misconceptions that may have occurred during Segment 3. Use tools located on the web, as previously mentioned in Segment 1.

4. Discuss the hypothesis that the students generated at the end of Segment 3 and decide if information learned supports their hypothesis. If not, discuss why and revise the hypothesis.
5. **Focus Questions** - Print the questions from the web site ahead of time for students to copy into their science journals. Encourage students to take notes during the show to answer the questions.

View Segment 4 of the Video

For optimal educational benefit, view *The Case of the Mysterious Red Light* in 15-minute segments and not in its entirety.

After Viewing

1. Lead students in a discussion to reflect upon the solution to the mystery.
2. Discuss the hypothesis that the students generated at the end of Segment 3 and determine if their hypothesis was correct. Discuss why the tree house detectives spoke to



an atmospheric researcher at NASA. Why did the tree house detectives need to know about wind patterns? The new "hypothesis" was, "If the zonal winds carried the dust and ash from the volcano to our area, then we would have red sunsets and sunrises." Why did Jason begin to doubt their hypothesis? How did a meteorologist help them to know that they were on the right track? The tree house detectives received E-mails from all across the United States. How did the E-mails help them know they had solved the mystery?

3. Choose activities from the educator guide and web site to enhance and enrich the concepts discussed in the segment. Help students see the correlation between the information learned and the clues that were used to solve the mystery.
4. Complete the problem-based learning activity on the web site.
5. Ask the students to recount the steps the tree house detectives took to solve the mystery. How many times did the tree house detectives revise their hypothesis? Why did they keep revising it?
6. Continue to assess students' performance and thinking as appropriate by reviewing the

Careers

atmospheric scientist
meteorologist
meteorologist technician

students' journal writings. Evaluate the final product that was generated to represent the online PBL activity by using the rubric that best fits the

products produced. Sample rubrics and other tools can be found at the NASA "Why?" Files web site in the "Tools" section of the educator's area.

Resources

Books

Allaby, Michael: *How the Weather Works*. Reader's Digest Adult, 1999, ISBN: 0762102349

Cosgrove, Brian, Karl Shone, and Keith Percival: *Eyewitness: Weather*. DK Publishing, 2000, ISBN: 0789457822

Farndon, John and John Bendall-Brunello: *Eyewitness Explorers: Weather*. DK Publishing, 1998, ISBN: 0789429853

Moreau, Roger: *Volcano and Earthquake Mazes*. Sterling Publications, 2000, SBN: 0789457806

Onish, Liane: *Wind and Weather: Climates, Clouds, Snow, Tornadoes, and How Weather is Predicted* (Scholastic Voyages of Discovery. Natural History. Scholastic Inc., 1994, ASIN: 0590476467

Watt, Fiona and Francis Wilson: *Weather and Climate (Science and Experiment Series)*. Usborne Publishing Ltd., 1992, ISBN: 0746006837

Web Sites

NASA Langley Research Center/Earth Science

Learn about present and future atmospheric science programs conducted at NASA Langley Research Center.

http://www.larc.nasa.gov/research/inside_pages/earthscience.htm

NASA Langley Research Center/Earth Science/Learning Center

Fantastic site for all your atmospheric needs. Learn about the layers of the atmosphere, aerosols, ozone depletion, global warming, radiation budget, volcanoes, and much more. It has a comprehensive glossary of terms, a time conversion chart, and additional links.

<http://www-sage3.larc.nasa.gov/solar/learningindex.html>

The CERES S'COOL Project

Primary and secondary school teachers and their classes are invited to participate in this ongoing weather data collection project. Your class observations, comparisons, and evaluations will become part of the real data used by researchers at NASA Langley Research Center in Hampton, VA.

The Weather Classroom

The Weather Channel's education site for teachers and students. Learn the weather term for the day, study hurricanes, and learn to forecast the weather. <http://www.weather.com/education/index.html>

NOAA (National Oceanic and Atmospheric Administration) Education Resources

An abundance of weather related activities. Teacher, parent, and student sections.

<http://www.education.noaa.gov/>

"gettech"

A cool place to learn about careers in math and technology. Includes sections for teachers, parents, and students.

<http://www.gettech.org>

Videos

Eyewitness: Volcano. DK Vision, 1996, ISBN: 0789407213



Activities and Worksheets

In the Guide	How Fast Does She Blow? Discover the Beaufort Wind Scale.62
	Global Winds Use clues to learn where the global wind belts are located.63
	Layer Upon Layer Learn the order of the atmospheric layers64
	Layers of the Atmosphere Identify the boundaries of the atmospheric layers65
	Riding the Jet Stream Follow the jet stream to discover this wondrous river of air.67
	Tracking an Ash Cloud As an air traffic controller, it is important to track a cloud of volcanic dust and calculate its arrival time for airplane safety.68
	Answer Key70
On the Web	As the World Turns Learn how the rotation of the Earth causes global wind patterns.	







How Fast Does She Blow?

Purpose

Learn to differentiate between wind speeds by using the Beaufort Scale of Wind Force

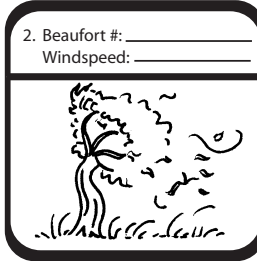
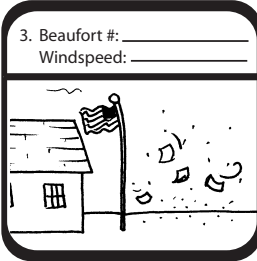
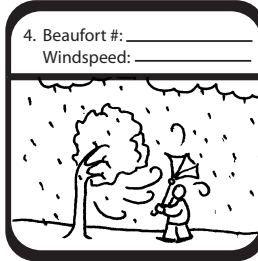
Beaufort Scale (modified)				
Wind Speed Mph	Beaufort Scale	Wind Description	Wind Effects	Wind Vector
1	0	Calm	smoke rises vertically	
4 - 7	2	Light breeze	wind felt on face; leaves rustle; wind vane moves	
13 - 18	4	Moderate breeze	raises dust, loose paper; small branches move	
25 - 31	6	Strong breeze	large branches move; umbrellas used with difficulty	
39 - 46	8	Gale	breaks twigs off of trees	
55 - 63	10	Storm	trees uprooted; damage to coast	
74+	12	Hurricane	widespread damage	

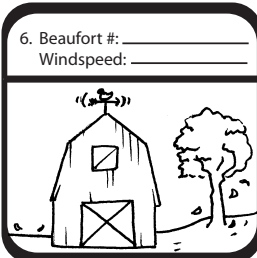
Use the chart above to determine the appropriate Beaufort Scale.

1. Beaufort #: _____ Windspeed: _____ 	2. Beaufort #: _____ Windspeed: _____ 	3. Beaufort #: _____ Windspeed: _____ 	4. Beaufort #: _____ Windspeed: _____ 
5. Beaufort #: _____ Windspeed: _____ 	6. Beaufort #: _____ Windspeed: _____ 	7. Beaufort #: _____ Windspeed: _____ 	8. Beaufort #: _____ Windspeed: _____ Draw your own.

Conclusion

1. The CAVE at NASA Langley Research Center depicted a 3-D model of wind vectors—the longer the vector, the faster the wind. In the last column of the Beaufort Scale, draw wind vectors that might be used in the CAVE.

2. On a normal day, how fast does the wind blow? What would normal be on the Beaufort Scale?

3. Wind vectors also show direction. How could you show the direction of the wind? _____

Global Winds

Wind is the movement of air molecules from an area of high pressure to an area of low pressure. The uneven heating of the Earth's surface by the Sun creates these differences in pressure. The uneven heating is due to the Earth's surface being curved rather than flat. Because of the curved surface, not all areas receive the same amount of radiation from the Sun. Thus, the air above the equator is heated more than at any other place on Earth. The air at the poles is much colder. As the warm air rises from the equator, cold dense air sinks from the poles and moves along the surface of the Earth toward the equator. As the Earth rotates, the Coriolis effect is created. In the northern hemisphere, the Coriolis effect causes air masses to turn westward from their original path. In the southern hemisphere, the air masses deflect eastward. These deflections create wind belts.

Use the clues to correctly label the wind belts on the diagram of the Earth. Color as designated.

1. The Prevailing westerlies are located between 30° and 60° latitude. Color yellow.
2. The Polar easterlies are located above and below 60° latitude. Color blue.
3. The trade winds are located between 0° and 30° latitude. Color orange.
4. The horse latitudes are located at 30° South and North latitudes. Color red.
5. The doldrums are located at 0° latitude. Color black.

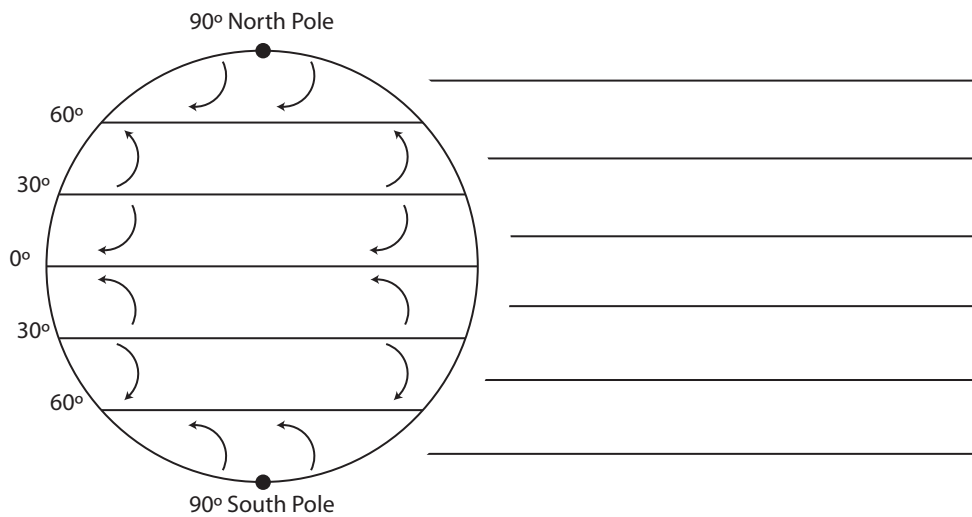

Conclusion

1. Within which wind pattern does the United States lie? _____
2. What general direction does the wind blow in the United States? _____
3. How did learning about the global wind patterns help the tree house detectives solve the mystery? _____

4. How do wind patterns affect our weather patterns? _____

Layer Upon Layer

Purpose

To learn the order of the layers of the atmosphere

Procedure

1. On the Earth disk, color the water blue and the land brown.
2. Color the troposphere blue, the stratosphere yellow, the mesosphere orange, the thermosphere pink, and the exosphere purple.
3. Cut out the circles.
4. Punch a hole in each layer at the center mark. Optional: If glue is used, do not punch holes. Place a drop of glue at the center mark of each circle and follow the directions in Step 5.
5. Using the holes (center marks) as a guide, center the layers in a graduated order from largest to smallest (the exosphere on the bottom and the Earth on the top).
6. Use a brass fastener to fasten all layers together.

Materials

disks
markers
scissors
brass fastener
hole punch
journal
glue (optional)

Conclusion

1. Which layer is closest to the Earth? _____
2. Which layer is farthest from the Earth? _____
3. Along which layer of the atmosphere did the volcanic ash from Mt. Luminous travel? _____

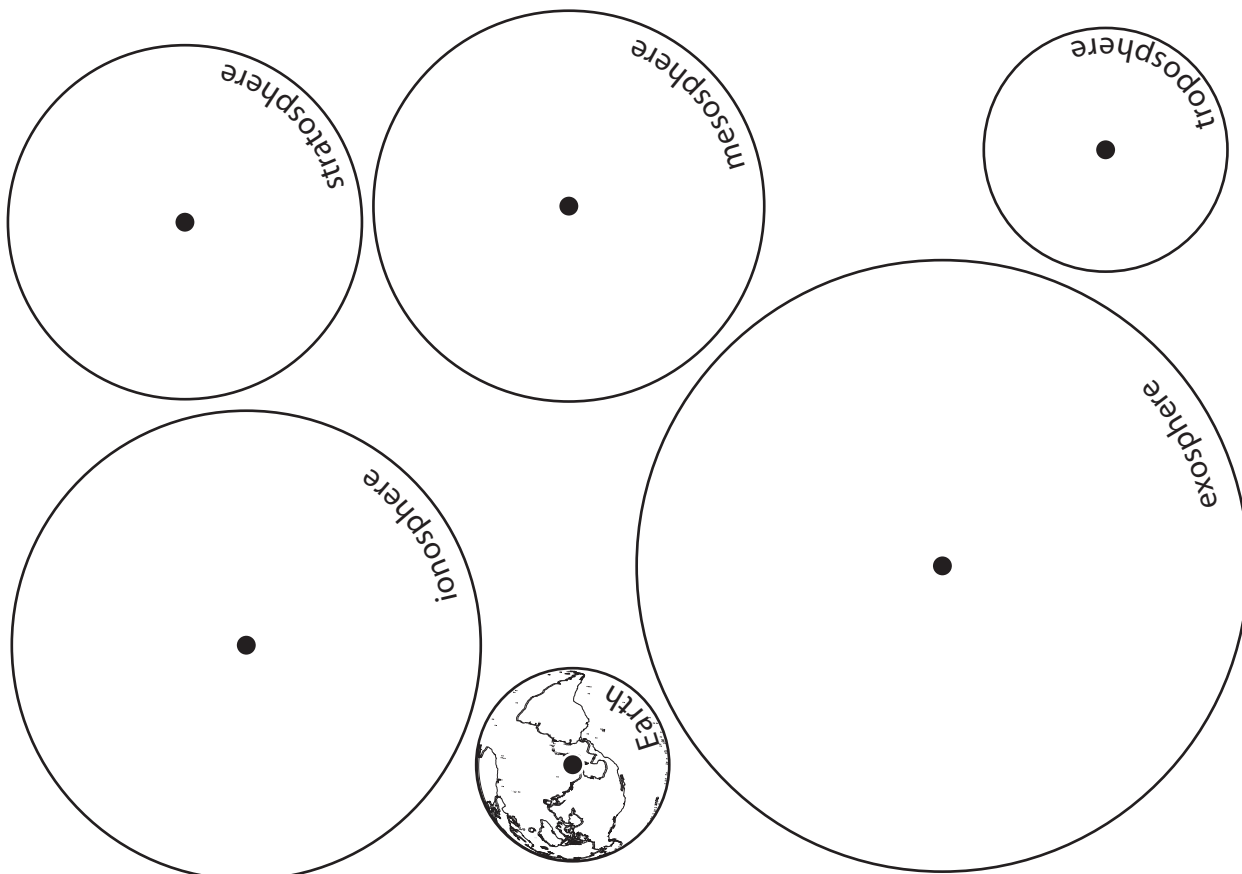

Layers of the Atmosphere

Purpose

To identify the boundaries of the different layers of the atmosphere

Procedure

1. Use internet or book resources to locate information on the layers of the atmosphere. Be sure to include each layer's boundary, location of the ozone layer, and what you might find in each layer.
2. Identify the boundary of the troposphere, stratosphere, mesosphere, thermosphere, and exosphere on the grid.
3. On the left-hand side of the grid, label each layer.
4. Use different color pencils to shade in the area of the grid represented by each layer.
5. Identify the location of the ozone layer and label.
6. Create a key for each of the following and place them in the correct atmospheric layer: aurora, airplane, ionosphere, magnetosphere, space satellites, living things, meteor, and weather.

Materials

grid sheet
pencil
colored pencils
research resources
for the layers of
the atmosphere

Research

1. In which layer of the atmosphere is the jet stream located? _____
2. How fast does the jet stream flow? _____
3. What force holds the layers of the atmosphere to the Earth? _____
4. What is the most common gas in the atmosphere? _____
5. Why is the ozone layer important? _____

6. Why is the atmosphere important? _____



Layers of the Atmosphere

Layers of the Atmosphere

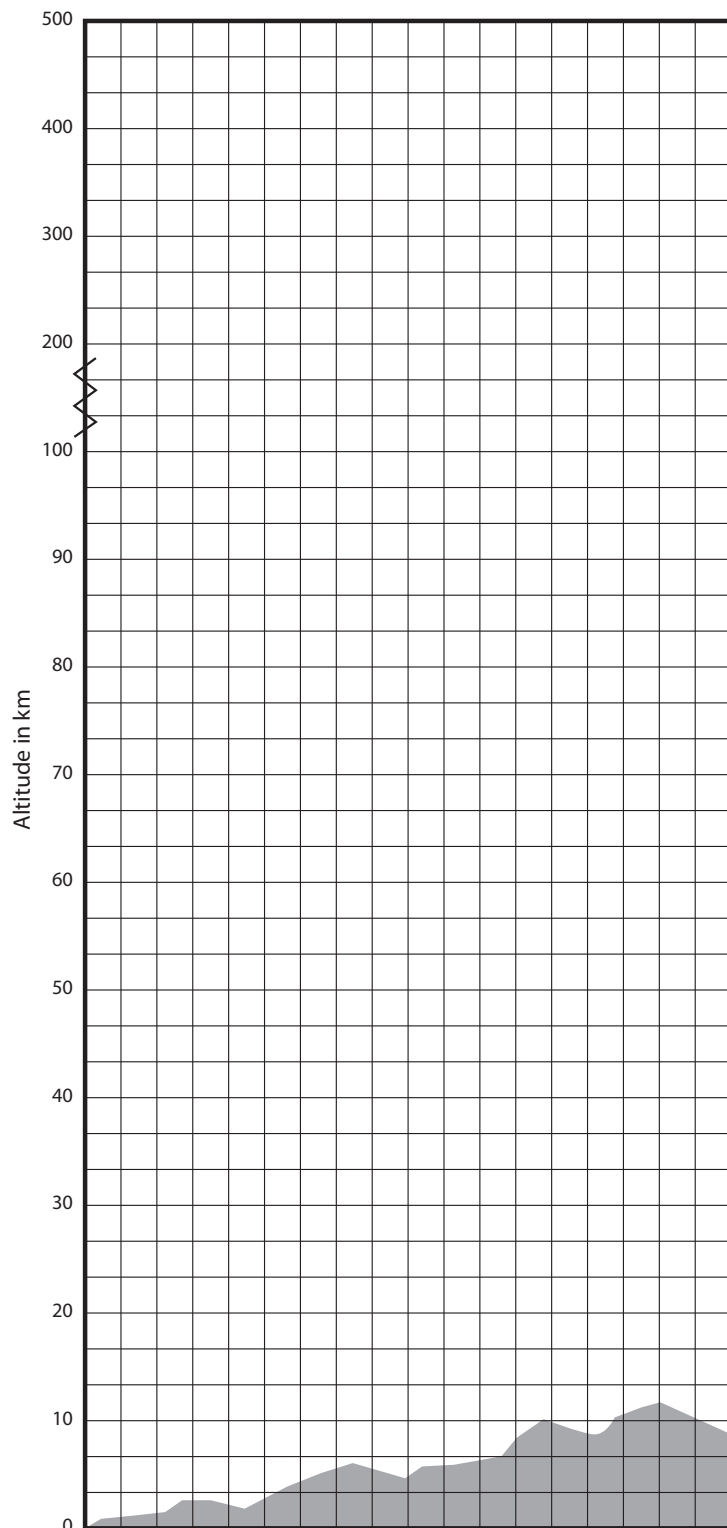

Key

-  aurora
-  airplane
-  ionosphere
-  magnetosphere
-  space satellite
-  living things
-  meteor
-  weather



Riding the Jet Stream

Watch a weather forecast on your local news channel. Observe the position of the jet stream(s) and draw the jet stream(s) on the map below using green marker or pencil.



1. How many jet streams were there? _____
2. Why does the jet stream curve and bend? _____

3. Explain how the jet stream could carry dust and ash more quickly to Virginia from the Pacific Ocean. _____

Tracking an Ash Cloud

Volcanic ash can be a serious hazard to jet airplanes when they are flying. Because pilots may not see volcanic ash clouds, they can fly into them. When ash is sucked into a jet engine, it can cause the engine to stall. Fortunately, when stalls have occurred, the pilots have been able to restart their engines, but only after losing many thousands of meters in altitude.

Procedure

You are an air traffic controller (teacher will assign you a location), and you have just received a warning that there was a major eruption of Mount St. Helens this morning. The air space you monitor is in the path of an ash cloud. Your job is to calculate approximately how many hours it will take the ash cloud to move into the air space you monitor. The warning notice states that the ash cloud is moving at a rate of 96 km/h (60 mph).

Knowing how fast the ash cloud is moving, your job is to calculate approximately how many hours (the time) it will take the ash cloud to reach your air traffic control tower.

1. On the map (Tracking an Ash Cloud), find the location of your assigned tower and circle it on the map.
2. Find Mount St. Helens and circle it on the map.
3. Look at the map legend. Calculate the number of kilometers (distance) your tower is from Mount St. Helens and record it here _____.
4. Use this formula to find how many hours (time) it will take the ash cloud to reach your tower.

$$\frac{\text{Distance (D)}}{\text{Rate (R)} \times \text{Time (T)}}$$

5. The ash cloud will reach your air traffic control tower in _____ hours.
6. A second plume of dust and ash has erupted and it is moving at 110 kilometers per hour. Calculate how many hours it will take this ash cloud to reach your tower.
7. How would the jet stream affect the time it takes for the ash cloud to reach your tower.



Tracking an Ash Cloud



Legend 0 600 km



Answer Key

How Fast Does She Blow?

1. 10
 2. 8
 3. 4
 4. 6
 5. 0
 6. 2
 7. 12
1. Vectors should graduate from short to longer.
 2. 0-2
 3. Draw the vector in the direction that the wind is blowing. If it were a northeast wind, you would point the vector NE.

Global Winds

1. The U. S. is in the Northern Hemisphere and lies within the prevailing westerlies.
2. The wind blows generally from the East to the West.
3. By learning that the prevailing westerlies blow from East to West, the tree house detectives realized that the ash and dust from Mt. Luminous would blow toward Virginia.
4. Wind helps move weather systems in the general direction of the wind pattern. Weather systems in the U.S. generally move from east to west.

As the World Turns

1. No, the line was not straight. The line curved inward because the disk was spinning.
2. The Earth is spinning, causing the wind to deflect to the right in the Northern Hemisphere. This deflection is called the Coriolis Effect. Wind in the Northern Hemisphere flows to the right as shown by the line on the disk.

Layer Upon Layer

1. troposphere
2. exosphere
3. troposphere and stratosphere

Layers of the Atmosphere

troposphere

up to 350 km per hour

gravity

nitrogen

The ozone layer protects us from harmful UV radiation.

The atmosphere is important because without it we could not sustain life. Oxygen in the atmosphere is necessary for us to breathe. The ozone layer protects us from UV rays that could cause skin cancer and even death, and the atmosphere provides us with weather that maintains the water cycle.

Tracking an Ash Cloud

7. The jet stream would be moving at a faster speed; therefore, the ash cloud would arrive much sooner.

