

# Coronagraph Backup Charts

Dr. Martin Flannery

TRW

- 
- 15 arcsec square FOV
  - System focal length = 309.7 meters
  - F-number = 11.0234
  - 6 to 45 micron RMS diameter spots
  - Diffraction-limited spot size @ 7 microns = 188 microns
  - 10 reflective surfaces
  - Four transmissive elements:
    - Occulting Spot
    - Lyot Stop
    - Spectral Filter
    - Chromatic Correcting Plate
    - If Occulting Spot is not on a transmissive substrate, the Chromatic Correcting Plate will be deleted.
  - Final imager is a three-mirror anastigmat with three aspheric surfaces.
  - Final Plate Scale = 666 milliarcsec / mm

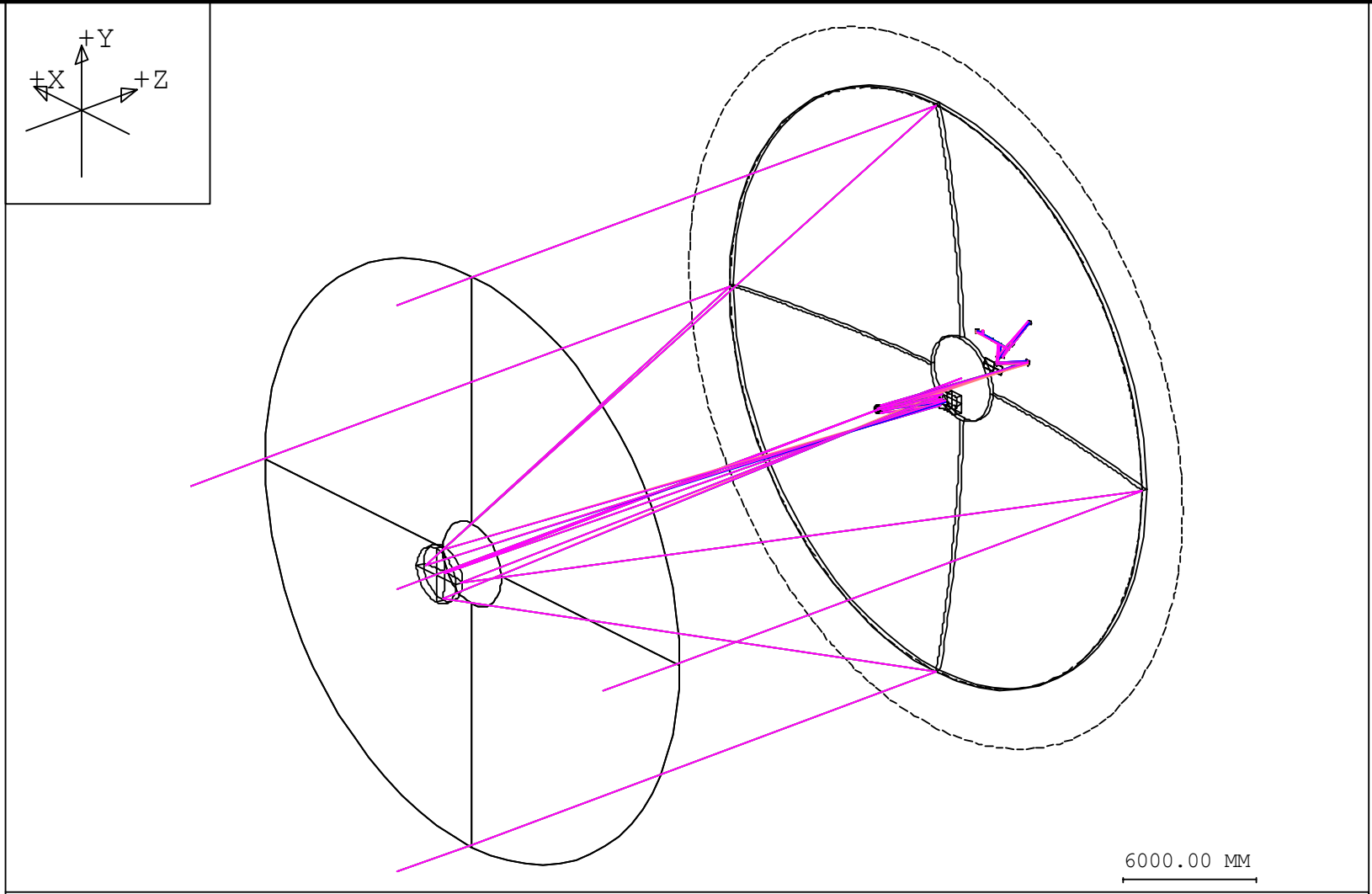

TPF: f/11, 28-m Dia, Coronagraph

MRF 09-Dec-01

# Perspective View From Telescope Field Stop to Coronagraph FP

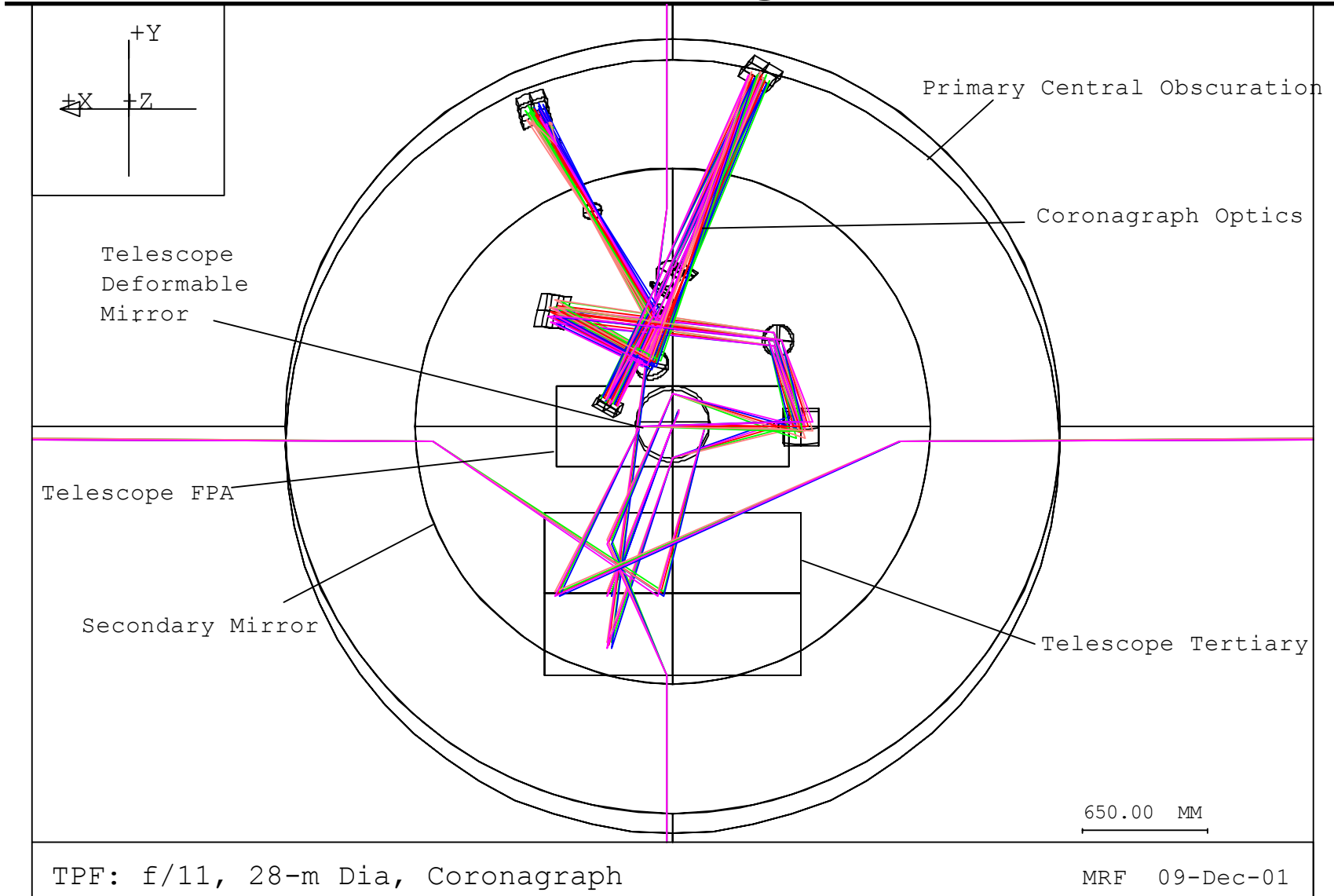

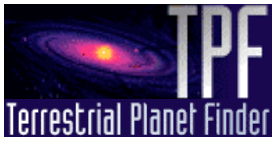

# Coronagraph Aperture Location on Telescope FP

---

TRW

Focal plane looking out through telescope

Coronagraph FOV: 15 arcsec square (41.19 mm)

Coronagraph FOV is centered at  $(X,Y) = (0.055, -0.145)$  deg.

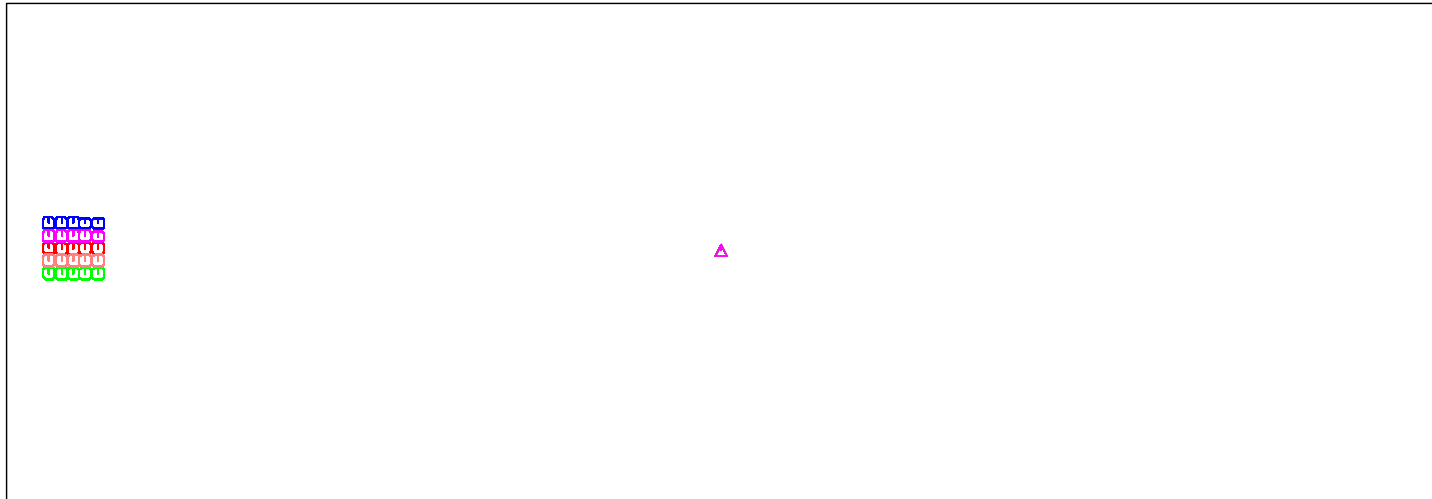

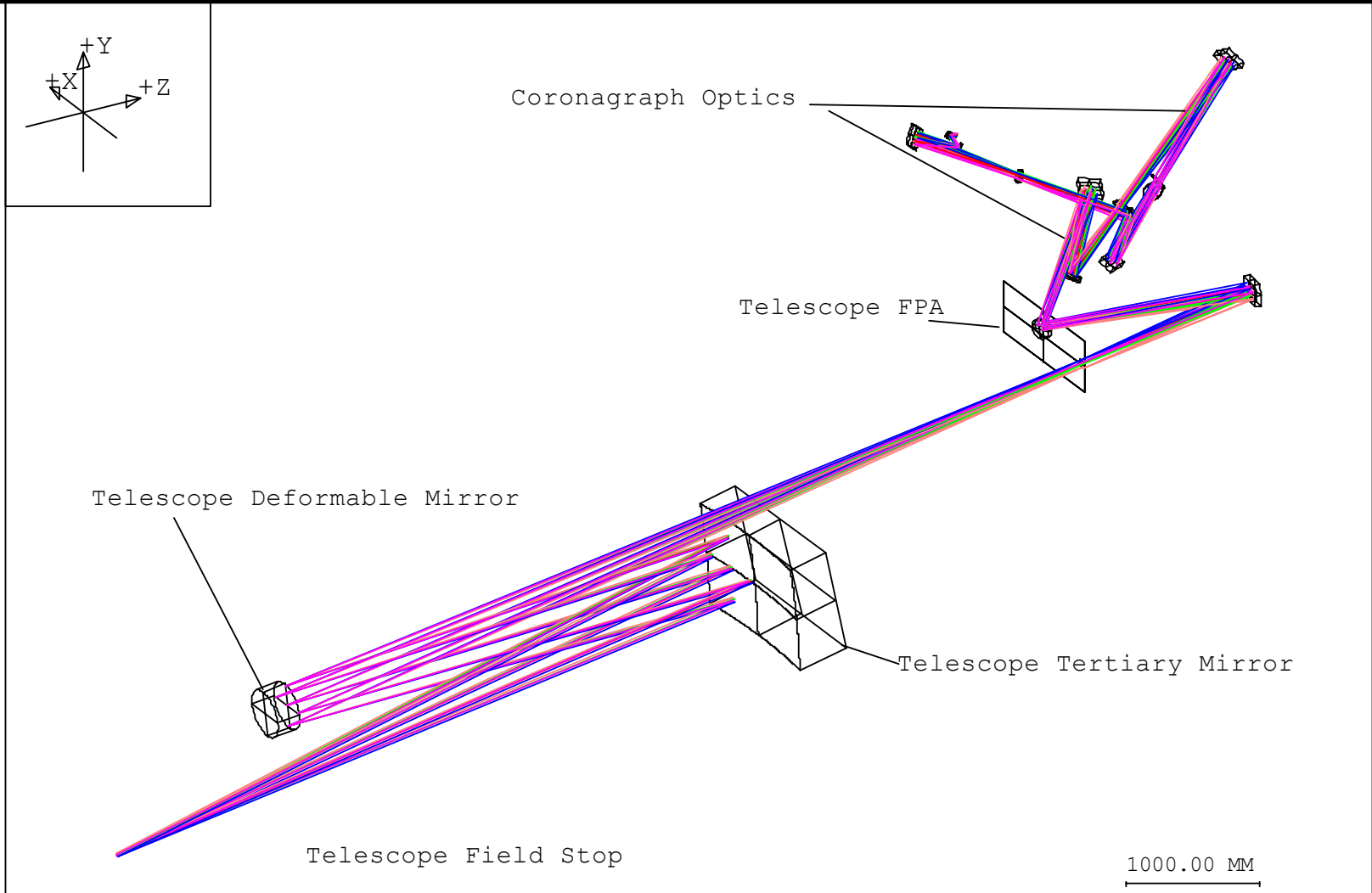

TPF: f/11, 28-m Dia, Coronagraph

MRF 09-Dec-01

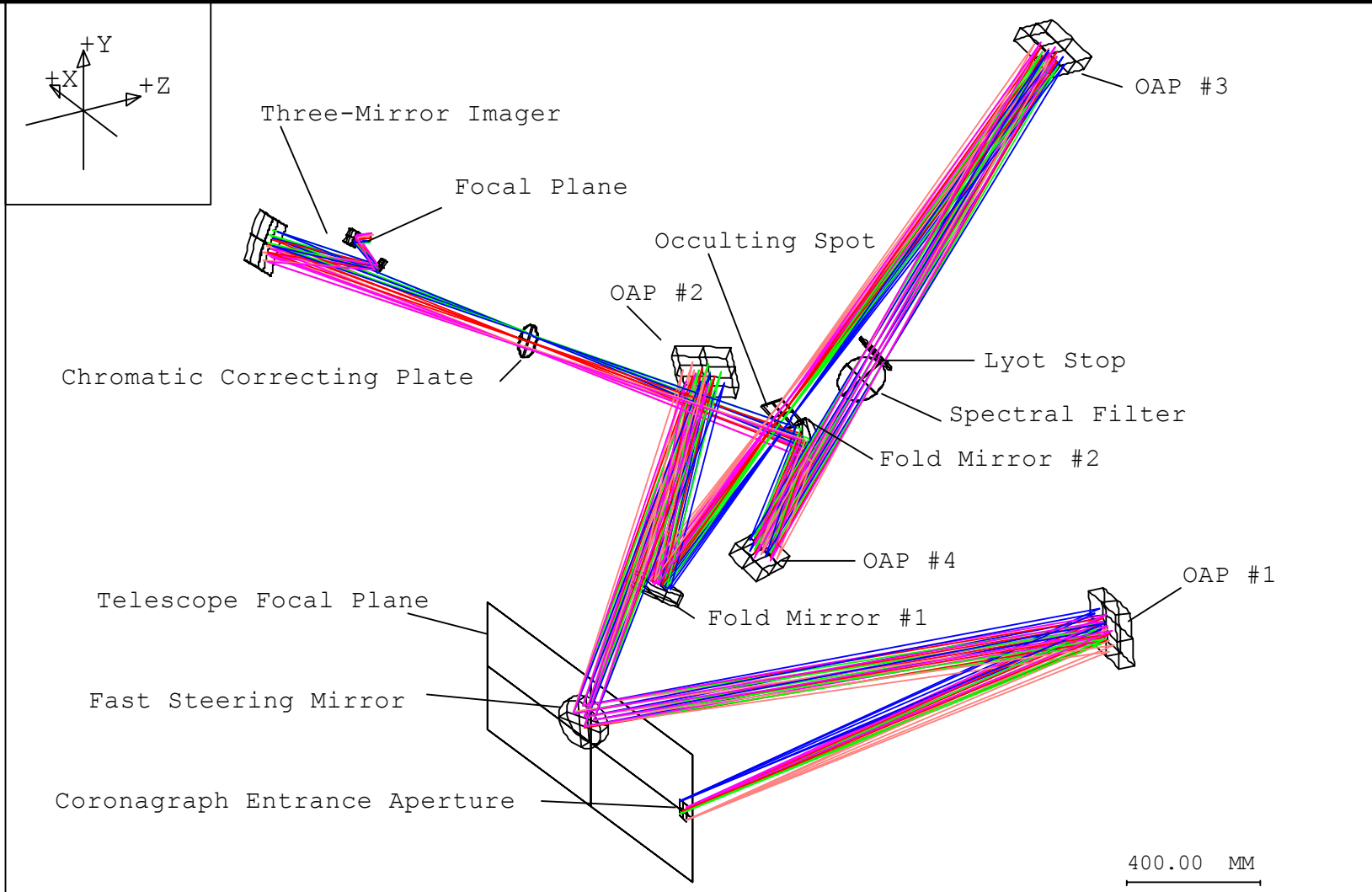

TPF: f/11, 28-m Dia, Coronagraph

MRF 09-Dec-01

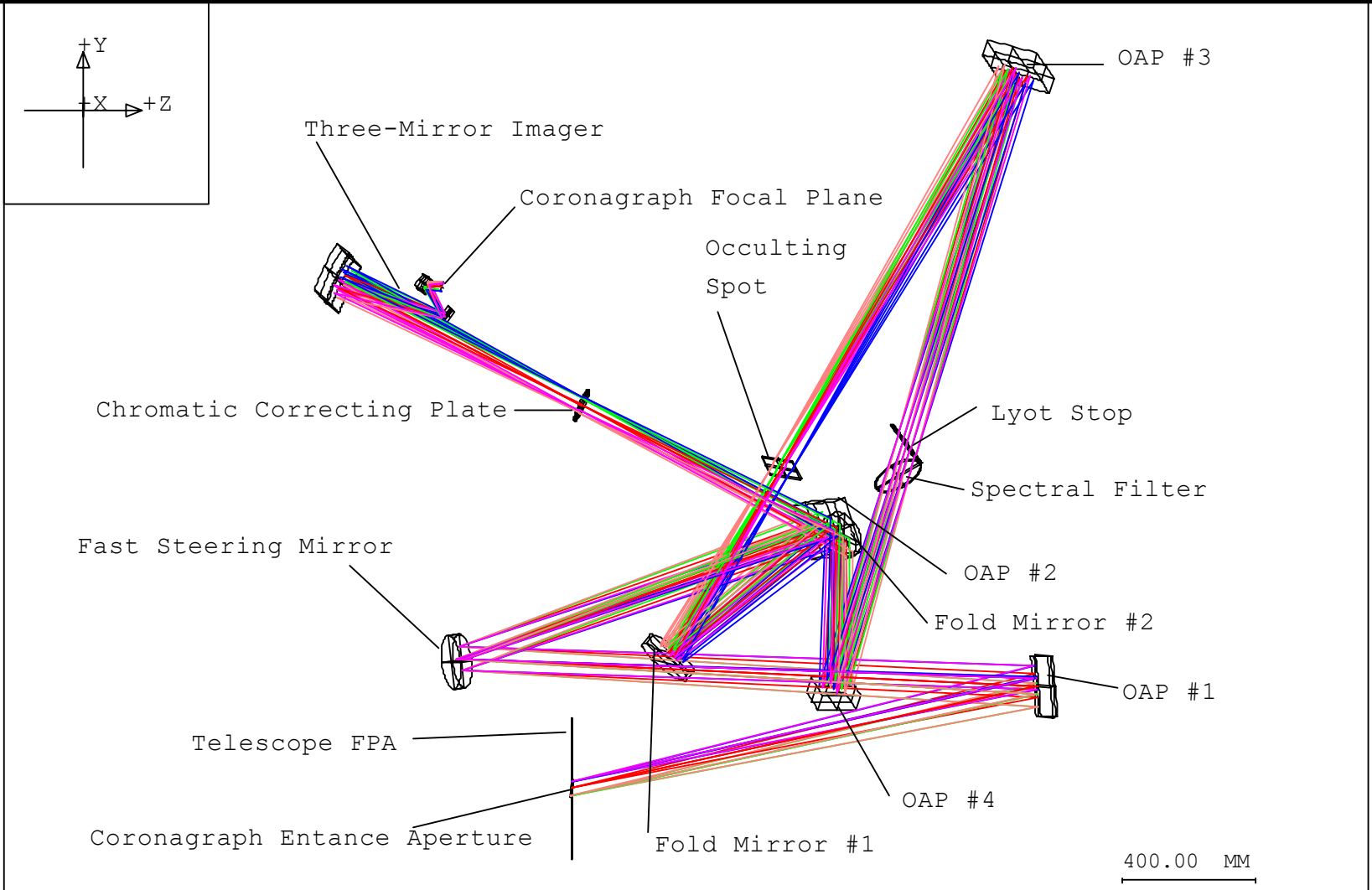

TPF: f/11, 28-m Dia, Coronagraph

MRF 09-Dec-01



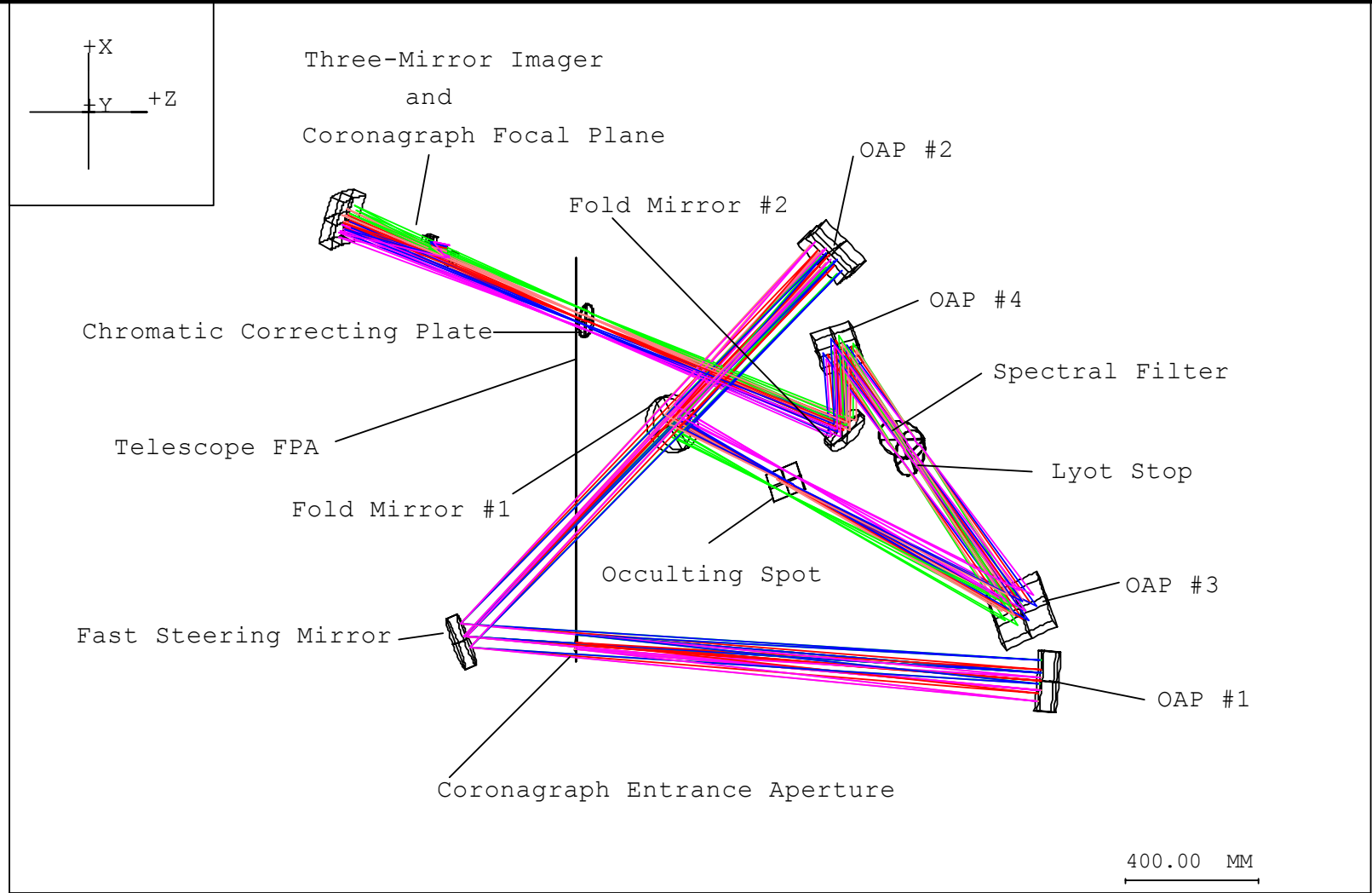

400.00 MM

TPF: f/11, 28-m Dia, Coronagraph

MRF 09-Dec-01

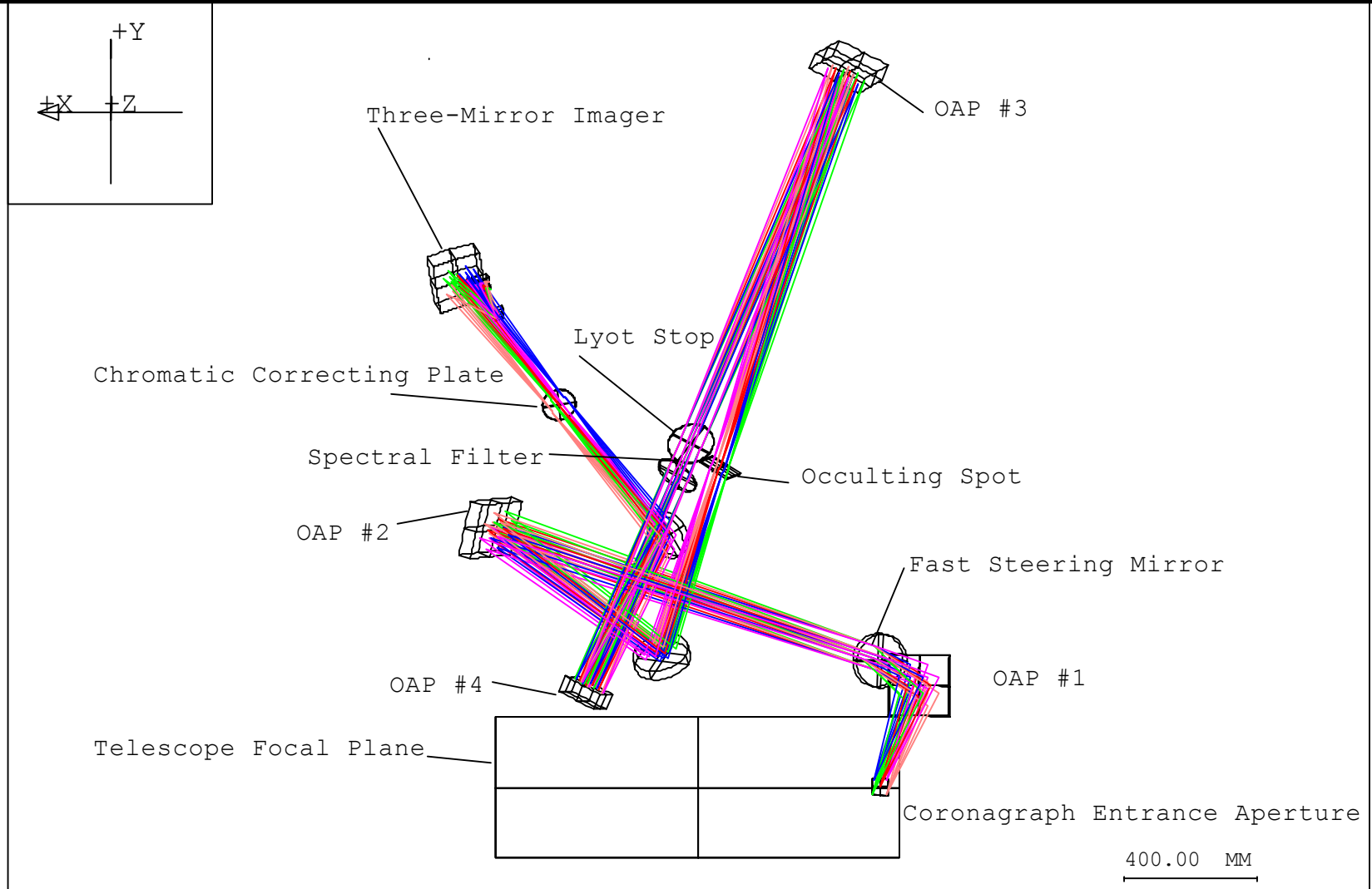

TPF: f/11, 28-m Dia, Coronagraph

MRF 09-Dec-01

