



Micro-Fabricated Solid-State Radiation Detectors for Active Personal Dosimetry

*John D. Wrbanek, Susan Y. Wrbanek, and Gustave C. Fralick
Glenn Research Center, Cleveland, Ohio*

*Liang-Yu Chen
Ohio Aerospace Institute, Brook Park, Ohio*

NASA STI Program . . . in Profile

Since its founding, NASA has been dedicated to the advancement of aeronautics and space science. The NASA Scientific and Technical Information (STI) program plays a key part in helping NASA maintain this important role.

The NASA STI Program operates under the auspices of the Agency Chief Information Officer. It collects, organizes, provides for archiving, and disseminates NASA's STI. The NASA STI program provides access to the NASA Aeronautics and Space Database and its public interface, the NASA Technical Reports Server, thus providing one of the largest collections of aeronautical and space science STI in the world. Results are published in both non-NASA channels and by NASA in the NASA STI Report Series, which includes the following report types:

- **TECHNICAL PUBLICATION.** Reports of completed research or a major significant phase of research that present the results of NASA programs and include extensive data or theoretical analysis. Includes compilations of significant scientific and technical data and information deemed to be of continuing reference value. NASA counterpart of peer-reviewed formal professional papers but has less stringent limitations on manuscript length and extent of graphic presentations.
- **TECHNICAL MEMORANDUM.** Scientific and technical findings that are preliminary or of specialized interest, e.g., quick release reports, working papers, and bibliographies that contain minimal annotation. Does not contain extensive analysis.
- **CONTRACTOR REPORT.** Scientific and technical findings by NASA-sponsored contractors and grantees.

- **CONFERENCE PUBLICATION.** Collected papers from scientific and technical conferences, symposia, seminars, or other meetings sponsored or cosponsored by NASA.
- **SPECIAL PUBLICATION.** Scientific, technical, or historical information from NASA programs, projects, and missions, often concerned with subjects having substantial public interest.
- **TECHNICAL TRANSLATION.** English-language translations of foreign scientific and technical material pertinent to NASA's mission.

Specialized services also include creating custom thesauri, building customized databases, organizing and publishing research results.

For more information about the NASA STI program, see the following:

- Access the NASA STI program home page at <http://www.sti.nasa.gov>
- E-mail your question via the Internet to help@sti.nasa.gov
- Fax your question to the NASA STI Help Desk at 301-621-0134
- Telephone the NASA STI Help Desk at 301-621-0390
- Write to:
NASA Center for AeroSpace Information (CASI)
7115 Standard Drive
Hanover, MD 21076-1320



Micro-Fabricated Solid-State Radiation Detectors for Active Personal Dosimetry

*John D. Wrbanek, Susan Y. Wrbanek, and Gustave C. Fralick
Glenn Research Center, Cleveland, Ohio*

*Liang-Yu Chen
Ohio Aerospace Institute, Brook Park, Ohio*

National Aeronautics and
Space Administration

Glenn Research Center
Cleveland, Ohio 44135

Acknowledgments

We extend our thanks to James Williams, Emye Benavage (retired), and Jim Fleet of the R&D Labs Technical Branch for their optical hardware and electronics support in this effort. We also thank Jim Mazor of Sierra Lobo Inc. for mechanical support as part of the NASA Glenn Research Center Test Facilities Operation, Maintenance, and Engineering (TFOME) organization. We are grateful to Dr. Frank Cucinotta of the Space Radiation Health Project Office and Mark Weyland of the Space Radiation Analysis Group at NASA Johnson Space Center (JSC) for their discussions on crew dosimetry. This work was accomplished with the support of the Advanced Extra-Vehicular Systems Project of NASA's Exploration Systems Mission Directorate and the LEAP and Subsonic Projects of NASA's Aeronautics Research Mission Directorate. This work was sponsored by the Life Support and Habitation Program.

This report contains preliminary findings,
subject to revision as analysis proceeds.

This work was sponsored by the Fundamental Aeronautics Program
at the NASA Glenn Research Center.

Level of Review: This material has been technically reviewed by technical management.

Available from

NASA Center for Aerospace Information
7115 Standard Drive
Hanover, MD 21076-1320

National Technical Information Service
5285 Port Royal Road
Springfield, VA 22161

Available electronically at <http://gltrs.grc.nasa.gov>

Micro-Fabricated Solid-State Radiation Detectors for Active Personal Dosimetry

John D. Wrbanek, Susan Y. Wrbanek, and Gustave C. Fralick
National Aeronautics and Space Administration
Glenn Research Center
Cleveland, Ohio 44135

Liang-Yu Chen
Ohio Aerospace Institute
Brook Park, Ohio 44142

Summary

Active radiation dosimetry is important to human health and equipment functionality for space applications outside the protective environment of a space station or vehicle. This is especially true for long duration missions to the moon, where the lack of a magnetic field offers no protection from space radiation to those on extravehicular activities. In order to improve functionality, durability and reliability of radiation dosimeters for future NASA lunar missions, single crystal silicon carbide devices and scintillating fiber detectors are currently being investigated for applications in advanced extravehicular systems. For many years, NASA Glenn Research Center has led significant efforts in silicon carbide semiconductor technology research and instrumentation research for sensor applications under extreme conditions. This report summarizes the technical progress and accomplishments toward characterization of radiation-sensing components for the recommendation of their fitness for advanced dosimetry development.

Symbols and Acronyms

α	Alpha (Particle)
γ	Gamma (Ray)
ϵ	Mean Ionization Energy (eV)
μ	Electron Drift Mobility (cm ² /V-s)
ρ	Density (g/cm ³)
ALARA	As Low As is Reasonably Achievable
cpm	Counts per minute
C-V	Capacitance-Voltage
DOE	Department of Energy
E_d	Displacement energy (eV)
E_g	Minimum Band Gap (eV)
EIT	Extreme-ultraviolet Imaging Telescope
EMU	Extravehicular Mobility Unit
EVA	Extravehicular Activity
F	Fano factor
FWHM	Full Width Half Maximum
GCR	Galactic Cosmic Radiation
GRC	Glenn Research Center
H_0	Peak bin in an energy spectrum
ICRP	International Commission on Radiological Protection
I-V	Current-Voltage

JSC	Johnson Space Center
LEO	Low Earth Orbit
LSS	Life Support Subsystem
MCA	Multichannel Analyzer
MEMS	Micro-Electro-Mechanical System
NASA	National Aeronautics and Space Administration
NCRP	National Council on Radiation Protection and Measurements
OSL	Optically Stimulated Luminescence
PMT	Photo-Multiplier Tube
Si	Silicon
SiC	Silicon Carbide
SOHO	Solar & Heliospheric Observatory
SPE	Solar Particle Event
SSA	Space Suit Assembly
TLD	Thermo-luminescent Detectors
TMG	Thermal Micrometeoroid Garment
VLPC	Visible Light Photon Counter

Introduction

The current monitoring of the impact of radiation conditions on astronauts and support equipment during Extravehicular Activity (EVA) is limited to post-mission, accumulative information provided by dosimeter badges. Improvements in the basic dosimeter design would provide a valuable tool to improve astronaut safety and provide better awareness of the external situation. This report outlines technology development at NASA Glenn Research Center (GRC) that will lead to a wearable, electronic dosimetry system which would not be adversely affected by radiation with improved sensitivity and detection capability for real-time monitoring of EVA conditions.

Radiation Environment

The primary threat to astronauts from space radiation is high-energy charged particles, such as electrons, protons, alpha and heavier ions, originating from galactic cosmic radiation (GCR), solar particle events (SPE's) and trapped radiation belts in earth orbit. There is also the added threat of secondary neutrons generated as the space radiation interacts with atmosphere, soil and structural materials (ref. 1).

For lunar exploration missions, the habitats and transfer vehicles are expected to provide shielding from standard background radiation. Unfortunately, the lunar EVA suit is not expected to afford such shielding. For EVA in low earth orbit (LEO), the nominal planned doses are on the order of 0.1 mSv (10 mrem), but actual doses can be up to 10 mSv (1000 mrem) after frequent geomagnetic storms and higher during SPE's. An 8-hour lunar EVA may see exposures over 1,000 mSv (100 rem), causing acute radiation sickness and increased risk of cancer (ref. 2).

Astronauts need to be aware of potentially hazardous conditions in their immediate area on EVA before a health and hardware risk arises. These conditions would include fluctuations of the local radiation field due to changes in the space radiation field and unknown variations in the local surface composition. Should undue exposure occur, knowledge of the dynamic intensity conditions during the exposure will allow more precise diagnostic assessment of the potential health risk to the exposed individual (ref. 3).

Dosimetry Issues

The traditional position of the radiological protection community to keep radiation exposures “as low as is reasonably achievable” (ALARA) has been instituted into established practices. These ALARA practices are based on recommendations of the International Commission on Radiological Protection (ICRP) and the National Council on Radiation Protection and Measurements (NCRP), and implemented into Department of Energy (DOE) regulations. Active dosimeters are addressed in Article 513 of the DOE Standard “Radiological Control” (DOE-STD-1098-99) for the DOE and its contractors as the guideline for compliance with Title 10 of the Code of Federal Regulations, Part 835 (10 CFR 835) on “Occupational Radiation Protection.” Specifically, the Standard states (ref. 4): “DOE encourages the use of electronic dosimeters for entry into high radiation areas or when planned doses greater than 100 mrem [1 mSv] in 1 work day are expected. An electronic dosimeter provides an early warning of elevated exposure through the use of alarm set points at specified dose rates or integrated doses.”

In light of ALARA practices, active personal dosimetry is specifically recommended for EVA (refs. 5 and 6). The current Man-Systems Integration Standards (NASA-STD-3000) calls for the active monitoring of radiation dosage during an entire mission, and includes either active or passive measurements for each crewmember on EVA (ref. 5). Currently this is satisfied using passive dosimeters consisting of Thermo-luminescent Detectors (TLD’s), Optically Stimulated Luminescence (OSL) detectors and CR-39 track-etch detectors (refs. 6 and 7).

However, the recommendation of the Radiation Dosimetry Working Group at NASA Johnson Space Center (JSC) is that even though the current passive dosimetry fulfills the requirements for crew health and safety, “a small active dosimeter should be developed to monitor individual astronaut exposures during EVA” (ref. 6). Further, the NCRP specifically recommends active electronic personal dosimeters for a measurement package for low earth orbit operations. The council goes on to recommend that “active dosimeters should be used inside and outside of the spacecraft...even carried on the astronaut’s person, including during EVA” (ref. 8).

Radiation dosimetry is critical to EVA operations and dosimetry instrumentation is a recognized technology gap and challenge for human space exploration in general (ref. 9). Advanced technology development for instrumentation and dosimetry for space radiation health applications is specifically called for by NASA (ref. 10). Present radiation environment monitoring is inadequate with the existing architecture beyond earth’s ionosphere (ref. 11). Reliance on current monitoring systems using solar observations in predicting SPE’s (such as X-Ray flare observations, as shown in figure 1) during flight or surface operations beyond earth orbit is not considered acceptable to allow time for crew members to reach shielded locations (ref. 13). Radiation exposure to humans is a critical issue for exploration missions and its monitoring is a technology development priority for advanced EVA systems (ref. 14).

For lunar surface missions, the warning of radiation events is considered a part of medical operations countermeasures architecture (ref. 15). A real-time radiation monitor for operations external of any habitat is needed for reducing this risk for human space exploration (ref. 16). Defining the radiation environment during lunar EVA is seen as a technology

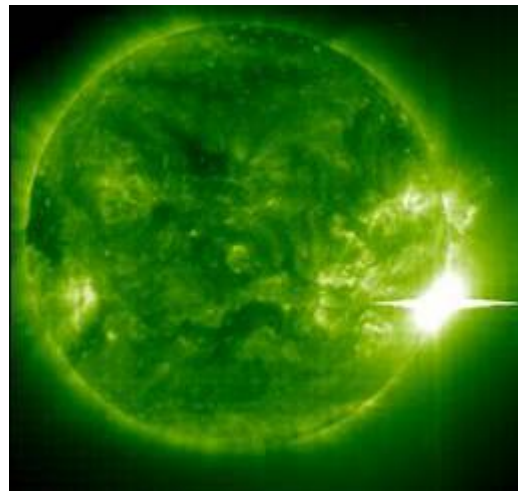

Figure 1.—The X-Ray Flare of November 4, 2004, the largest on record, as seen on the sun in the 195Å emission line by the Extreme-ultraviolet Imaging Telescope (EIT) on the Solar & Heliospheric Observatory (SOHO) (ref. 12). X-Ray Flares may be indicators of impending SPE's.

challenge that can be met by hand-held or suit mounted radiation environment sensors (ref. 11). Further, EVA suit dosimetry for astronauts is recognized as a radiation protection strategy for lunar missions (ref. 17).

Solid State Detector Technology

Astronauts need to be aware of potentially hazardous conditions in their immediate area on EVA before a health and hardware risk arises. Real-time feedback of personal dosimeter information regarding astronaut conditions is currently not available. Real-time dosimeters based on silicon electronics could provide real-time information but silicon (Si) lacks the desired sensitivity (ref. 7) and is itself affected by radiation, decreasing the effectiveness of this technology. Improvements in the basic dosimeter design would provide a valuable tool to improve astronaut safety and instrument reliability by providing better awareness of the external situation.

The utilization of a solid detection medium for radiation detection has advantages over gas ionization detectors since the densities of the medium interacting with radiation can be as high as 1000 times of that for gas detectors. Scintillators allow efficient detection of ionizing radiation over a large surface area with a fairly linear output with energy, but the low number of photoelectrons generated in a particle interaction limit energy resolution due to statistical fluctuations. Semiconductor detectors allow a greater energy resolution by generating electron-hole pairs in particle interactions similar to gas ionization detectors, but with compact sizes limited to a postage stamp or smaller (ref. 18).

Semiconductor Radiation Detectors

Micro-electro-mechanical-system (MEMS) based devices fabricated from silicon carbide (SiC) to conduct low-noise neutron and alpha particle spectrometry have been reported outside of the context of personal dosimetry (ref. 19). SiC has a wide bandgap energy and high displacement energy, so SiC sensors and electronic devices have much better resistance to radiation damage from energetic charged particles that can form electron-hole pairs in the semiconductor (ref. 20). Micro-fabricated SiC dosimeters can be small enough to be integrated into EVA pressure suits or other surfaces which need to be monitored for radiation dosages at multiple points.

As a charge particle passes through a semiconductor, many electron-hole pairs are produced as the particle loses energy. The amount of energy required to create one electron-hole pair is the ionization energy (ϵ) of the semiconductor. The ionization energies for semiconductors are typically on the order of electron volts (eV), where for gas ionization detectors are tens of electron volts. The number of electron-hole pairs is simply the energy lost (E) divided by the ionization energy. As in gas ionization detectors, the fluctuation of counting electron-hole pairs is smaller than would be expected for pure Poisson statistics, so the variance is adjusted by the Fano factor (F), which then is a direct indication of the energy resolution of the detector. Also, thermal noise of the detector is based on the rate of electron-hole pairs generated due to the band gap of the semiconductor (E_g). The electron drift mobility (μ) will affect the diffusion of electrons in the semiconductor, also a significant indicator of the noise of the detector (ref. 18). The density (ρ) of the semiconductor will affect the interaction of radiation with the semiconductor, in both the production of electron-hole pairs as well as radiation damage. The displacement energy (E_d) is an indication of sensitivity to semiconductor damage from incoming radiation. These values are given in table 1 for several semiconductors considered for radiation detector applications (refs. 21 and 22). In particular, SiC, gallium nitride (GaN), and diamond are considered to be very rad-hard materials due to their larger displacement energy, and appear to have improved energy resolution over Si from their low Fano factors. The low drift mobility of SiC suggests that this semiconductor has the lowest noise of the wide band-gap semiconductors for radiation detection.

TABLE 1.—PROPERTIES OF SEMICONDUCTORS FOR USE AS RADIATION DETECTORS (REFS. 21 AND 22)

Property	Silicon	Germanium	Gallium arsenide	Silicon carbide (SiC)	Gallium nitride (GaN)	Diamond
Minimum band gap (E_g) [eV]	1.12	0.68	1.42	2.9	3.39	5.48
Electron drift mobility (μ) [$\text{cm}^2/\text{V}\cdot\text{s}$]	1450	3900	8500	400	1000	1800
Mean ionization energy (ϵ) [eV]	3.63	2.96	4.13	6.88	8.9	12.4
Fano factor (F)	0.115	0.13	0.10	0.09	-----	0.08
Density (ρ) [g/cm^3]	2.329	5.323	5.317	3.22	6.15	3.515
Atomic mass [g/mole]	28.1	72.6	144.6	40.1	83.7	12.0
Molar density [moles/ cm^3]	0.0829	0.0733	0.0368	0.0803	0.0735	0.293
Displacement energy (E_d) [eV]	~19	-----	10	28	24	43

Scintillating Fiber Detectors

Common detectors used in spacecraft instrumentation and in accelerator particle physics experiments are scintillating fiber detectors (refs. 23 and 24). The fibers afford flexibility for conforming to novel surfaces and are able to cover surfaces of relatively large volumes. Also, the detectors are typically used in fast triggers to enable particle identification. Such detectors have been used in experiments without failure for many years at a time. The flexibility of a fiber-based dosimeter is an attractive option to allow embedded multidirectional radiation characterization of EVA pressure suits.

The scintillating fibers are organic scintillators, which have the benefit of not needing regular crystalline lattices to form electron-hole pairs as inorganic scintillators require for fluorescence. This benefit allows them to be used as a polycrystalline solid, liquid, vapor or as part of a multicomponent material. The base component of organic scintillators is typically polystyrene or polyvinyltoluene which acts as the primary absorber of radiation. Energy is transferred via a fast (<1 ns) nonradiative dipole-dipole interaction to a fluorescent dye that makes up about 1 percent of the weight of the scintillator. A third dye (called a wave shifter) may be added to absorb and re-emit the light at wavelengths that allow propagation over long distances where optical transmission is an issue. Such two component materials are referred to as binary scintillators and three component materials as ternary scintillators. The fiber themselves are typically between 0.5 and 1 mm diameter total, with a 25 μm thick cladding of acrylic around the scintillating core. Good optical performance using multicladding of multiple layers of acrylic of different index of refraction has been reported. Success using other fibers made of glass and capillaries containing scintillating liquids have been reported (ref. 23).

In use, the fibers are typically mounted side-by-side as a ribbon, either in single or double layer. The fibers are optically coupled to a waveguide block or fiber ribbon (with or without a wave shifter) for readout by a photomultiplier tube (PMT) or a visible light photon counter (VLPC). Current research is ongoing in improving the optical transmission of the scintillators, waveguides and the optical coupling of the components, as well as the development of room-temperature VLPCs for fast photon counting.

Technology Development at GRC

Technology development is ongoing at NASA GRC to meet the active dosimetry challenge. We are leveraging our efforts in radiation detection to investigate small and large area scintillating and MEMS devices for sensitivity to radiation and to compare with commercial devices. If these initial results look promising as a path for the design and fabrication of a prototype solid state dosimeter, further testing

would be required in conjunction with other researchers in the space radiation field over the next few years. The long term objective of this effort is to provide a compact, low power active electronic dosimetry system that would not be adversely affected by radiation, with improved sensitivity and detection capability for real-time monitoring of lunar EVA conditions.

Micro-Fabricated Wide Bandgap Detector Development

NASA GRC has been leading the world in the development of SiC semiconductor sensors and microelectronics. One recently developed technology is in producing SiC semiconductor surfaces of much higher quality than commercially available. These surfaces have demonstrated advantages over current commercial materials for other sensor applications (ref. 25).

The immediate goal of this technology development effort was to assemble a testing station to test and compare resolution of and sensitivity to energy deposited by alpha (α) particles into Si and SiC diode detectors. The detectors were required to be packaged in a way to allow them to be tested in the station. The electronic properties of the diodes were characterized to allow an understanding of the charge collection capability as detectors. The testing station was designed to allow a range of energies to be tested by varying the distance of the detectors from the α particle source in air using optical mountings. The results of the investigation will dictate future efforts to design and fabricate a personal active dosimeter concept for EVA systems.

Initial detector packaging

Six diodes were initially prepared for testing as radiation detectors. The first three (named D1, D2, and D3) were unpackaged SiC Schottky power diodes acquired from Cree, Inc. (Durham, North Carolina). These diodes have respectively a 10 A maximum forward current and 600 V reverse breakdown voltage, 10 A, 1200 V, 6 A, and 600 V. Two unpackaged SiC UV photo sensors (D4 and D5) were also acquired from Cree for radiation detection testing. The sixth diode (D6) was a Hamamastu S3590-02 window-less Si PIN photodiode optimized for radiation detection.

The diodes were originally attached to a ceramic printed circuit board using conductive epoxy. These diodes were electrically interconnected to the printed circuit board with gold wires using thermal sonic wirebonding. Figure 2 shows the five SiC diodes mounted on the circuit board, and figure 3 gives a schematic of the connections of the diodes.

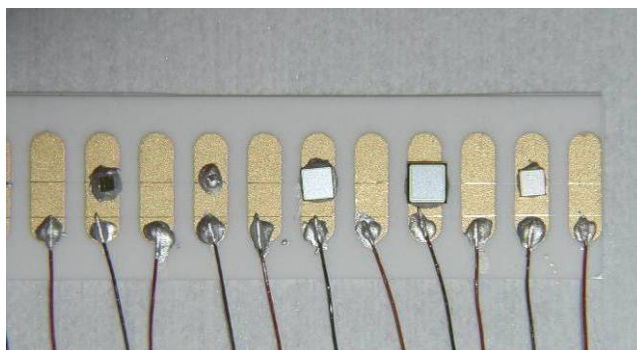

Figure 2.—Picture of the circuit board on which SiC diodes for radiation tests are mounted.

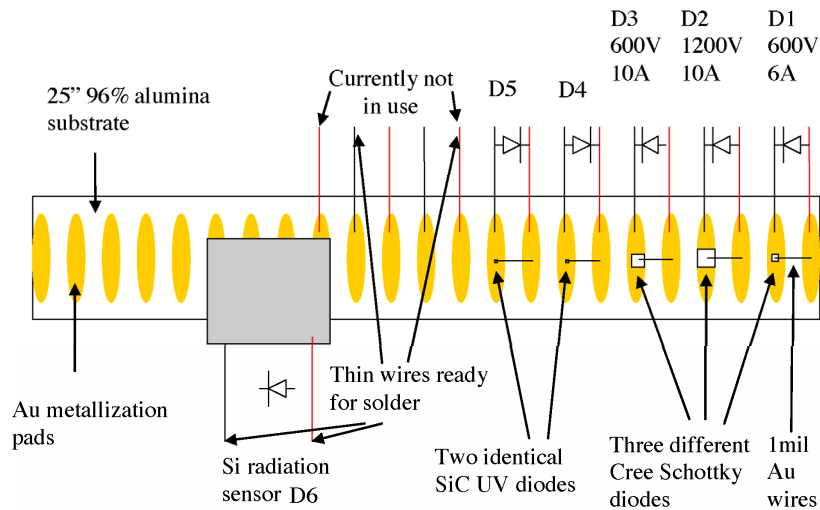

Figure 3.—Schematic of the circuit board on which all diodes were mounted.

Detector characterization

The diodes were first characterized electrically to determine the parameters to be used for radiation response testing. These basic characterizations in dark conditions include current-voltage (I-V) under both forward and reverse bias, and capacitance-voltage (C-V) under reverse (and zero) bias. Examples of the I-V and C-V data curves for these diodes are shown in figures 4 and 5. The I-V characterizations provide information about the leakage current of the devices under high voltage bias, and the C-V characterizations determine the configuration of the preamplifier for optimized charge sensing. A summary of the characteristics at various biasing voltages is shown in table 2.

TABLE 2.—I-V AND C-V CHARACTERISTICS FOR DIODE DETECTORS

Detector	D1	D2	D3	D4	D5	D6
Detector active area	3.17 mm ²	6.25 mm ²	4.0 mm ²	0.45 mm ²	0.83 mm ²	100 mm ²
Current at 0 V bias	5.55 pA	1.28 pA	-0.21 pA	-0.81 pA	0.70 pA	-2.61 nA
Current at -5 V bias	-5.38 pA	-5.20 pA	-9.07 pA	-18.7 mA	-17.8 mA	-2.78 nA
Current at -20 V bias	-11.4 pA	-9.69 pA	-14.4 pA	-----	-----	-3.22 nA
Capacitance at 0 V bias	0.400 nF	0.833 nF	0.629 nF	0.0109 nF	0.0108 nF	0.532 nF
Capacitance at -5 V bias	0.188 nF	0.408 nF	0.295 nF	0.0073 nF	0.0075 nF	0.116 nF
Capacitance at -20 V bias	0.107 nF	0.230 nF	0.167 nF	0.0051 nF	0.0055 nF	0.0724 nF

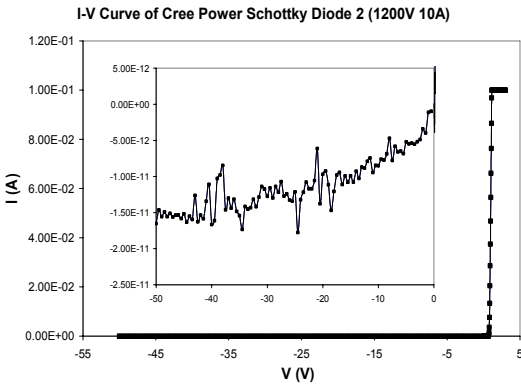

Figure 4.—Example of I-V data curve of the diodes used in radiation testing.

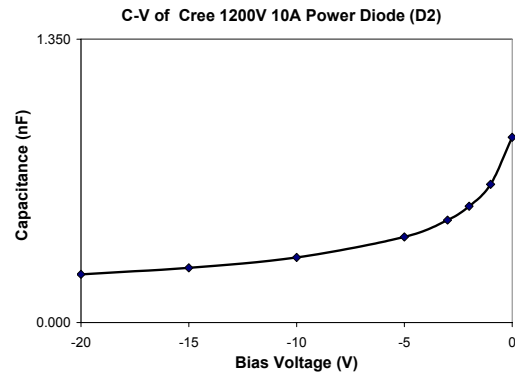

Figure 5.—Example of C-V data curve of the diodes used in radiation testing.

Testing station assembly

The testing station consists of an optical mount with three degrees of freedom and a charge preamplifier in a dark box, with bulkhead unions in the box rear to allow coaxial cable connections to processing electronics and biasing sources, as shown in figures 6 and 7. The optical mount holds the detectors and a charge sensitive preamplifier at a fixed position from the sources. This position can be adjusted to allow a variety of energies to be examined. As the charged particle loses energy in the detectors, a charge pulse is generated that is converted to a voltage pulse by the charge sensitive preamplifier. This voltage pulse height is proportional to the charge collected by the preamplifier, and thus proportional to the energy lost by the particle in the detector. The output signal from the preamplifier is connected to the digital pulse processor through the BNC connectors on the wall of the box. The digital pulse processor converts the pulses to a digital signal, and shapes the pulses for analysis in a multichannel analyzer (MCA). The MCA assigns a “bin” to each pulse that is directly proportional to the voltage height of the pulse input into the digital pulse processor. Therefore, the bin assignment of a pulse is directly proportional to the energy deposited in the detector. The digital pulse processor is directly connected with the computer for data collection and analysis. An attenuator is placed between the preamplifier and the digital pulse processor to reduce the output of the Si detector to voltage levels that can be managed by the processor. The attenuator was not necessary for the SiC detectors. The pulses could be observed with an oscilloscope at various points of the signal processing for troubleshooting. A schematic is shown in figure 8.

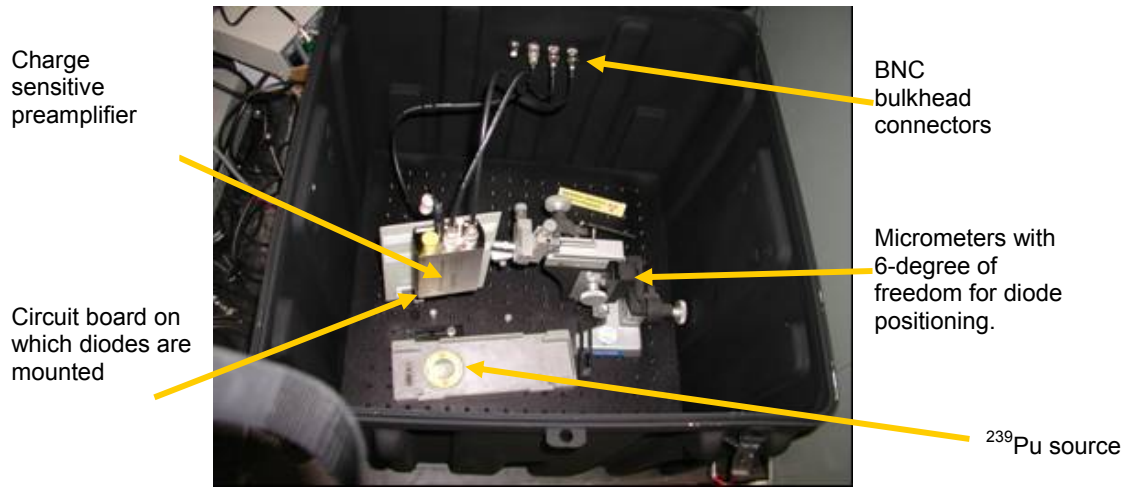

Figure 6.—Testing fixture with ^{239}Pu source.



Figure 7.—Experimental testing apparatus.

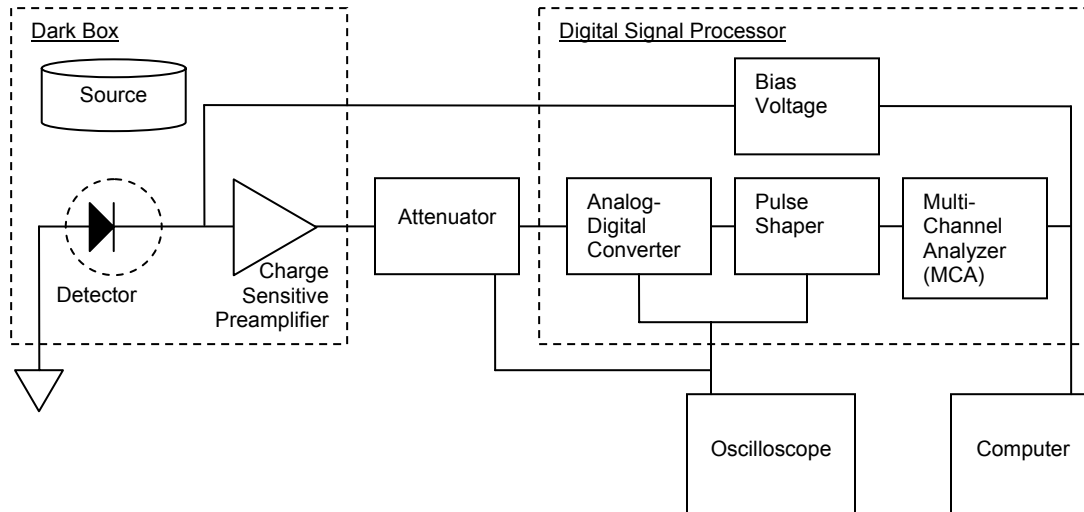

Figure 8.—Schematic of detector signal processing.

For this effort, four sources of ^{239}Pu with α particle activities of 1.05×10^3 counts per minute (cpm), 1.16×10^4 cpm, 1.16×10^5 cpm, and 1.22×10^6 cpm and one source of ^{241}Am with an activity of 0.2 microcurie (7.4 kBq or 4.44×10^5 cpm) were acquired from the NASA GRC Radiation Safety Office. The circular areas of the ^{239}Pu sources are 615 mm² and the ^{241}Am source 3 mm², and all count rates were reported over a solid angle of 2π sr. The ^{239}Pu sources emit α particles of 5.155 MeV (73.3 percent), 5.143 MeV (15.1 percent) and 5.105 MeV (11.5 percent) and γ rays of 51.6 keV with a half-life of 24,000 years (ref. 18). The ^{241}Am source emits α particles of 5.486 MeV (85.2 percent) and 5.443 MeV (12.8 percent) and gamma (γ) rays of 59.5 keV with a half-life of 433 years (ref. 18). The safety permit for using and storing these radioactive materials in the testing lab was submitted and approved to use these sources for detector testing.

Initial testing

The Si detector D6 was first tested for reaction to α particles with 0 V bias at 13, 25, and 34 mm distances using the 1.22×10^6 cpm ^{239}Pu source to allow the best statistics. Also, the energy spectrum for α particles in air at these distances and 1 mm were modeled using TRIM calculations (ref. 26), and the peaks are shown in figure 9, and summarized in table 3. The pulse height spectrum from D6 exposed to the ^{239}Pu source is shown in figure 10. The resulting distribution was disappointing as the noise levels were 30 percent of the full scale. Only the 2.2 and 3.8 MeV peaks were visible, and had widths approximately equivalent to the noise level. The noise of the system also prevented any peaks from being detected with the SiC detectors D1, D2, D3, D4, and D5.

TABLE 3.—SUMMARY OF TRIM PREDICTIONS OF ENERGY PEAKS AND WIDTHS OF α PARTICLES FROM ^{239}Pu AT VARIOUS DISTANCES IN AIR

Distance in air (mm)	Peak energy (MeV)	FWHM energy (MeV)
1	5.05	0.02
13	3.81	0.08
25	2.22	0.13
35	0.17	0.13

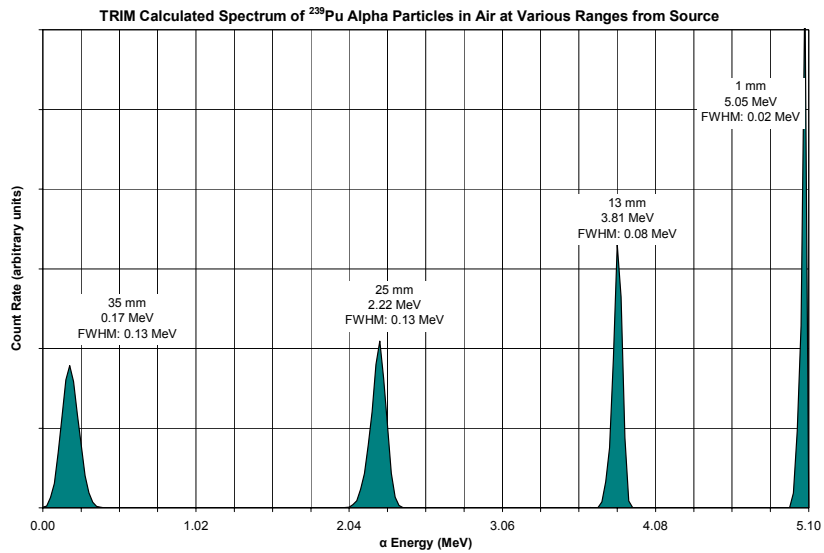

Figure 9.—TRIM Predictions of the Energy Distribution of 5.14 MeV α particles from ^{239}Pu at various distances in air.

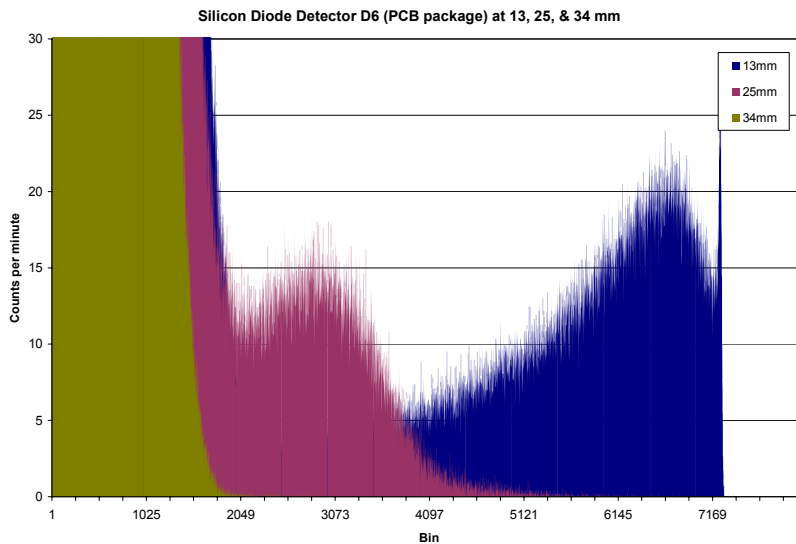

Figure 10.—Response of D6 Si PIN diode to 5 MeV α particles at different distances from the source.

Detector package redesign

To reduce electronic noise from the detectors, the packaging of the diodes was redesigned to have a shielded outside housing with a coaxial connection instead of the wires to screw terminal connections. The duplicate diodes for D1, D2, D3, and D6 were mounted with conductive epoxy on BNC connectors as shown in figure 11. The epoxy formed a 0.8 mm^2 spot for the wire connection on the surface of D1, D2, and D3, which reduced the active area of the detector. The epoxy spot size also excluded the mounting of D4 and D5 with this method. The new packaged detectors are referred to as D1b, D2b, D3b, and D6b.

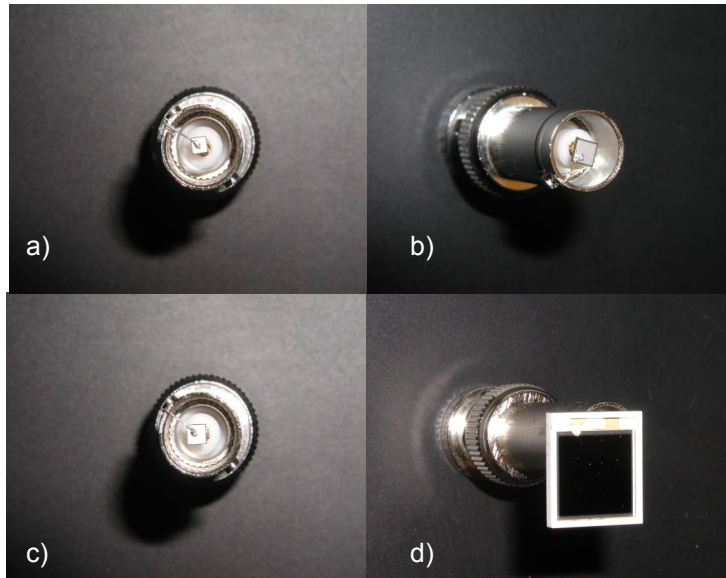

Figure 11.—Detector Package redesign for
a) D1b, b) D2b, c) D3b, and d) D6b.

The SiC detector D2b and the Si detector D6b, the two largest area detectors of the lot, were tested for response to α particles with 0 V bias, -4 V bias, and -20 V bias at a fixed 1 mm distance from the 1.22×10^6 cpm ^{239}Pu source. Again, the high cpm source was chosen to obtain the best statistics. The close proximity of the detectors to the sources compared to the large area of the source removes the need for solid angle corrections. The resulting energy spectra are given in figure 12 for D2b and figure 13 for D6b. Future tests will include D1b and D3b as warranted.

A summary of the characteristics of the detectors is given in table 4. The peak bin (H_0) was found using an average of the product of the cpm with the bin number, and then dividing by the average cpm for the range. The bin range was selected around the visible peak structure, which varied from 400 to 1200 bins depending on the data set. Once H_0 was located, the peak cpm was found by averaging the counts of 40 bins on either side of the peak bin. The half maximum of the peak cpm was used to determine the noise floor and the full width half maximum (FWHM) values. The resolution of the system is determined by dividing the FWHM by H_0 (ref. 18). The integrated cpm was determined by summing the cpm of the bins at FWHM from either side of the peak, such that the total width of the bins summed was twice FWHM.

From the data in table 4, the Si detector had a higher noise floor than the SiC detector, and also the Si detector had the high signal output. The signal-to-noise ratio is on average over a factor of two greater for

TABLE 4.—SUMMARY OF DATA ON BNC PACKAGED DETECTORS

Detector	2b	2b	2b	6b	6b	6b
Bias	0	-4 V	-20 V	0	-4 V	-20 V
5 MeV peak bin	4087	5201	6396	18910	24268	25384
5 MeV peak cpm	4.75	8.40	7.41	199	212	213
Noise floor bin (1/2 peak cpm)	814	491	328	1464	932	644
Signal to noise	5.0	10.6	19.5	12.9	26.0	39.4
FWHM (bins)	658	810	852	1952	3312	3400
Resolution	16%	16%	13%	10%	14%	13%
5 MeV integrated cpm (99%)	3518	7534	6847	95093	171166	173988
5 MeV cpm/mm ²	646	1382	1256	951	1712	1740

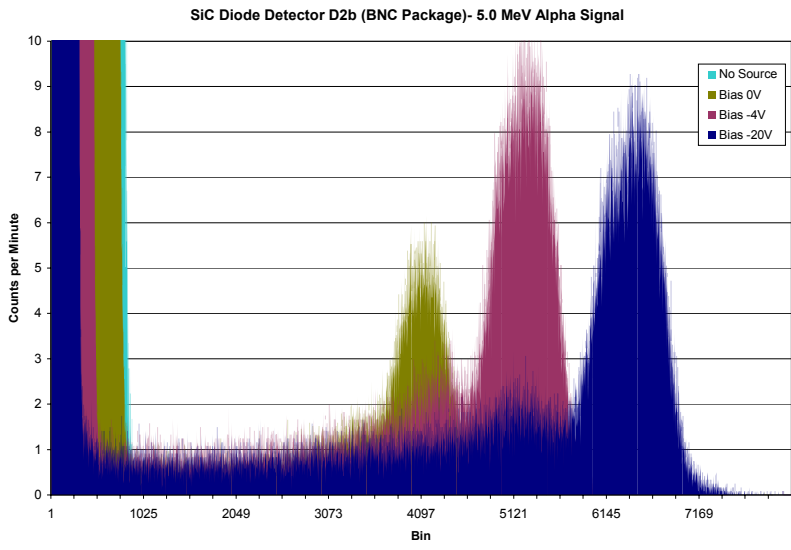

Figure 12.—Response of D2b SiC Schottky diode to 5 MeV α particles at different bias voltages.

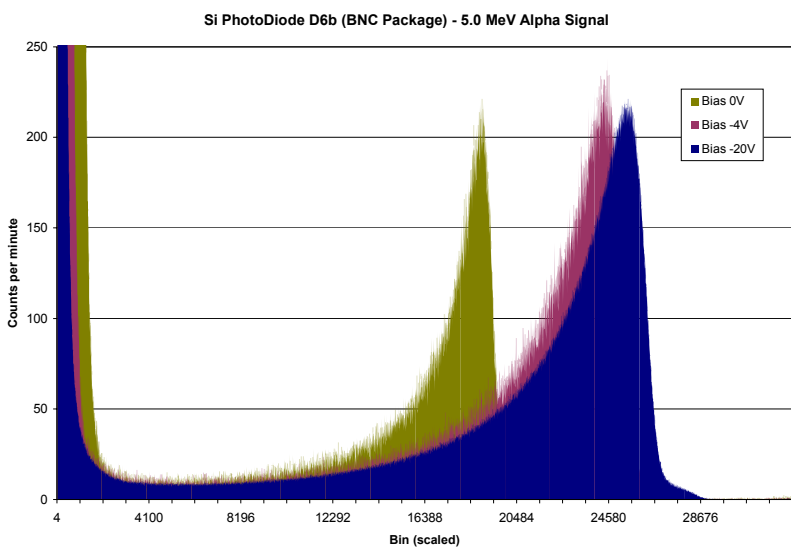

Figure 13.—Response of D6b Si PIN diode to 5 MeV α particles at different bias voltages.

the silicon detector than the SiC detector. However, the resolutions of the two detectors are the same to ± 2.3 percent, which can be reasonably attributed to statistical variation, and may be more of a reflection of the signal processing. The integrated cpm for the Si diode is larger due to the larger area, and the integrated cpm per area is also greater with the Si diode may be due to the fact that D6b was a PIN diode optimized for radiation detection, and D2b is a non-optimized Schottky diode. The energy spectrum using the Si detector in figure 13 also shows a “tail” from losses due to the electrons diffusing through the semiconductor which was not seen in the SiC detector in figure 12. As can be seen in table 1, SiC has lower electron diffusion than Si to which the lack of tails can be attributed.

Thin Film Coated Scintillating Detectors

In other activities, NASA GRC is attempting to verify claims (refs. 27 to 30) of nuclear energy in sonoluminescence (shown in fig. 14) using a thin film coated scintillation detector fabricated at NASA GRC (ref. 31). The detector consists of a coated scintillator connected to a photomultiplier tube (PMT) module with fiber optics. The scintillator generates a pulse of light when interacting with an ionizing particle. The coating is selected to function as either an attenuator or a convertor to allow radiation to react with the scintillator, and also to prevent the sonoluminescence light from generating false readings. The detection of reaction products will allow verification of power generation in sonoluminescence. Figure 15 shows a prototype detector that has been tested using background radiation. The concept of utilizing fiber optic detectors for limited volume spaces could be applied to EVA suits.

Fiber optic dosimeter concept

The current Extravehicular Mobility Unit (EMU) has three major assemblies: The Space Suit Assembly (SSA), the Life Support Subsystem (LSS), and EMU ancillary equipment. An example EMU from STS114 is shown in figure 16. The SSA is the pressure vessel that encloses the astronaut’s torso, limbs, and head. The components of the SSA are covered with Thermal Micrometeoroid Garments (TMG’s) consisting of an outer reflecting layer of puncture- and fire-resistant white “Ortho-Fabric” consisting of a blend of fluoropolymer and aromatic polyamide fabrics, five insulating layers of aluminized reinforced polyester film, and an inner lining of polychloroprene-coated nylon ripstop fabric. The purpose of the TMG’s is to provide environmental protection during the course of an EVA (ref. 32). As part of the environmental protection, the insertion of a flexible optical fiber ribbon radiation detection system may be included in the design of a future EMU SSA. An image of this concept is shown in figure 17 with a 12 mm wide, 1 mm thick single layer fiber ribbon and a sample of TMG.



Figure 14.—Sonoluminescence created at NASA GRC (true color, contrast enhanced).

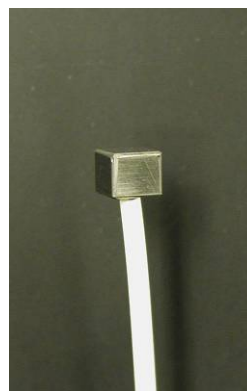

Figure 15.—Fiber optic radiation detector prototype.



Figure 16.—The EMU as used on STS-114.

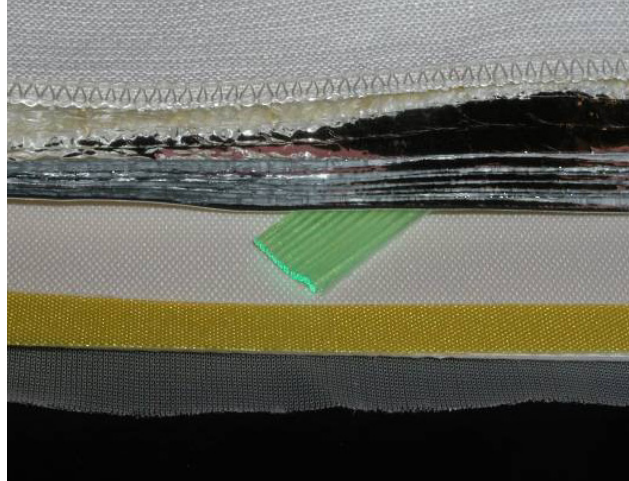

Figure 17.—A concept of a 12 mm wide fiber optic ribbon dosimeter between sample TMG and pressure suit layers for an EMU.

Conclusions and Future Plans

Current monitoring of radiation conditions during LEO EVA is limited to post-mission, accumulative information provided by passive dosimeter badges. Improvements in the basic dosimeter design would provide a valuable tool to improve astronaut safety and equipment reliability, providing better awareness of the external situation. The utilization of a solid detection medium for radiation detection has advantages over gas ionization detectors since the densities of the medium interacting with radiation can be as high as 1000 times of that for gas detectors. Scintillators allow efficient detection of ionizing radiation over a large surface area with a fairly linear output with energy, but the low number of photoelectrons generated in a particle interaction limit energy resolution due to statistical fluctuations. Semiconductor detectors allow a greater energy resolution by generating electron-hole pairs in particle interactions similar to gas ionization detectors, but with compact sizes limited to a postage stamp or smaller. Another trade-off in detector selection is that the power for semiconductor detectors needs to be provided at the sensing location, whereas the power for scintillator detectors does not need to be at the sensing location through the use of optical fibers.

Technology development is ongoing at NASA GRC to meet the active dosimetry challenge. An experimental testing system including both hardware and software for radiation sensitivity testing of Schottky diodes and photo detectors in detecting α particles has been designed and built. Commercial SiC Schottky diodes and Si and SiC photo diodes have been electronically characterized to determine the configuration of the front-end electronics to analyze the radiation response. After repackaging the diodes, the room-temperature response of a SiC Schottky diode was compared to a Si PIN diode optimized for radiation detection. The Si PIN diode had only a slightly better signal strength and signal-to-noise ratio, but the SiC diode showed much lower noise. The testing of an optimized SiC diode may improve the signal strength, which will improve the signal to noise ratio. No testing was done at the temperature extremes expected on the lunar surface to determine signal stability of the two semiconductor materials. A concept for utilizing scintillating fiber ribbon for use as a dosimeter was outlined, and further investigations are needed to determine the technologies required to produce a proof-of-concept and compare to the semiconductor devices.

We are leveraging our efforts in radiation detection to investigate small and large area scintillating and MEMS devices for sensitivity to radiation and to compare with commercial devices. If these initial results look promising as a path for the design and fabrication of a prototype solid state dosimeter, further

testing would be required in conjunction with other researchers in the space radiation field over the next few years. The long term objective of this effort is to provide a compact, low power active electronic dosimetry system that would not be adversely affected by radiation, with improved sensitivity and detection capability for real-time monitoring of lunar EVA conditions.

References

1. Johnson, A.S.; Badhwar, G.D.; Golightly, M.J.; Hardy, A.C.; Konradi, A.; and Yang, T.C.: "Spaceflight Radiation Health Program at the Lyndon B. Johnson Space Center," NASA TM-104782 (1993).
2. Cucinotta, F.A.; Kim, M.-H. Y.; George, K.A.; Wu, H.: "Risk of Skin Cancer from Space Radiation," Chapter 11 of Radiation Protection Studies of International Space Station Extravehicular Activity Space Suits, ed. F.A. Cucinotta, et al., NASA/TP—2003-212051 (2003) 171–176.
3. Turner, R.: "Living With a Star Support to Human Space Flight and Human Exploration and Development of Space," LWS Community Workshop (2000).
4. DOE (U.S. Department of Energy): "Radiological Control", DOE-STD-1098-99 (2004)
5. Man-Systems Integration Standards, NASA–STD–3000, vol. I, Rev. B (July 1995).
6. Sulzman, F.; Cucinotta, F.; Golightly, M.; Schimmerling, W.: "Radiation Dosimetry Working Group Final Report" (September 30, 2003).
7. Weyland, M.; private communication to J. Wrbanek, May 26, 2005.
8. Vetter, R.J.; et al.: Operational Radiation Safety Program for Astronauts in Low Earth Orbit: A Basic Framework, NCRP Report No. 142 (2002).
9. Kohl, F.; Sutliff, T.; Nall, M.: "GRC outbrief of Zero-Based Review process—A Life Support and Habitation perspective (with a little Human Health and Performance)" (February 7, 2005).
10. NASA/UL: Strategic Program Plan for Space Radiation Health Research, Life Sciences Division, Office of Life and Microgravity Sciences and Applications (NASA HQ, 1998).
11. Fullerton, R.: "The Future of EVA Technologies" (November 6, 2001).
12. Image Source/Credit: "X28 flare in EIT 195," Solar & Heliospheric Observatory (SOHO). SOHO is a project of international cooperation between ESA and NASA.
13. Space Studies Board, National Research Council: Radiation Hazards to Crews of Interplanetary Missions (National Academy Press, 1996).
14. Thomas, G.: "EVA Technology Development Roadmap" (August 13, 2002).
15. Duke, M.B.; Hoffman, S.J.; Snook, K.: "Lunar Surface Reference Missions: A Description of Human and Robotic Surface Activities," NASA/TP—2003-210793 (2003).
16. BRCP (Bioastronautics Roadmap Control Panel): Bioastronautics Roadmap: A Risk Reduction Strategy for Human Space Exploration, NASA/SP—2004-6113 (2004).
17. Simonsen, L.C.: "Background Information for Ionizing Radiation Protection" (August 2000).
18. Knoll, G.F.: Radiation Detection and Measurement (John Wiley & Sons, Inc., New York, 2000).
19. Ruddy, F.H.; Dulloo, A.R.; Seidel, J.G.; Palmour, J.W.; and Singh, R.: "The charged particle response of silicon carbide semiconductor radiation detectors," *Nucl. Instr. and Meth. A* 505 (2003) 159–162.
20. Seshadri, S.; Dulloo, A.R.; Ruddy, F.H.; Seidel, J.G.; and Rowland, L.B.: "Demonstration of an SiC Neutron Detector for High-Radiation Environments," *IEEE Trans. Electron. Dev.* 46 (1999) 567–571.
21. Lutz, G.: "Semiconductors as Detectors," Semiconductor Radiation Detectors: Device Physics (Springer, Berlin, 1999).
22. Sellin, P.J.; Vaitkus, J.: "New materials for radiation hard semiconductor detectors," *Nucl. Instr. and Meth. A* 557 (2006) 479–489.
23. Ruchti, R.C.: "The Use of Scintillating Fibers for Charged-Particle Tracking," *Annu. Rev. Nucl. Part. Sci.* 46 (1996) 281–319.
24. Bross, A.; Crisler, M.; Kross, B.; and Wrbanek, J.: "Scintillating fiber ribbon - tungsten calorimeter," *Nucl. Instr. and Meth. A* 286 (1-2) (1990) 69–72. FERMILAB-TM-1588 (July 1989).

25. Hunter, G.W.; Neudeck, P.G.; Xu, J.; Lucko, D.; Trunek, A.; Artale, M.; Lampard, P.; Androjna, D.; Makel, D.; Ward, B.; Liu, C.C.: "Development of SiC-Based Gas Sensors For Aerospace Applications," *Mat. Res. Soc. Symp. Proc.* 815 (2004) 287–297.
26. SRIM, The Stopping and Range of Ions in Matter, Software Package, Ver. 2003.26, Ziegler, J.F and Beirsack, J.P. (SRIM.org), Annapolis, MD, 2004.
27. Barber, B.P.; Wu, C.C.; Lofstedt, R.; Roberts, P.H.; and Putterman, S.J.: "Sensitivity of sonoluminescence to experimental parameters," *Phys. Rev. Lett.* 72 (9) 1380–1383 (February 1994).
28. Moss, W.C.; Clarke, D.B.; White, J.W.; and Young, D.A.: "Sonoluminescence and the prospects for table-top micro-thermonuclear fusion," *Physics Letters A* 211 (2) pp. 69–74 (February 1996).
29. Taleyarkhan, R.P.; West, C.D.; Cho, J.S.; Lahey Jr., R.T.; Nigmatulin, R.I.; Block, R.C.: "Evidence for Nuclear Emissions During Acoustic Cavitation," *Science* 295 (March 2002), pp. 1868–1873.
30. Crum, L.: "Sonofusion: Star in a Jar?" *Science Forum Colloquium Series*, University of Washington (November 21, 2003). URL: <http://www.washington.edu/research/scienceforum/pdfs/Crum.pdf> [cited 3 February 2004].
31. Wrbanek, J.D.; Fralick, G.C.; Wrbanek, S.Y.; and Weiland, K.E.: "Sonoluminescence: A Galaxy of Nanostars Created in a Beaker," NASA TM-2005-213419 (2005) 47–8.
32. Stewart, C.R.: Extravehicular Mobility Unit Systems Training Workbook: EMU SYS 21002 Revision B, JSC-19450, Rev. B (September 1999).

REPORT DOCUMENTATION PAGEForm Approved
OMB No. 0704-0188

Public reporting burden for this collection of information is estimated to average 1 hour per response, including the time for reviewing instructions, searching existing data sources, gathering and maintaining the data needed, and completing and reviewing the collection of information. Send comments regarding this burden estimate or any other aspect of this collection of information, including suggestions for reducing this burden, to Washington Headquarters Services, Directorate for Information Operations and Reports, 1215 Jefferson Davis Highway, Suite 1204, Arlington, VA 22202-4302, and to the Office of Management and Budget, Paperwork Reduction Project (0704-0188), Washington, DC 20503.

1. AGENCY USE ONLY (Leave blank)		2. REPORT DATE January 2007	3. REPORT TYPE AND DATES COVERED Technical Memorandum	
4. TITLE AND SUBTITLE Micro-Fabricated Solid-State Radiation Detectors for Active Personal Dosimetry			5. FUNDING NUMBERS WBS 561581.02.08.03.05.05	
6. AUTHOR(S) John D. Wrbanek, Susan Y. Wrbanek, Gustave C. Fralick, and Liang-Yu Chen				
7. PERFORMING ORGANIZATION NAME(S) AND ADDRESS(ES) National Aeronautics and Space Administration John H. Glenn Research Center at Lewis Field Cleveland, Ohio 44135-3191			8. PERFORMING ORGANIZATION REPORT NUMBER E-15810	
9. SPONSORING/MONITORING AGENCY NAME(S) AND ADDRESS(ES) National Aeronautics and Space Administration Washington, DC 20546-0001			10. SPONSORING/MONITORING AGENCY REPORT NUMBER NASA TM-2007-214674	
11. SUPPLEMENTARY NOTES John D. Wrbanek, Susan Y. Wrbanek, and Gustave C. Fralick, NASA Glenn Research Center; Liang-Yu Chen, Ohio Aerospace Institute, 22800 Cedar Point Road, Brook Park, Ohio 44142. Responsible person, John D. Wrbanek, organization code RIS, 216-433-2077.				
12a. DISTRIBUTION/AVAILABILITY STATEMENT Unclassified - Unlimited Subject Category: 35 Available electronically at http://gltrs.grc.nasa.gov This publication is available from the NASA Center for AeroSpace Information, 301-621-0390.			12b. DISTRIBUTION CODE	
13. ABSTRACT (Maximum 200 words) Active radiation dosimetry is important to human health and equipment functionality for space applications outside the protective environment of a space station or vehicle. This is especially true for long duration missions to the moon, where the lack of a magnetic field offers no protection from space radiation to those on extravehicular activities. In order to improve functionality, durability and reliability of radiation dosimeters for future NASA lunar missions, single crystal silicon carbide devices and scintillating fiber detectors are currently being investigated for applications in advanced extravehicular systems. For many years, NASA Glenn Research Center has led significant efforts in silicon carbide semiconductor technology research and instrumentation research for sensor applications under extreme conditions. This report summarizes the technical progress and accomplishments toward characterization of radiation-sensing components for the recommendation of their fitness for advanced dosimetry development.				
14. SUBJECT TERMS Dosimeters; Extravehicular activity; Semiconductors (materials); Scintillation counters; Real time operation; Extraterrestrial radiation			15. NUMBER OF PAGES 23	
			16. PRICE CODE	
17. SECURITY CLASSIFICATION OF REPORT Unclassified	18. SECURITY CLASSIFICATION OF THIS PAGE Unclassified	19. SECURITY CLASSIFICATION OF ABSTRACT Unclassified	20. LIMITATION OF ABSTRACT	

