

**CLASS 476, FRICTION GEAR TRANSMISSION SYSTEMS OR COMPONENTS****SECTION I - CLASS DEFINITION**

This is the class for friction gear power transmission and elements thereof, such transmission being defined as an assembly of parts wherein rotary motion is transmitted from an input body to an output body by surface friction of rolling contact between parts associated with said input and output bodies.

- (1) Note. A nominal recitation of a device for applying power to, or receiving power from, a structure of this class will not exclude a patent from being placed in this class.

**SECTION II - LINES WITH OTHER CLASSES AND WITHIN THIS CLASS**

A method or apparatus for manufacturing a device of this class is not found in Class 476, but is found in an appropriate manufacturing class. See, for example, Class 29, Metal Working, subclasses 893+ and other subclasses in Class 29 directed to process and apparatus of mechanical manufacture.

**SECTION III - REFERENCES TO OTHER CLASSES****SEE OR SEARCH CLASS:**

- 74, Machine Element or Mechanism, subclass 721 for systems including plural power paths to or from friction gearing; subclass 745 for plural ratio change gearing in series, one of which may be friction gearing.
- 180, Motor Vehicles, for combinations of significant vehicle structure which may include friction gearing, especially subclass 368 for friction gearing combinations.
- 184, Lubrication, for lubrication generally, especially subclass 6.12 for lubrication systems for gearing.
- 192, Clutches and Power-Stop Control, subclasses 3.51+ for controls for a friction transmission and clutch; and subclasses 4+ for a transmission control and brake.
- 474, Endless Belt Power Transmission Systems or Components, for friction power transmission using an endless, flexible friction drive belt.

475, Planetary Gear Transmission Systems or Components, subclasses 165+ for an eccentrically driven friction gear; subclasses 183+ for planetary friction gearing; and subclasses 214+ for a nonplanetary friction gear transmission combined with a planetary transmission.

477, Interrelated Power Delivery Controls, Including Engine Control, especially subclasses 37+ for interrelated control between a motor and a continuously variable friction transmission.

**SUBCLASSES****1 CONDITION RESPONSIVE RATIO CHANGE:**

This subclass is indented under the class definition. Subject matter wherein means are provided to change the rotational velocity of the output body divided by the rotational velocity of the input body, said means having mechanism to sense a condition or change of condition in the environment of the friction gear transmission; and, in response to such sensing, effect said change of rotational velocity.

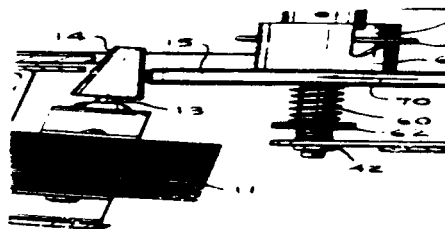
**SEE OR SEARCH CLASS:**

477, Interrelated Power Delivery Controls, Including Engine Control, especially subclasses 37+ for interrelated control between a motor and a continuously variable friction transmission.

**2 Fluid control:**

This subclass is indented under subclass 1. Subject matter wherein said means to change the rotational velocity are actuated by hydraulic or pneumatic energy.

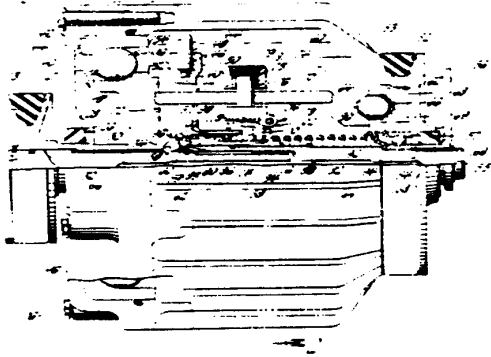

- 3 And electric or magnetic control:**  
This subclass is indented under subclass 2. Subject matter which further includes an electrical or magnetic actuator to influence said means to change the rotational velocity.

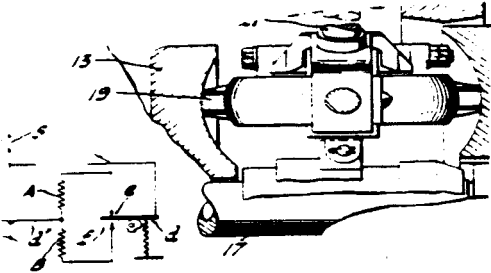

- 4 Electric or magnetic control:**  
This subclass is indented under subclass 1. Subject matter wherein said means to change the rotational velocity are actuated by electric or magnetic energy.

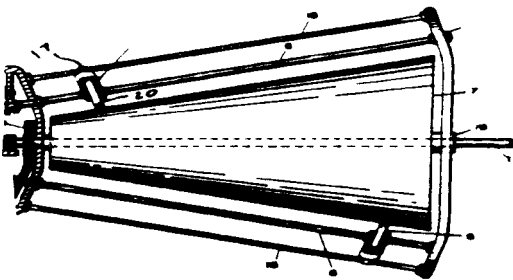

SEE OR SEARCH THIS CLASS, SUB-CLASS:

3, for electrical control combined with fluid control.

- 5 Centrifugal actuator:**  
This subclass is indented under subclass 1. Subject matter wherein said means include a mass rotatable about an axis with a member of said friction transmission; and wherein a component of force acting on said mass by said rotation in a direction away from said rotational axis is used to move a transmission component by said mass to effect said change of rotational velocity.

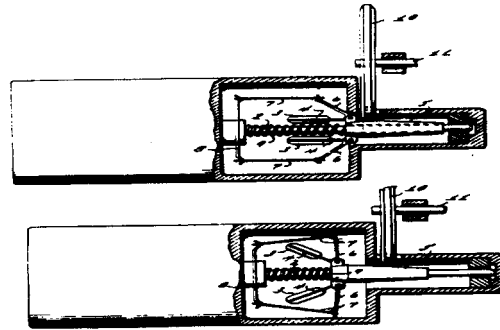

- 6 RATIO CHANGE BY EXPANSION OR COMPRESSION OF FLEXIBLE FRICTION SURFACE:**  
This subclass is indented under the class definition. Subject matter wherein at least one of said surfaces of a part in rolling contact is formed of pliable material; and wherein means are provided to change the radial distance from the axis of rotation of said part to its rolling contact surface by expanding or contracting its pliable surface so as to vary the rotational velocity of the output body divided by the rotational velocity of the input body.

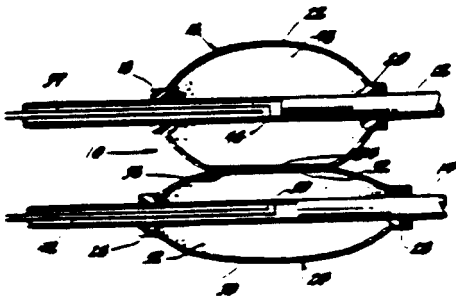

**7 WITH FRICTION ENHANCING FLUID:**  
 This subclass is indented under the class definition. Subject matter and further including means for applying a flowable material to a rolling contact surface; said material having a characteristic that increases the resistance to relative slipping movement between said rolling contact surfaces.

**8 WITH LUBRICATION:**  
 This subclass is indented under the class definition. Subject matter and further including means for applying a substance between contacting moving parts to reduce friction between the contacting parts.

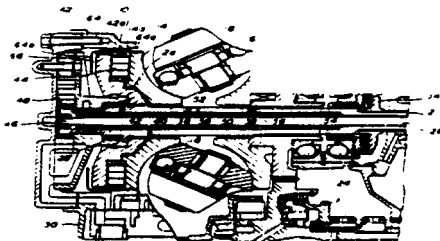

SEE OR SEARCH CLASS:  
 184, Lubrication, for lubricating devices and systems in general.

**9 FLUID CONTROL:**  
 This subclass is indented under the class definition. Subject matter wherein means are provided to regulate the operation of said transmission, and such means is actuated by hydraulic or pneumatic energy.

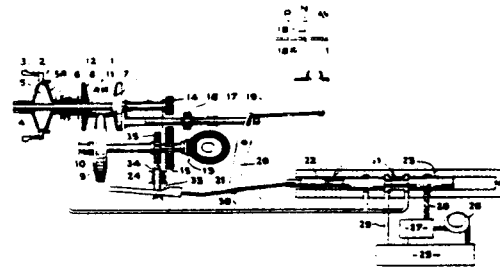

SEE OR SEARCH THIS CLASS, SUB-CLASS:  
 2+, for fluid control of condition responsive ratio change.

**10 Of toroidal transmission:**  
 This subclass is indented under subclass 9. Subject matter wherein said transmission includes first and second surfaces facing each other and having a common rotational axis, said first surface having a semicircular concave portion spaced from its rotational axis, and said second surface having a semicircular concave portion spaced from its rotational axis and facing said concave portion of said first surface so that said concave surface portions of said first and second surface together define a doughnut-shaped cavity surrounding said rotational axis; and said transmission further includes an idler member rotatable about its own axis and positioned in said cavity to transfer rotary motion from said first to said second surface.

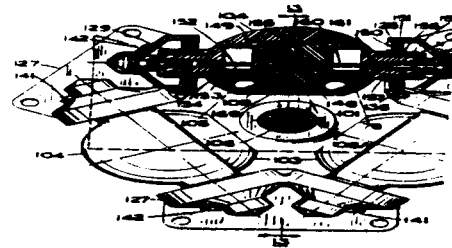

**11 ELECTRIC OR MAGNETIC CONTROL:**  
 This subclass is indented under the class definition. Subject matter wherein means are provided to regulate the operation of said transmission, and such means are actuated by electric or magnetic energy.

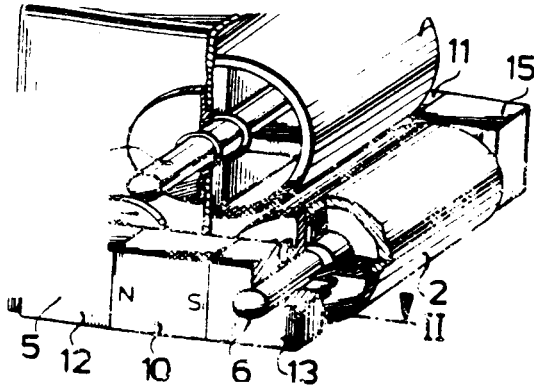

SEE OR SEARCH THIS CLASS, SUB-CLASS:

4, for electric or magnetic control of condition responsive ratio change.

**12 WITH INDICATOR OR ALARM:**

This subclass is indented under the class definition. Subject matter and further including a device for indicating a condition thereof or for providing a warning that an undesirable condition exists.

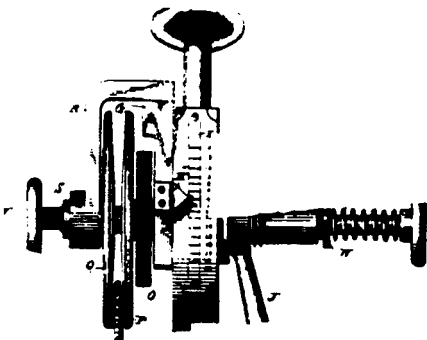

SEE OR SEARCH CLASS:

116, Signals and Indicators, for indicators and alarms in general.

**13 CYCLICAL OUTPUT:**

This subclass is indented under the class definition. Subject matter wherein means are provided to vary the rotational speed of said output body according to a predetermined pattern without operator intervention.

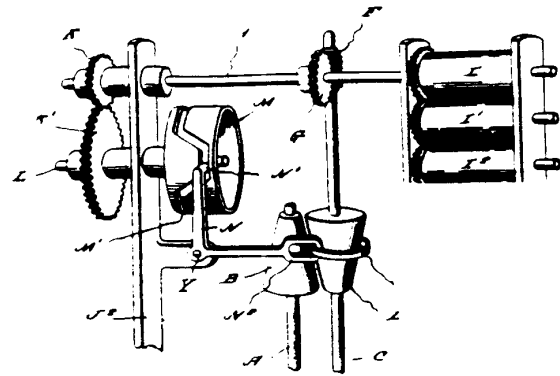

**14 WITH TRANSMISSION COOLING OR HEATING MEANS:**

This subclass is indented under the class definition. Subject matter and also including means to alter the temperature of an element thereof during operation.

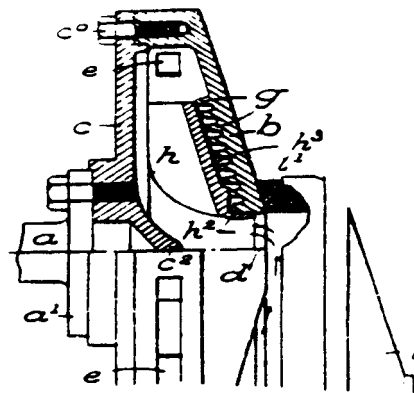

**15 FORWARD AND REVERSE:**

This subclass is indented under the class definition. Subject matter wherein means are provided to drive said output body in both a clockwise and a counterclockwise direction.

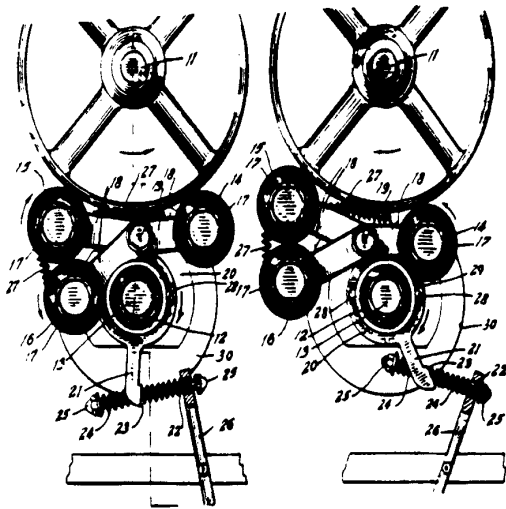

**16 Flexible belt in drive train:**  
 This subclass is indented under subclass 15. Subject matter wherein one of a group of interconnected elements providing rotary drive between said input and output bodies includes an endless flexible member.

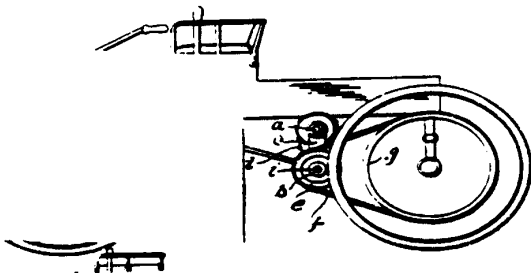

SEE OR SEARCH CLASS:  
 474, Endless Belt Power Transmission Systems or Components, for frictional power transmission via an endless flexible member.

**17 Drive in one direction by direct engagement of belt pulleys:**  
 This subclass is indented under subclass 16. Subject matter wherein said endless flexible member extends between and drivingly engages a pair of wheels; and wherein means is provided to provide direct driving contact between surfaces of said wheels to drive said

output body in said clockwise or counterclockwise direction.



**18 Variable speed in forward or reverse:**  
 This subclass is indented under subclass 15. Subject matter wherein means are provided to change the rotational velocity of said output body in either said clockwise or counterclockwise direction.

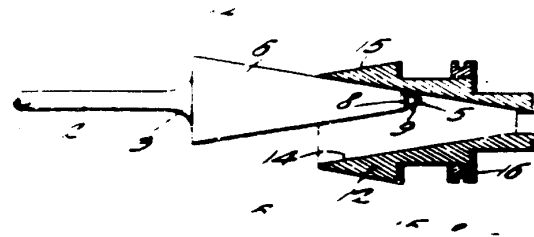

SEE OR SEARCH THIS CLASS, SUBCLASS:  
 47+, and 59+, for variable speed friction gearing wherein a reversing feature may be disclosed but not claimed.

**19 With toothed gears in drive train:**  
 This subclass is indented under subclass 18. Subject matter wherein one of a group of interconnected elements providing rotary drive between said input and output bodies includes members having intermeshing teeth to transmit rotation from one to the other of said members.

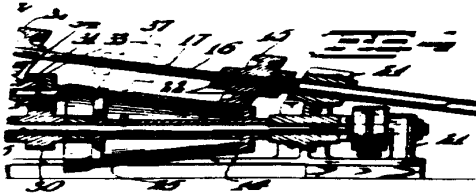

**SEE OR SEARCH CLASS:**

- 74, Machine Element or Mechanism, for gearing, per se, which has intermeshing teeth.
- 475, Planetary Gear Transmission Systems or Components, for planetary gearing having intermeshing teeth.

**20 Stepped ratio change:**

This subclass is indented under subclass 18. Subject matter wherein means are provided to vary the rotational velocity of the output body divided by the rotational velocity of the input body, said velocity being varied in a finite number of increments.

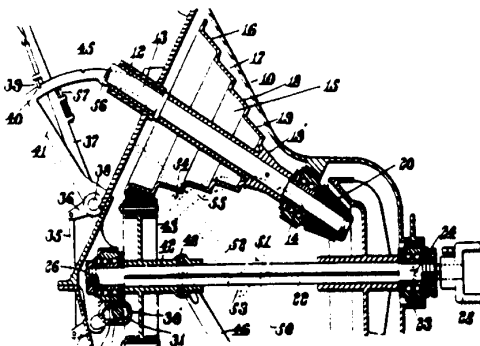

**SEE OR SEARCH THIS CLASS, SUBCLASS:**

- 59+, for stepped ratio change friction gearing wherein a reversing feature may be disclosed but not claimed.

**21 Intermediate idler between input and output gears:**

This subclass is indented under subclass 18. Subject matter wherein said rotary motion transmitting parts include a first element rotatable by said input body, a second element rotatably connected to said output body and a third element rotatable about its own axis; said third

element having surface portions sequentially contacting said first and second elements to transmit rotary motion from said first element to said second element via said third element by surface friction of rolling contact between said third element and said first and second elements.

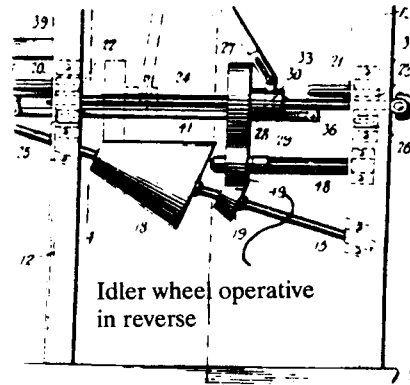

**SEE OR SEARCH THIS CLASS, SUBCLASS:**

- 50+, for similar gearing wherein a reversing feature may be disclosed but not claimed.

**22 Idler between conoidal gears:**

This subclass is indented under subclass 21. Subject matter wherein said first and second elements are in the shape of a cone or the frustum of a cone.

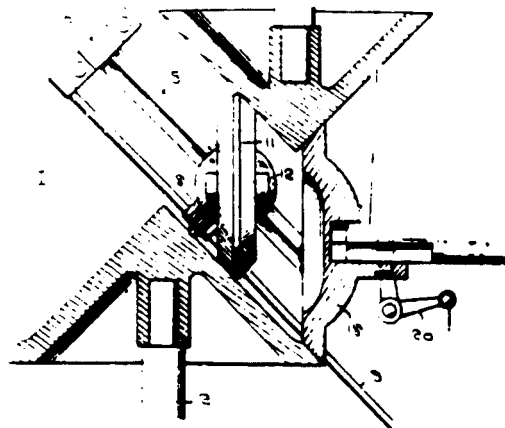

SEE OR SEARCH THIS CLASS, SUB-CLASS:

51, for similar gearing wherein a reversing feature may be disclosed but not claimed.

**23 Idler between flat discs:**

This subclass is indented under subclass 21. Subject matter wherein said first and second elements comprise flat circular plates with said third element contacting the flat surfaces of said plates.

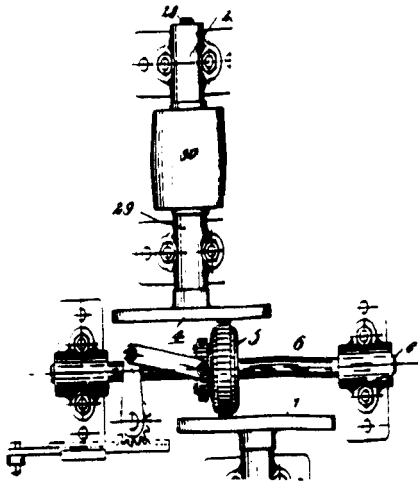

SEE OR SEARCH THIS CLASS, SUB-CLASS:

54, for similar gearing wherein a reversing feature may be disclosed but not claimed.

**24 Driving and driven gears on perpendicular axes:**

This subclass is indented under subclass 18. Subject matter wherein said rolling frictional contact is between a first part having a first rotational axis and a second part having a second rotational axis; said second axis being at an angle of ninety degrees relative to said first axis.

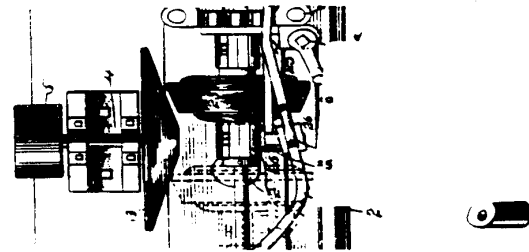

SEE OR SEARCH THIS CLASS, SUB-CLASS:

56+, for similar gearing wherein a reversing feature may be disclosed but not claimed.

**25 Drive in forward direction by direct clutch:**

This subclass is indented under subclass 15. Subject matter wherein means are provided to directly connect said input body to said output body for common directional rotation, with no ratio change, in one of said rotational directions.

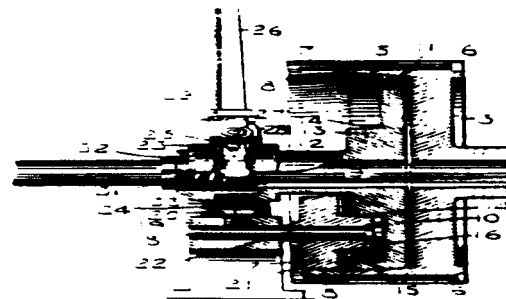

**26 Driving and driven gears on angularly related axes:**

This subclass is indented under subclass 15. Subject matter wherein said rolling frictional contact is between a first part having a first rotational axis and a second part having a second rotational axis; said second rotational axis being different from and intersecting said first rotational axis.

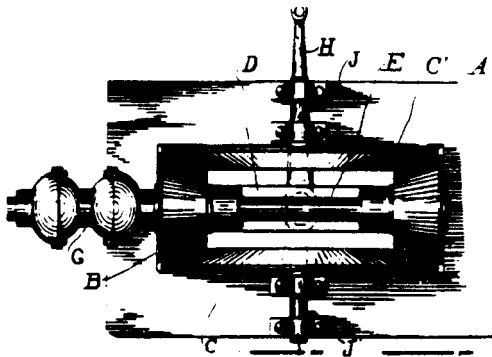

SEE OR SEARCH THIS CLASS, SUB-CLASS:

68+, for similar gearing wherein a reversing feature may be disclosed but not claimed.

**27 PLURAL GEARING IN SERIES:**

This subclass is indented under the class definition. Subject matter wherein in addition to said parts transmitting rotary motion by surface friction of rolling contact there is located, in series therewith, a second assembly of elements transmitting rotary motion from the input body to the output body by rolling contact between engaging surfaces of said elements.

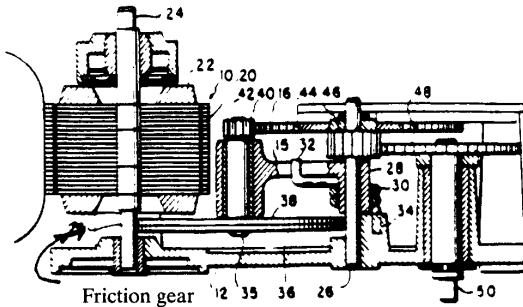

Friction gear

SEE OR SEARCH CLASS:

74, Machine Element or Mechanism, subclass 745 for plural ratio change gearing in series.

**28 Flexible belt in drive train:**

This subclass is indented under subclass 27. Subject matter wherein said second assembly of elements includes an endless flexible member.

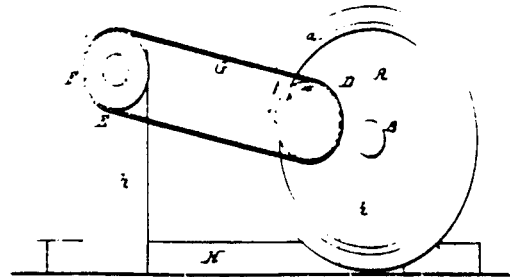

SEE OR SEARCH THIS CLASS, SUB-CLASS:

16, for a flexible belt in a drive train of forward and reverse gearing systems.

**29 Friction gearing is ratio change gearing:**

This subclass is indented under subclass 28. Subject matter wherein said parts transmitting rotary motion by surface friction of rolling contact include means to vary the rotational velocity of the output body divided by the rotational velocity of the input body.

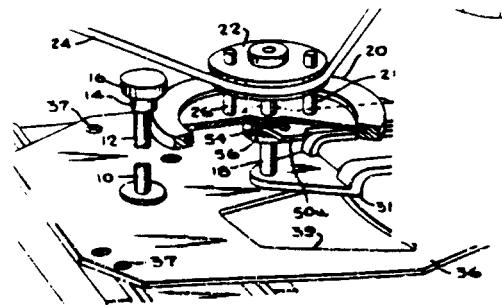

**30 Friction gearing is stepless ratio change:**

This subclass is indented under subclass 29. Subject matter wherein said rotational velocity is varied in an infinite number of increments.



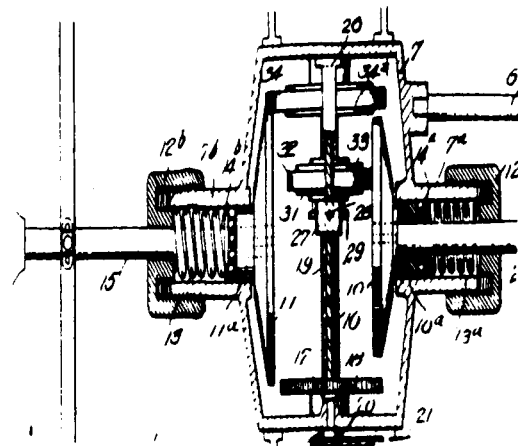
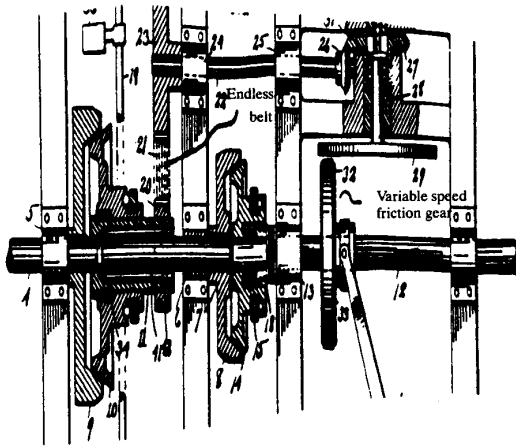

**31 Plural friction gearing in series:**  
 This subclass is indented under subclass 27. Subject matter wherein said second assembly of elements also includes parts transmitting rotary motion by surface friction of rolling contact.

**33 Friction gearing is ratio change gearing:**  
 This subclass is indented under subclass 27. Subject matter wherein said parts transmitting rotary motion by surface friction of rolling contact include means to vary the rotational velocity of the output body divided by the rotational velocity of the input body.

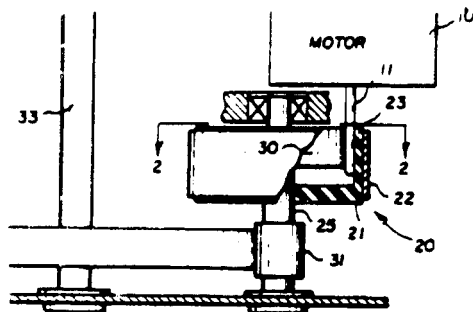

**32 Ratio change gearing and nonratio change gearing:**  
 This subclass is indented under subclass 31. Subject matter wherein one of said assembly of parts transmits a constant rotational velocity; and wherein the other assembly of parts transmits a variable rotational velocity.

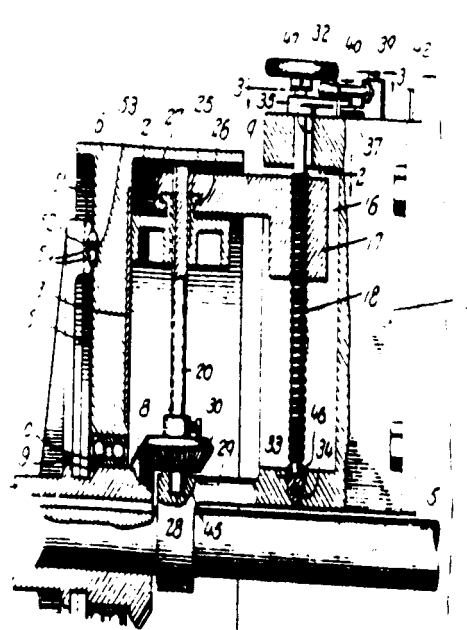

**34 One gear is toothed bevel gear:**  
 This subclass is indented under subclass 27. Subject matter wherein said second assembly of elements includes members having intermeshing radial teeth transmitting rotary

motion, and wherein the radial teeth on said members are inclined with respect to the rotational axis of said members.

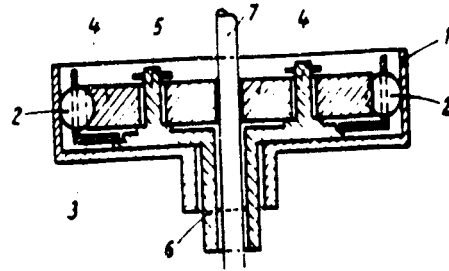
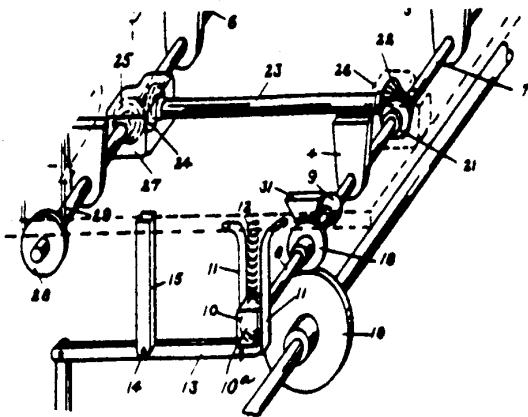

SEE OR SEARCH CLASS:

475, Planetary Gear Transmission Systems or Components, subclass 196 for a spherical friction planetary gear.

**35 One gear is worm gear:**

This subclass is indented under subclass 27. Subject matter wherein said second assembly of elements for transmitting rotary motion includes a rotary body having radial teeth on the rim, with the edges of the teeth arranged as a helix extending around the rotational axis of the body.

**37 With condition responsive means to vary contact pressure:**

This subclass is indented under subclass 36. Subject matter including means to sense a condition or change of condition in the environment of said friction gear transmission; and, in response to such sensing, said means act to increase pressure of frictional contact between said rotary motion transmitting parts.

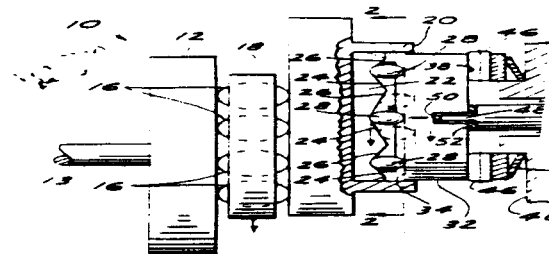
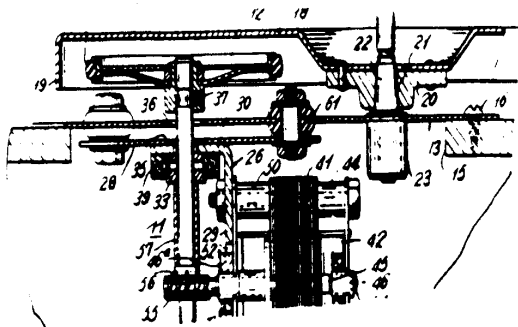

**36 FRICTION GEAR IS BALL:**

This subclass is indented under the class definition. Subject matter wherein said rolling contact parts include a spherical element for transmitting rotary motion by surface friction of rolling contact between said spherical element and another element.

SEE OR SEARCH THIS CLASS, SUBCLASS:

9+, for condition responsive fluid control to increase contact pressure; and subclasses 41, 48, and 61+ for other transmissions having condition responsive pressure variation.

**38 Variable ratio:**

This subclass is indented under subclass 36. Subject matter which includes means to change the rotational velocity of the output body divided by the rotational velocity of the input body.

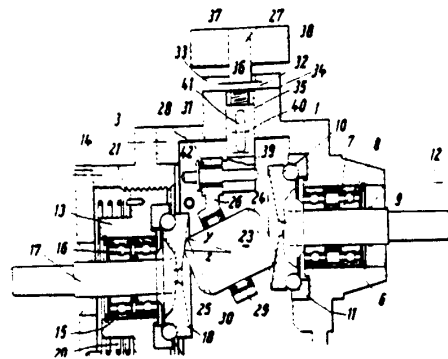
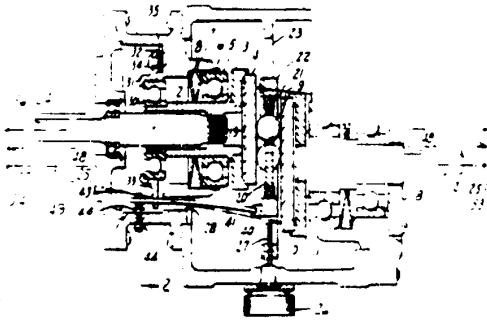

SEE OR SEARCH CLASS:

475, Planetary Gear Transmission Systems or Components, subclass 189, for a spherical friction planetary gear having means for ratio change.

**39 FRICTION GEAR INCLUDES IDLER ENGAGING FACING CONCAVE SURFACES:**

This subclass is indented under the class definition. Subject matter wherein said rotary motion transmitting parts include a first rotatable element having a first concave surface, a second rotatable element having a second concave surface facing the concave surface of said first rotatable element so as to define a cavity therebetween, and a third rotatable element rotatable about its own axis and mounted in said cavity; said third rotatable element including surface portions in contact with said first and second concave surfaces to transmit rotary motion from said first element to said second element via said third element by surface friction of rolling contact between said contacting surfaces.

**40**

**Toroidal:**

This subclass is indented under subclass 39. Subject matter wherein said first and second concave portions are radially spaced from the axis of rotation of said first and second elements so that said cavity is substantially doughnut-shaped and surrounds the axis of rotation of said first and second elements.

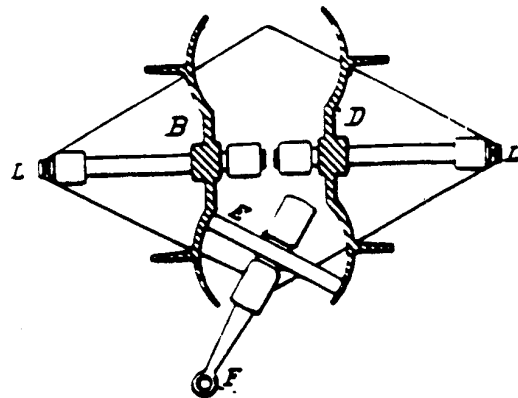

SEE OR SEARCH THIS CLASS, SUBCLASS:

10, for fluid control of a toroidal transmission.

SEE OR SEARCH CLASS:

475, Planetary Gear Transmission Systems or Components, subclass 192 for a frictional toric planetary gear system.

**41 With condition responsive means to vary contact pressure:**

This subclass is indented under subclass 40. Subject matter including means to sense a condition or change of condition in the environment of said friction gear transmission; and, in response to such sensing, said means acts to increase pressure of frictional contact between said rotary motion transmitting parts.

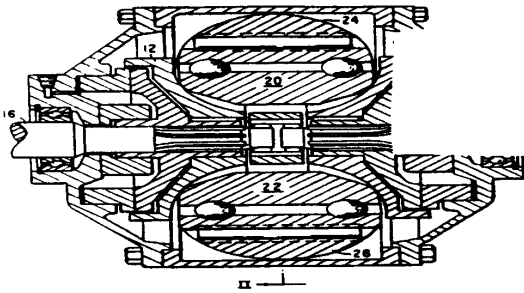

SEE OR SEARCH THIS CLASS, SUBCLASS:

10, for condition responsive fluid control to vary contact pressure in a toroidal transmission, and subclasses 37, 48, and 61+ for other condition responsive pressure variation.

**42 Plural toric cavities:**

This subclass is indented under subclass 40. Subject matter which further includes an additional set of concave portions defining a second substantially doughnut-shaped cavity; said second cavity also including an element rotatable about its own axis and mounted in said second cavity.

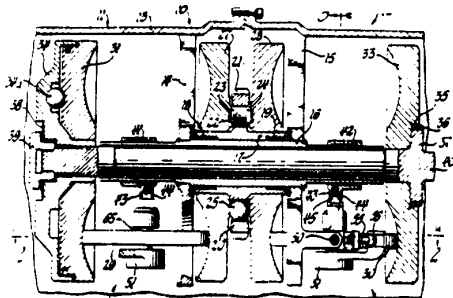

**43 Including threaded means to adjust idler:**

This subclass is indented under subclass 40. Subject matter wherein adjusting means are provided to change the position of said third element in said cavity; and wherein said adjusting means are actuated by rotary movement of a part having a surface in the form of a helix around the axis of rotation of the part.

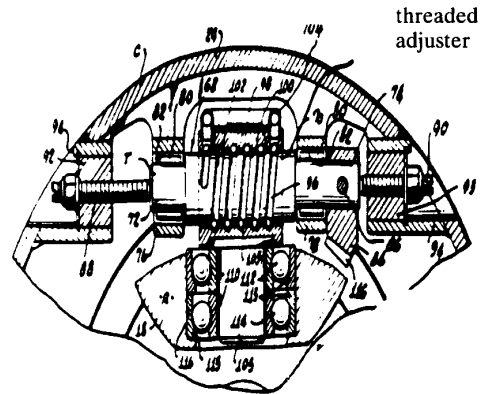

threaded adjuster

**44 Including toothed gearing to adjust idler:**

This subclass is indented under subclass 40. Subject matter wherein adjusting means are provided to change the position of said third element in said cavity; and wherein said adjusting means are actuated by movement of first toothed element that meshes with a second toothed element to move said second element and said adjusting means.

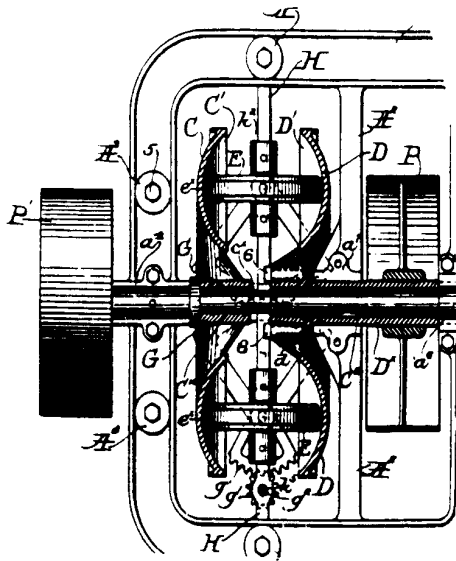

- 45 Including spring means to bias friction surfaces into engagement:**  
 This subclass is indented under subclass 40. Subject matter wherein one of said first, second, or third elements is biased into contact with another of said first, second, or third elements by a resilient member.

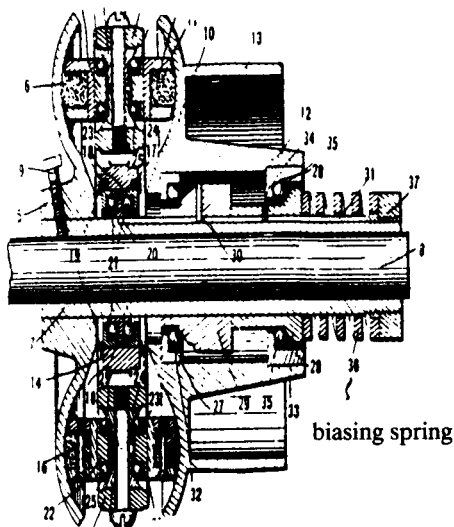

biasing spring

SEE OR SEARCH THIS CLASS, SUB-CLASS:  
 65+, for spring means to urge gears into engagement in other friction transmissions.

- 46 Idler supported by roller bearing:**  
 This subclass is indented under subclass 40. Subject matter wherein said third element is mounted for rotation relative to a holder by rotatable bearings spaced around the axis of rotation of said third element.

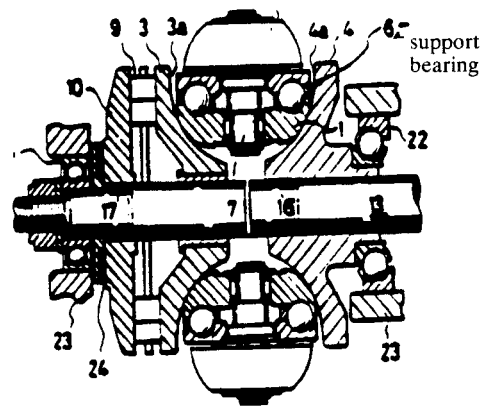

support bearing

SEE OR SEARCH THIS CLASS, SUB-CLASS:  
 70, for other transmissions having roller bearing support for friction gears.

- 47 STEPLESS RATIO CHANGE:**  
 This subclass is indented under the class definition. Subject matter wherein means are provided to vary the rotational velocity of the output body divided by the rotational velocity of the input body, said velocity being varied in an infinite number of increments.

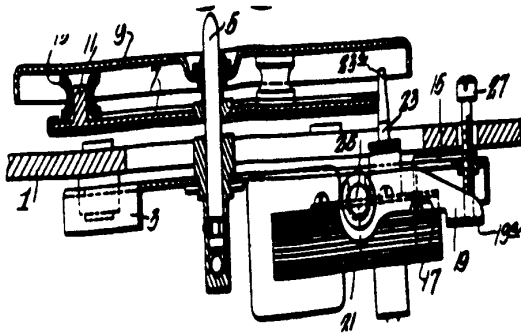

**48 With condition responsive means to vary contact pressure:**

This subclass is indented under subclass 47. Subject matter including means to sense a condition or change of condition in the environment of said friction gear transmission; and, in response to such sensing, said means act to increase pressure of frictional contact between said rotary motion transmitting parts.

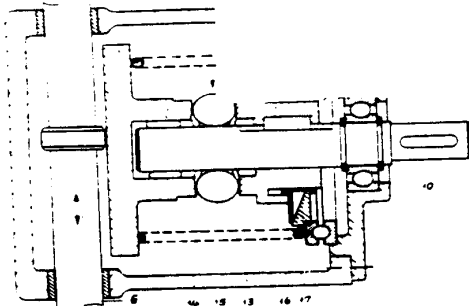

SEE OR SEARCH THIS CLASS, SUBCLASS:

37, 41 and 61+, for other friction gearing transmissions having condition responsive means to vary contact pressure of the gears.

**49 Plural interdigitated disks on parallel axes:**

This subclass is indented under subclass 47. Subject matter wherein said friction gear transmission includes a first plurality of plates spaced from each other along a first rotational axis; and a second plurality of plates spaced from each other along a second rotational axis; said second plates extending into the space between said first plates, and said second plates

contacting said first plates to transmit rotary motion by surface friction of rolling contact.

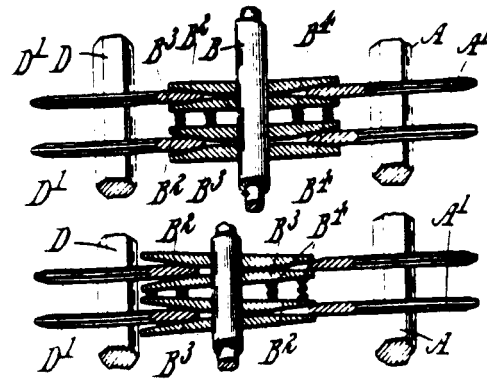

**50 Intermediate idler between driving and driven gears:**

This subclass is indented under subclass 47. Subject matter wherein said rotary motion transmitting parts include a first element rotatable by said input body, a second element rotatably connected to said output body, and a third element rotatable about its own axis; said third element having surface portions sequentially contacting said first and second elements to transmit rotary motion from said first element to said second element via said third element by surface friction of rolling contact between said third element and said first and second elements.

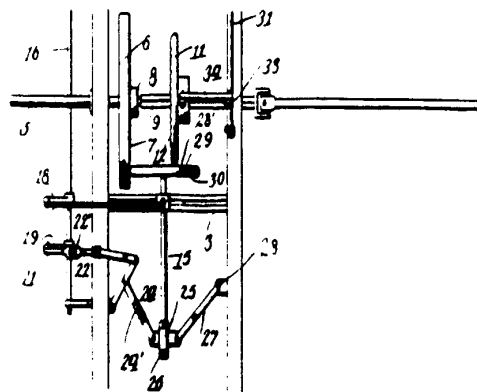

SEE OR SEARCH THIS CLASS, SUBCLASS:

21, for similar structure in forward and reverse gearing.

- 51 Idler between conoidal gears:**  
 This subclass is indented under subclass 50. Subject matter wherein said first and second elements are in the shape of a cone or the frustum of a cone.

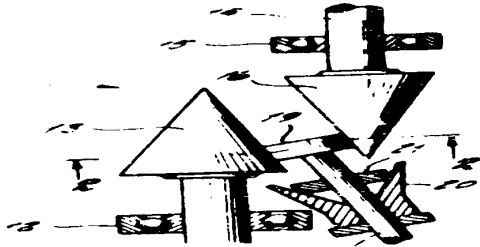

SEE OR SEARCH THIS CLASS, SUB-CLASS:  
 22, for similar structure in forward and reverse gearing.

- 52 Idler is ring:**  
 This subclass is indented under subclass 51. Subject matter wherein said third element is an endless band.

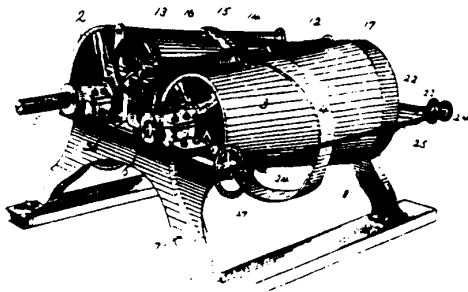

- 53 Rigid:**  
 This subclass is indented under subclass 52. Subject matter wherein said band is inflexible.

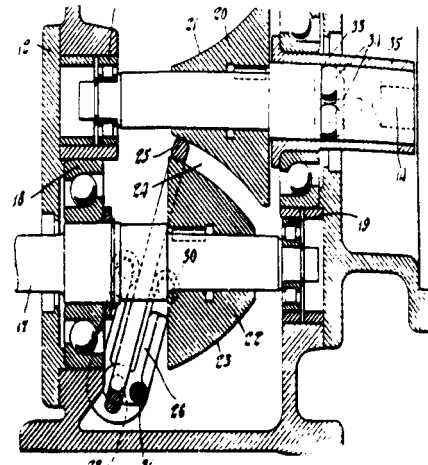

- 54 Idler between flat disks:**  
 This subclass is indented under subclass 50. Subject matter wherein said first and second elements comprise flat circular plates with said third element contacting the flat surfaces of said plates.

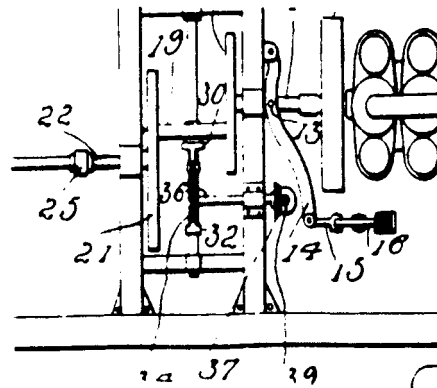

SEE OR SEARCH THIS CLASS, SUB-CLASS:  
 23, for similar structure in forward and reverse gearing.

- 55 Driving and driven gears on nonlinear angularly related axes:**  
 This subclass is indented under subclass 47. Subject matter wherein said rolling frictional contact is between a first part having a first

rotational axis and a second part having a second rotational axis; said second rotational axis being different from and intersecting said first rotational axis.

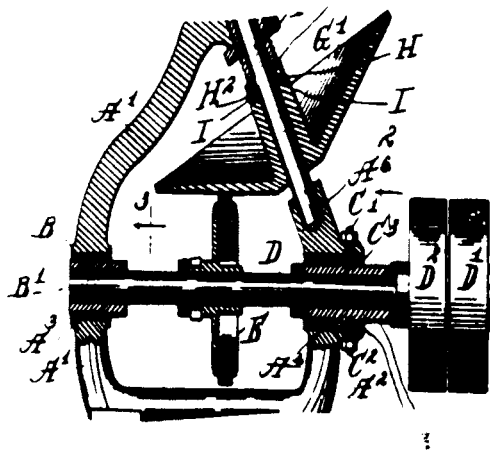

**56 Perpendicular:**  
 This subclass is indented under subclass 55. Subject matter wherein said second axis is at an angle of ninety degrees relative to said first axis.

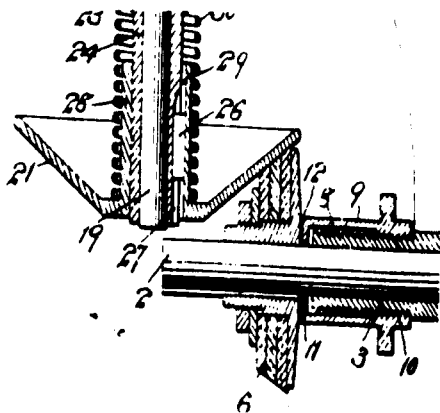

SEE OR SEARCH THIS CLASS, SUB-CLASS:  
 24, for similar structure in forward and reverse gearing.

**57 Disc and wheel:**  
 Subject matter under 56 wherein said first part is a flat, circular plate and said second part is a

circular ring; and wherein rotary motion is transmitted by surface contact between the exterior round surface of the ring and the flat face of the plate.

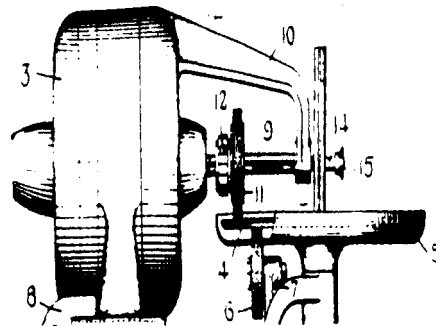

**58 Disc on input shaft:**  
 This subclass is indented under subclass 57. Subject matter wherein said plate is on said input body.

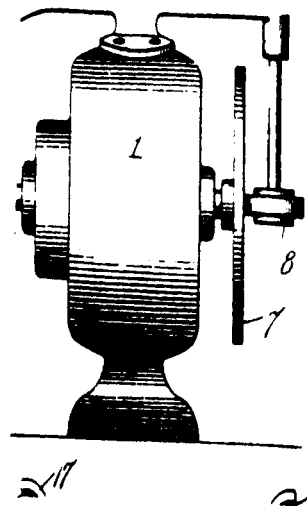

**59 STEPPED RATIO CHANGE:**  
 This subclass is indented under the class definition. Subject matter wherein means are provided to vary the rotational velocity of the output body divided by the rotational velocity of the input body, said velocity being varied in a finite number of increments.



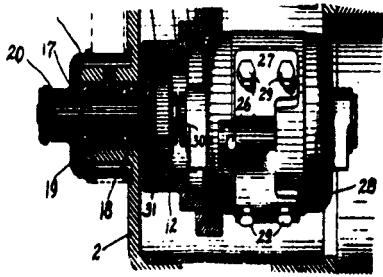

**60 Stepped motor shaft:**  
 This subclass is indented under subclass 59. Subject matter wherein the input body comprises a shaft on a prime mover, said shaft having varied diameters spaced along its length.

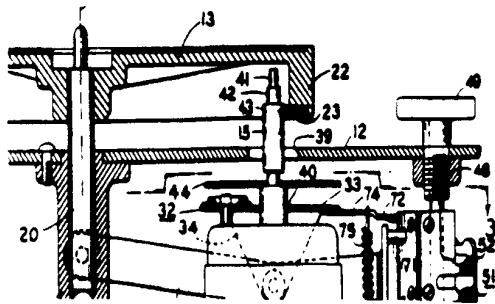

**62 Centrifugal actuator:**  
 This subclass is indented under subclass 61. Subject matter wherein said means include a mass rotatable about an axis with a member of said friction transmission; and wherein a component of force acting on said mass by said rotation in a direction away from said rotational axis is used to move a transmission component by said mass to increase said frictional contact pressure.

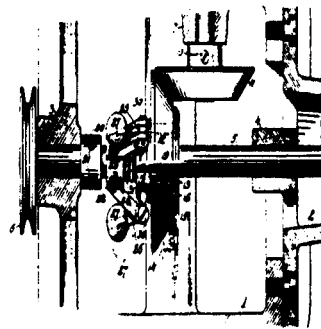

**61 CONDITION RESPONSIVE MEANS TO VARY CONTACT PRESSURE:**  
 This subclass is indented under the class definition. Subject matter including means to sense a condition or change of conditions in the environment of said friction gear transmission; and, in response to such sensing, said means act to increase pressure of frictional contact between said rotary motion transmitting parts.

**63 Ball actuator:**  
 This subclass is indented under subclass 61. Subject matter wherein said means include a spherical member.

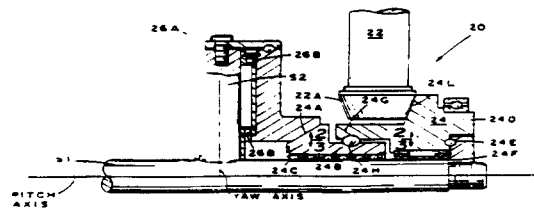
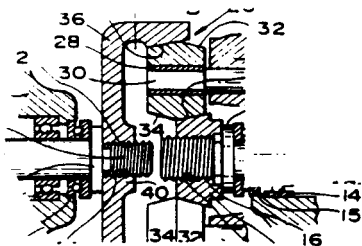

**64 FRICTION GEAR ON SHAFT OF MOVABLY MOUNTED MOTOR:**

This subclass is indented under the class definition. Subject matter wherein one of said parts in frictional rolling contact is mounted on a prime mover shaft; and wherein said prime mover is adjustably mounted on a support therefor to change the position of said one of said parts.

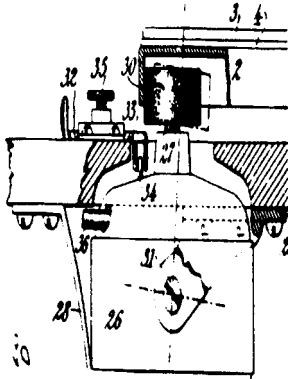

SEE OR SEARCH THIS CLASS, SUBCLASS:

60, for a motor having a stepped shaft, wherein the motor may be movable to bring different stepped portions of the shaft into contact with a driven member to obtain a variable ratio.

**65 SPRING URGES CONTACTING GEARS INTO ENGAGEMENT:**

This subclass is indented under the class definition. Subject matter wherein said parts transmitting rotary motion are biased into rolling contact with each other by a resilient member.

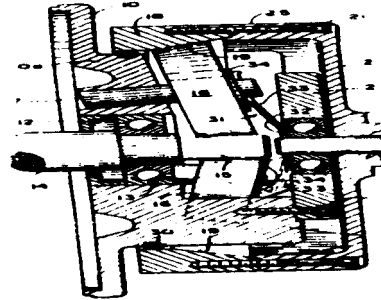

SEE OR SEARCH THIS CLASS, SUBCLASS:

45, for spring means to urge friction gears into engagement in a toroidal transmission.

**66 Coil spring:**

This subclass is indented under subclass 65. Subject matter wherein said resilient member is a helically coiled wire.

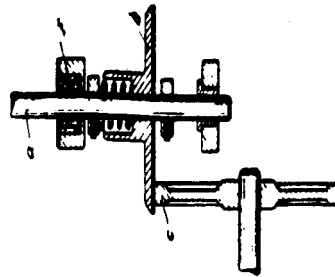

**67 FRICTION TRANSMISSION OR ELEMENT:**

This subclass is indented under the class definition. A transmission as defined in the ... or a device particularly adapted to be used with said transmission.

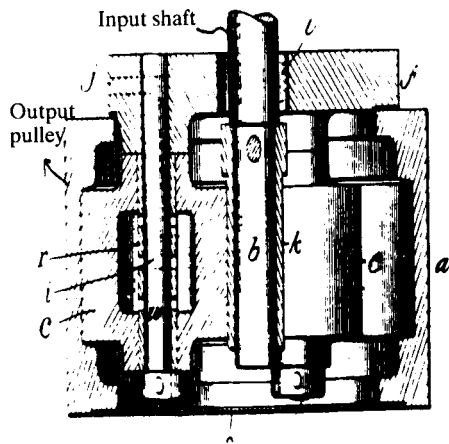

**68 Friction gears on nonlinear angularly related axes:**  
 This subclass is indented under subclass 67. Subject matter wherein said rolling frictional contact is between a first part having a first rotational axis and a second part having a second rotational axis; said second rotational axis being different from and intersecting said first rotational axis.

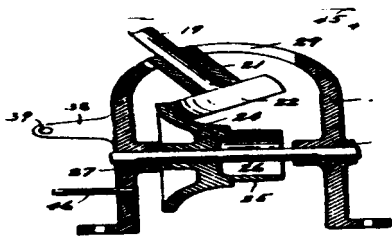

Input shaft; Output pulley

SEE OR SEARCH THIS CLASS, SUBCLASS:  
 24, and 55, for other friction gear transmissions having gears on angularly related axes.

**69 Perpendicular axes:**  
 This subclass is indented under subclass 68. Subject matter wherein said second axis is at an angle of ninety degrees relative to said first axis.

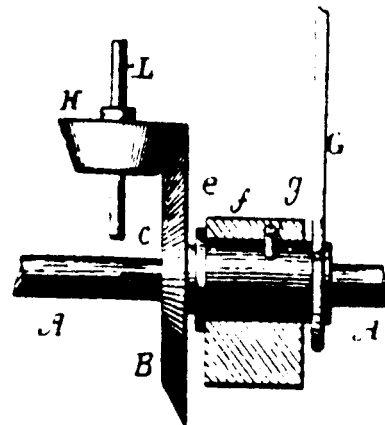

SEE OR SEARCH THIS CLASS, SUBCLASS:  
 24, and 56+, for other friction gear transmissions having gears on perpendicular axes.

**70 Roller bearing between gear and support:**  
 This subclass is indented under subclass 67. Subject matter wherein a part in rolling frictional contact is mounted for rotation relative to a holder, by rotatable bearings spaced about the axis of said part.

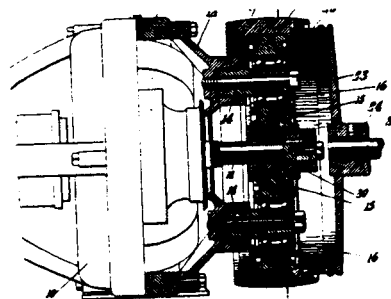

SEE OR SEARCH THIS CLASS, SUBCLASS:  
 46, for other transmissions having roller bearing support for friction gears.

**71 Flexible drive shaft:**  
 This subclass is indented under subclass 67. Subject matter wherein a drive train between said input and output bodies including a bend-

able elongated member rotatable about its longitudinal axis to transmit torque.

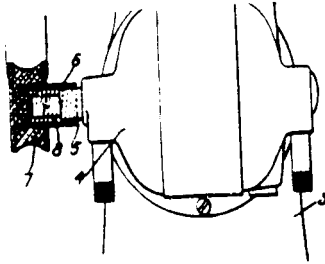

**900 OVERLOAD RELEASE:**

This subclass is indented under the class definition. A collection of patents relating to structure for interrupting the flow of power through a drive train when torque on the output means exceeds a predetermined limit.

END

**72 Particular friction surface:**

This subclass is indented under subclass 67. Subject matter wherein significance is attributed to the configuration of the contacting portion said parts in rolling contact, or to the material from which said portion is formed.

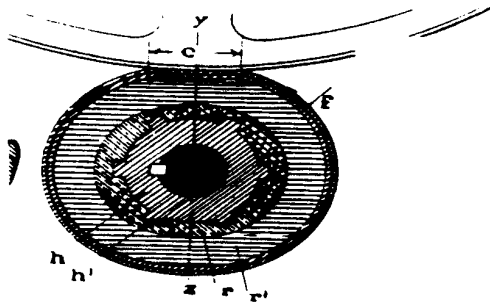

**73 Metallic:**

This subclass is indented under subclass 72. Subject matter wherein said portion is, at least in part, formed from a metal.

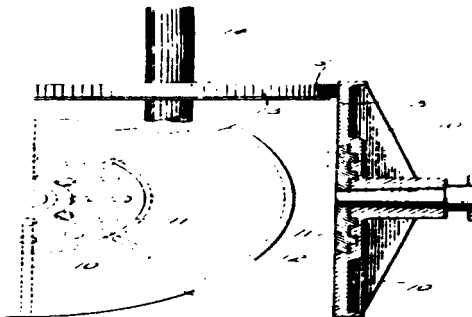

CROSS-REFERENCE ART COLLECTIONS