

CMS Manual System

Pub 100-04 Medicare Claims Processing

Transmittal 572

Department of Health & Human Services

Center for Medicare and &

Medicaid Services

Date: JUNE 1, 2005

Change Request 3871

NOTE: Transmittal 569, dated May 27, 2005 is replaced by Transmittal 572, dated June 1, 2005. Transmittal 569 is replaced, due to Attachment B was inadvertently not attached to the original instruction. All other material remain the same.

SUBJECT: July 2005 Outpatient Prospective Payment System Code Editor (OPPS OCE) Specifications Version 6.2

I. SUMMARY OF CHANGES: This instruction is to inform the Fiscal Intermediaries that the July 2005 Outpatient Prospective Payment System Outpatient Code Editor (OPPS OCE) specifications have been updated with new additions, deletions, and changes.

NEW/REVISED MATERIAL :

EFFECTIVE DATE : July 01, 2005

IMPLEMENTATION DATE : July 05, 2005

Disclaimer for manual changes only: The revision date and transmittal number apply only to red italicized material. Any other material was previously published and remains unchanged. However, if this revision contains a table of contents, you will receive the new/revised information only, and not the entire table of contents.

II. CHANGES IN MANUAL INSTRUCTIONS: (N/A if manual is not updated)

R/N/D	Chapter / Section / SubSection / Title
-------	--

N/A

III. FUNDING:

No additional funding will be provided by CMS; Contractor activities are to be carried out within their FY 2005 operating budgets.

IV. ATTACHMENTS:

Recurring Notification Form

**Unless otherwise specified, the effective date is the date of service.*

Attachment - Recurring Update Notification

Pub. 100-04	Transmittal: 572	Date: June 1, 2005	Change Request 3871
-------------	------------------	--------------------	---------------------

NOTE: Transmittal 569, dated May 27, 2005 is replaced by Transmittal 572, dated June 1, 2005. Transmittal 569 is replaced, due to Attachment B was inadvertently not attached to the original instruction. All other material remain the same.

SUBJECT: July 2005 Outpatient Prospective Payment System Code Editor (OPPS OCE) Specifications Version 6.2

I. GENERAL INFORMATION

A. Background: This notification reflects specifications that were issued for the April revision of the OPPS OCE (Version 6.1). All shaded material in Attachment A reflects changes that were incorporated into the July version of the revised OPPS OCE (Version 6.2).

B. Policy: This notification provides the revised OPPS OCE instructions and specifications that will be utilized under the OPPS for hospital outpatient departments, community mental health centers (CMHC's) and for limited services as defined below when provided in a comprehensive outpatient rehabilitation facility (CORF), home health agency (HHS) not under the Home Health Prospective Payment System or to a hospice patient for the treatment of a non-terminal illness. These instructions and specifications are also utilized by Non-OPPS Outpatient providers with the exception of Non-OPPS hospitals.

Attachment B: Summary of July 2005 Data Changes – This attachment was previously part of the quarterly Update of the Hospital Outpatient Prospective Payment Systems (OPPS) Summary of Payment Policy Changes, in the future this attachment will be a permanent part of the OPPS OCE quarterly updates. Attachment B is the OPPS OCE Summary of Data Changes, effective July 1, 2005. This document summaries all of the modifications made to the APC's, CPT procedure codes, APC assignments, status indicators, modifiers, revenue codes and edits to update the OPPS OCE for the July 1, 2005 quarterly release.

II. BUSINESS REQUIREMENTS

"Shall" denotes a mandatory requirement
"Should" denotes an optional requirement

Requirement Number	Requirements	Responsibility ("X" indicates the columns that apply)								
		F I	R H H I	C a r r i e r	D M E R C	Shared System Maintainers				Other
						F I S S	M C S	V M S	C W F	

Requirement Number	Requirements	Responsibility (“X” indicates the columns that apply)								
		F I	R H I	C a r r i e r	D M E R C	Shared System Maintainers				Other
F I S S	M C S					V M S	C W F			
3871.1	The Shared System Maintainer shall install OPPS OCE Version 6.2 into their systems.	X				X				
3871.2	Intermediaries and RHHI’s shall inform providers of the OPPS OCE changes for Version 6.2 detailed in this recurring change notification.	X	X							

III. PROVIDER EDUCATION

Requirement Number	Requirements	Responsibility (“X” indicates the columns that apply)								
		F I	R H I	C a r r i e r	D M E R C	Shared System Maintainers				Other
F I S S	M C S					V M S	C W F			
3871.3	A provider education article related to this instruction will be available at www.cms.hhs.gov/medlearn/matters shortly after the CR is released. You will receive notification of the article release via the established "medlearn matters" listserv. Contractors shall post this article, or a direct link to this article, on their Web site and include information about it in a listserv message within 1 week of the availability of the provider education article. In addition, the provider education article shall be included in your next regularly scheduled bulletin and incorporated into any educational events on this topic. Contractors are free to supplement Medlearn Matters articles with localized information that would benefit their provider community in billing and administering the Medicare program correctly.	X	X			X				

IV. SUPPORTING INFORMATION AND POSSIBLE DESIGN CONSIDERATIONS

A. Other Instructions: N/A

X-Ref Requirement #	Instructions

B. Design Considerations: N/A

X-Ref Requirement #	Recommendation for Medicare System Requirements

C. Interfaces: OPPS OCE/ PRICER

D. Contractor Financial Reporting /Workload Impact:

E. Dependencies: N/A

F. Testing Considerations: N/A

V. SCHEDULE, CONTACTS, AND FUNDING

<p>Effective Date*: July1, 2005</p> <p>Implementation Date: July 5, 2005</p> <p>Pre-Implementation Contact(s): For OCE related issues contact: Diana Motsiopoulos at diana.motsiopoulos@cms.hhs.gov. or Antoinette Johnson at antoinette.johnson@cms.hhs.gov</p> <p>For Policy related issues contact: marina.kushnirova@cms.hhs.gov</p> <p>Post-Implementation Contact(s): Regional Office</p>	<p>No additional funding will be provided by CMS; Contractor activities are to be carried out within their FY 2005 operating budgets.</p>
---	--

*Unless otherwise specified, the effective date is the date of service.

ATTACHMENT A

(Rev. 572, Issued: 06-01-05, Effective: 07-01-05, Implementation: 07-05-05)

July Outpatient Code Editor (OCE) Specifications Version (V6.2)

This attachment contains specifications issued for the April OCE (Version 6.1). All shaded material reflects changes incorporated into the July version of the OPSS OCE (Version 6.2).

Introduction

This attachment provides OCE instructions and specifications that will be utilized under the OPSS for hospital outpatient departments, community mental health centers (CMHCs), and for limited services as defined below when provided in a comprehensive outpatient rehabilitation facility (CORF), home health agency (HHA) not under Home Health PPS or to a hospice patient for the treatment of a non-terminal illness. Henceforth, this OCE will be referred to as the OPSS OCE. You are required, effective with unprocessed claims with dates of service on or after August 1, 2000, to send the following bills through the OPSS OCE:

- All outpatient hospital Part B bills (bill types 12X, 13X, or 14X) with the exception of critical access hospitals (CAHs), Indian Health Service Hospitals (IHS)/ Tribal hospitals including HIS/ Tribal CAHs, Maryland hospitals, and hospitals located in American Samoa, Guam, and Saipan. In addition, claims from Virgin Island hospitals with dates of service January 1, 2002, and later, and claims from hospitals that furnish only inpatient Part B services with dates of service January 1, 2002, and later should not be sent through the OPSS OCE since they are also excluded from OPSS. (See below for more detail regarding these hospitals.);
- CMHC bills (bill type 76X);
- HHA and CORF bills containing certain Healthcare Common Procedure Coding System (HCPCS) codes as identified in the chart entitled “HCPCS Codes for Reporting Antigens, Hepatitis B Vaccines, Splints and Casts” below (bill types 34X or 75X); and
- Any bill containing a condition code 07, “treatment of non-terminal illness – hospice”, with certain HCPCS codes as identified in the chart entitled “HCPCS Codes for Reporting Antigens, Hepatitis B Vaccines, Splints and Casts” below.

Send all other outpatient bill types (22X, 23X, 24X, 32X, 33X, 43X, 71X, 72X, 73X, 74X, 81X or 82X) through the OPSS OCE. Send Indian Health Service hospitals, CAHs, Maryland hospitals, and hospitals located in American Samoa, Guam, and Saipan through the non-OPSS OCE (original OCE). Also send claims from Virgin Island hospitals with dates of service on or after January 1, 2002, and claims from hospitals that furnish only inpatient Part B services with dates of service on or after January 1, 2002, through the non-OPSS OCE. Refer to the IOM Chapter 100-04, Chapter 4, Section 150, for information regarding hospitals that provide Part B only services to their inpatients.

NOTE: For bill type 34X, only Hepatitis B vaccines and their administration, splints, casts, and antigens will be paid under OPSS. For bill type 75X, only Hepatitis B vaccines and their administration are paid under OPSS. For bills containing condition code 07, only splints, casts and antigens will be paid under OPSS.

You are also required to notify your providers of the OPSS OCE claim outputs.

The following information provides you with the OPSS OCE edit specifications that will be utilized to make appropriate payments under the OPSS system, which was effective August 1, 2000.

General Functions of the OCEs

The OPSS OCE performs the following two major functions:

- Edit claims data to identify errors and return a series of edit flags; and
- Assign an ambulatory payment classification (APC) number for each service covered under OPSS and return information to be used as input to the PRICER program.

A major change in processing was required to handle claims with service dates that span more than 1 calendar day. Each claim is represented by a collection of data, which consists of all necessary demographic (header) data, plus all services provided (line items). You are responsible for organizing all applicable services into a single claim record, and passing them as a unit to the OPSS OCE. OPSS OCE functions only on a single claim and does not have any cross-claim capabilities. OPSS OCE will accept up to 450 line items per claim. The OPSS OCE software is responsible for ordering line items by date of service.

The non-OPSS OCE focused solely on the presence or absence of specific edits and did not specify action that should be taken when an edit occurred (e.g., deny claim, suspend claim). Further, it did not compute any information that would be used for payment purposes. Therefore, it was structured to return a set of flags for each diagnosis and procedure that indicated the presence or absence of individual edits. The OPSS OCE not only identifies individual errors but also indicates actions to take and the reasons why these actions are necessary. In order to accommodate this expanded functionality, the OPSS OCE is structured to return lists of edit numbers instead of zero/one flags. This new structure facilitates the linkage between the action being taken, the reasons for the action, and the information on the claim (e.g., a specific diagnosis) that caused the action.

In general, the OPSS OCE performs all functions that require specific reference to HCPCS codes, HCPCS modifiers, and ICD-9-CM diagnosis codes. Since these coding systems are complex and annually updated, the centralization of the direct reference to these codes and modifiers in a single program will reduce effort for you and reduce the chance of inconsistent processing.

The span of time that a claim represents will be controlled by the from and through dates that will be part of the input header information. If the claim spans more than 1 calendar day, the OPSS OCE will subdivide the claim into separate days for the purpose of determining discounting and multiple visits on the same calendar day.

Some edits will be date driven. For example, bilateral procedures will be considered an error if a pair of procedures is coded with the same service date, but not if the service dates are different.

Information Sent to OPSS OCE

Header and line item information is passed to the OPSS OCE by means of a control block of pointers. Table 1 contains the structure of the "OPSS OCE Control Block". The shaded area separates input from return information. Multiple items are assumed to be in contiguous locations.

The header information must relate to the entire claim and must include the following:

- From date;
- Through date;
- Condition code;
- List of ICD-9-CM diagnosis codes;

- Age;
- Sex;
- Type of bill; and
- Medicare provider number.

The from and through dates will be used to determine if the claim spans more than 1 day and therefore represents multiple visits. The condition code (e.g., 41) specifies special claim conditions such as a claim for partial hospitalization, which is paid on a per diem basis. The diagnosis codes apply to the entire claim and are not specific to a line item. Each line item contains the following information:

- HCPCS code with up to 2 modifiers;
- Revenue code;
- Service date;
- Service units; and
- Charge.

The HCPCS codes and modifiers are used as the basis of assigning the APCs. Not all line items will contain a HCPCS code. The line item service dates are used to subdivide a claim that spans more than 1 day into individual visits. The service units indicate the number of times a HCPCS code was provided (e.g., a lab test with a service unit of 2 means the lab test was performed twice).

Information Returned From OPSS OCE

The following is an overview of the information that will be returned from OPSS OCE and used as input into the PRICER program.

Field	UB-92 Form Locator	Number	Size (bytes)	Comments
HCPCS procedure code	44	1	5	May be blank
HCPCS modifier	44	5 x 2	10	
Service date	45	1	8	Required for all lines
Revenue code	42	1	4	
Service units	46	1	7	A blank or zero value is defaulted to 1
Charge	47	1	10	Used by Pricer to determine outlier payments

Line item input information

There are currently 73 different edits in the OCE, two of which are currently inactive. Each edit is assigned a number. A description of the edits is contained in the “Claim Return Buffer” Table 4. The edit return buffers consist of a list of the edit numbers that occurred for each diagnosis, procedure, modifier, date, and or revenue code. For example, if a 75-year-old male had a diagnosis related to pregnancy it would create a conflict between the diagnosis and age and sex. Therefore, the diagnosis edit return buffer for the pregnancy diagnosis would contain the edit numbers 2 and 3. There is more space allocated in the edit return buffers than is necessary for the current edits in order to allow future expansion of the number of edits. Table 3 describes the Edit Return Buffers.

The “Claim Return Buffer” described in the Table 4 summarizes the edits that occurred on the claim. The occurrence of an edit can result in one of six different dispositions.

Claim Rejection	There are one or more edits present that cause the whole claim to be rejected. A claim rejection means that the provider can correct and resubmit the claim but cannot appeal the claim rejection.
Claim Denial	There are one or more edits present that cause the whole claim to be denied. A claim denial means that the provider cannot resubmit the claim but can appeal the claim denial.
Claim Return to Provider (RTP)	There are one or more edits present that cause the whole claim to be returned to the provider. A claim returned to the provider means that the provider can resubmit the claim once the problems are corrected.
Claim Suspension	There are one or more edits present that cause the whole claim to be suspended. A claim suspension means that the claim is not returned to the provider, but is not processed for payment until the FI makes a determination or obtains further information.
Line Item Rejection	There are one or more edits present that cause one or more individual line items to be rejected. A line item rejection means that the claim can be processed for payment with some line items rejected for payment. The line item can be corrected and resubmitted but cannot be appealed.
Line Item Denials	There are one or more edits present that cause one or more individual line items to be denied. A line item denial means that the claim can be processed for payment with some line items denied for payment. The line item can not be resubmitted but can be appealed.

In the OPSS OCE, many of the edits had a disposition of RTP in order to give providers time to adapt to OPSS. In subsequent releases of OPSS OCE, the disposition of some edits was changed to other more automatic dispositions such as a line item denial. A single claim can have one or more edits in all six dispositions. Six 0/1 dispositions are contained in the claim return buffer that indicate the presence or absence of edits in each of the six dispositions. In addition, there are six lists of reasons in the claim return buffer that contain the edit numbers that are associated with each disposition. For example, if there were three edits that caused the claim to have a disposition of RTP, the edit numbers of the three edits would be contained in the claim RTP reason list. There is more space allocated in the edit return buffers than is necessary for the current edits in order to allow for future expansion of the number of edits.

In addition to the six individual dispositions, there is also an overall claim disposition, which summarizes the status of the claim.

Table 5 describes the “APC Return Buffer” that contains the APC for each line item along with the relevant information for computing OPSS payment. Two APC numbers are returned: HCPCS APC and payment APC.

Except for partial hospitalization and some inpatient-only procedure claims, the HCPCS APC and the payment APC are always the same. The APC return buffer contains the information that will be passed to the Pricer. The APC is only returned for HOPDs and the special conditions specified in Appendix F.

Partial hospitalizations are paid on a per diem basis. There is no HCPCS code that specifies a partial hospitalization related service. Partial hospitalizations are identified by means of condition codes; bill types and HCPCS codes specifying the individual services that constitute a partial hospitalization (See Appendix C). Thus, there are no input line items that directly correspond to the partial hospitalization service. In order to assign the partial hospitalization APC to one of the line items, the payment APC for one of the line items that represent one of the services that comprise partial hospitalization is assigned the partial hospitalization APC.

Reimbursement for a day of outpatient mental health services in a non-PH program is capped at the amount of the partial hospital per diem. On a non-PHP claim, the OCE totals the payments for all MH services with the same date of service; if the sum of the payments for the individual MH services exceeds the partial hospital per-diem, the OCE assigns a special “Daily Mental Health Service” payment APC to one of the line items that represent MH services. The packaging flag is turned on for all other MH services for that day (See appendix

C). The payment rate for the Daily Mental Health Services APC is the same as that for the partial hospitalization APC.

For outpatients who undergo inpatient-only procedures on an emergency basis and who expire before they can be admitted to the hospital, a specified APC payment is made to the provider as reimbursement for all services on that day. The presence of modifier –CA on the inpatient-only procedure line assigns the specified payment APC and associated status and payment indicator to the line. The packaging flag is turned on for all other lines on that day. Payment is only allowed for one procedure with modifier -CA. If multiple inpatient-only procedures are submitted with the modifier –CA, the claim is returned to the provider. If modifier CA is submitted with an inpatient-only procedure for a patient who did not expire (patient status code is not 20), the claim is returned to the provider.

Inpatient-only procedures that are on the separate-procedure list (do not generate edit 18) are bypassed when performed incidental to a surgical procedure with Status Indicator T. The line(s) with the inpatient-separate procedure is rejected and the claim is processed according to usual OPSS rules.

When multiple occurrences of any APC that represents drug administration are assigned in a single day, modifier-59 is required on the code(s) in order to permit payment for additional units of that APC, up to a specified maximum; additional units above the maximum are packaged. If modifier –59 is not used, only one occurrence of any drug administration APC is allowed and any additional units are packaged (see Appendix I).

The use of a device is necessary to the performance of certain outpatient procedures. If any of these procedures is submitted without a code for the required device, the claim is returned to the provider. Discontinued procedures are not returned for a device code.

Observations may be paid separately if they meet specific criteria (See Appendix H).

In some circumstances, in order for Medicare to correctly allocate payment for blood processing and storage, providers are required to submit two lines with different revenue codes for the same service when blood products are billed. One line is required with revenue code 39X and an identical line (same HCPCS, modifier and units) with revenue code 38X (see Appendix J).

Not all edits are performed for all sites of service. See “OPSS OCE Edits Applied by Bill Type” below for OPSS OCE edits that apply for each bill type.

OPSS PRICER computes the standard OPSS payment for a line item as the product of the payment amount corresponding to the assigned payment APC, the discounting factor, and the number of units for all line items for which the following is true:

Criteria for Applying Standard OPSS Payment Calculations

- APC value is not 00000
- Payment indicator has a value of 1
- Packaging flag has a value of zero or 3
- Line item denial or rejection flag is zero or the line item action flag is 1
- Line item action flag is not 2, 3 or 4
- Payment adjustment flag is zero
- Payment method flag is zero

If payment adjustments are applicable to a line item (payment adjustment flag is not 0), then nonstandard calculations are necessary to compute payment for a line item (see Appendix E). The line item action flag is passed as input to the OPSS OCE as a means of allowing you to override a line item denial or rejection (used by you to override OPSS OCE and have OPSS PRICER compute payment ignoring the line item rejection or denial) or allowing you to indicate that the line item should be denied or rejected even if there are no OPSS

OCE edits present. The action flag is also used for handling external line item adjustments. For some sites of service (e.g., HHAs) only some services are paid under OPSS. The line item action flag also impacts the computation of the discounting factor as described in Appendix D “Computation of Discounting Fraction”. OPSS payment for the claim is computed as the sum of the payments for each line item with the appropriate conversion factor, wage rate adjustment, outlier adjustment, etc., applied. Appendix K summarizes the process of filling in the APC return buffer.

If a claim spans more than 1 day, OPSS OCE subdivides the claim into separate days for the purpose of determining discounting and multiple visits on the same day. Multiple day claims are determined based on calendar day. The OPSS OCE deals with all multiple day claims issues by means of the return information. OPSS PRICER does not need to be aware of the issues associated with multiple day claims. It simply applies the payment computation as described above and the result is the total OPSS payment for the claim regardless of whether the claim was for a single day or multiple days. If a multiple day claim has a subset of the days with a claim denial, RTP, or suspend, the whole claim is denied, RTP, or suspended.

For the purpose of determining the version of the OPSS OCE to be applied, the from date on the header information is used.

Tables

Table 1: OPSS OCE Control Block

Pointer Name		UB-92 Form Locator	Number	Size (bytes)	Comment
Dxptr	ICD-9-CM diagnosis codes	76 (adx) 67-75 (pdx/sdx)	Up to 16	6	Diagnosis codes apply to whole claim and are not specific to a line item (left justified, blank filled). First listed diagnosis is considered 'admit dx', second diagnosis is considered 'principal dx'
Ndxptr	Count of the number of diagnoses pointed to by <i>Dxptr</i>		1	4	Binary fullword count
Sgptr	Line item entries	44-46	Up to 450	Table 2	
Nsgptr	Count of the number of Line item entries pointed to by <i>Sgptr</i>		1	4	Binary fullword count
Flagptr	Line item action flag Flag set by FI and passed by OCE to Pricer		Up to 450	1	(See Table 7)
Ageptr	Numeric age in years		1	3	0-124
Sexptr	Numeric sex code	15	1	1	0, 1, 2 (unknown, male, female)
Dateptr	From and Through dates (yyyymmdd)	6	2	8	Used to determine multi-day claim
CCptr	Condition codes	24-30	Up to 7	2	Used to identify partial hospitalization and hospice claims
NCCptr	Count of the number of condition codes entered		1	4	Binary fullword count
Billptr	Type of bill	4	1	3	Used to identify CMHC and claims pending under OPSS. It is presumed that bill type has been edited for validity by the Standard System before the claim is sent to OCE
NPIProvptr	National provider identifier (NPI)	51	1	13	Pass on to Pricer
OSCARProvptr	OSCAR Medicare provider number	51	1	6	Pass on to Pricer
PstatPtr	Patient status	22	1	2	UB-92 values
OppsPtr	Opps/Non-OPSS flag		1	1	1=OPSS, 2=Non-OPSS (For future use)

OccPtr	Occurrence codes	36	Up to 10	2	For FI use
NOccptr	Count of number of occurrence codes		1	4	Binary fullword count
Dxeditptr	Diagnosis edit return buffer		Up to 16	Table 3	Count specified in Ndxptr
Proceditptr	Procedure edit return buffer		Up to 450	Table 3	Count specified in Nsgptr
Meditptr	Modifier edit return buffer		Up to 450	Table 3	Count specified in Nsgptr
Dteditptr	Date edit return buffer		Up to 450	Table 3	Count specified in Nsgptr
Rcreditptr	Revenue code edit return buffer		Up to 450	Table 3	Count specified in Nsgptr
APCptr	APC return buffer		Up to 450	Table 7	Count specified in Nsgptr
Claimptr	Claim return buffer		1	Table 5	
Wkptr	Work area pointer		1	256K	Working storage allocated in user interface
Wklenptr	Actual length of the work area pointed to by Wkptr		1	4	Binary fullword

For those using X12N 837 formats, the following is provided to assist in your implementation efforts:

The Medicare A 837 Health Care Claim version 4010 implementations 3A.01 and 1A.C1 (Appendix C of both documents have UB-92 mapping), along with the UB-92 version 6.0 are at www.hcfa.gov/medicare/edi/edi3.htm. These formats are effective through October 16, 2003. The X12N 837 version 4010 to UB-92 version 6.0 mapping is at <http://cms.hhs.gov/providers/edi/hipaadoc.asp>. The HIPAA X12N 837 can be downloaded at www.wpc-edi.com.

Table 2: Edit Return Buffers

Name	Bytes	Number	Values	Description	Comments
Diagnosis edit return buffer	2	8	0,1-5	Two-digit code specifying the edits that applied to the diagnosis.	There is one 8x2 buffer for each of up to 16 diagnoses.
Procedure edit return buffer	2	30	0,6,8-9,11-21, 28,37-40, 42-45,47, 49-50,52-64, 66-73	Two-digit code specifying the edits that applied to the procedure.	There is one 30x2 buffer for each of up to 450 line items.
Modifier edit return buffer	2	4	0,22	Two-digit code specifying the edits that applied to the modifier.	There is one 4x2 buffer for each of the five modifiers for each of up to 450 line items.
Date edit return buffer	2	4	0,23	Two-digit code specifying the edits that applied to <u>line item</u> dates.	There is one 4x2 buffer for each of up to 450 line items.
Revenue center edit return buffer	2	5	0, 41,48, 65	Two-digit code specifying the edits that applied to revenue centers.	There is one 5x2 buffer for each of up to 450 line items

Each of the return buffers is positionally representative of the source that it contains information for, in the order in which that source was passed to OPSS OCE. For example, the seventh diagnosis return buffer contains information about the seventh diagnosis; the fourth modifier edit buffer contains information about the modifiers in the fourth line item.

Table 3: Description of Edits/Claim Reasons

Edit	Description	Disposition
1	Invalid diagnosis code	RTP
2	Diagnosis and age conflict	RTP
3	Diagnosis and sex conflict	RTP
4 ⁴	Medicare secondary payor alert (V1.0 and V1.1 only)	Suspend
5 ⁴	E-diagnosis code can not be used as principal diagnosis	RTP
6	Invalid procedure code	RTP
7	Procedure and age conflict (Not activated)	RTP
8	Procedure and sex conflict	RTP
9	Non-covered for reasons other than statute	Line item denial
10	Service submitted for verification of denial (condition code 21)	Claim denial
11	Service submitted for FI review (condition code 20)	Suspend
12	Questionable covered service	Suspend
13	Separate payment for services is not provided by Medicare	Line Item Rejection
14	Code indicates a site of service not included in OPPTS	Claim RTP
15	Service unit out of range for procedure ¹	RTP
16	Multiple bilateral procedures without modifier 50 (see Appendix A)	RTP
17	Inappropriate specification of bilateral procedure (see Appendix A)	RTP
18	Inpatient procedure ²	Line item denial
19	Mutually exclusive procedure that is not allowed by NCCI even if appropriate modifier is present	Line item rejection
20	Code2 of a code pair that is not allowed by NCCI even if appropriate modifier is present	Line item rejection
21	Medical visit on same day as a type "T" or "S" procedure without modifier 25 (see Appendix B)	Line item rejection
22	Invalid modifier	RTP
23	Invalid date	RTP
24	Date out of OCE range	Suspend
25	Invalid age	RTP
26	Invalid sex	RTP
27	Only incidental services reported ³	Claim Denial
28	Code not recognized by Medicare; alternate code for same service may be available (see Appendix C for logic of edits 29-36, and 63-64)	Line item Rejection
29	Partial hospitalization service for non-mental health diagnosis	RTP
30	Insufficient services on day of partial hospitalization	Suspend
31	Partial hospitalization on same day as ECT or type T procedure	Suspend
32	Partial hospitalization claim spans 3 or less days with insufficient services, or ECT or significant procedure on at least one of the days	Suspend
33	Partial hospitalization claim spans more than 3 days with insufficient number of days having mental health services	Suspend
34	Partial hospitalization claim spans more than 3 days with insufficient number of days meeting partial hospitalization criteria	Suspend
35	Only Mental Health education and training services provided	RTP
36	Extensive mental health services provided on day of ECT or type T procedure	Suspend
37	Terminated bilateral procedure or terminated procedure with units greater than one	RTP
38	Inconsistency between implanted device and implantation procedure	RTP
39	Mutually exclusive procedure that would be allowed by NCCI if appropriate modifier were present	Line item rejection
40	Code2 of a code pair that would be allowed by NCCI if appropriate modifier were present	Line item rejection
41	Invalid revenue code	RTP
42	Multiple medical visits on same day with same revenue code without condition code G0 (see Appendix B)	RTP
43	Transfusion or blood product exchange without specification of blood product	RTP
44	Observation revenue code on line item with non-observation HCPCS code	RTP
45	Inpatient separate procedures not paid	Line item rejection
46	Partial hospitalization condition code 41 not approved for type of bill	RTP
47	Service is not separately payable	Line item rejection
48	Revenue center requires HCPCS	RTP
49	Service on same day as inpatient procedure	Line item denial
50	Non-covered based on statutory exclusion	Line item rejection
51	Multiple observations overlap in time (Not activated)	RTP

52	Observation does not meet minimum hours, qualifying diagnoses, and/or 'T' procedure conditions	RTP
53	Observation G codes only allowed with bill type 13x	Line item rejection
54	Multiple codes for the same service	RTP
55	Non-reportable for site of service	RTP
56	E/M-condition not met and line item date for obs code G0244 is not 12/31 or 1/1	RTP
57	E/M condition not met and line item date for obs code G0244 is 12/31 or 1/1	Suspend
58	G0263 only allowed with payable G0244	RTP
59	Clinical trial requires diagnosis code V707 as other than primary diagnosis	RTP
60	Use of modifier CA with more than one procedure not allowed	RTP
61	Service can only be billed to the DMERC	RTP
62	Code not recognized by OPPTS; alternate code for same service may be available	RTP
63	This OT code only billed on partial hospitalization claims (See appendix C)	RTP
64	AT service not payable outside the partial hospitalization program (See appendix C)	Line item rejection
65	Revenue code not recognized by Medicare	Line item rejection
66	Code requires manual pricing	Suspend
67	Service provided prior to FDA approval	Line item rejection
68	Service provided prior to date of National Coverage Determination (NCD) approval	Line item rejection
69	Service provided outside approval period	Line item rejection
70	CA modifier requires patient status code 20	RTP
71	Claim lacks required device code	RTP
72	Service not billable to the Fiscal Intermediary	RTP
73	Incorrect billing of blood and blood products	RTP

- 1 For Edit 15, units for all line items with same HCPCS on the same day are added together for the purposes of applying the edit. If the total units exceed the code's limits, the procedure edit return buffer is set for all line items that have the HCPCS code. If modifier 91 is present on a line and the HCPCS is on a list of codes that are exempt, the unit edits are not applied.
- 2 Edit 18 will cause all other line items on the same day to be line item denied with Edit 49 (see Table 5 "Line item denial or reject flag".) No other edits are performed on any lines with Edit 18 or 49.
- 3 If Edit 27 is triggered, no other edits are performed on the claim.
- 4 Not applicable for admitting diagnosis.
- 5 Edits 67 & 68 are intended to line item reject any line that has a line item date of service that precedes the effective date of FDA approval (MMA 621 (a) (1) (15) OR the effective date of a National Coverage Determination (NCD) (MMA 731). If the service is provided prior to the effective date of FDA approval or prior to the effective date of a NCD, then the service is considered not covered by Medicare. Edits 67 & 68 were established to comply with MMA.

Table 4: Claim Return Buffer

	Bytes	Number	Values	Description
Claim processed flag	1	1	0-3, 9	0 - Claim processed. 1 - Claim could not be processed (edits 23, 24, or 46 ^a). 2 - Claim could not be processed (claim has no line items). 3 - Claim could not be processed (edit 10 - condition code 21 is present). 9 - Fatal error; OCE can not run - the environment can not be set up as needed; exit immediately.
Num of line items	3	1	nnn	Input value from Nsgptr, or 450, whichever is less.
National provider identifier (NPI)	13	1	aaaaaaaa aaaaaaaa	Transferred from input, for Pricer.
OSCAR Medicare provider number	6	1	aaaaaa	Transferred from input, for Pricer.
Overall claim disposition	1	1	0-5	0 - No edits present on claim. 1 - Only edits present are for line item denial or rejection. 2 - Multiple-day claim with one or more days denied or rejected. 3 - Claim denied, rejected, suspended or returned to provider, or single day claim w all line items denied or rejected, w only post payment edits.

				4 - Claim denied, rejected, suspended or returned to provider, or single day claim w all line items denied or rejected, w only pre-payment edits. 5 - Claim denied, rejected, suspended or returned to provider, or single day claim w all line items denied or rejected, w both post-payment and pre-payment edits.
Claim rejection disposition	1	1	0-2	0 - Claim not rejected. 1 - There are one or more edits present that cause the claim to be rejected. 2 - There are one or more edits present that cause one or more days of a multiple-day claim to be rejected.
Claim denial disposition	1	1	0-2	0 - Claim not denied. 1 - There are one or more edits present that cause the claim to be denied. 2 - There are one or more edits present that cause one or more days of a multiple-day claim to be denied, or single day claim with all lines denied (edit 18 only).
Claim returned to provider disposition	1	1	0-1	0 - Claim not returned to provider. 1 - There are one or more edits present that cause the claim to be returned to provider.
Claim suspension disposition	1	1	0-1	0 - Claim not suspended. 1 - There are one or more edits present that cause the claim to be suspended.
Line item rejection disposition	1	1	0-1	0 - There are no line item rejections. 1 - There are one or more edits present that cause one or more line items to be rejected.
Line item denial disposition	1	1	0-1	0 - There are no line item denials. 1 - There are one or more edits present that cause one or more line items to be denied.
Claim rejection reasons	2	4		Two digit code specifying edits (See Table 6) that caused the claim to be rejected. There are currently no edits that cause a claim to be rejected.
Claim denial reasons	2	8	10, 27	Two digit code specifying edits (see Table 6) that caused the claim to be denied. There are currently two active edits that cause a claim to be denied.
Claim returned to provider reasons	2	30	1-3, 5-6, 8, 14-17, 22-23, 25-26, 29, 35, 37-38, 41-44, 46, 48, 52, 54, 55,56, 58-63, 70-73	Two-digit code specifying edits (see Table 6) that caused the claim to be returned to provider. There are currently 38 active edits that cause a claim to be returned to provider.
Claim suspension reasons	2	16	4, 11, 12, 24, 30-34, 36, 57, 66	Two-digit code specifying the edits that caused the claim to be suspended (see Table 6). There are currently 12 active edits that cause a claim to be suspended.
Line item rejection reasons	2	12	13, 19, 20, 21, 28, 39, 40, 45, 47, 50, 53, 64, 65, 67-69	Two digit code specifying the edits that caused the line item to be rejected (See Table 6). There are currently 16 active edits that cause a line item to be rejected.
Line item denied reasons	2	6	9, 18, 49	Two-digit code specifying the edits that caused the line item to be denied (see Table 6). There are currently 3 active edits that cause a line item denial.
APC return	1	1	0-1	0 - No services paid under OPSS. APC return buffer filled in with default

buffer flag				values (See AppxF). 1 - One or more services paid under OPPS. APC return buffer filled in.
VersionUsed	8	1	yy.vv.r r	Version ID of the version used for processing the claim (e.g., 2.1.0).
Patient Status	2	1		Patient status code - transferred from input.
Opps Flag	1	1	1-2	OPPS/Non-OPPS flag - transferred from input.

^a Edit 46 terminates processing only for those bill types where no other edits are applied (See App. F).

Table 5: APC Return Buffer

Name	Size (bytes)	Values	Description
HCPCS procedure code	5	Alpha	For potential future use by Pricer. Transfer from input
Payment APC	5	00001-nnnnn	APC used to determine payment. If no APC assigned to line item, the value 00000 is assigned. For partial hospitalization and some inpatient-only procedure claims the payment APC may be different than the APC assigned to the HCPCS code.
HCPCS APC	5	00001-nnnnn	APC assigned to HCPCS code
Status indicator	1	Alpha	A - Services not paid under OPPS B - Non-allowed item or service for OPPS C - Inpatient procedure E - Non-allowed item or service F - Corneal tissue acquisition and certain CRNA services G - Drug/Biological Pass-through H - Device pass-through J - New drug or new biological pass-through ¹ K - Non pass-through drug / biological, radiopharmaceutical agent, certain brachytherapy sources L - Flu/PPV vaccines M - Service not billable to the FI N - Packaged incidental service P - Partial hospitalization service S - Significant procedure not subject to multiple procedure discounting T - Significant procedure subject to multiple procedure discounting V - Medical visit to clinic or emergency department W - Invalid HCPCS or Invalid revenue code with blank HCPCS X - Ancillary service Y - Non-implantable DME, Therapeutic Shoes Z - Valid revenue with blank HCPCS and no other SI assigned
Payment indicator	1	Alphanumeric	1 - Paid standard hospital OPPS amount (status indicators K, S, T, V, X) 2 - Services not paid under OPPS (status indicator A) 3 - Not paid (M, W, Y, E), or not paid under OPPS (B, C, Z) 4 - Paid at reasonable cost (status indicator F, L) 5 - Additional payment for drug or biological (status indicator G) 6 - Additional payment for device (status indicator H) 7 - Additional payment for new drug or new biological (status indicator J) 8 - Paid partial hospitalization per diem (status indicator P) 9 - No additional payment, payment included in line items with APCs (status indicator N, or no HCPCS code and certain revenue codes, or HCPCS codes G0176 (activity therapy), G0129 (occupational therapy), or G0177 (partial hospitalization program services))
Discounting formula number	1	1-8	See Appendix D for values
Line item denial or rejection flag	1	0-2	0 - Line item not denied or rejected 1 - Line item denied or rejected (edit return buffer for line item contains a 9, 13, 18, 19, 20, 21, 28, 39, 40, 45, 47, 49, 50, 53, 64, 65, 67, 68, 69) 2- The line is not denied or rejected, but occurs on a day that has been denied or rejected (not used as of 4/1/02 - v3.0).
Packaging flag	1	0-4	0 - Not packaged

			1 – Packaged service (status indicator N, or no HCPCS code and certain revenue codes) 2 – Packaged as part of partial hospital per diem or daily mental health service per diem 3 – Artificial charges for surgical procedure (submitted charges for surgical HCPCS < \$1.01) 4 – Packaged as part of drug administration APC payment
Payment adjustment flag	1	0-6	0 - No payment adjustment 1 – Additional payment for drug or biological applies to APC (status indicator G) 2 – Additional payment for device applies to APC (status indicator H) 3 – Additional payment for new drug or new biological applies to APC (status indicator J) ¹ 4 – Deductible not applicable (specific list of HCPCS codes) 5 – Blood/blood product used in blood deductible calculation 6 – Blood processing/storage not subject to blood deductible
Payment Method Flag	1	0-4	0 - OPSS Pricer determines payment for service 1 - Based on OPSS coverage or billing rules, the service is not paid 2 - Service is not subject to OPSS 3 - Service is not subject to OPSS, and has an OCE line item denial or rejection 4 - Line item is denied or rejected by FI; OCE not applied to line item
Service units	7	1-x	Transferred from input, for Pricer. For the line items assigned APCs 33 or 34, the service units are always assigned a value of one by the OCE even if the input service units were greater than one [Input service units also may be reduced for some Drug administration APCs, based on Appendix I]
Charge	10	nnnnnnnnnn	Transferred from input, for Pricer; COBOL pic 9(8)v99
Line item action flag	1	0-4	Transferred from input to Pricer, and can impact selection of discounting formula (AppxD). 0 - OCE line item denial or rejection is not ignored 1 - OCE line item denial or rejection is ignored 2 - External line item denial. Line item is denied even if no OCE edits 3 - External line item rejection. Line item is rejected even if no OCE edits 4 - External line item adjustment. Technical charge rules apply.

¹ Status indicator J was replaced by status indicator G starting in April 2002 (V3.0)

Table 6: HCPCS Codes for Reporting Antigens, Hepatitis B Vaccines, Splints, and Casts

List of HCPCS codes in the following chart specify Hepatitis B vaccines, antigens, splints, and casts, which were paid under OPSS for hospitals. In addition certain situations for HHAs and CORFs and to hospice patients for the treatment of a non-terminal illness.

Category	Code
Antigens	95144, 95145, 95146, 95147, 95148, 95149, 95165, 95170, 95180, 95199
Hepatitis B Vaccines	G0010, 90740, 90743, 90744, 90746, 90747
Splints	29105, 29125, 29126, 29130, 29131, 29505, 29515
Casts	29000, 29010, 29015, 29020, 29025, 29035, 29040, 29044, 29046, 29049, 29055, 29058, 29065, 29075, 29085, 29086, 29305, 29325, 29345, 29355, 29358, 29365, 29405, 29425, 29435, 29440, 29445, 29450, 29700, 29705, 29710, 29715, 29720, 29730, 29740, 29750, 29799

Changes in Payment of Influenza Virus and Pneumococcal Pneumonia Vaccine (PPV)

Effective for claims with dates of service on or after January 1, 2003, payment for influenza virus and PPV vaccines and their administration provided in a hospital outpatient department, home health agency (HHA), and comprehensive outpatient rehabilitation facility (CORF) will change. Payment will no longer be made based on the Outpatient Prospective Payment System (OPPS). Hospitals (bill type 13X), and HHAs (bill type 34X) will be paid based on reasonable cost for the vaccines and their administration. CORFs (bill type 75X) will be paid based on the lower of the charges or 95% of the average wholesale price (AWP) for the vaccine and on the Medicare Physician Fee Schedule for the administration.

A new Service Indicator (SI) of "L" (L = Paid reasonable cost or 95% of the AWP; not subject to deductible or coinsurance) has been assigned to influenza and PPV vaccines and their administration in the OPPS OCE. The applicable HCPCS codes are 90657, 90658, 90659, 90732, G0008, and G0009.

The Shared System Maintainer (SSM) is required upon receipt of the SI "L" from the OPPS OCE to make the appropriate payment determination (reasonable cost or AWP) based on the type of bill submitted.

NOTE: Payment to all other providers for vaccines will remain the same. In addition, payment for Hepatitis B vaccine provided in any setting will also remain the same.

Correct Coding Initiative (CCI) Edits

The OPPS OCE will generate CCI edits. All CCI edits will be incorporated in the OPPS OCE with the exception of anesthesiology, E&M, mental health, certain injections and certain drug administrative codes. In addition, CCI edits for computer-aided detection (CAD) devices were removed from the July 2003 version of the OPPS OCE. They have been re-installed in this release. Bypass modifiers and coding pairs in the OCE may differ from those in the NCCI because of differences between facility and professional services.

The CCI edits are applicable to claims submitted on behalf of the same beneficiary, provided by the same provider, and on the same date of service. The edits address two major types of coding situations. One type, referred to as the comprehensive/component edits, are those edits to code combinations where one of the codes is a component of the more comprehensive code. In this instance only the comprehensive code is paid. The other type, referred to as the mutually exclusive edits, are those edits applied to code combinations where one of the codes is considered to be either impossible or improbable to be performed with the other code. Other unacceptable code combinations are also included. One such code combination consists of one code that represents a service 'with' something and the other is 'without' the something. The edit is set to pay the lesser-priced service.

Version 11.1 of CCI edits is included in the April OPPS OCE.

NOTE: The CCI edits in the OPPS OCE are always one quarter behind the Carrier CCI edits.

See Appendix F "OPPS OCE Edits Applied by Bill Type" for bill types that the OPPS OCE will subject to these and other OPPS OCE edits.

Units of Service Edit

The OPPS OCE edit 15 "Service Unit Out of Range for Procedure" was revised for the April 2003 version of the OPPS OCE. As part of the recurring quarterly update of the OPPS OCE, CMS lifted the moratorium on application of the OPPS OCE Edit 15. Therefore, you were instructed to reactivate OPPS OCE Edit 15 for claims with dates of service on or after April 1, 2003. This unit of service edit is not applied to all services at this time. Instead, there are limited edits applied to certain services beginning with the April 2003 release. However subsequent modifications to this edit will be made in upcoming OPPS OCE releases.

Appendix A Bilateral Procedure Logic

There is a list of codes that are exclusively bilateral if a modifier of 50 is present. The following edits apply to these bilateral procedures.

Condition	Action	Edit
The same code which can be performed bilaterally occurs two or more times on the same date of service, all codes <i>without</i> a 50 modifier	Return claim to provider	16
The same code which can be performed bilaterally occurs two or more times (based on units and/or lines) on the same date of service, all or some codes <i>with</i> a 50 modifier	Return claim to provider	17

In addition, there is a list of codes that are considered inherently bilateral even if a modifier of 50 is not present. The following edits apply to these bilateral procedures.

Condition	Action	Edit
The same bilateral code occurs two or more times (based on units and/or lines) on the same date of service	Return claim to provider	17

Note: For ER and observation claims, all services on the claim are treated like any normal claim, including multiple day processing.

Appendix B

Rules for Medical and Procedure Visits on the Same Day and for Multiple Medical Visits on Same Day

Under some circumstances, medical visits on the same date as a procedure will result in additional payments. A modifier of **25** with an Evaluation and Management (E&M) code, status indicator V, is used to report a medical visit that takes place on the same date that a procedure with status indicator S or T is performed, but that is significant and separately identifiable from the procedure. However, if any E&M code that occurs on a day with a type “T” or “S” procedure does not have a modifier of 25, then edit 21 will apply and there will be a line item rejection.

If there are multiple E&M codes on the same day, on the same claim the rules associated with multiple medical visits are shown in the following table.

E&M Code	Revenue Center	Condition Code	Action	Edit
2 or more	Revenue center is different for each E&M code, and all E&M codes have units equal to 1.	Not G0	Assign medical APC to each line item with E&M code	-
2 or more	Two or more E&M codes have the same revenue center OR One or more E&M codes with units greater than one had same revenue center	Not G0	Assign medical APC to each line item with E&M code and Return Claim to Provider	42
2 or more	Two or more E&M codes have the same revenue center OR one or more E&M codes with units greater than one had same revenue center	G0	Assign medical APC to each line item with E&M code	-

The condition code G0 specifies that multiple medical visits occurred on the same day with the same revenue center, and that these visits were distinct and constituted independent visits (e.g., two visits to the ER for chest pain).

Appendix C Partial Hospitalization Logic

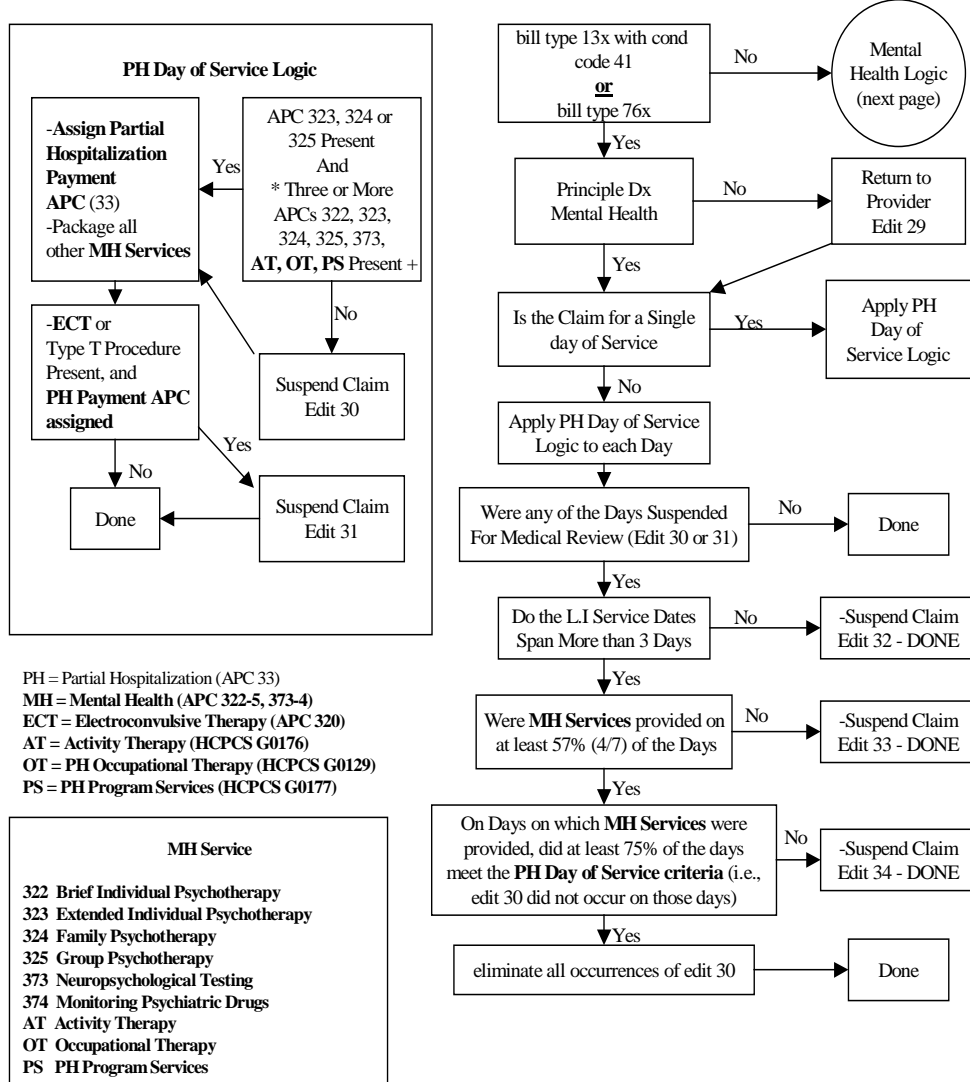

PH = Partial Hospitalization (APC 33)
 MH = Mental Health (APC 322-5, 373-4)
 ECT = Electroconvulsive Therapy (APC 320)
 AT = Activity Therapy (HCPCS G0176)
 OT = PH Occupational Therapy (HCPCS G0129)
 PS = PH Program Services (HCPCS G0177)

MH Service

322 Brief Individual Psychotherapy
 323 Extended Individual Psychotherapy
 324 Family Psychotherapy
 325 Group Psychotherapy
 373 Neuropsychological Testing
 374 Monitoring Psychiatric Drugs
 AT Activity Therapy
 OT Occupational Therapy
 PS PH Program Services

+ Multiple occurrences of APC 322, 323, 324, 325, and 373; AT and PS are treated as separate units in determining whether 3 or more MH services are present. However, multiple occurrences of OT are treated as a single service.

*To avoid confusion over this programming language, the OCE will continue to verify that the claim has, at a minimum, a total of 3 partial hospitalization HCPCS codes for each day of service, one of which must be a psychotherapy HCPCS that groups to APC 323, 324 or 325.

Assign Partial Hospitalization Payment APC

For any day that has an MH Service, the first listed line item with HCPCS APC from the hierarchical list of APCs (323, 324, 325, 322, 373, 374, AT, OT, PS) is assigned a payment APC of 33, a status indicator of P a payment indicator of 8, a discounting factor of 1, a line item denial or rejection indicator of 0, a packaging flag of 0, a payment adjustment flag of 0, and a service unit of 1

For all other line items with a **mental health service** (APC 322, 323, 324, 325, 373, 374, AT, OT, PS) the packaging flag is set to 2.

Appendix C (cont'd) Mental Health Logic

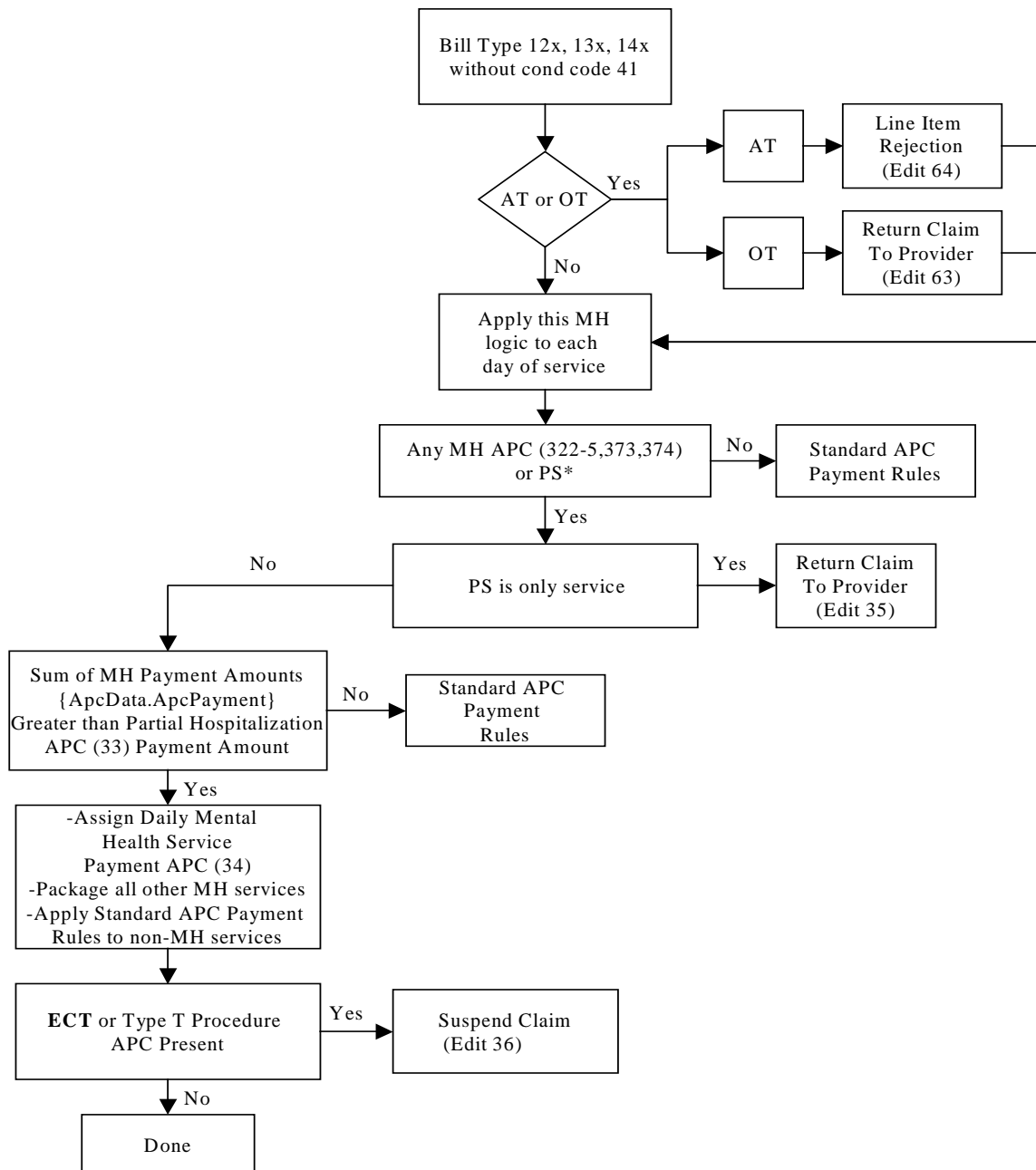

Assign Daily Mental Health Service Payment APC

The first listed line item with HCPCS APC from the list of MH APCs (322-5, 373, 374) is assigned a payment APC of 34, a status indicator of P, a payment indicator of 8, a discounting factor of 1, a line item denial or rejection indicator of 0, a packaging flag of 0, a payment adjustment flag of 0 and a service unit of 1.

For all other line items with a **mental health service** (APC 322-5, 373, 374, PS) the packaging flag is set to 2.

*NOTE: The use of code G0177 (PS) is allowed on MH claims that are not billed as Partial Hospitalization

Appendix D

Computation of Discounting Fraction

Line items with a status indicator of "T" are subject to multiple procedure discounting *unless modifiers 76,77,78 and/or 79 are present*. The "T" line item with the highest payment amount will *not* be multiple procedure discounted, and all other "T" line items will be multiple procedure discounted. All line items that do not have a status indicator of "T" will be ignored in determining the discount. A modifier of 73 indicates that a procedure was terminated prior to anesthesia. A terminated type "T" procedure will also be discounted although not necessarily at the same level as the discount for multiple type "T" procedures. Terminated bilateral procedures or terminated procedures with units greater than one for type "T" procedures should not occur, and have the discounting factor set so as to result in the equivalent of a single procedure. Bilateral procedures are identified from the "bilateral" field in the physician fee schedule. For non-type "T" procedures there is no terminated procedure or multiple bilateral discounting performed. Bilateral procedures have the following values in the "bilateral" field:

1. Conditional bilateral (i.e. procedure is considered bilateral if the modifier 50 is present)
2. Inherent bilateral (i.e. procedure in and of itself is bilateral)
3. Independent bilateral (i.e., procedure is considered bilateral if the modifier 50 is present, but full payment should be made for each procedure (e.g., certain radiological procedures))

Inherent bilateral procedures will be treated as a non-bilateral procedure since the bilateralism of the procedure is encompassed in the code. For bilateral procedures the type "T" procedure discounting rules will take precedence over the discounting specified in the physician fee schedule. All line items for which the line item denial or reject indicator is 1 and the line item action flag is zero, or the line item action flag is 2, 3 or 4, will be ignored in determining the discount; **packaged line items, (the packaging flag is not zero or 3), will also be ignored in determining the discount.** The discounting process will utilize an APC payment amount file. The discounting factor for bilateral procedures is the same as the discounting factor for multiple type "T" procedures.

There are eight different discount formulas that can be applied to a line item.

1. 1.0
2. $(1.0 + D(U-1))/U$
3. T/U
4. $(1 + D)/U$
5. D
6. TD/U
7. $D(1 + D)/U$
8. 2.0

Where

D = discounting fraction (currently 0.5)

U = number of units

T = terminated procedure discount (currently 0.5)

The discount formula that applies is summarized in the following table

Discounting Formula Number						
Payment Amount	Modifier 73	Modifier 50	Type "T" Procedure		Non Type "T" Procedure	
			Conditional or Independent Bilateral	Inherent or Non Bilateral	Conditional or Independent Bilateral	Inherent or Non Bilateral
Highest	No	No	2	2	1	1
Highest	Yes	No	3	3	1	1
Highest	No	Yes	4	2	8	1
Highest	Yes	Yes	3	3	8	1
Not Highest	No	No	5	5	1	1
Not Highest	Yes	No	6	6	1	1
Not Highest	No	Yes	7	5	8	1
Not Highest	Yes	Yes	6	6	8	1

For the purpose of determining which APC has the highest payment amount, the terminated procedure discount (**T**) will be applied prior to selecting the type T procedure with the highest payment amount.

Appendix F - OCE Edits Applied by Bill Type

Appendix F Flow Chart

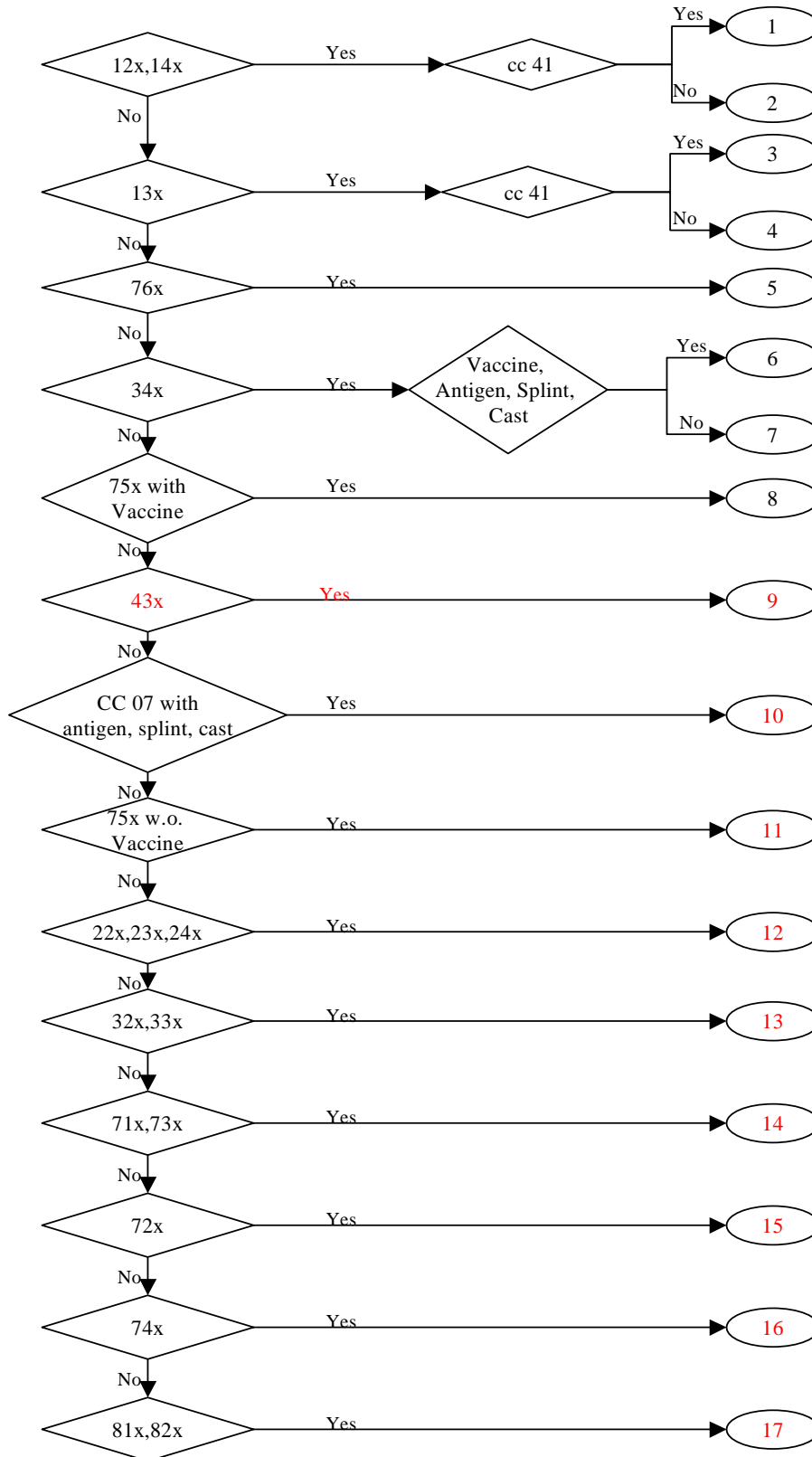

Appendix G

The payment adjustment flag for a line item (See Table 5) is set based on the criteria in the following chart:

Criteria	Payment Adjustment Flag Value
Status indicator G	1
Status indicator H	2
Status indicator J 1	3
Code is flagged as 'deductible not applicable'	4
Blood product with modifier BL on RC 38X line ²	5
Blood product with modifier BL on RC 39X line ²	6
All others	0

¹ Status indicator J was replaced by status indicator G starting in April 2002 (V3.0)

² See Appendix J for assignment logic (v6.2)

Appendix H OCE Observation Criteria

Assumptions

1. Separately payable observation is identified by code G0244.
2. Code G0244 has default Status indicator 'S', and default APC 339.
3. Observation logic is performed only for claims with bill type 13x, with or without condition code 41.
Lines with G0244, G0263 and G0264 are rejected if the bill type is not 13x.
4. If any of the observation criteria is not met, the claim is Returned to Provider or suspended, according to the disposition of the observation edits.
5. Each observation must be paired with a unique E/M or critical care (C/C) visit, or with code G0263 (Direct admission from physician's office).
E/M or C/C visit is required the day before or day of observation; direct admission is required on the day of observation.
If E/M is coded the same day as an S or T procedure (Observation G0244 has SI = S), it must have modifier 25 coded also. Otherwise, Edit 21 is generated for the E/M visit and it is ignored.
If an observation cannot be paired with an E/M or C/C visit or direct admission, the claim is returned to Provider.
6. E/M or C/C visit or direct admission on the same day as observation takes precedence over E/M or C/C visit on the day before observation.
7. E/M, C/C visit or direct admission that have been denied or rejected, either externally or by OCE edits, are ignored.
8. Both the associated E/M and C/C visit (APCs 600-602, 610-612, 620) and observation are paid separately if the observation criteria are met.
9. Multiple observations on a claim are paid separately if the required criteria are met for each one.
10. If there are multiple observations within the same time period and only one meets the criteria for APC payment, the observation with the most hours is considered to have met the criteria, and the other observations will cause the claim to be Returned to Provider.
11. Observation date is assumed to be the date admitted for observation.
12. The diagnoses (admitting or principal) required for the observation criteria are:

Chest Pain	Asthma	CHF
4110, 1, 81, 89	49301, 02, 11, 12, 21, 22, 91, 92	3918
4130, 1, 9		39891
78605, 50, 51, 52, 59		40201, 11, 91
		40401, 03, 11, 13, 91, 93
		4280, 1, 9, 20-23, 30-33, 40-43

13. The APCs required for the observation criteria to identify E/M or C/C visits are 600*-602, 610-612, 620.

*Except when APC 600 is assigned based on code G0264.

Appendix H OCE Observation Criteria (cont'd)

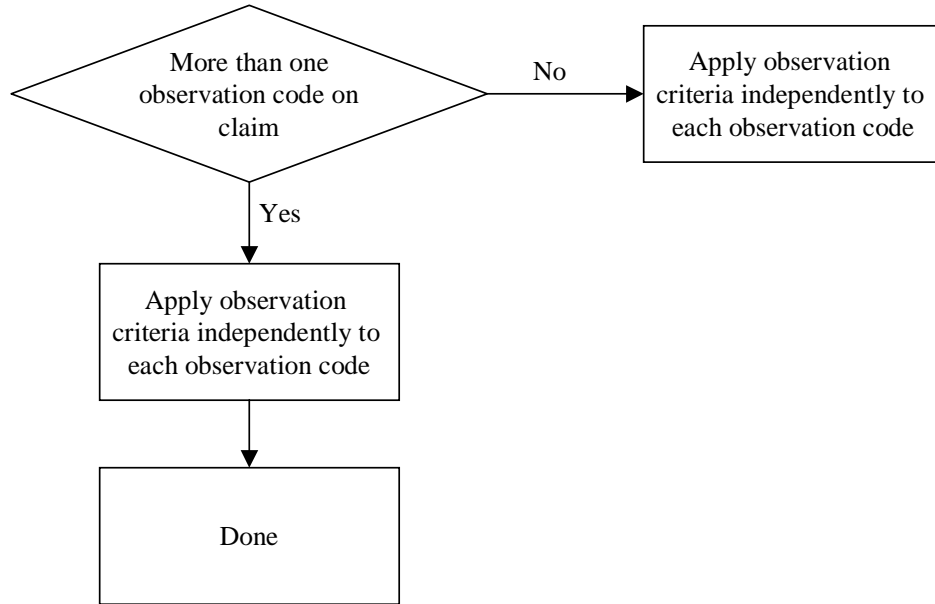

Appendix H OCE Observation Criteria (cont'd)

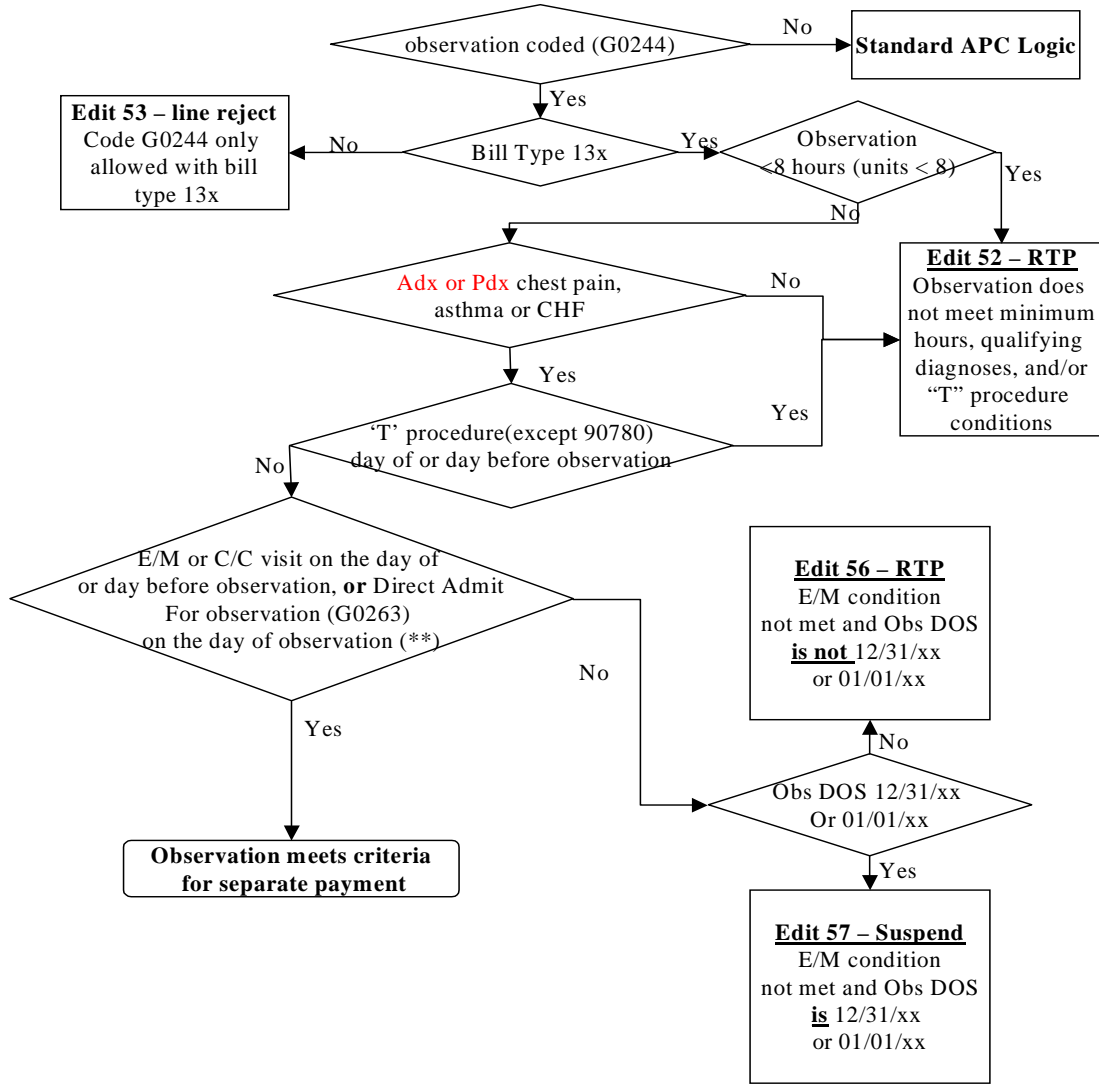

(**) E/M, C/C or Direct Admit that has not already been paired with another observation

Appendix I

Drug Administration

For each APC X subjected to Y maximum allowed units do the following (each day);

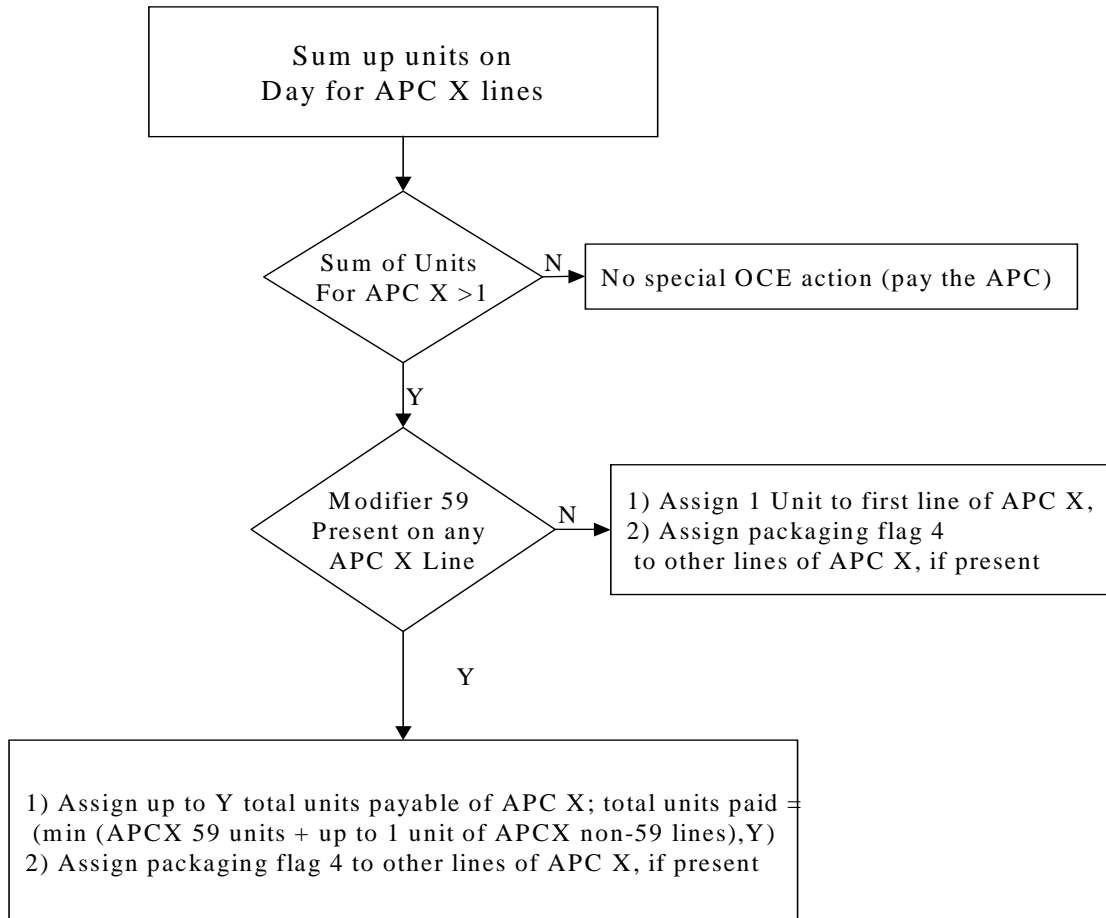

Appendix J

Billing for blood/blood products

For each HCPCS on the Blood Products List, do the following:

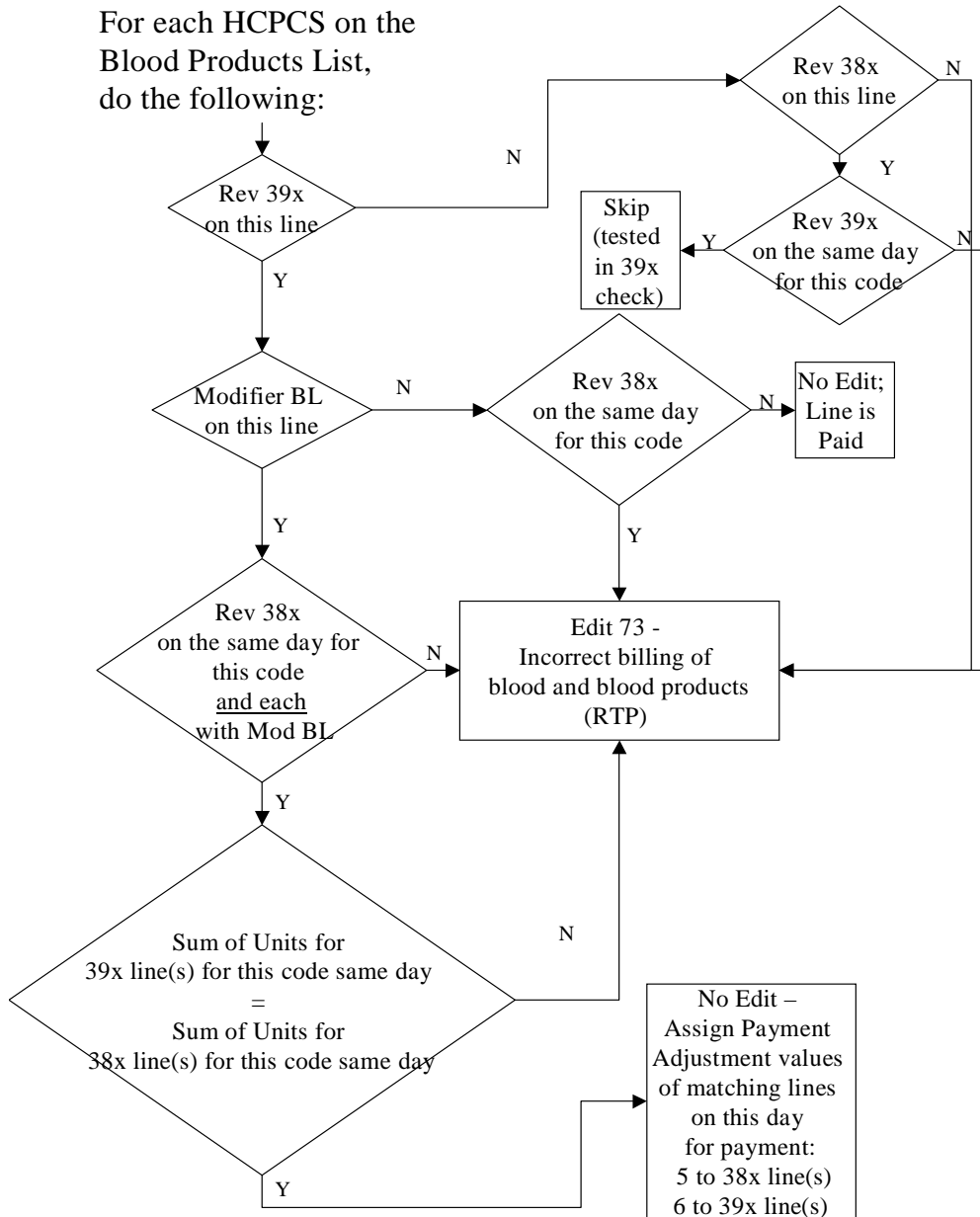

Appendix K OCE overview

1. If claim from/through dates span more than one day, subdivide the line items on the claim into separate days based on the calendar day of the line item service date.
2. Assign the default values to each line item in the APC return buffer.
The default values for the APC return buffer for variables not transferred from input are as follows:

Payment APC	00000
HCPCS APC	00000
Status indicator	A
Payment indicator	2
Discounting formula number	1
Line item denial or rejection flag	0
Packaging flag	0
Payment adjustment flag	0
Payment method flag	Assigned in steps 8, 17 and 18

3. If no HCPCS code is on a line item and the revenue code is from one of four specific lists, then assign the following values to the line item in the APC return buffer.

	N-list	E-list	B-list	F-list
HCPCS APC	00000	00000	00000	00000
Payment APC:	00000	00000	00000	00000
Status Indicator:	N	E	B	F
Payment Indicator	9	3	3	4
Packaging flag:	1	0	0	0

If there is no HCPCS code on a line, and the revenue center is not on any of the specified lists, assign default values as follows:

HCPCS APC	00000
Payment APC:	00000
Status Indicator:	Z
Payment Indicator	3
Packaging flag:	0

If the HCPCS code is invalid, or the revenue code is invalid and the HCPCS is blank, assign default values as follows:

HCPCS APC	00000
Payment APC:	00000
Status Indicator:	W
Payment Indicator	3
Packaging flag:	0

4. If applicable based on Appendix F, assign HCPCS APC in the APC return buffer for each line item that contains an applicable HCPCS code.
5. If procedure with status indicator “C” and modifier CA is present on a claim and patient status = 20, assign payment APC 375 to “C” procedure line **and set the discounting factor to 1**. Change SI to “N” and set the packaging flag to 1 for all other line items occurring on the same day as the line item with status indicator “C” and modifier CA. If multiple lines, or one line with multiple units, have SI = C and modifier CA, generate edit 60 for all lines with SI = C and modifier CA.

Appendix K OCE Overview (cont'd)

6. If edit 18 is present on a claim, generate edit 49 for all other line items occurring on the same day as the line item with edit 18, and set the line item denial or rejection flag to 1 for each of them. Go to step 13.
7. If all of the lines on the claim are incidental, and all of the line item action flags are zero, generate edit 27. Go to step 13.
8. If the line item action flag for a line item has a value of 2 or 3 then reset the values of the Payment APC and HCPCS APC to 00000, and set the payment method flag to 4. If the line item action flag for a line item has a value of 4, set the payment method flag to 0. Ignore line items with a line item action flag of 2, 3 or 4 in all subsequent steps.
9. If bill type is 13x and condition code = 41, or type of bill = 76x, apply partial hospitalization logic from Appendix C. Go to step 11.
10. If bill type is 12x, 13x or 14x without condition code 41 apply mental health logic from Appendix C.
11. If bill type is 13x apply observation logic from Appendix H.
If bill type is not 13x, and observation G codes (G0244, G0263, G0264) present, generate edit 53.
12. If the payment APC for a line item has not been assigned a value in step 9 or 10, set payment APC in the APC return buffer for the line item equal to the HCPCS APC for the line item.
13. If edits 9, 13, 19, 20, 21, 28 39, 40, 45, 47, 49, 50, 53, 64, 65, 67, 68, 69 are present in the edit return buffer for a line item, the line item denial or rejection flag for the line item is set to 1.
14. Compute the discounting formula number based on Appendix D for each line item that has a status indicator of "T", a modifier of 73 or 50, or is a non type "T" bilateral procedure. **Note: If the SI or APC of a code is changed during claims processing, the newly assigned SI or APC is used in computing the discount formula.** Line items that meet **any** of the following conditions are not included in the discounting logic.
 - Line item action flag is 2, 3, or 4
 - Line item rejection disposition or line item denial disposition in the APC return buffer is 1 and the line item action flag is not 1
 - Packaging flag is not 0 or 3**
15. If the packaging flag has not been assigned a value of 1 or 2 in previous steps and the status indicator is "N", then set the packaging flag for the line item to 1.
16. If the submitted charges for HCPCS surgical procedures (SI = T, or SI = S in code range 10000-69999) is less than \$1.01 for any line with a packaging flag of 0, then reset the packaging flag for that line to 3 when there are other surgical procedures on the claim with charges greater than \$1.00.
17. For all bill types where APCs are assigned, apply drug administration APC consolidation logic from appendix I
18. Set the payment adjustment flag for a line item based on the criteria in Appendix G **and Appendix J.**
19. Set the payment method flag for a line item based on the criteria in Appendix E. If any payment method flag is set to a value that is greater than zero, reset the HCPCS and Payment APC values for that line to '00000'.
20. If the line item denial or rejection flag is 1 or 2 and the payment method flag has been set to 2 in the previous step, reset the payment method flag to 3.

Appendix L

Summary of Modifications

The modifications of the OCE/APC for the July 2005 release (V6.2) are summarized in the attached table. Readers should also read through the specifications and note the highlighted sections, which also indicate change from the prior release of the software.

Some OCE/APC modifications in the release may also be retroactively added to prior releases. If so, the retroactive date will appear in the 'Effective Date' column.

	Mod. Type	Effective Date	Edit	
1.	Logic	7/1/05	73	New edit 73 "Incorrect billing of blood and blood products" – RTP If blood products are billed with RC 39X and modifier BL without a corresponding line billed with RC 38X (same HCPCS, modifier and units).
2.				New Payment Adjustment Flags PAF #5 – Blood/blood product used in blood deductible calculation (Apply to blood product billed with RC 38X and modifier –BL PAF #6 – Blood processing/storage not subject to blood deductible (Apply to blood product billed with RC 39X and modifier –BL.
3.	Logic			Clarified logic such that if the SI or APC of a code is changed during claims processing, the newly assigned SI/APC will be used in all subsequent processes.
4.	Logic			Clarified logic such that Inpatient-only procedures with CA modifier that are assigned to APC 375 will have discount factor set to 1
5.	Logic			Clarified discounting logic to exclude lines that are packaged (packaging flag not zero or 3)
6.				Make HCPCS/APC/SI and modifier changes, as specified by CMS.
7.	Content		19,20, 39,40	Implement version 11.1 of the NCCI file, removing all code pairs which include Anesthesia (00100-01999), E&M (92002-92014, 99201-99499), MH (90804-90911) or Drug Admin (96400-96450; 96542-96549; 90780,90781)
8.	Content	8/1/00	19, 20, 39, 40	Reinstate CAD codes in NCCI files
9	Content	7/1/05	22	Add new modifier - BL

ATTACHMENT B

(Rev. 572, Issued: 06-01-05, Effective: 07-01-05, Implementation: 07-05-05)

FINAL

Summary of Data Changes

OCE/APC v6.2

Effective July 1, 2005

Table of Contents

CPT codes, descriptions, and material only are Copyright 2004 American Medical Association. All Rights Reserved. No fee schedules, basic units, relative values, or related listings are included in CPT. The AMA assumes no liability for the data contained herein. Applicable FARS/DFARS restrictions apply to government use.

DEFINITIONS.....	3
APC CHANGES.....	4
<u>Added APCs</u>	4
<u>APC Description Changes</u>	4
<u>APC Status Indicator Changes</u>	4
HCPCS/CPT PROCEDURE CODE CHANGES.....	4
<u>Added HCPCS/CPT Procedure Codes</u>	4
<u>Deleted HCPCS/CPT Procedure Codes</u>	5
<u>HCPCS Description Changes</u>	5
<u>HCPCS Changes- APC, Status Indicator and/or Edit Assignments</u>	6
<u>Units of Service Changes</u>	7
<u>Edit Assignments</u>	7
MODIFIERS.....	8
<u>Added Modifiers</u>	8

DEFINITIONS

- A blank in a field indicates 'no change'
- The "old" column describes the attribute prior to the change being made in the current update, which is indicated in the "new" column. If the effective date of the change is the same as the effective date of the new update, 'old' describes the attribute up to the last day of the previous quarter. If the effective date is retroactive, then 'old' describes the attribute for the same date in the previous release of the software.
- "Unassigned", "Pre-defined" or "Placeholder" in APC or HCPCS descriptions indicates that the APC or HCPCS code is inactive. When the APC or HCPCS code is activated, it becomes valid for use in the OCE, and a new description appears in the "new description" column, with the appropriate effective date.
- Activation Date (ActivDate) indicates the mid-quarter date of FDA approval for a drug, or the mid-quarter date of a new or changed code resulting from a National Coverage Determination (NCD). The Activation Date is the date the code becomes valid for use in the OCE. If the Activation Date is blank, then the effective date takes precedence.
- Termination Date (TermDate) indicates the mid-quarter date when a code or change becomes inactive. A code is not valid for use in the OCE after its termination date.

APC CHANGES

Added APCs

The following Apc(s) were added to the OCE/APC, **effective 07-01-05**

APC	APCDesc	StatusIndicator
09129	Inj clofarabine	K

APC Description Changes

The following Apc(s) had description changes, **effective 07-01-05**

APC	Old Description	New Description
00769	Ondasetron hcl oral	Ondansetron hcl oral
00869	IVIG lyophil 1G	IVIG lyophil 1g
00870	IVIG lyophil 10 MG	IVIG lyophil 10 mg
00871	IVIG non-lyophil 1G	IVIG non-lyophil 1g
00872	IVIG non-lyophil 10 MG	IVIG non-lyophil 10 mg
09436	Azathioprine parenteral,brnd	Azathioprine parenteral,brand

APC Status Indicator Changes

The following Apc(s) had Status Indicator changes, **effective 07-01-05**

APC	Old SI	New SI
09126	G	K
09127	K	G
09128	K	G

HCPCS/CPT PROCEDURE CODE CHANGES

Added HCPCS/CPT Procedure Codes

The following new HCPCS/CPT code(s) were added to the OCE/APC, **effective 01-01-05**

HCPCS	CodeDesc	SI	APC	Edit	ActivDate	TermDate
G0375	Smke/Tobacco counseling 3-10	S	01501	68	20050322	
G0376	Smoke/Tobacco counseling >10	S	01501	68	20050322	

The following new HCPCS/CPT code(s) were added to the OCE/APC, effective 04-01-05

HCPCS	CodeDesc	SI	APC	Edit	ActivDate	TermDate
K0730	Ctrl dose inh drug deliv sys	Y	00000	61		
K0731	Lith ion batt cid, on body	A	00000			
K0732	Lith ion batt cid behind ear	A	00000			

The following new HCPCS/CPT code(s) were added to the OCE/APC, effective 07-01-05

HCPCS	CodeDesc	SI	APC	Edit	ActivDate	TermDate
C9129	Inj clofarabine	K	09129			
Q9958	HOCM <=149 mg/ml iodine, 1ml	B	00000	62		
Q9959	HOCM 150-199mg/ml iodine, 1ml	B	00000	62		
Q9960	HOCM 200-249mg/ml iodine, 1ml	B	00000	62		
Q9961	HOCM 250-299mg/ml iodine, 1ml	B	00000	62		
Q9962	HOCM 300-349mg/ml iodine, 1ml	B	00000	62		
Q9963	HOCM 350-399mg/ml iodine, 1ml	B	00000	62		
Q9964	HOCM >= 400 mg/ml iodine, 1ml	B	00000	62		
S0118	Ziconotide intrathecal 1mcg	E	00000	28		
S0133	Histerlin implant	E	00000	28		
S0145	Peg interferon alfa-2B/10	E	00000	28		
S0146	Peg interferon alfa-2B/10	E	00000	28		
S0198	Inj pegaptanib 0.3 mg	E	00000	28		
S0265	Genetic counsel 15 mins	E	00000	28		
S0613	Ann breast exam	E	00000	28		
S2900	Robotic surgical system	E	00000	28		
S8270	Enuresis alarm	E	00000	28		

Deleted HCPCS/CPT Procedure Codes

The following HCPCS/CPT code(s) were deleted from the OCE/APC, effective 07-01-05

HCPCS	CodeDesc	StatusIndicator	APC
C9126	Injection, natalizumab	E	0

HCPCS Description Changes

The following code descriptions were changed, effective 07-01-05

HCPCS	Old Description	New Description
C9724	EPS gast cardia plic	EPS gast cardia plic
G9017	Amantadine HCL, oral	Amantadine HCL 100mg oral
G9018	Zanamivir, inh pwdr	Zanamivir, inhalation pwd 10m
G9019	Oseltamivir phosp	Oseltamivir phosphate 75mg
G9020	Rimantadine HCL	Rimantadine HCL 100mg oral
G9034	Zanamivir, inh pwdr, brand	Zanamivir powder via inhaler
G9035	Oseltamivir phosp, brand	Oseltamivir phosphate 75mg o
G9036	Rimantadine HCL, brand	Rimantadine HCL 100mg
G9043	Low vision rehab therapist	Low vision rehab therapist
Q4079	Injection, natalizumab	Injection, Natalizumab, 1 MG
Q9941	IVIG lyophil 1G	IVIG lyophil 1g

HCPCS	Old Description	New Description
Q9942	IVIG lyophil 10 MG	IVIG lyophil 10 mg
Q9943	IVIG non-lyophil 1G	IVIG non-lyophil 1g
Q9944	IVIG non-lyophil 10 MG	IVIG non-lyophil 10 mg
Q9955	Inj perflexane lip micros, ml	Inj perflexane lip micros,ml
Q9957	Inj perflutren lip micros, ml	Inj perflutren lip micros,ml

HCPCS Changes- APC, Status Indicator and/or Edit Assignments

The following code(s) had an APC and/or SI and/or edit change, **effective 01-01-04** **A blank in the field indicates no change.

HCPCS	CodeDesc	Old APC	New APC	Old SI	New SI	Old Edit	New Edit
J8521	Capecitabine, oral, 500 mg			E	B	28	62

The following code(s) had an APC and/or SI and/or edit change, **effective 04-01-04** **A blank in the field indicates no change.

HCPCS	CodeDesc	Old APC	New APC	Old SI	New SI	Old Edit	New Edit
L0960	Post surgical support pads			E	A	28	N/A

The following code(s) had an APC and/or SI and/or edit change, **effective 01-01-05** **A blank in the field indicates no change.

HCPCS	CodeDesc	Old APC	New APC	Old SI	New SI	Old Edit	New Edit
0064T	Spectroscop eval expired gas	00000	00367	A	X		
0065T	Ocular photoscreen bilat			A	E	N/A	50
E0950	Tray			E	A	13	N/A
E0951	Loop heel			E	A	13	N/A
E0952	Toe loop/holder, each			E	A	13	N/A
K0630	SIO flex pelvisacral prefab			Y	A	61	N/A
K0631	SIO flex pelvisacral custom			Y	A	61	N/A
K0632	SIO panel prefab			Y	A	61	N/A
K0633	SIO panel custom			Y	A	61	N/A
K0634	LO flexibl L1-below L5 pre			Y	A	61	N/A
K0635	LO sag stays/panels pre-fab			Y	A	61	N/A
K0636	LO sagitt rigid panel prefab			Y	A	61	N/A
K0637	LO flex w/o rigid stays pre			Y	A	61	N/A
K0638	LSO flex w/rigid stays cust			Y	A	61	N/A
K0639	LSO post rigid panel pre			Y	A	61	N/A
K0640	LSO sag-coro rigid frame pre			Y	A	61	N/A
K0641	LSO sag-cor rigid frame cust			Y	A	61	N/A
K0642	LSO flexion control prefab			Y	A	61	N/A
K0643	LSO flexion control custom			Y	A	61	N/A
K0644	LSO sagit rigid panel prefab			Y	A	61	N/A
K0645	LSO sagittal rigid panel cus			Y	A	61	N/A
K0646	LSO sag-coronal panel prefab			Y	A	61	N/A
K0647	LSO sag-coronal panel custom			Y	A	61	N/A
K0648	LSO s/c shell/panel prefab			Y	A	61	N/A
K0649	LSO s/c shell/panel custom			Y	A	61	N/A

The following code(s) had an APC and/or SI and/or edit change, **effective 07-01-05** **A blank in the field indicates no change.

HCPCS	CodeDesc	Old APC	New APC	Old SI	New SI	Old Edit	New Edit
0017T	Photocoagulat macular drusen	00000	00235	E	T	28	N/A
38204	Bl donor search management			E	N	28	N/A
48554	Transpl allograft pancreas			E	C	14	N/A
59050	Fetal monitor w/report			E	M	14	72
59510	Cesarean delivery			E	B	14	62
93010	Electrocardiogram report			A	B	N/A	62
96549	Chemotherapy, unspecified	00000	00116	N	S		
C9127	Paclitaxel protein pr			K	G		
C9128	Inj pegaptamib sodium			K	G		
E0203	Therapeutic lightbox tabletp			E	A	9	N/A
G0179	MD recertification HHA PT			E	M	14	72
G0180	MD certification HHA patient			E	M	14	72
G0181	Home health care supervision			E	M	14	72
G0182	Hospice care supervision			E	M	14	72
G0250	MD review interpret of test			E	M	28	72
L8620	Repl lithium ion battery			A	E	N/A	28
Q4079	Injection, Natalizumab, 1 MG			G	K		

Units of Service Changes

The following code(s) were assigned to the following "units of service", **effective 07-01-05**

HCPCS	Old Max Units	New Max Units
36430	0	1

Edit Assignments

The following code(s) were added to edit 67, 68, or 69 **effective 10-01-03**

HCPCS	Edit#	ActivDate	TermDate
G0297	69	20031001	20050128

The following code(s) were added to edit 67, 68, or 69 **effective 01-01-05**

HCPCS	Edit#	ActivDate	TermDate
G0337	69	20050101	20050128

The following code(s) were deleted as blood products, **effective 07-01-05**

HCPCS
86890
P9041
P9045
P9046

HCPCS
P9047

The following code(s) were added to edit 55 "Non Reportable for Site of Service", **effective 07-01-05**

HCPCS	Edit#
C9129	55

MODIFIERS

Added Modifiers

The following modifier(s) were added to the list of valid modifiers, **effective 07-01-05**

modifier
BL