

DOT/FAA/AR-05/34

Office of Aviation Research
Washington, D.C. 20591

High-Speed Bolthole Eddy-Current Scanning for In-Service Inspection of Engine Disks

September 2005

Final Report

This document is available to the U.S. public
through the National Technical Information Service (NTIS),
Springfield, VA 22161.



U.S. Department of Transportation
Federal Aviation Administration

NOTICE

This document is disseminated under the sponsorship of the U.S. Department of Transportation in the interest of information exchange. The United States Government assumes no liability for the contents or use thereof. The United States Government does not endorse products or manufacturers. Trade or manufacturer's names appear herein solely because they are considered essential to the objective of this report. This document does not constitute FAA certification policy. Consult your local FAA aircraft certification office as to its use.

This report is available at the Federal Aviation Administration William J. Hughes Technical Center's Full-Text Technical Reports page: actlibrary.tc.faa.gov in Adobe Acrobat portable document format (PDF).

1. Report No. DOT/FAA/AR-05/34		2. Government Accession No.		3. Recipient's Catalog No.	
4. Title and Subtitle HIGH-SPEED BOLTHOLE EDDY-CURRENT SCANNING FOR IN-SERVICE INSPECTION OF ENGINE DISKS				5. Report Date September 2005	
				6. Performing Organization Code	
7. Author(s) Lisa Brasche², Tony Mellors, Thadd Patton³, Rob Stephen, Kevin Smith⁴, Andy Kinney, Waled Hassan, Jim Ohm, and Joel Schraan¹				8. Performing Organization Report No.	
9. Performing Organization Name and Address ² Iowa State University Center for NDE Ames, IA 50011 ³ General Electric Aircraft Engines Cincinnati, Ohio ⁴ Pratt & Whitney 400 Main Street East Hartford, CT 06108 ¹ Honeywell Engines, Systems & Services 111 S. 34 th Street Phoenix, Arizona 85072				10. Work Unit No. (TRAIS)	
				11. Contract or Grant No.	
12. Sponsoring Agency Name and Address U.S. Department of Transportation Federal Aviation Administration Office of Aviation Research Washington, DC 20591				13. Type of Report and Period Covered Final Report	
				14. Sponsoring Agency Code ANE-100	
15. Supplementary Notes The FAA William J. Hughes Technical Center Technical Monitors were Rick Micklos, Paul Swindell, and Cu Nguyen.					
16. Abstract <p>High-speed bolthole (HSBH) eddy-current inspection is the most popular inspection technique for fast and accurate inspection of circular air- and boltholes. When HSBH techniques were introduced in the field, inspection differences among original equipment manufacturer (OEM) techniques were unclear. Also unavailable were quantification of inspection capability and identification of the main sources of variation for this inspection technique. A three-factor, two-level design of experiment was conducted to determine the main sources of variations to better control the inspection process. A semiautomated scanner prototype was designed and manufactured to minimize these variations. The scanner and associated fixturing were then tested to compare the process capability and reliability with that of the typical manual field technique. Both approaches were found to exceed the program performance metric of detecting a 30-mil crack with 4:1 signal-to-noise ratio in a common bolthole geometry. The semiautomated scanner showed a 30% improvement in the 90% probability of detection point with 95% confidence (12-mil crack) compared to a manual inspection (17-mil crack) using experienced eddy-current inspectors and relatively short 0.25" long bolthole crack specimens. Scanner reliability testing resulted in a written inspection technique that was jointly used by the OEMs and served to further improve the inspection. Information gained in the process of improving this inspection was used to make recommendations for possible modification of the industry specification, SAE AS4787, "Eddy Current Inspection of Circular Holes in Nonferrous Metallic Hole Inspection in Aircraft Engines."</p>					
17. Key Words In-service inspection, Eddy-current, Bolthole, Jet engine			18. Distribution Statement This document is available to the public through the National Technical Information Service (NTIS) Springfield, Virginia 22161.		
19. Security Classif. (of this report) Unclassified		20. Security Classif. (of this page) Unclassified		21. No. of Pages 63	22. Price

TABLE OF CONTENTS

	Page
EXECUTIVE SUMMARY	vii
1. INTRODUCTION	1
1.1 Purpose	1
1.2 Objectives	1
1.3 Background	1
1.4 Related Activities and Documents	2
2. TECHNICAL APPROACH	2
3. DISCUSSION OF RESULTS	3
3.1 Survey of OEM Current HSBH Inspection Practices	3
3.2 Determination of Key Inspection Parameters Contributing to Inspection Variability Through DOE Study	4
3.3 Conclusions of DOE	6
3.4 Design and Fabrication of Common Fixtures and Tooling	7
3.5 Semiautomated vs Manual HSBH Eddy-Current Inspection Process Capability Evaluation	12
3.6 Process Capability Results	14
4. CONCLUSIONS	15
5. REFERENCES	16
APPENDICES	
A—Main Effects and Interaction Plots Generated in the DOE Study Designed to Determine the Important Parameters Used in HSBH Inspection	
B—Design Drawings of the Common Tooling and Fixtures	
C—Probability of Detection Inspection Technique and Data Collection Sheet	
D—Draft Revision of Industry Standard AS4787	

LIST OF FIGURES

Figure		Page
1	Design of Experiment Overall Results (Units are Uncoded)	7
2	FML100146 PoD Specimen Set Used in This Study	9
3	Semiautomated Scanner on Top of Power Supply Box	10
4	Adapter Plates Fabricated for the Semiautomated Scanner	10
5	Specimen-Centering Pin and Bolthole Simulator Plate	11
6	Overall PoD Results for HSBH Inspection Using Manual Scanner	14
7	Overall PoD Results for HSBH Inspection Using Semiautomated Scanner Developed Under This Effort	15

LIST OF TABLES

Table		Page
1	High-Speed Bolthole Eddy-Current Scanning OEM Practices	4
2	Design of Experiment Factors and Levels	6
3	Crack Surface Lengths for the 0.328" Diameter IN718 Bolthole Specimens Used in the DOE Study	6
4	Evaluation Metrics for the Analysis of the Results of the DOE Study	6
5	Comparison of the Manual and Semiautomated HSBH Inspection Results to the Program Metric	14

LIST OF ACRONYMS

DOE	Design of experiments
EDM	Electron discharge machined
ETC	Engine Titanium Consortium
FAA	Federal Aviation Administration
GE	General Electric
HSBH	High-speed bolthole eddy-current inspection
OEM	Original equipment manufacturer
P-P	peak-to-peak
rpm	Revolutions per minute
SNR	Signal-to-noise ratio

EXECUTIVE SUMMARY

Nondestructive inspection of in-service critical jet engine rotating parts is key to the success of the Federal Aviation Administration (FAA) enhanced inspection initiative. Typical jet engine disks contain numerous stress-concentrating geometries, such as dovetail slots, boltholes, and air holes. Many of these features are subjected to substantial stresses under operating conditions. Nondestructive inspection of these complex features is vital, since undetected cracks can grow to critical size and potentially result in disk failure. This program is focused on evaluating existing eddy-current procedures for boltholes and documenting a best practice for inspection of these features in critical rotating parts.

High-speed bolthole (HSBH) eddy-current inspection is an effective, efficient, and commonly used technique for conducting fast and accurate inspection of air- and boltholes. Although several HSBH techniques have been introduced in the field by all the original equipment manufacturers, no studies of the comparative effectiveness and quantitative fatigue crack detection capabilities of the various techniques have been completed.

This report describes an investigation into the main sources of variation of HSBH eddy-current inspection through the design and evaluation of a three-factor, two-level design of experiment test matrix. A semiautomated scanner prototype was designed and manufactured to minimize the impact of the identified inspection variations on inspection performance. The scanner and associated fixturing were tested, and probability of detection (PoD) curves were constructed to compare the process capability and reliability with that of a typical manual field technique. Both the manual and semiautomated inspection approaches were found to exceed the program performance metric of detecting a 0.030" long crack with a 4:1 signal-to-noise ratio in a typical bolthole geometry. The semiautomated scanner demonstrated a 30% improvement in both 90/50 and 90/95 PoD flaw size over the manual inspection method using experienced eddy-current inspectors and relatively shallow (0.250" deep) bolthole crack specimens.

In addition to the investigation into the main sources of variation, this study also provided data and procedures, enabling a standardized written inspection technique or best practice to be prepared for the industry specification, SAE AS4787, "Eddy-Current Inspection of Circular Holes in Nonferrous Metallic Hole Inspection in Aircraft Engines."

1. INTRODUCTION.

1.1 PURPOSE.

Application of high-speed bolthole (HSBH) eddy-current inspection has increased significantly as the aircraft engine industry continues to expand the scope and extent of their in-service inspections of critical rotating part features for fatigue cracks in support of the Federal Aviation Administration (FAA) Enhanced Inspection Initiative. The Engine Titanium Consortium (ETC), other original equipment manufacturers (OEM), the airlines, and the FAA have placed an emphasis on the importance of quantifying and improving the reliability of these inspections. This study has been initiated to (1) determine the primary sources of variation in a typical in-service manual eddy-current inspection, (2) rank these variations according to relative influence, (3) fabricate tooling and semiautomated test equipment to improve inspection reproducibility and reliability, and (4) quantify and compare the resulting process capability to that of the current manual field practice.

1.2 OBJECTIVES.

The primary objectives of this study were

- to develop common fixtures to reduce inspection variables and arrive at a standardized inspection technique.
- to measure the eddy-current bolthole inspection process capability.
- to use this information to develop an industry best practices document.

1.3 BACKGROUND.

In 1998, the FAA the announced the Safer Skies initiative, which aimed to reduce the commercial aviation accident rate by 80 percent by 2007. Commercial aviation safety is one of the three areas of the Safer Skies initiative that addressed accident causes such as uncontained engine failures, one of the leading causes of commercial aviation fatalities. As part of this program, government and industry have agreed to use enhanced inspections for certain high-energy, rotating engine components. Critical features were identified by the OEMs for enhanced inspection at opportunities when the disks were available as part of routine overhaul and maintenance actions. Among the most significant and important features to be inspected were air- and boltholes, typical of those machined in critical engine components.

Compared to fully automated bolthole inspection systems, the semiautomatic HSBH inspection evaluated in this study is a simple, low-cost technique that can achieve acceptable commercial crack detection sensitivity. Precision fully automated eddy-current equipment costs can exceed \$200,000, while the cost of a hand-held probe rotator and instrumentation is typically less than \$20,000. HSBH inspection is also preferred over fluorescent penetrant inspection for detection of cracks in critical engine features. This is particularly true for inspection of high length-to-diameter ($l/d > 1$) holes often found in critical rotating components where line-of-site access is severely restricted or obstructed.

OEM HSBH inspection practices and reliability data are usually maintained in field manuals or considered proprietary information and, therefore, are not publicly available. There are, for example, a variety of eddy-current coil configurations used by the different OEMs for bolthole inspection, including absolute (single coil), differential (dual coil), split-core differential (close proximity dual coils), and reflection (driver-pickup) in both absolute and differential configurations. Likewise, a variety of hand-held probe rotators operating at a number of rotational speeds are commonly used for commercial bolthole inspection. Probe translation through the bolthole length is performed manually or by using a semiautomated fixture. Manual inspection is generally expected to produce a higher level of variability than semiautomated systems.

The industry specification for circular hole inspection, SAE AS4787 [1], was written in 1992. Since then, significant technical advances in inspection techniques of critical rotating parts were developed by OEMs. Part of this project was to draft a new SAE AS4787 to reflect these improvements.

1.4 RELATED ACTIVITIES AND DOCUMENTS.

The ETC was established in 1993 by Iowa State University in cooperation with General Electric (GE), Pratt & Whitney, and Honeywell. The primary goal of the ETC program was to provide improved inspection technology for engine materials and components. Several FAA reports have been generated that highlight the work [2 and 3] completed over the past 11 years. All FAA reports are available on-line at <http://actlibrary.tc.faa.gov/>. Related papers and publications are provided at <http://www.cnde.iastate.edu/etc/>.

2. TECHNICAL APPROACH.

The initial work of this study focused on identification and evaluation of existing OEM inspection processes practiced by the ETC partners that manufacture large commercial engines. Eddy-current inspection has changed substantially over the years, and current OEM techniques, approaches, and experiences were used to define practices and establish parameters to be included in the experimental study and instrumentation design.

The second part of this study involved a design of experiments (DOE) [4] exercise to determine if the major inspection parameters not under strict procedural control (i.e., subject to inspector variability) had a significant effect on inspection results. Inspection parameters, having the highest potential to adversely affect test results, were scan density (i.e., speed and feed) and off-normal response (angle). Variation of these parameters is typically accentuated during manual scanning.

The third part of this study was to develop optimum eddy-current fixturing to permit improved control of the most critical inspection parameters identified in the second part of the study. Development of optimum inspection fixturing was completed and incorporated into a prototype portable semiautomated scanner. Although some OEM-manufactured eddy-current fixturing had been developed prior to this study, none addressed both the probe alignment and feed rate issues.

The fourth part of this study was to use the common fixtures developed in the third part to arrive at a standardized best practice inspection technique and quantify process sensitivity. PoD testing of both the semiautomated scanner and manual hand-held inspections were conducted by four different inspectors at two different facilities. This also involved fabricating tooling to precisely and repeatably locate bolthole test specimens in a simulated disk pattern.

The performance metric was detection of a 0.030" long crack with a 4:1 signal-to-noise ratio (SNR) in a common bolthole geometry. These metrics represent current state-of-the-art capability for a production eddy-current bolthole inspection.

3. DISCUSSION OF RESULTS.

3.1 SURVEY OF OEM CURRENT HSBH INSPECTION PRACTICES.

Current in-service OEM practices for HSBH eddy-current inspection of engine disks were surveyed and found to be similar for the two primary users, with the major parameters summarized in table 1. A review of the manufacturer's equipment showed OEM practices consistent with the range of available bolthole scanners, instruments, and probes.

The eddy-current hole inspection practice of OEM 2 was limited exclusively to a manual inspection with hand feed, while OEM 1 typically employed a semiautomated inspection system with hand feed. Both OEMs occasionally employed a simple fixture to assist in maintaining probe alignment and normality with the surface of the hole.

Procedural guidelines are currently used to control the maximum feed rate in a particular scan, although adherence to the guidelines is totally dependent on the operator. For instance, an inspector may be instructed not to exceed 0.5 in./sec. when feeding the probe through the hole, but there is no documentation to verify that the feed rate limit was not exceeded during the test. Probe type and size show widespread use of reflection differential type probes with increasingly smaller nominal coil diameters in the range of 0.040" to 0.060".

TABLE 1. HIGH-SPEED BOLTHOLE EDDY-CURRENT SCANNING
OEM PRACTICES

Inspection Variables	OEM 1	OEM 2
Parameter		
Frequency of operation	1-6 MHz	2 MHz
Scan speed	800-3000 rpm	800-3000 rpm
Filter	250-1000 Hz (rpm dependent)	200-300 Hz HP/500-1500 Hz LP
Probe type	Contact	Contact
Element type	Reflection, differential, and absolute	Driver—pickup (reflection)
Element size	0.080" diameter coil	Not specified
Data recording	Screen shot/digital archive	None/digital archive
Inspection method	Hand-held and fixtured rotator with manual feed	Hand-held rotator with manual feed
Scan resolution (e.g., pitch or increment)	0.025 max	Not specified
Other considerations		
Calibration feature size—corner	0.015" long by 0.015" deep EDM	Not specified
Calibration feature size—barrel	0.030" long by 0.015" deep EDM	0.030" long by 0.015" deep EDM
Flaw rejection level	100 % of calibration slot response	50% of calibration response
Hole diameter range	0.250"-2.500"	0.175"-1.00"
Hole depth range	0.0625"-4.00"	0.125"-2.0"
Materials	Titanium/nickel alloys	Ti 6-4/Inconel/R88
Corner geometry	Machined	Machined
Angled entry surfaces	No	Yes
Other	3:1 min. SNR	Not applicable

EDM – Electron discharge machined

3.2 DETERMINATION OF KEY INSPECTION PARAMETERS CONTRIBUTING TO INSPECTION VARIABILITY THROUGH DOE STUDY.

The team identified three key test parameters that could have a significant effect on inspection sensitivity.

- Probe rotational speed (i.e., revolutions per minute (rpm))
- Probe angle (i.e., deviation from normal)
- Probe feed rate (i.e., increment per revolution)

These parameters were selected because of their potential contributions to the inspection variability relative to scan data density (i.e., speed and feed) and off-normal response associated with manual scanning. Furthermore, the effects of other inspection parameters such as instrument, probe selection, signal phase, and filtering could be minimized through the use of standardized setup and calibration procedures.

Evaluation of a full factorial DOE was identified as the most efficient method to measure process sensitivity to the key inspection parameters. The DOE design and summary results were as follows:

- a. The DOE was a three-factor, two-level full factorial design (two [4] or eight combinations) blocked for motor speed and randomized within each block. The limits associated with each parameter are shown in table 2.
- b. Eddy-current amplitude and noise levels were the response metric established for the DOE study. This information was collected during the study on several low-cycle fatigue cracks in 0.328" diameter, Inconel (IN718) bolthole specimens. Crack surface length-to-depth ratio was nominally 2:1. Crack surface lengths used in the study are summarized in table 3.
- c. The evaluation metrics for the analysis of the results from the DOE study are summarized in table 4. These guidelines were used to establish the relative importance of the inspection parameters investigated in the study.
- d. The DOE study was conducted using a fully automated scanning system that provided total control of the inspection parameters under investigation. The following components and procedures were used:
 - A Rohmann Elotest instrument and bolthole scanners.
 - A fully automated ETC2000 scanner used for feed and angle control, and data acquisition and analysis.
 - A 2-MHz reflection differential coil, unshielded, 0.040" coil diameter served as the inspection probe.
 - Calibrations were performed on a 0.030" long by 0.015" deep electron discharge machined (EDM) notch located in a 0.341" diameter, IN718 bolthole specimen. Calibrations were optimized in phase and filter for each rpm with a 0° probe angle.

TABLE 2. DESIGN OF EXPERIMENT FACTORS AND LEVELS

Factors	Levels	
	(-1)	(1)
Probe (rpm)	1200	2200
Probe feed rate (in./sec)	0.125	0.750
Probe angle (degrees)	0	2

TABLE 3. CRACK SURFACE LENGTHS FOR THE 0.328" DIAMETER IN718 BOLTHOLE SPECIMENS USED IN THE DOE STUDY

Specimen ID	Crack Length (inches)
19	0.007
04	0.016
20	0.020
07	0.034
18	0.041
14	0.050
13	0.061

TABLE 4. EVALUATION METRICS FOR THE ANALYSIS OF THE RESULTS OF THE DOE STUDY

Metric	Optimum Response
Largest missed crack	Minimum
Amplitude of largest crack	Maximum
Noise	Minimum
SNR	Maximum

3.3 CONCLUSIONS OF DOE.

Difficulties associated with characterization of noise levels resulted in measurement of only two noise variables (i.e., high and low noise). All measurements were made in the scan-up direction. Peak-to-peak (P-P) noise measurements were made in an approximate 0.100" long window on the lower side of the flaw location in each specimen. Two noise measurements (maximum P-P noise of the entire window and the baseline noise value excluding any discrete, noise spikes) were taken from this window location in each specimen. Only the maximum P-P noise value was evaluated, since it was judged as most representative of typical scan-generated noise from vibration, chatter, and hole irregularities.

The data analysis tool used in the DOE study was Minitab™, which was useful for determining the relative influence of the main effects (angle, feed, and rpm) as well as identifying parameter interaction effects. Resultant values have no associated units. The following is a summary of

the important observations based on the main effects and interaction plots generated in this DOE study. Complete results are attached as appendix A.

- Small flaw detection (i.e., largest missed crack)
 - Both main and interaction effects show a high sensitivity to all three factors (i.e., rpm, feed rate, and angle), with optimum conditions favoring a 0° probe angle, slow feed rate, and high rpm.
- Signal amplitude (large crack)
 - Main effects plots show a high sensitivity to probe angle with the optimum condition favoring a 0° probe angle. The probe rotational speed (rpm) and feed rate effects are negligible for large flaw amplitudes.
- Noise and SNR (high-noise case only)
 - Main effects plots show a high sensitivity to probe angle with the optimum condition favoring a 0° probe angle. Interaction plots show sensitivity, albeit to a lesser and sometimes conflicting level, to both probe rotational speed (rpm) and feed rate.

The primary conclusions derived from the Minitab analysis of the DOE data are that probe angle, feed rate, and rotational speed (rpm), in that order, have significant effects on the results of HSBH inspection, as shown in figure 1.

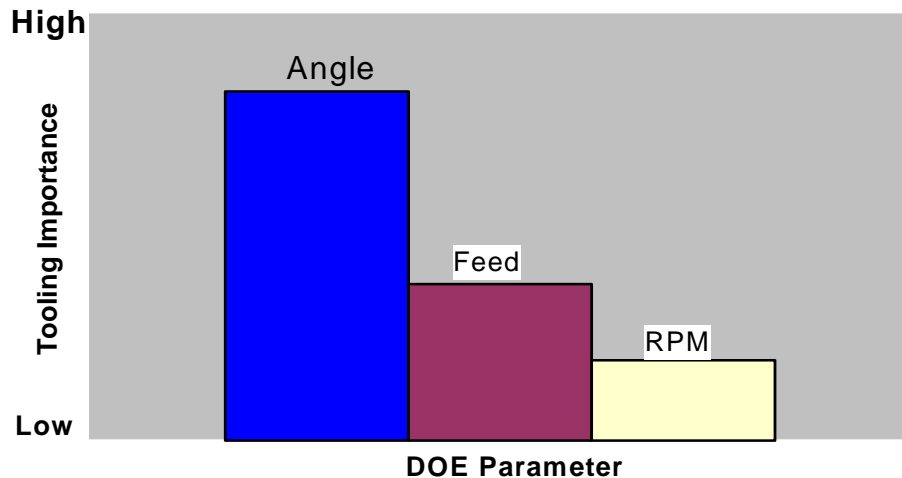

FIGURE 1. DESIGN OF EXPERIMENT OVERALL RESULTS (UNITS ARE UNCODED)

3.4 DESIGN AND FABRICATION OF COMMON FIXTURES AND TOOLING.

The DOE study showed very clearly that probe angle, probe translational speed, and rotational speed all significantly influence inspection sensitivity. Therefore, it was evident that a probe

translation and alignment control device that would securely hold the probe rotator would be vital to the success of the inspection. The ETC technical team created detailed specifications for the tooling and fixtures needed to achieve the proper level of control over the probe angle, probe translational speed, and rotational speed. Allen Design, located in Tempe, Arizona, was selected to design and manufacture the following items.

- Probe Translation Device. This device was required to precisely position and translate a rotating eddy-current probe through boltholes of various diameters. The probes were mounted to commercial off-the-shelf, high-speed bolthole eddy-current rotating drivers and used to detect fatigue cracks along the length of the boltholes. There were a number of different probe-rotating drivers available, so the device was designed to be compatible with many of these drivers. The probe translation device had to be adaptable to different engine parts. The following requirements were imposed during the design process:
 - Fixtured alignment to control wobble of probe while translating through a hole feature.
 - Fine X-Y plane adjustment to center probe within bolthole diameter.
 - Machine control of probe travel through boltholes by means of selectable, fixed, transverse speeds of 0, 0.100", and 0.200 in./sec in a helical scan pattern.
 - Rapid, adjustable, automatic translation retraction to a start next scan position.
 - Scan limit switch to prevent excess travel of probe.
 - Minimum of 3" of probe translation travel.
 - Slip clutch to prevent burnout of translation motor.
 - Use of exchangeable bolt-on adapter plates for fit to specific parts and bolthole patterns.
 - Adaptability to Uniwest probe rotating driver and also other drivers including Roman Elotest, Foerster, Zetec, etc., as provided.
 - No electrical interference to be caused by the probe translation device during the eddy-current inspection process (including data acquisition).
 - Manufacturing cost of less than \$10,000 (This goal was not met for the prototype built under this task, but may be achievable for larger production volume).
- Part Adapter Plate. To adapt the proposed bolthole-scanning system design to various parts and facilitate inspection of each hole, the instrument must be manually lifted and secured for each bolthole by an exchangeable adapter plate designed for that purpose. These adapter plates bolt to the bottom of the translation device. To precisely adjust the eddy-current probe within a bolthole, a fine X-Y adjustment was provided that also

locked the probe into the correct position within the hole. The program included the design and manufacture of two such adapter plates, one to be used with the bolthole simulator fixture and the other to be used for the inspection of a preselected industry application. GE provided an actual engine rotating part for the inspection demonstration. Therefore, an adapter plate was fabricated for the GE component.

- **Bolthole Simulator Fixture.** The bolthole simulator fixture was used to precisely position round bolthole specimens (see figure 2) in a circular layout as they would be in a typical rotating engine component. This fixture was capable of positioning 25, 1.875" diameter by 0.250" thick specimens. The bolthole diameter within these circular specimens is 0.460". The layout aligns the specimens in a precise circular pattern, with the boltholes within 0.002" of the geometric center. When specimens are aligned by the fixture, they can then be locked into position to prevent rotation and lift-out during scanning.

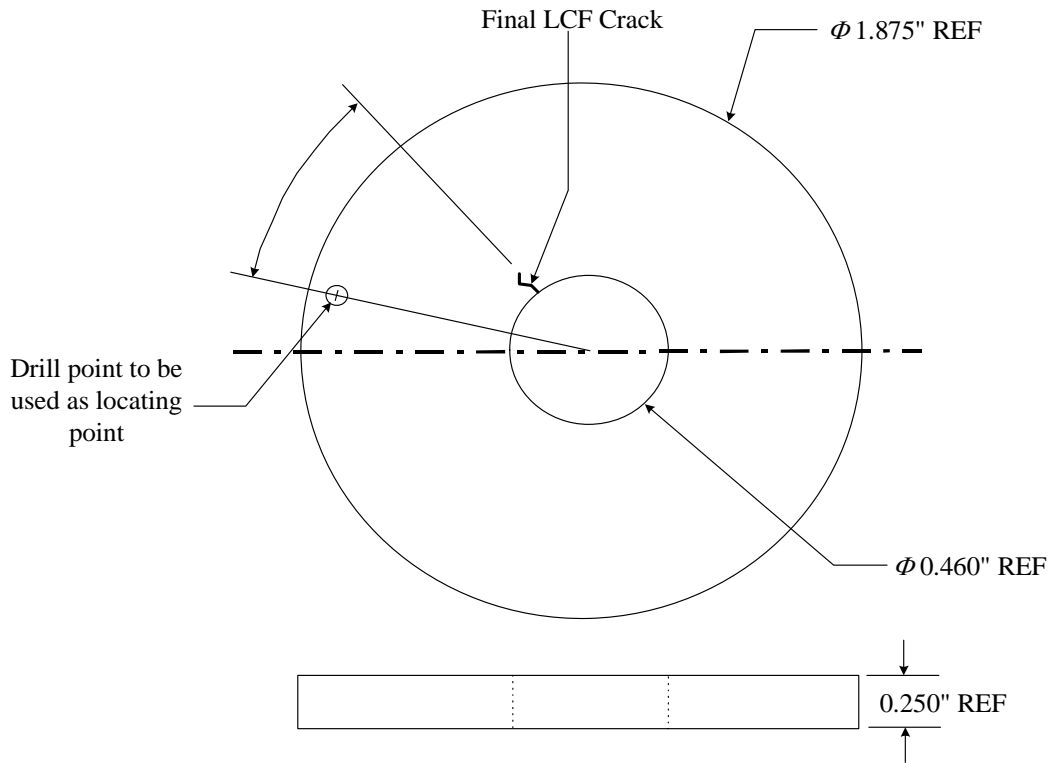

FIGURE 2. FML100146 PoD SPECIMEN SET USED IN THIS STUDY

The design drawings for the common tooling, fixtures, and the semiautomated scanner are attached as appendix B to this report. Figures 3, 4, and 5 illustrate the final components manufactured by Precision Gage, a tooling workshop located in Tempe, Arizona.

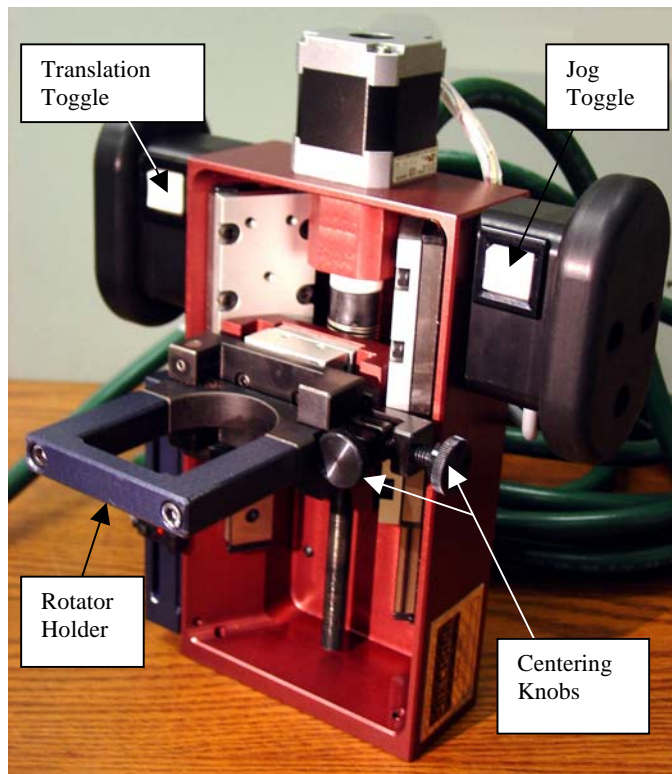

FIGURE 3. SEMIAUTOMATED SCANNER ON TOP OF POWER SUPPLY BOX

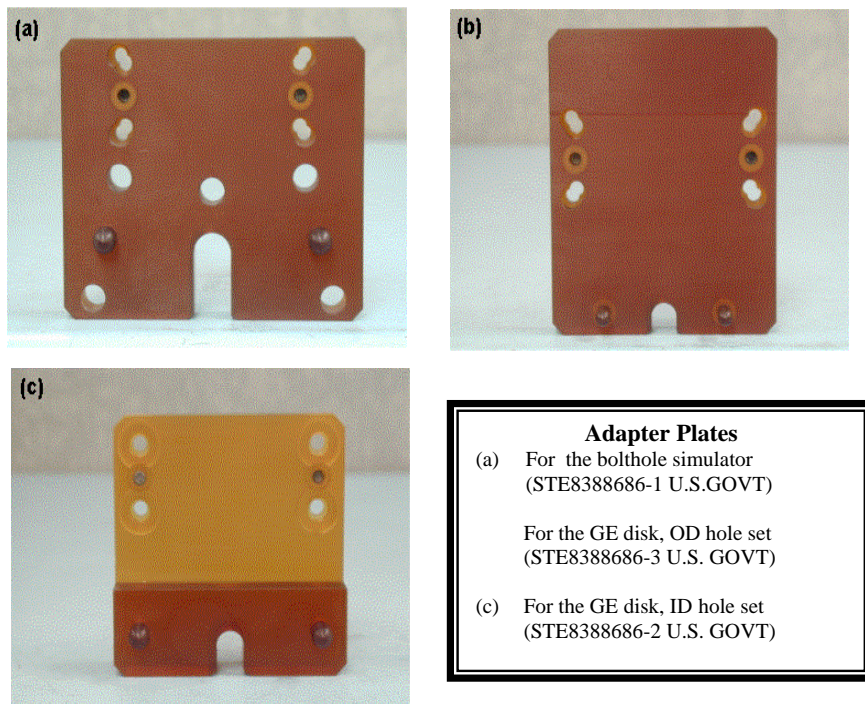

FIGURE 4. ADAPTER PLATES FABRICATED FOR THE SEMIAUTOMATED SCANNER

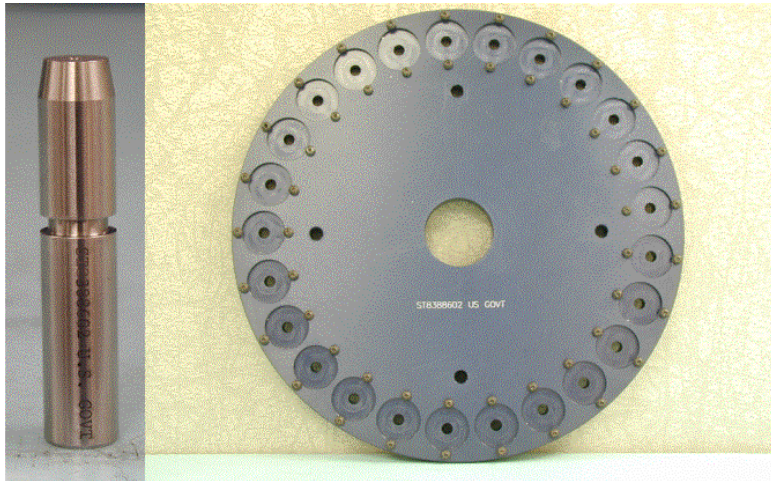

FIGURE 5. SPECIMEN-CENTERING PIN AND BOLTHOLE SIMULATOR PLATE

Scanner modifications were completed as necessary during initial testing. Modifications included changing the thumb toggles to easily peak-out indications, moving the speed control from the power supply to the scanner body, modifying the rotator bracket to better secure the Elotest rotator, and milling out the specimen adapter for precision fitting. Scanner drawings were then modified to show the speed selector on the scanner body, cable disconnect at the driver box, and the clearance change made to the adapter. The three-position motion control switch permitted a minimum of 0.008" to 0.010" of probe travel when toggled at a 0.1-in./sec speed and a minimum of 0.010" to 0.030" of probe travel when toggled at a 0.2-in./sec speed. The high-speed setting was useful for initial positioning of the eddy-current probe. The jog toggle is located on the right thumb toggle and moves 0.001" to 0.002" per jog or 0.006 in./sec when held down. Although these settings can be modified with a program change, they were proven effective in testing performed during this study.

Two microlimit switches controlled the travel range of the probe. This provided economy of motion and reduced the total time of the bolthole inspection. Fine adjustment screws allowed for easy probe centering within a bolthole. With properly toleranced part fixtures, the scanner was rapidly positioned for the next bolthole. Probe alignment with the translating axis was precise, and no bolthole axes misalignment difficulties were experienced over the full extent of probe travel. These switches controlled the probe alignment and the probe feed rate and translation speed variables identified as important during the DOE portion of this study.

The following is a summary of the principal features of the semiautomated prototype scanner.

- Fixtured alignment to control wobble and alignment
- No electrical interference from scanner to eddy-current instrumentation
- Machine control of probe travel (feed) through bolthole

- Use of exchangeable adapter plates (alignment templates) for precise fit to specific parts
- Fine X-Y plane adjustment to center probes within bolthole diameter
- Switch-selectable fixed transverse speeds of 0.100" or 0.200 in./sec
- Jog control for 0.001" to 0.002" minimum or 0.006 in./sec when held down
- Rapid retraction mode to increase inspection speed of 0.700 in./sec
- Microlimit switches to prevent excess travel of probe
- 3" of probe travel
- Adaptability to multiple probe rotators including UniWest, Roman Elotest, and Foerster (requires custom adapter for each probe rotator)
- Prototype price, which included initial design costs, was \$23,000. Subsequent units would be priced at less than \$14,000, depending upon volume.

The precision adapter plate provided hole centering within ± 0.002 ", and the centering tool helped achieve quick placement of the PoD specimens for testing the other half of the specimen set.

3.5 SEMIAUTOMATED VS MANUAL HSBH EDDY-CURRENT INSPECTION PROCESS CAPABILITY EVALUATION.

PoD tests of both the semiautomated and manual hand-held scanners were conducted using four different inspectors at two different facilities. All the inspectors were experienced in bolthole inspection. Each inspector completed two runs with the manual inspection and two runs with the semiautomated inspection. A single test protocol was followed to standardize the tests and keep it on schedule. Prior to the first inspection run, each inspector was briefed on the PoD test procedure and the data report form. A written inspection technique was available for set-up and reference (see appendix C). Two inspection runs could be completed in a day under optimal conditions. Each run included two specimen change outs since the test fixture was designed to contain only half of the PoD test specimens.

A schematic of the bolthole PoD specimens used in this study is presented in figure 3. The specimens are 0.250" thick disks of titanium 6-2-4-6 from a U.S. Government-owned test set FML100146. The 1.875" diameter specimens each contained a 0.460" diameter center-aligned bolthole. Measurement of all bolthole diameters indicated they were within 0.001" of their nominal 0.460" diameter. This bolthole diameter is typical of those commonly inspected by the OEMs, as indicated in the OEM survey. It would have been desirable to have longer bolthole lengths (higher l/d) in the test specimens since they would have been more representative of those in critical rotating disks. However, higher l/d boltholes would have made it very difficult to produce a crack that extended through the entire length of the hole by cyclical bending. A deeper bolthole would also have been more effectively inspected by the semiautomated scanner since precise control of probe feed rate and translation velocity would have been critical to a

successful inspection. Tooling fabricated earlier was used to precisely and repeatably locate test specimen boltholes in a simulated disk pattern (see figure 5).

The United States Air Force bolthole set, FML100146, contained low-cycle fatigue cracks with a nominal 2:1 surface length to depth ratio. The set consisted of 50 titanium 6-2-4-6 specimens containing 44 cracks with surface lengths ranging from 0.012" to 0.050". Ten of the specimens did not contain any fatigue cracks.

The calibration reference standard contained four EDM notches. Three corner notches of sizes 0.003", 0.006", and 0.009" were used, along with one 0.030" long by 0.015" deep notch in the bolthole center. The notches were separated by 90 degrees around the bolthole. Only the 0.030" long by 0.015" deep center notch was used for the PoD tests to reduce the number of inspection repetitions. Calibrations were optimized in phase and amplitude for each translation run using a 0° probe angle.

The scanning equipment consisted of a Rohman Elotest B1-SDM/UC Version 5.11 instrument with a SR1-HF 96.1.610 probe rotator (1200 rpm). Instrument filters were identical for all inspections to eliminate this variable. A Rohman 2-MHz unshielded reflection differential, 0.040" diameter coil in a 0.460" nominal fit probe was used for all tests. Instruments and probes selected for this study were considered typical for commercial aviation inspection, although their use does not imply endorsement of a particular product. Teflon tape, although commonly used during production inspections to minimize probe wear during calibration and inspection, was not applied to the specimen surface during the study evaluation to eliminate any variation due to tape wear throughout a run.

Eddy-current amplitude, clock position, and depth position (top, middle, or bottom) were recorded for all crack indications. In addition, an average noise level was estimated for each run. Clock position was previously documented with respect to an indent on one of the specimen faces. Reported indications were verified to determine whether they were hits from any of the known cracks, or false calls. The results indicated only one false call was reported during all of the tests.

A missed call on a larger size crack occurred with the semiautomated scanner on a specimen that had two cracks, one at the top and one at the bottom of the hole. The inspector reported the first crack but, for some unknown reason, did not report the second crack. This miss illustrated a limitation of current instrumentation when it was used with a fixtured inspection such as the semiautomated scanner. With the Y-T or amplitude-time display, an indication can appear split between the start and end of the display screen. If this occurs during manual inspection, the inspector would simply twist the rotator until the indication shifted to the middle of the display. However, this manipulation of the signal is not possible with the semiautomated system since the rotator is fixtured for proper alignment. Addition of an electronic adjustment that would change the rotator zero position would eliminate this potential problem. This would avoid the split-signal occurrence in fixtured inspections, but would also allow an inspector testing in the manual mode to hold the rotator in a preferred position and then adjust the zero circumferential reference start, or 0° point. An alternative solution would be to display more than 360° of inspection angle so that the entire signal would always be visible.

3.6 PROCESS CAPABILITY RESULTS.

Both manual and semiautomated technique capabilities exceeded the program metrics. The semiautomated scanner provided a 30% improvement in the 90/50 and 90/95 PoD flaw sizes and almost a factor of 2 improvement in SNR over manual inspection of titanium 6-2-4-6 boltholes, as shown in table 5. The SNR was estimated by dividing the signal amplitude response from the defect by the average baseline noise observed during the tests.

TABLE 5. COMPARISON OF THE MANUAL AND SEMIAUTOMATED HSBH INSPECTION RESULTS TO THE PROGRAM METRIC

	Length 90/50 and 90/95 CL (mils)	SNR
Program metric	30	4:1
Manual scanner	14/17	>7.5:1
Semiautomatic scanner	10/12	>12.5:1

A PoD analysis was completed for each inspector for both manual and semiautomated inspection [5]. The analysis indicated that the PoD capability for every inspector was improved through the use of the semiautomated scanner. The analytical method is based on the PoD methodology developed at the University of Dayton, Research Institute. The PoD data in figures 6 and 7 represent a total of eight manual and eight semiautomated PoD inspection runs by four inspectors and includes a total of 352 crack detection opportunities.

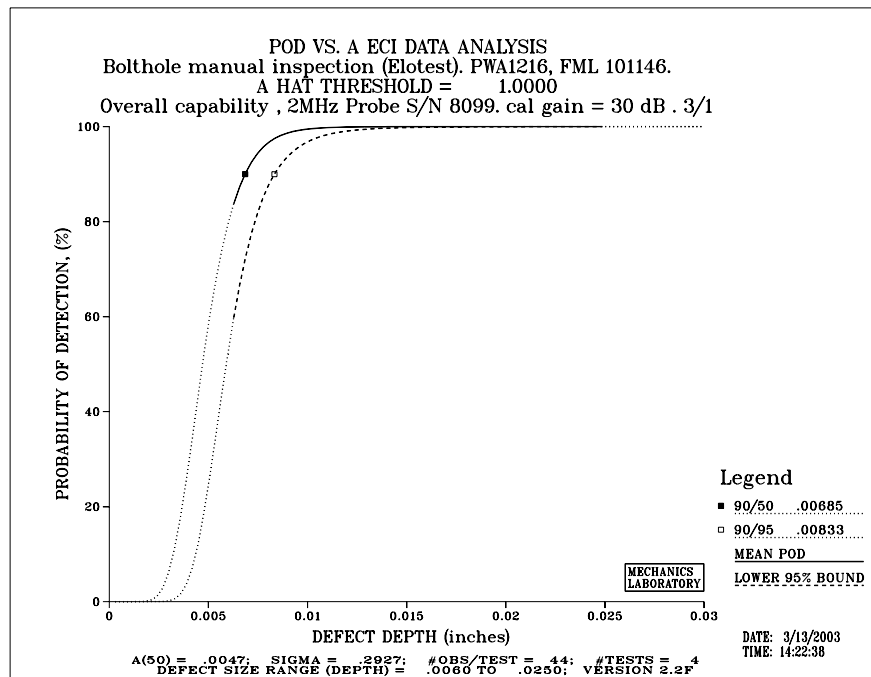

FIGURE 6. OVERALL PoD RESULTS FOR HSBH INSPECTION USING MANUAL SCANNER

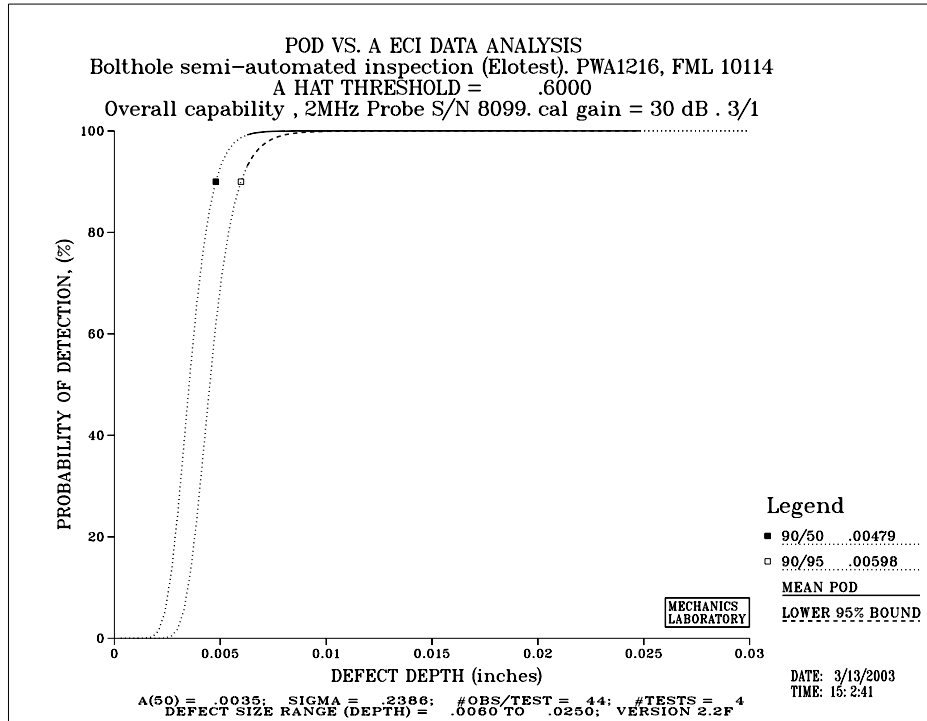

FIGURE 7. OVERALL PoD RESULTS FOR HSBH INSPECTION USING SEMIAUTOMATED SCANNER DEVELOPED UNDER THIS EFFORT

4. CONCLUSIONS.

High-speed bolthole (HSBH) eddy-current inspection has emerged as the leading inspection technique for fast and accurate inspection of circular air- and boltholes. This study investigated the main sources of variation in the HSBH inspection process by designing and conducting a three-factor, two-level design of experiments (DOE) study.

A semiautomated scanner prototype was designed and manufactured to minimize variations in the inspection process, as identified by the DOE. This scanner and associated fixturing were then tested to evaluate the process capability and reliability compared to a current manual field technique. Both the manual and semiautomated inspection techniques successfully exceeded the program metric of demonstrating the capability to detect a 0.030" long crack at a 4:1 signal-to-noise ratio in a common bolthole geometry.

Probability of detection curves were prepared for both techniques using titanium 6-2-4-2 bolthole test specimens containing fatigue cracks ranging in length from 0.012" to 0.050". The semiautomated scanner showed about 30% improvements in the 90/50 flaw size (0.010" versus 0.014") and the 90/95 flaw size (0.012" versus 0.017") over the manual inspection method. All data was obtained using experienced eddy-current inspectors and relatively shallow (0.250" deep) bolthole crack specimens.

Scanner reliability tests resulted in a written inspection technique that was jointly used by the original equipment manufacturers and served to further standardize the inspection process. Information gained during this process was used to draft a best practices proposed revision of the industry specification, SAE AS4787, “Eddy-Current Inspection of Circular Holes in Nonferrous Metallic Hole Inspection in Aircraft Engines.”

5. REFERENCES.

1. SAE Aerospace Standard – AS4787 Issued 1992-10 and Reaffirmed 1996-07, “Eddy Current Inspection of Circular Holes in Nonferrous Metallic Aircraft Engine Hardware.”
2. Burkel, R.H., Chiou, C.-P., Keyes, T.K., Meeker, W.Q., Rose, J.H., Sturges, D.J., Thompson, R.B., and Tucker, W.T., “A Methodology for the Assessment of the Capability of Inspection Systems for Detection of Subsurface Flaws in Aircraft Turbine Engine Components,” FAA report DOT/FAA/AR-01/96, September 2002.
3. Margetan, F.J., Gigliotti, Brasche, L., and Leach, W., “Fundamental Studies: Inspection Properties for Engine Titanium Alloys,” FAA report DOT/FAA/AR-02/114, December 2002.
4. Design and Analysis of Experiments, 5th edition, by Douglas C. Montgomery.
5. Berens, A.P. and Hovey, P.W., “Flaw Detection Reliability Criteria, Volume 1—Methods and Results,” AFWA:-TR-84-4022, April 1984.

APPENDIX A—MAIN EFFECTS AND INTERACTION PLOTS GENERATED IN THE DOE STUDY DESIGNED TO DETERMINE THE IMPORTANT PARAMETERS USED IN HSBH INSPECTION

A three- factor, two-level full factorial design (two^{*} or eight combinations) blocked for motor speed and randomized within each block design of experiment (DOE) was selected as the tool to measure the high-speed bolthole process sensitivity. The DOE design and summary results were discussed in this report. In this appendix, the data generated in this study are presented for completeness. All charts were generated using Minitab™, a comprehensive statistical and graphical analysis software package. The following is an explanation of charts that appear in the appendix and could be used as guidance in the interpretation of these figures.

- Pareto Chart of Effects. The Pareto chart illustrates both the magnitude and the importance of an effect. This chart displays the absolute value of the effects and draws a reference line on the chart. Any effect that extends past this reference line is potentially important. Minitab displays the
 - absolute value of the unstandardized effects when there is not an error term.
 - absolute value of the standardized effects when there is an error term.
- Cube Plot. Cube plots in a DOE study can be used to show the relationship between up to eight factors, with or without a response measure. Viewing the factors without the response illustrates what a design looks like. If there are only two factors, Minitab displays a square plot. One can draw a cube plot for one of the following:
 - data means—the means of the raw response variable data for each factor level.
 - fitted means after analyzing the design—predicted values for each factor level.

The plots in the appendix illustrate a three-factor cube plot without a response variable. These factors are probe angle, probe rotation speed, and probe feed rate. The range of these factors is also indicated on the figure.

- Main Effects Plot. The main effects plot is used to plot data means with multiple factors. The points in the plot are the means of the response variable at the various levels of each factor, with a reference line drawn at the grand mean of the response data. The main effects plot can be used for comparing magnitudes of main effects.
- Interaction Plot. Interactions Plot creates a single interaction plot for two factors, or a matrix of interaction plots for three to nine factors. An interactions plot is a plot of means for each level of a factor with the level of a second factor held constant. Interaction plots are useful for judging the presence of interaction between the various factors. Interaction is present when the response at a factor level depends upon the level(s) of other factors. Parallel lines in an interaction plot indicate no interaction. The

* Berens, A.P. and Hovey, P.W., “Flaw Detection Reliability Criteria, Volume 1—Methods and Results,” AFWA:-TR-84-4022, April 1984.

greater the departure of the lines from the parallel state, the higher the degree of interaction. To use the interactions plot, data must be available from all combinations of levels.

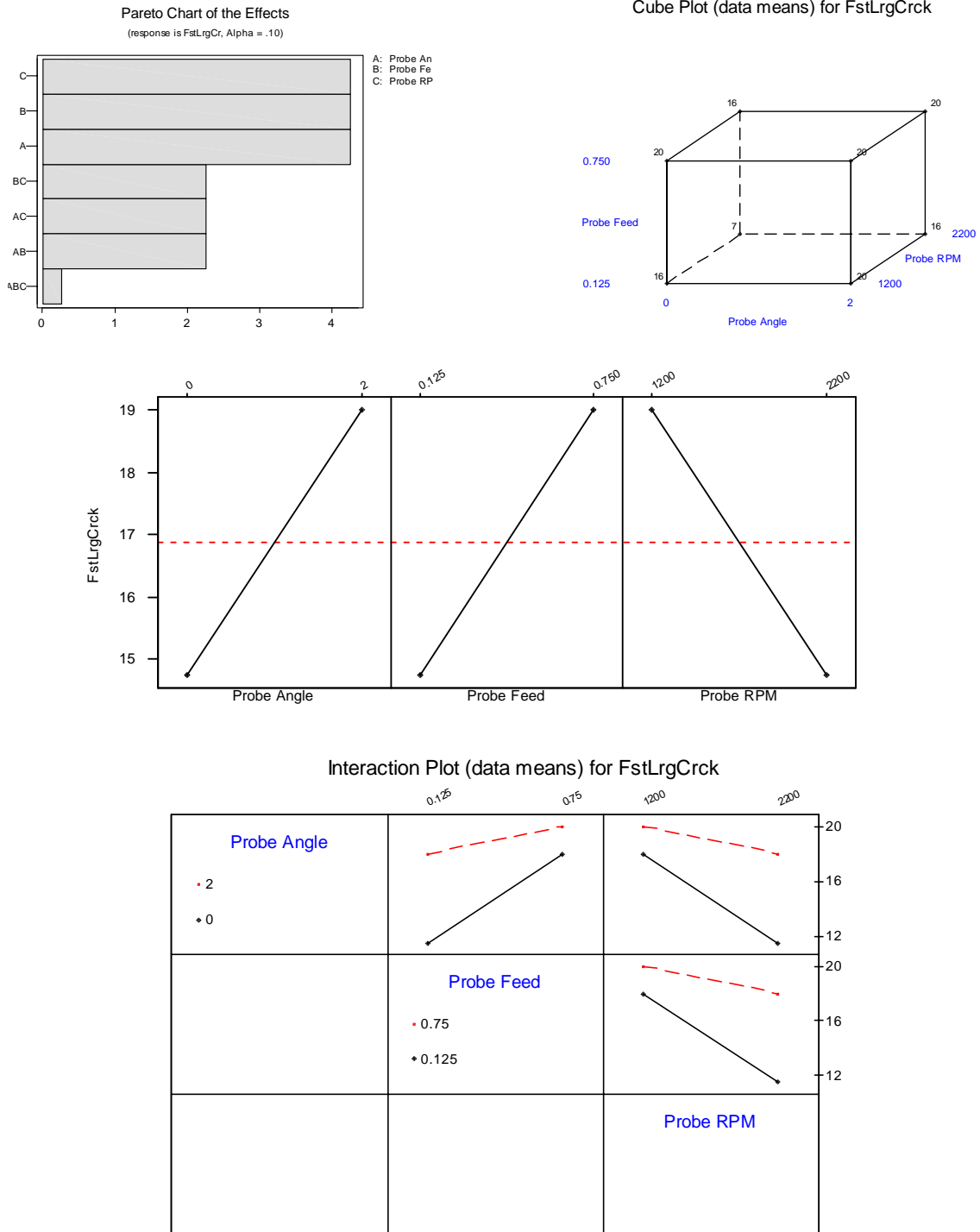

FIGURE A-1. LARGEST CRACK MISSED RESULTS

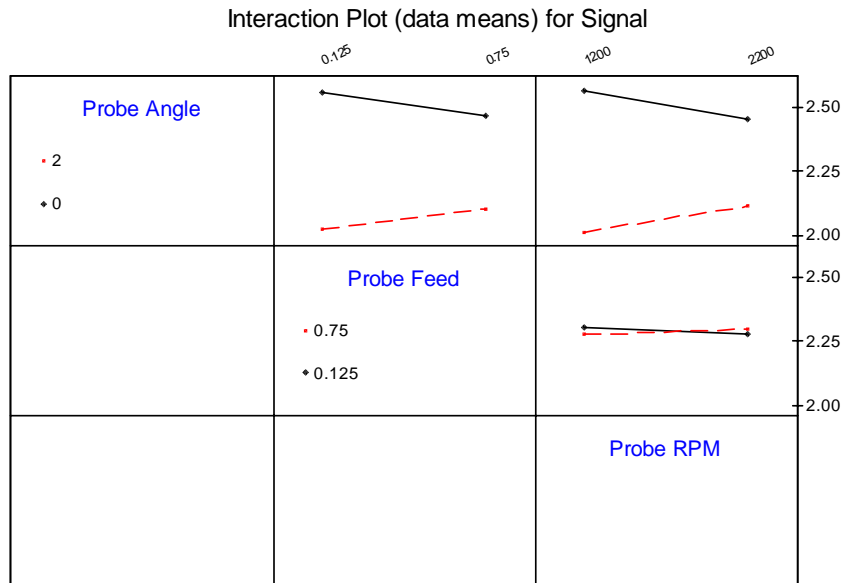
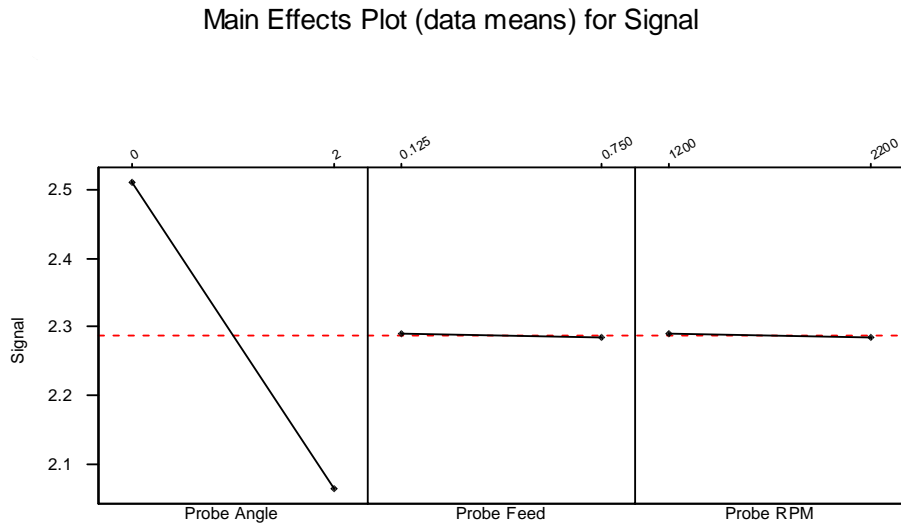
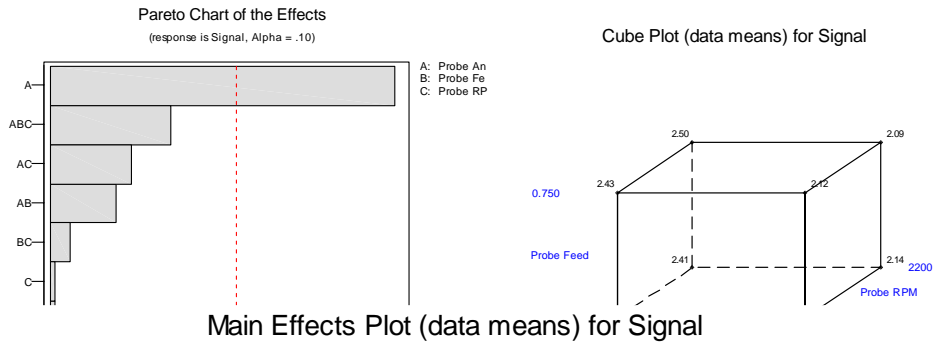
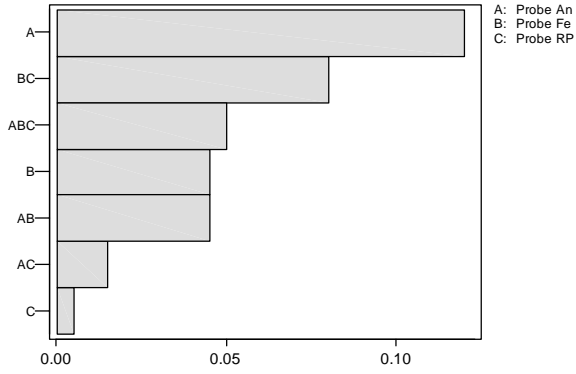

FIGURE A-2. SIGNAL AMPLITUDE RESULTS

Pareto Chart of the Effects

(response is HighNois, Alpha = .10)



Cube Plot (data means) for HighNoise

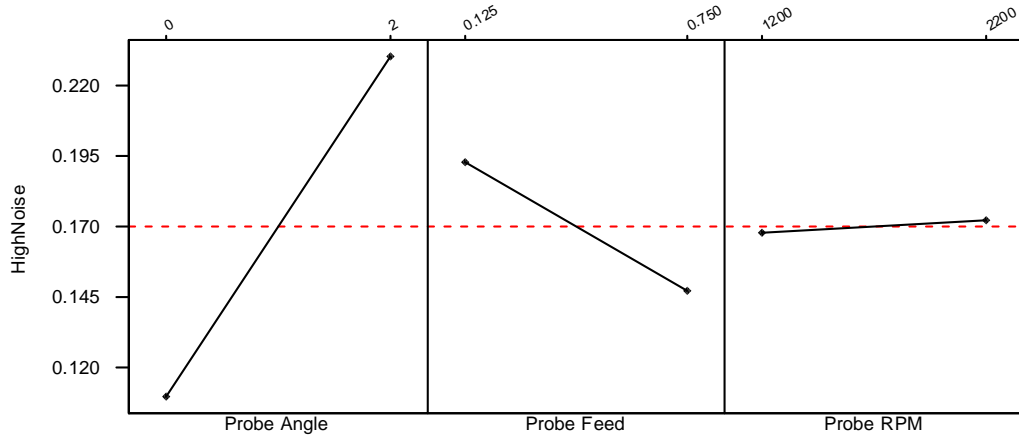
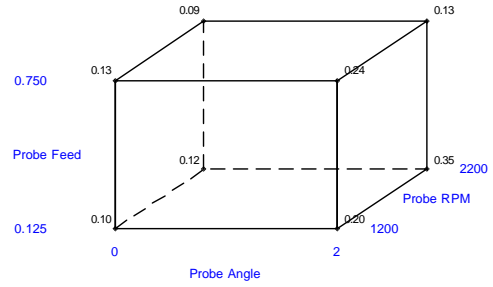

Interaction Plot (data means) for HighNoise

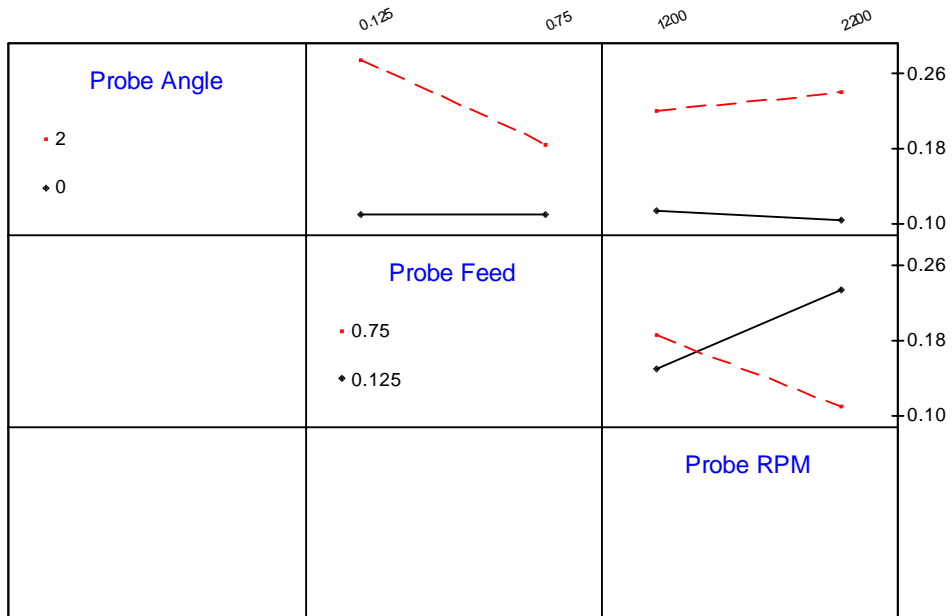
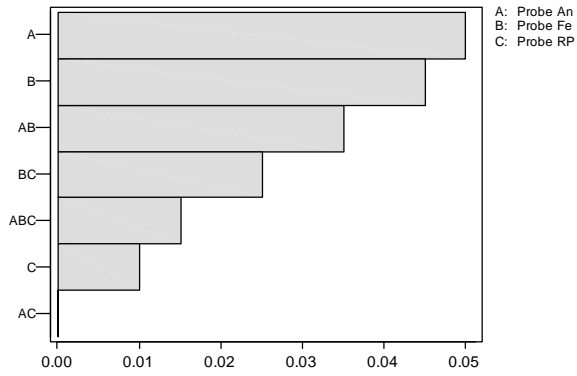
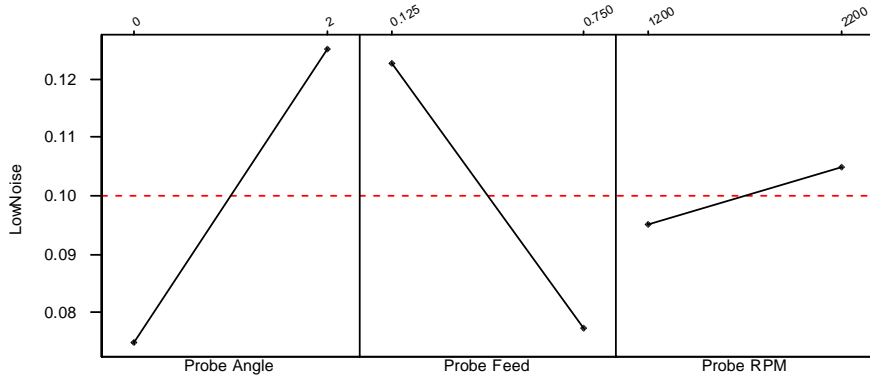
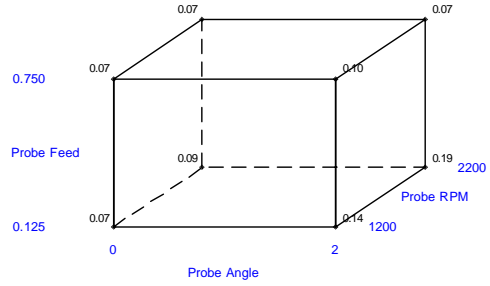

FIGURE A-3. HIGH-NOISE RESULTS

Pareto Chart of the Effects
(response is LowNoise, Alpha = .10)



Cube Plot (data means) for LowNoise



Interaction Plot (data means) for LowNoise

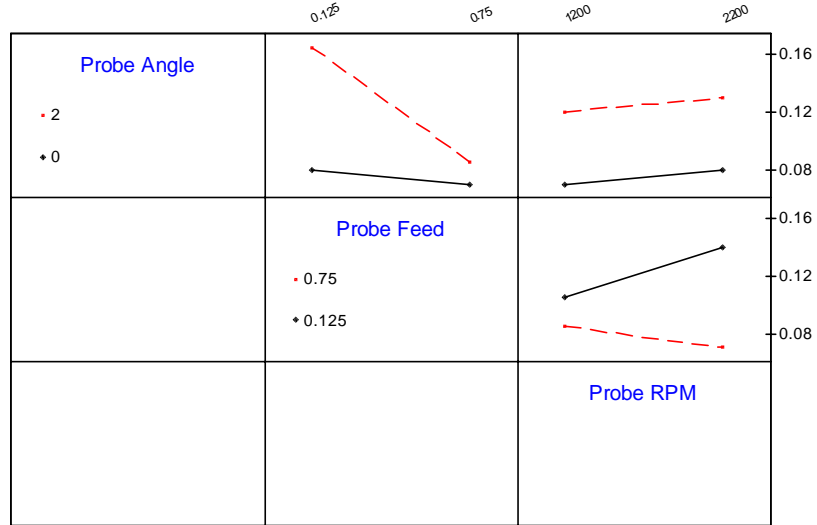
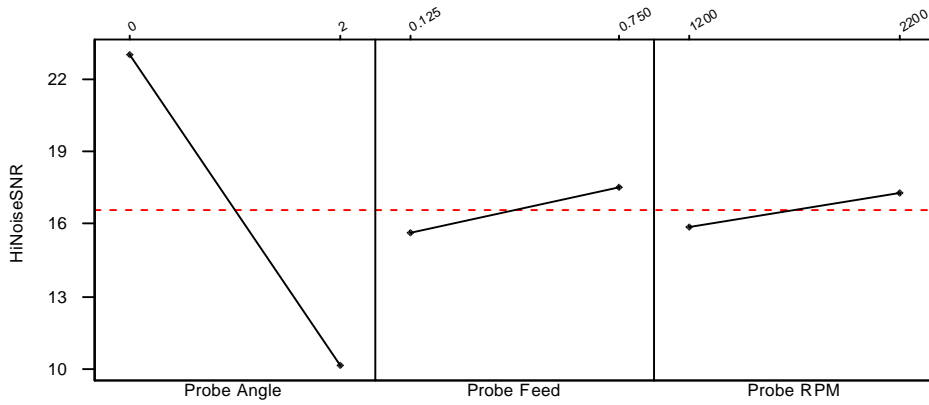
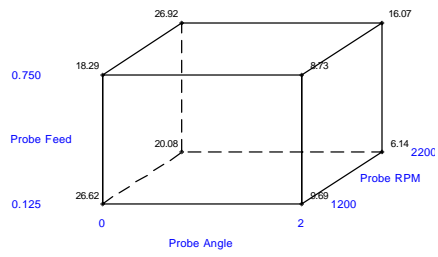
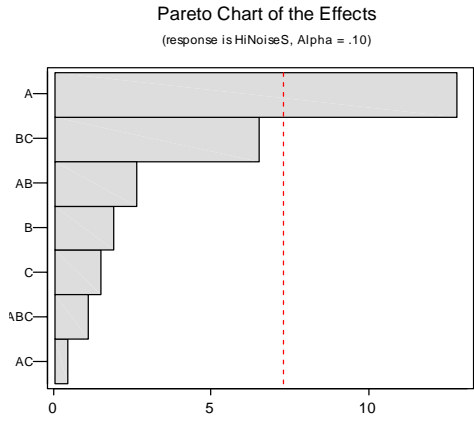

FIGURE A-4. LOW-NOISE RESULTS

Cube Plot (data means) for HiNoiseSNR



Interaction Plot (data means) for HiNoiseSNR

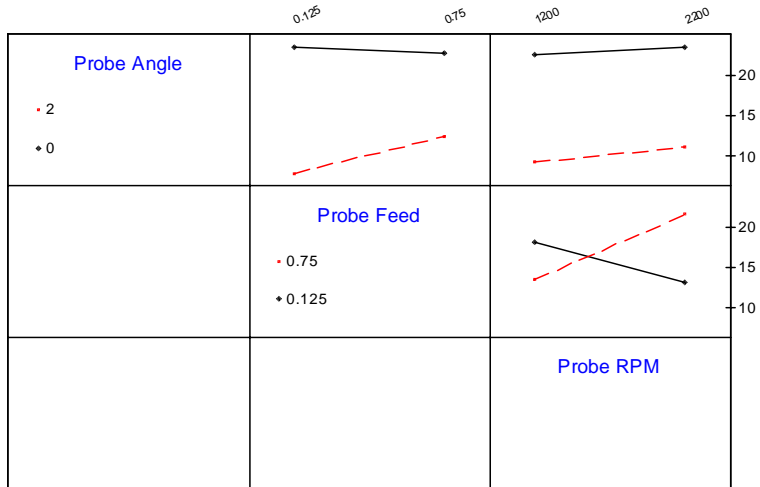

FIGURE A-5. HIGH-NOISE SNR RESULTS

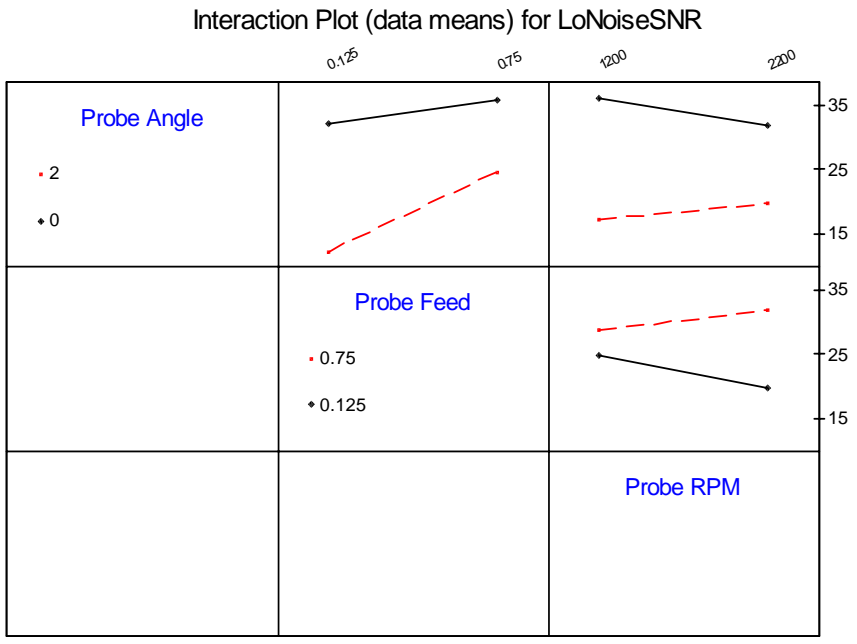
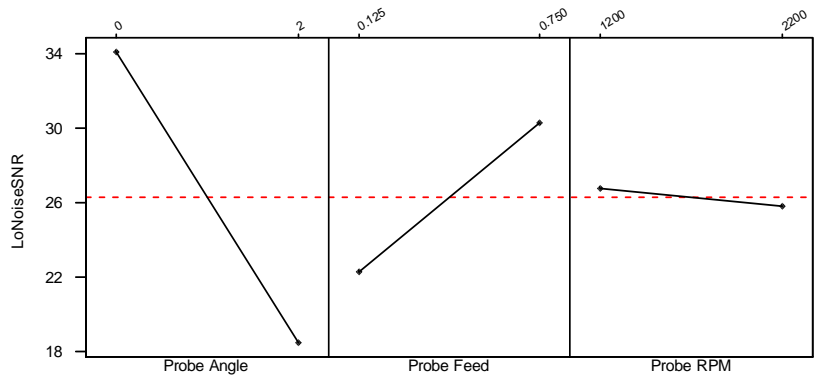
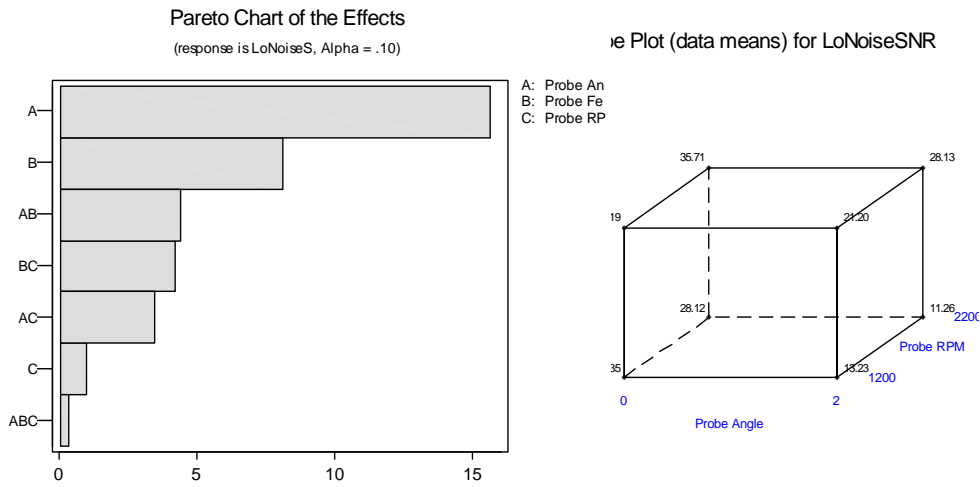

FIGURE A-6. LOW-NOISE SNR RESULTS

APPENDIX B—DESIGN DRAWINGS FOR THE COMMON TOOLING AND FIXTURES

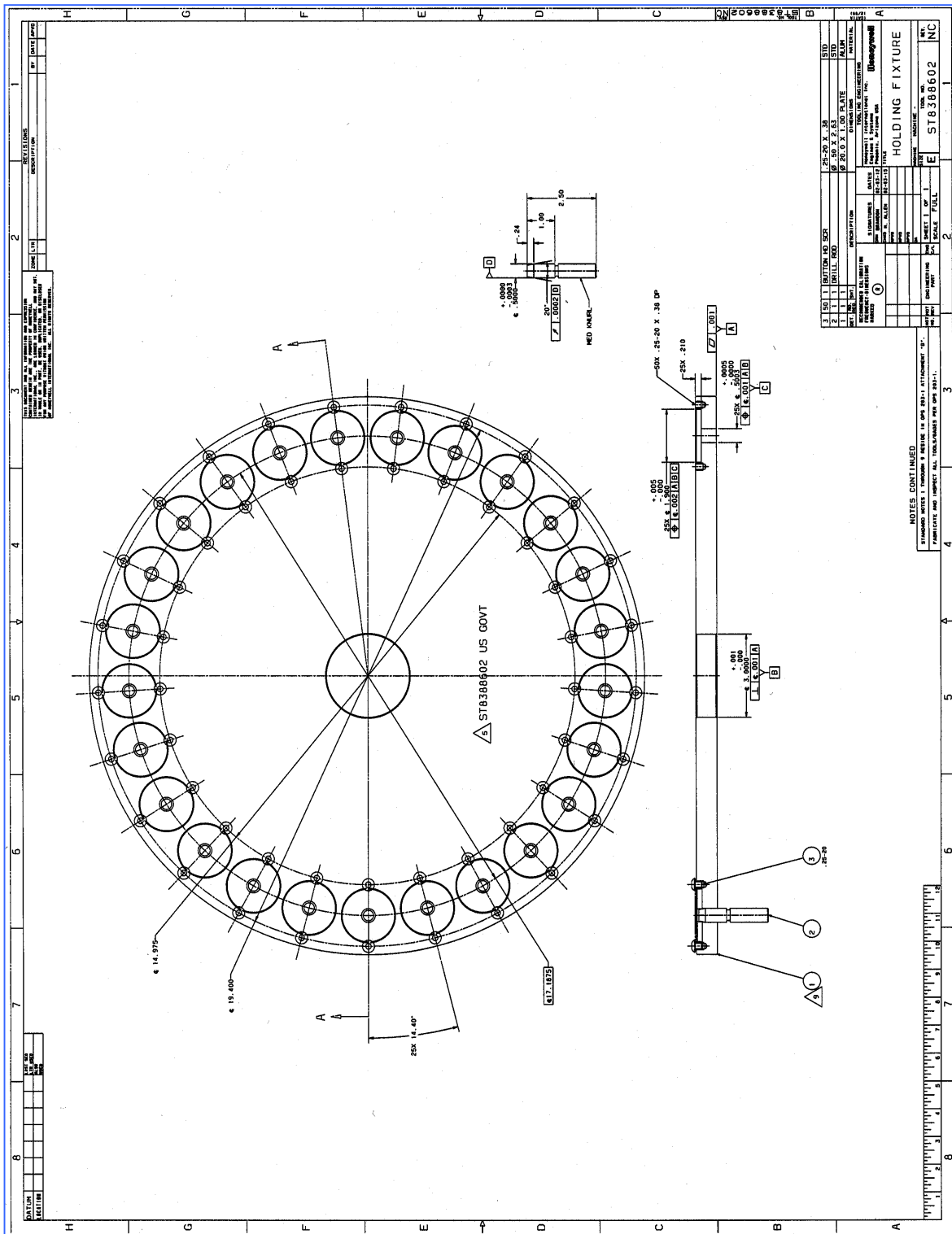
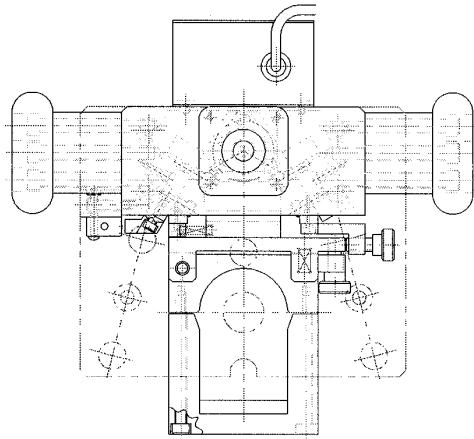
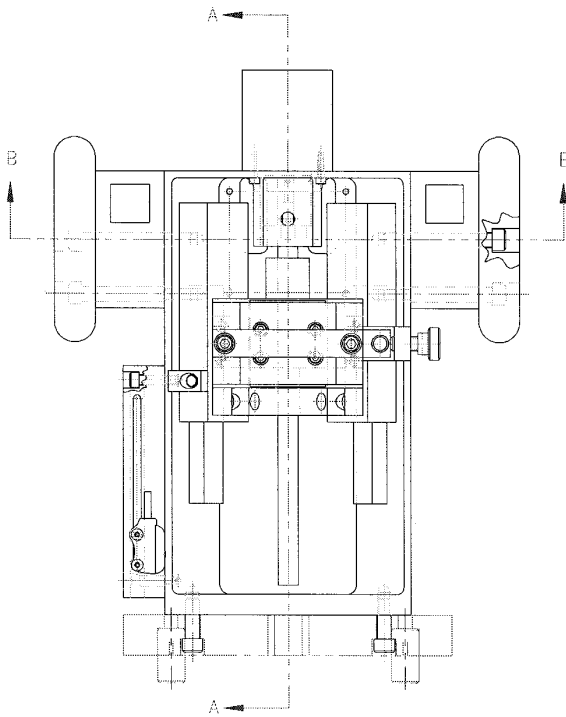

FIGURE B-1. BOLTHOLE SPECIMEN SIMULATOR FIXTURE



Top



Front

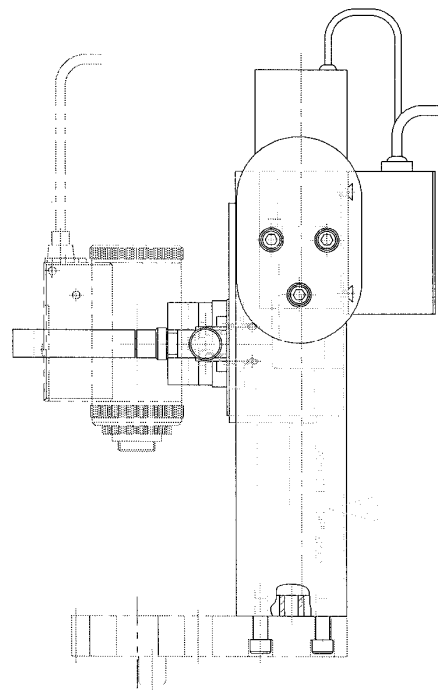

Side

FIGURE B-2. SEMIAUTOMATED SCANNER DESIGN

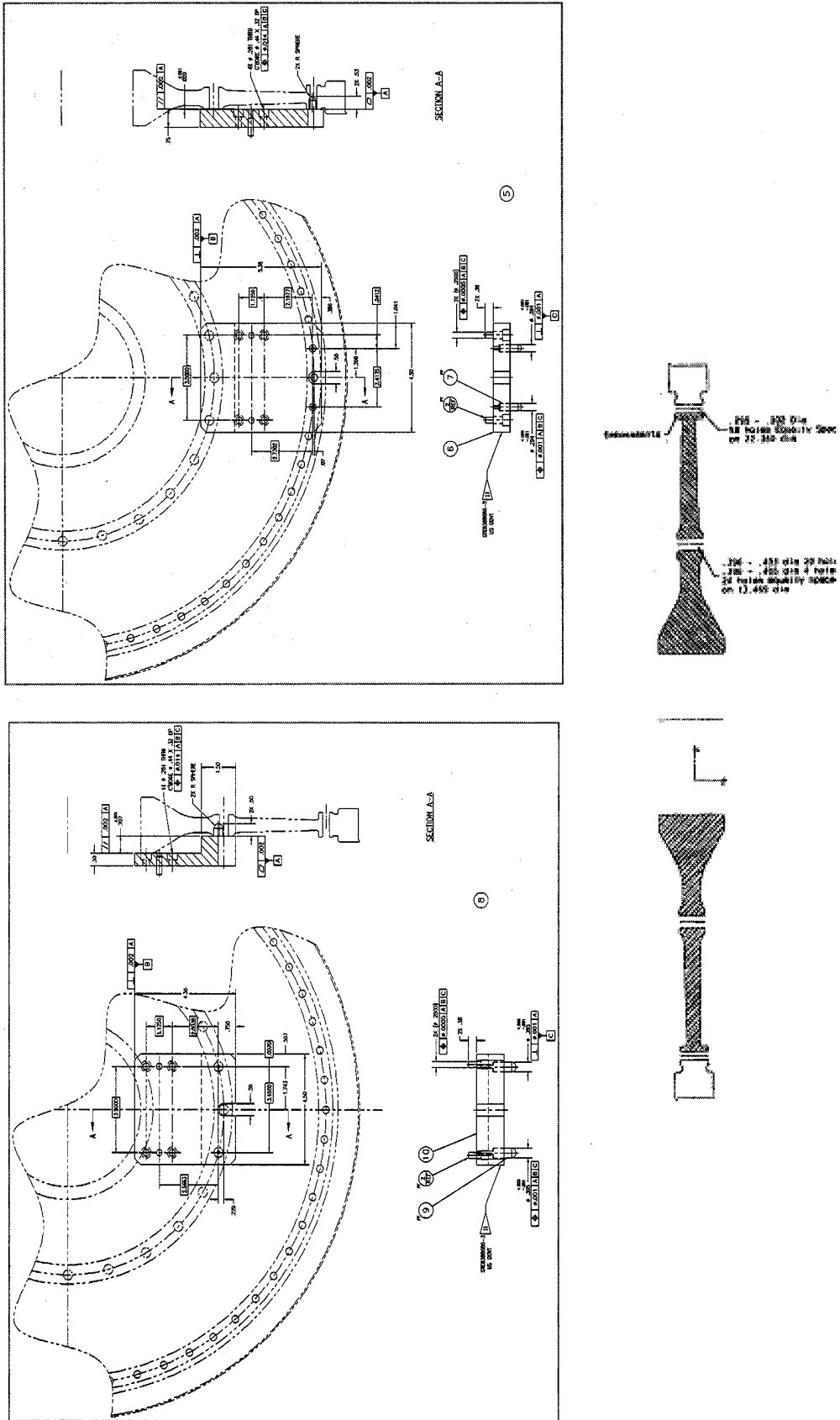

FIGURE B-3. ADAPTER PLATES DESIGN FOR GE DISK USED IN DEMONSTRATING THE INSPECTION TECHNIQUE ON ACTUAL ENGINE HARDWARE ALONG WITH A SCHEMATIC OF THE DISK CROSS SECTION

APPENDIX C—PROBABILITY OF DETECTION INSPECTION TECHNIQUE AND
DATA COLLECTION SHEET

**ETC Subtask 2.2.2
HIGH SPEED BOLTHOLE EDDY CURRENT
SCANNING**

**POD TESTING INSTRUCTIONS FOR CAPABILITY
TESTING OF SEMI-AUTOMATED BOLTHOLE
SCANNER P/N STE8388601**

21-1

March 08, 2003

ETC SUBTASK 2.2.2

HIGH SPEED BOLTHOLE EDDY CURRENT SCANNING

21-1 March 08, 2003

Prepared by: Andy Kinney
ET Level III

Approved by: Rob Stephen
ETC 2.2.2 Team Rep.

REPORT NO. 21-1

TOTAL PAGES 8

ATTACHMENTS:

REV	BY	APPROVED	DATE	PAGES AFFECTED
1	AK		2002-12-20	All
2	AK		2003-02-04	1,3,5,6,7
3	AK		2003-03-08	8

ETC SUBTASK 2.2.2

HIGH SPEED BOLTHOLE EDDY CURRENT SCANNING

1.0 SCOPE

This procedure uses high-speed eddy current bolthole scanning to inspect and record results from the POD specimen testing set FML 101146 using manual (fixtured & handheld calibrations), semi-automated (ETC 2.2.2 scanner P/N ST8388601), and automated scanning (ETC2000).

2.0 PERSONNEL QUALIFICATION

Personnel performing these inspections shall be certified to a minimum of Level II in eddy current per NAS-410 requirements with previous eddy current bolthole inspection experience.

3.0 EQUIPMENT

Instrument: The eddy current instrument used for manual and semi-automated scanning shall be the Rohmann Elotest B1-SDM/UC Version 5.11 instrument. Automated scanning will use the ETC2000 scanner and data acquisition.

Equipment:

Manual Un-fixtured Inspection-Rohmann Elotest probe rotator SR1-HF 96.1.610 (1200 rpm)

Manual Fixtured Inspection-GEAE fixture PN 8047G01 and Rohmann Elotest probe rotator SR1-HF 96.1.610 (1200 rpm)

Semi-Automated Inspection-ETC Scanner P/N STE8388601 and Rohmann Elotest probe rotator SR1-HF 96.1.610 (1200 rpm)

Automated Inspection-ETC2000 Scanner and Uniwest probe rotator ETC-5037 (1500 rpm)

Probes: Rohmann P/N R&MS2/0.460 Diameter 0.46 inches

Reference Standard: Marked titanium 6-2-4-6 standard having a bolthole diameter 0.460" and 0.030" long x 0.015" deep EDM notch.

Specimen Fixturing: The POD specimen set will be fixtured in adapter plate STE8388602 that holds 24 specimens plus the calibration standard. The semi-auto

scanner shall use the flat adapter plate, P/N STE838860-1 mounted for calibration and inspection.

4.0 PROBE PREPARATION

The test probe shall utilize a split-core differential coil that is nominally flush with the probe.

5.0 INSPECTION PROCEDURE

Complete the Figure C1 calibration record sheet for each set of pre, post, and any additional calibrations occurring during one specimen POD run set. A run set is defined as a complete inspection of all 50 POD specimens by one inspector for a particular technique, either manual or semi-automated scanner.

Set inspection instrument parameters as follows:

Frequency: 2 MHz

Phase: Set instrument phase while in the impedance plane (X-Y) display to maximize the vertical response (Y) of the calibration notch. Initial setting is 132 degrees.

Gain: The Elotest B1 pre-amp shall be set to 30 dB. Initial gain shall then be set such that the response from the 0.030" L x 0.015" Dp EDM notch is 7.5 screen divisions.

Probe Rotator Rate:

1200 rpm - Rohmann Elotest probe rotator SR1-HF 96.1.610

1500 rpm - Uniwest probe rotator ETC-5037

Display: A time sweep (Y-T) display shall be used for inspection. The X-Y impedance plane display shall be used for probe centering and phase adjustment off the EDM calibration notch.

Filter: Low-pass and hi-pass filtering shall be used to decrease unwanted noise. The filters are correctly set up when the response from the notch target shows as a distinct, sharply peaked 'W' shaped sinusoidal signal about the horizontal centerline (see Figure C2).

Alarm Gate: No alarms are to be used for POD testing.

Translation Rate or Index:

Manual – typical rate for bolthole testing

Semi-automated – 0.1 inches/sec setting

Full-automated – 0.008” index (equivalent to a 0.2 inches/sec helical scan at 1500 rpm)

FIGURE C1. EDDY CURRENT POD CALIBRATION RECORD

Facility: XXX		Date:
ET Inspector Identification (Circle One): A B C D		Time(Start):
Specification: Engineering Report 21-1		Time(Finish):
Eddy Current Instrument Mfg, Model & Ver.: Rohmann Elotest B1-SDM/UC Version 5.11		
Equipment Mfg.and Model: Elotest SR1-HF 96.1.610 probe rotator; ETC P/N STE8388601(Semi) & ETC2000 with (Full Auto)		
Probe Mfg./Part No.: Rohmann		Probe S/N:
Gain: (preamp 30dB) + dB gain		Frequency: 2 MHz
Display: Sweep Y-T	V/H: Probe Centering Only	Filters: HP _____ LP _____ Filters: HP <u>200</u> LP <u>800</u>
Alarm: Manual-N/R Semi-auto- ± 1 Div. Audible: On for semi	Translation Rate: 0.1"/sec Semi-automatic 0.008" index Automatic	Probe rotator RPM: Elotest 1200 Uniwest 1500
Calibration Sensitivity: 0.030" L x 0.015" Dp EDM notch to 7.4 Divisions		
Alarm Level: Not used for manual inspections; ± 1 Division for Semi-Auto		
Reject Level: Any crack indication		
Post cal. • Y N		
Circle One: Manual-Unfixtured Manual-Fixtured Cal. Semi-Auto Inspection Automated Inspection		
Calibration Files Pre: _____ Mid: _____ Post: _____		

6.0 REFERENCE STANDARD CALIBRATION

Adjust instrument per section 5.0.

Teflon tape shall not be applied for calibration or for inspection of the POD set.

Center the probe as follows:

- Visually align probe over bolthole.
- Turn filters off and place instrument in XY plane mode
- Rotate probe down into the calibration standard away from notches
- Minimize excursion of the flying dot using fixture adjustment wheels
- Place instrument in YT trace mode, set up instrument filters, and make any final fine adjustments to reduce noise.

Calibrate the inspection system on the 0.030” long x 0.015” deep EDM notch to 7.5 divisions on the calibration standard using either the semi-automated or automated fixturing. Print out and label a pre-calibration report when using the Elotest B1.

Refer to and complete an **Eddy Current POD Calibration Record** (separate copies available) including: Inspection date, start time, assigned inspector I.D., probe P/N, probe S/N, calibration gain, filter settings, inspection type (manual, semi-auto, auto.), calibration file(s) or pre-cal print-out.

The display of the reference standard notch should be as shown in Fig. C2. when filter settings are set as follows:

Set the high-pass filter to 200 Hz to produce a more symmetrical “W” shape from the calibration notch. Set the low-pass filter to 800 Hz to eliminate any high frequency spikes without significantly reducing signal amplitude to produce the best signal-to-noise ratio.

Verify that all parameters are correctly set and recorded before proceeding.

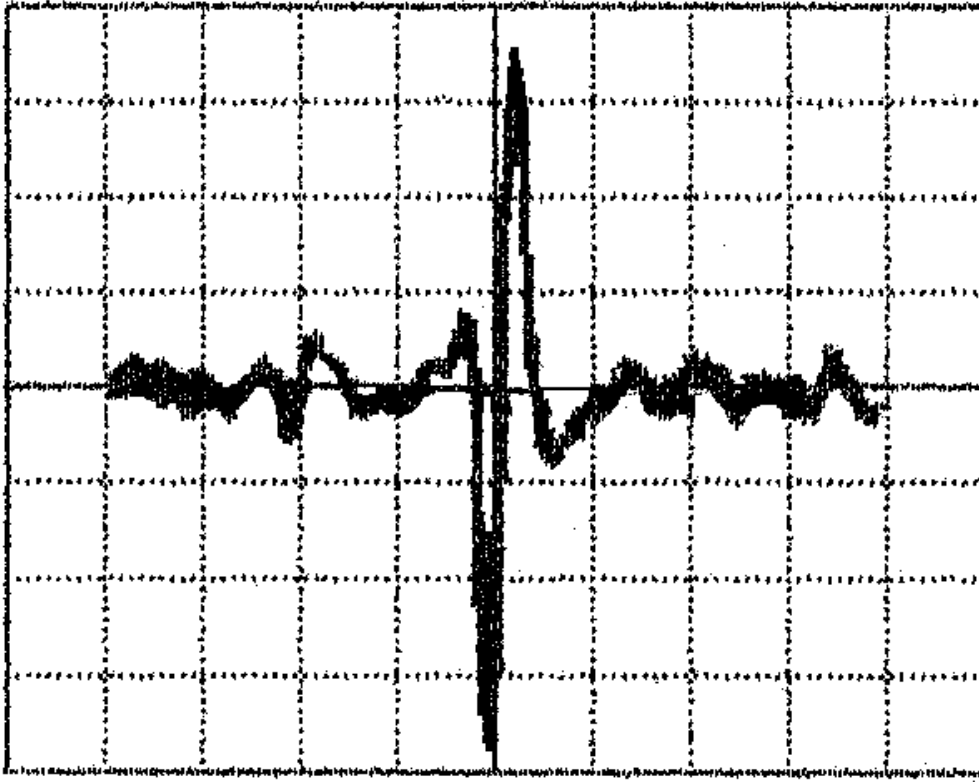

FIGURE C2. CALIBRATION STANDARD 0.030 X 0.015 RESPONSE

7.0 SPECIMEN SCANNING

Calibrate per Section 6.

For manual inspection of the POD specimens, the rotator will be hand held. Use the ETC scanner P/N STE8388601 for semi-automated scanning. Use the ETC 2000 scanner for fully automated scanning.

Scan the POD specimens to detect cracks.

Indications shall be peaked out to determine if they exceed two (2) screen divisions. For indications exceeding two (2) divisions, record amplitude and the temporary specimen I.D. For indication amplitudes greater than full screen, reduce the preamp gain by 6dB or 12 dB, whichever results in the highest on-screen signal. Record preamp gain. **Return instrument preamp setting to 30dB.**

8.0 POST CALIBRATION CHECK

After inspecting the POD set, check and record post calibration. Print out and label a pre-calibration report when using the Elotest B1. Print out and label a post-calibration report showing the calibration standard peak amplitude. If the amplitude repeats within 5 minor divisions of the precalibration run, the test is acceptable. If the amplitude of the EDM notch has fallen outside this range, check probes fit, and repeat calibration check. See the POD test proctor for possible re-inspection of all specimens since the last valid calibration if the calibration is still invalid.

Complete a **Figure 1C Eddy Current POD Calibration Record** by circling the post calibration check and finish time.

9.0 EVALUATION

Peak out and record amplitude and temporary specimen identity for any indication greater than two (2) major screen divisions using the eddy current POD recording sheet provided below. In addition for signals greater than full screen, also record the pre-amplifier gain used to bring indication on screen. **Return instrument preamp setting to 30dB.**

10.0 ACCEPTANCE CRITERIA

Reject any relevant indication. A relevant indication is any repeatable indication with greater than a 2:1 signal-to-noise ratio.

Data will later be analyzed to determine the Probability of Detection (POD). Inspector identity will remain confidential.

APPENDIX D—DRAFT REVISION OF INDUSTRY STANDARD AS4787

*The Engineering Society
For Advancing Mobility
Land Sea Air and Space®*
INTERNATIONAL

400 Commonwealth Drive, Warrendale, PA 15096-0001
Submitted for recognition as an American National Standard
Issued 1992-10

AS4787

AEROSPACE STANDARD

Draft

EDDY CURRENT INSPECTION OF CIRCULAR HOLES IN NONFERROUS METALLIC AIRCRAFT ENGINE HARDWARE

TABLE OF CONTENTS

1. SCOPE	3
1.1 Purpose	3
1.2 Application	3
1.3 Definitions	3
2. APPLICABLE DOCUMENTS	3
2.1 U.S. Government Publications	3
2.2 ASNT Publications	4
2.3 ATA Publications	4
3. TECHNICAL REQUIREMENTS	4
3.1 Materials	4
3.1.1 Tape	4
3.1.2 Cleaning Materials	4
3.1.3 Marking Devices	4
3.2 Equipment	4
3.2.1 Eddy Current Probes	4
3.2.2 Eddy Current Instruments	5
3.2.3 Mechanical Probe Manipulation Devices	9
3.2.4 Data Recording Devices	9
3.2.5 Calibration Standards	9
3.3 Personnel Qualification	10
3.4 Inspection Procedure Requirements	10
3.5 Part Preparation for Inspection	12
3.6 Equipment Calibration - Manual Probe Manipulation	12
3.7 Equipment Calibration - Mechanical Probe Manipulation	13
3.8 Part Inspection - General Requirements	14
3.9 Posttest Calibration Check	14
3.10 Indication Evaluation	15

TABLE OF CONTENTS (Continued)

4. QUALITY ASSURANCE 15

4.1 Records. 15

4.2 Facilities/Equipment 16

4.3 Calibration Standards 16

4.4 Inspection Procedures. 16

4.5 Quality Assurance Plans 16

4.6 Calibration System 16

FIGURE 1 Typical Eddy Current Probe 6

FIGURE 2 Eddy Current Displays. 7

FIGURE 3 Eddy Current and Meter Displays 8

FIGURE 4 Typical Calibration Standard 11

EDDY CURRENT INSPECTION OF CIRCULAR HOLES IN NONFERROUS METALLIC AIRCRAFT ENGINE HARDWARE

1. SCOPE:

1.1 Purpose:

This SAE Aerospace Standard (AS) establishes minimum requirements for eddy current inspection of circular holes in nonferrous, metallic, aircraft engine hardware with fasteners removed. The inspection is intended to be performed at maintenance and overhaul facilities on engine run hardware.

1.2 Application:

This standard has been typically used to inspect for service-induced surface and near surface cracks, but usage is not limited to such applications.

1.3 Definitions:

1.3.1 PURCHASER: The organization that issued the procurement document invoking this specification.

1.3.2 SUPPLIER: Source, other than the purchaser, who provides inspection services.

1.3.3 INSPECTION PROCEDURE: Document written by the purchaser detailing inspection requirements.

1.3.4 QUALITY ASSURANCE PLAN: Document written by the supplier outlining specific requirements unique to his/her facility in accordance with inspection procedure.

2. APPLICABLE DOCUMENTS:

The following publications form a part of this specification to the extent specified herein. The applicable issue of referenced publications shall be the issue in effect on the date of the purchase order.

2.1 U.S. Government Publications:

Available from DODSSP, Subscription Services, Building 4D, 700 Robbins Avenue,
Philadelphia,
PA 19111-5094.

~~MIL-I-23594A-A-59474~~ Insulation Tape, Electrical, High Temperature, Polytetrafluoroethylene, Pressure Sensitive

~~MIL-STD-410 Nondestructive Testing Personnel Qualification and Certification (Eddy Current, Liquid Penetrant, Magnetic Particle, Radiographic, and Ultrasonic)~~

~~MIL-STD-45662~~

2.2 International Organization for Standardization

Available from ISO1, International Organization for Standardization, Case Postale 56, Geneva, Switzerland Ch-1211

ISO 10012 Calibration System Requirements

2.3 AIA Document:

Available from Aerospace Industries Association (AIA), 1250 Eye St. N.W., Suite 1200, Washington, DC 20005. (www.aia-aerospace.org)

NAS-410 Nondestructive Testing Personnel Qualification and Certification

2.24 ASNT Publications:

Available from ASNT, 1711 Arlington Lane, P.O. Box 28518, Columbus, OH 43228.
SNT-TC-1A Recommended Practice, Personnel Qualification and Certification in Nondestructive Testing

2.35 ATA Publications:

Available from Air Transport Association of America, 1301 Pennsylvania Avenue, N.W., Suite 1100, Washington, DC 20006.
ATA 105 Guidelines for Training and Qualifying Personnel in Nondestructive Testing Methods

3. TECHNICAL REQUIREMENTS:

3.1 Materials:

The high temperature, high speed environment in which many aircraft engine components operate results in an increased sensitivity to mechanical or chemical damage during maintenance activities. Personnel performing eddy current inspections must be aware of the need to ensure that the materials they use which come in contact with the hardware must be carefully chosen to avoid introducing chemical contamination or causing physical damage. Engine manufacturers can provide information regarding the suitability of specific materials or procedures for use on their hardware.

3.1.1 Tape: MIL-I-23594A-A-59474, Type I (smooth backing), Class 3 0.0036 to 0.0045 in (0.08-09 to 0.131 mm) thick. Alternate thicknesses (Class) and alternate tapes may be used if specified in the appropriate inspection procedure.

3.1.2 Cleaning Materials: Mild abrasive cleaning products may be used, if allowed by the purchaser, for the removal of surface contamination. Such products shall not be aggressive enough to remove the base metal or otherwise alter or damage the part. If allowed, mild,

nonmetallic abrasive cleaning pads can be torn in strips or circular nonmetallic brushes may be used to clean the inside diameter of holes. These materials shall be specified in the inspection procedure.

3.1.3 Marking Devices: Approved marking device that are acceptable to the purchaser for numbering part features and identifying the locations of suspect test indications. ~~that are acceptable to the purchaser.~~

3.2 Equipment:

3.2.1 Eddy Current Probes:

3.2.1.1 Select probes based on the minimum diameter of the holes to be inspected. The hole diameter and appropriate probe for any particular inspection shall be as specified in the inspection procedure. Depending on the type of probe, it is recommended that the purchaser consider the hole diameter range for the probe being specified.

3.2.1.2 Absolute (single coil), differential (dual coil), and reflection (driver-pickup) coil configurations, with or without magnetic shielding, shall be used as specified in the inspection procedure. Differential coils are the preferred coil configuration for circular hole inspection and shall be oriented (scanned) normal to the crack direction.

3.2.1.3 Probes shall be designed to maintain contact with the inspection surface at all times during the inspection. Noncontact probes which operate with a gap between the probe and the inspection surface are not acceptable.

3.2.1.4 Probes with operating frequencies of 500 KHz or higher shall be used, unless otherwise specified by the appropriate inspection procedure.

3.2.1.5 All probes shall be identified with the manufacturer's name, frequency or frequency range, and a unique serial number (reference Figure 1).

3.2.1.6 Eddy current probe sensing coils shall be prevented from directly contacting the surface of the part being inspected. This may be accomplished by covering the coil surface with low-friction tape, by recessing the coil from the surface of the probe, by manufacturing the probe with a suitable wear surface over the coil, or by other means specified in the inspection procedure.

3.2.1.7 Probes shall have a maximum sensing coil diameter of 0.060 inches (1.5 mm), unless otherwise specified in the inspection procedure.

3.2.1.8 The impedance of probes and adapters shall match the instrument being used.

3.2.1.~~7~~9 Precautions shall be taken to protect the part being inspected from wear or abrasion from contact with any metallic portion of the probe or test equipment.

3.2.1.8-10 Probes shall not give interfering responses from handling pressures, manipulation, or normal operating pressure variations on the sensing coil.

3.2.2 Eddy Current Instruments: Eddy current instruments are available which have a wide range of capabilities. The features required for any particular inspection shall be specified in the inspection procedure.

3.2.2.1 Display: Eddy current instruments ~~can be classified into two basic categories according to the manner in which they display shall be capable of displaying~~ eddy current information in the impedance plane format. ~~These categories are specified in 3.2.2.1.1 and 3.2.2.1.2. Either type of instrument may be acceptable for a particular inspection unless a specific type is required in the inspection procedure (reference Figures 2 and 3).~~

~~3.2.2.1.1 Instruments which use a one-dimensional meter display.~~

~~3.2.2.1.2 Instruments which use a two-dimensional impedance plane display. The~~ "impedance plane" refers to an orthogonal display of both the inductive reactance and resistance components of the complex impedance of the eddy current probe (X,Y). This type of display may be accomplished using a cathode ray tube (CRT), liquid crystal display (LCD), or other suitable method. Some instruments of this type also have the ability to produce a time-based display where one dimension of the eddy current signal is displayed as a function of time (Y,T) (reference Figures 2 and 3).

FIGURE 1 – Typical Eddy Current Probe

* This figure is unchanged from previous revision.

FIGURE 2 – Eddy Current Displays

* This figure is unchanged from previous revision

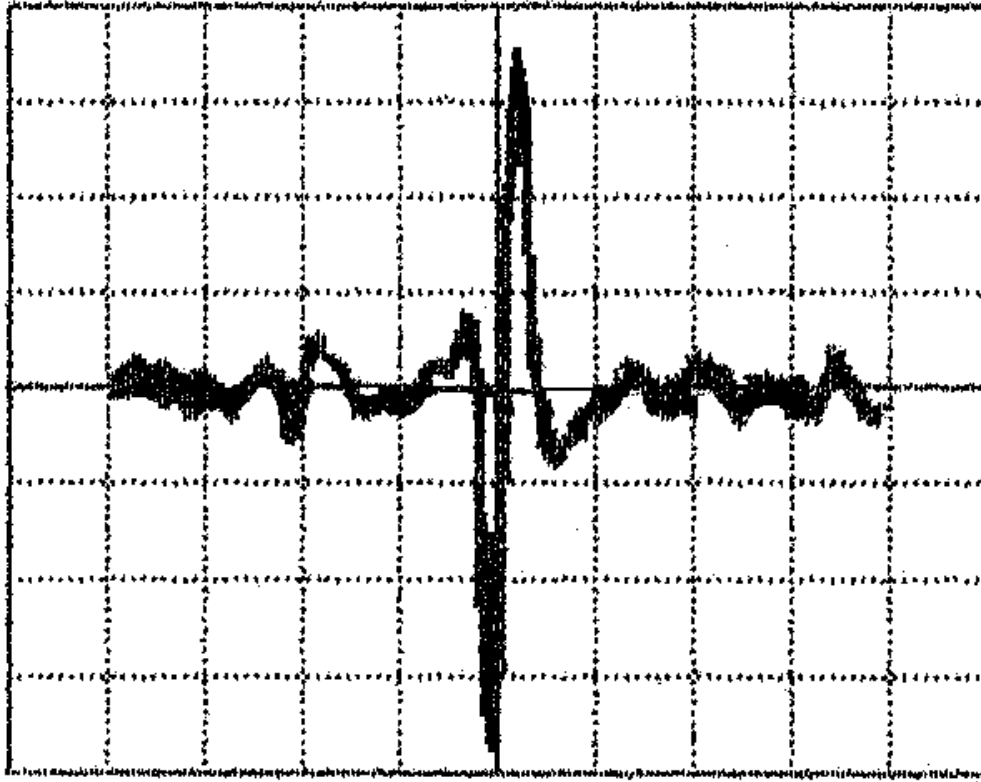

FIGURE 3 Eddy Current Time Base (Y,T) Display

- Renumber FIGURES changing old FIGURE 4 (Typical Calibration Standard) to FIGURE 6

FIGURE 6 – Typical Calibration Standard

* Modify this figure to show a “half penny” shaped EDM calibration notch with the square notch as an alternative configuration.

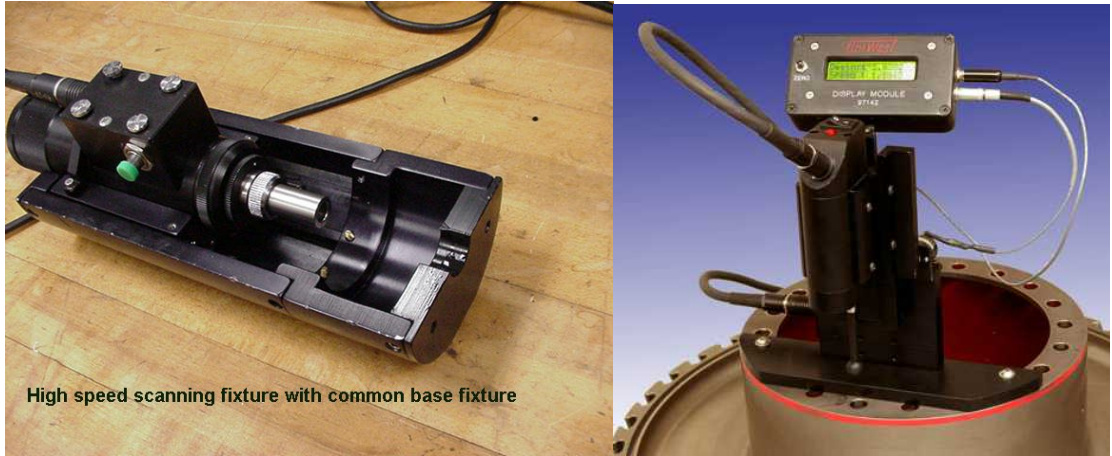

Figure 4 - Examples of Fixtured Probe Rotators with Manual Probe Translation

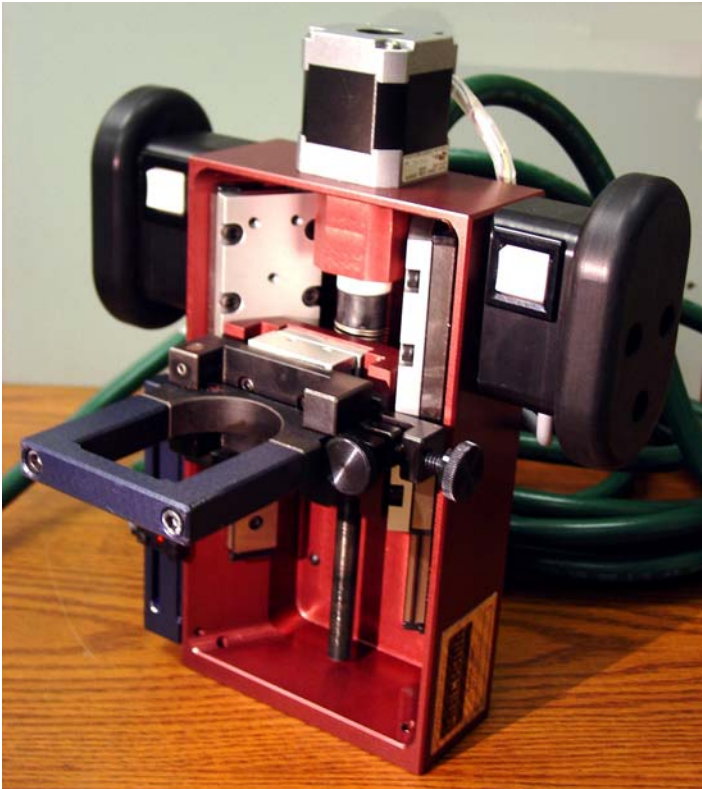

Figure 5 – Semi-Automated Scanner with Axial Probe Translation (Probe rotator and part adapter not attached)

3.2.2.2 Frequency :Instruments with variable probe excitation frequencies shall be operated at 500 KHz or higher for maximum crack detection sensitivity in materials which are typically used for aircraft engine components, unless otherwise specified in the inspection procedure. Instruments shall be capable of operating between 100 kHz and 6.0 MHz.

3.2.2.3 Filters: Electronic filters are frequently useful for reducing noise or spurious geometric signals and improving the signal to noise ratio of an inspection. Some inspections may be dependent upon the use of appropriate filters for their success. Such requirements will be specified in the appropriate inspection procedure. Three general types of filters are described as follows:

3.2.2.3.1 High Pass Filters: Eliminates or reduces the amplitude of signals which have a frequency below the frequency setting of the filter.

3.2.2.3.2 Low Pass Filters: Eliminates or reduces the amplitude of signals which have a frequency above the frequency setting of the filter.

3.2.2.3.3 Band Pass Filters: A combination of a high pass and a low pass filter which acts to eliminate or reduce the amplitude of signals which have a frequency above or below the frequency settings of the filter.

3.2.2.4 Analog Signal Output: Inspections which specify external recording or monitoring of the test signals may require the use of an instrument which has provisions for the output of analog voltages which are proportional to the eddy current signals displayed on the instrument.

3.2.2.5 Alarms: Instruments shall be equipped with an audible and/or visual alarm system.

3.2.2.6 Voltage Regulators: For other than battery-powered usage, a voltage regular shall be used on the power source if instrument internal voltage regulators are not adequate to prevent an eddy current signal amplitude variation of 10% or more.

3.2.3 Mechanical Probe Manipulation Devices:

Eddy current inspections of holes may be greatly facilitated by the use of a mechanical device to rotate the probe and translate it axially through the hole. Such devices can reduce the time required to perform an inspection and ensure that complete coverage of the hole inside diameter is obtained. Before using a mechanical manipulator the user shall verify that the rotational and axial motion speeds are appropriate for the inspection procedure. Devices can be classified into three basic categories according to the degree on mechanization. These categories are specified in 3.2.3.1, 3.2.3.2 and 3.2.3.3

3.2.3.1 Fixtured Mechanical Probe Rotator with Manual Probe Translation: This type of device provides for alignment of the probe with respect to the axis of the circular hole. This provides

a degree of reliability improvement in comparison to a handheld probe rotator. These may be centered manually from one hole to the next or adapted to fix a particular part.

3.2.3.2 Semi-Automated: Devices of this type provide alignment of a mechanical rotator and also translate the probe axially through the circular hole. In addition to reliability improvement due to probe alignment, this device can assure a constant inspection sampling-rate. Pre-designed fixtures can adapt this device to engine hardware to provide rapid hole-to-hole placement and centering (ref. Figure X).

3.2.3.3 Automated: These devices can be programmed to provide automatic probe motion, translation, hole-to-hole indexing, instrument set-up, evaluation, etc. dependant upon the degree of automation, all of which provides increasing capability for improving inspection reliability. Typically, these are stationary devices requiring parts to be brought to them for inspection.

3.2.4 Data Recording Devices: Inspections ~~which that~~ require the recording or documentation of some or all of the test signals produced during the inspection may utilize recording devices. Such devices may be incorporated into the eddy current instrument or in a separate instrument. Such devices may consist of paper chart recorders, magnetic tape recorders, digital data acquisition instruments, or similar device. The recording device used shall be appropriate for the type and quantity of data to be recorded. Specific details regarding recording device requirements shall be contained in the inspection procedure.

3.2.5 Calibration Standards:

3.2.5.1 Calibration standards are required to establish equipment sensitivity prior to performing an inspection. Unless otherwise specified by the purchaser, standards shall be fabricated from the same material as the component to be inspected.

3.2.5.2 Notches or similar artificial defects shall be created in the standards to provide a uniform, repeatable source of an eddy current indication during equipment calibration. The size of artificial defect needed for an inspection shall depend on the requirements of the particular inspection and will be specified in the inspection procedure. A 0.030-inch long by 0.015-inch deep, half-penny profile EDM notch is recommended for calibration. EDM notch width is typically 0.002-0.003 inches.

3.2.5.3 Calibration standards shall be identified with the material, part number, hole size, unique serial number, and notch size (reference Figure 4).

3.2.5.4 Calibration standard dimensions, including hole sizes and notch sizes, shall be measured and documented. Tolerances shall be specified in the inspection procedure. Certification and traceability of these measurements may be required by the purchaser.

3.2.5.5 The electrical conductivity of calibration standards shall be similar to that of the part to be inspected. The tolerance in conductivity variation between calibration standards and test parts shall be specified in the inspection procedure. If specifically approved by the purchaser, calibration standards with electrical conductivities different from that of the part to be inspected may be used when appropriate correction factors are **also** provided. The tolerance in conductivity variation between calibration standards and test parts should be no greater than 2 and no less than 2/3 times the conductivity of the material to be inspected. ~~The tolerance in conductivity variation between calibration standards and test parts shall be specified in the inspection procedure. It may be acceptable to use calibration standards with electrical conductivities different from that of the part to be inspected if this is specifically approved by the purchaser and appropriate correction factors are provided.~~

3.2.5.6 Calibration standard finish shall be 63 RMS or better.

3.3 Personnel Qualification:

Personnel performing eddy current hole inspections shall be qualified and certified in accordance with MIL-STD-NAS-410 or SNT-TC-1A. Other procedures (ATA 105, etc) may be used with prior approval of the purchaser.

3.4 Inspection Procedure Requirements:

Eddy current hole inspections shall be performed in accordance with a detailed inspection procedure for the component to be tested. Each procedure shall be ~~prepared and~~ verified and approved by a certified eddy current Level III employed the purchaser or his designee. A copy of each applicable procedure shall be readily available to all inspection personnel for reference and use while performing the inspection. Procedures shall comply with the general requirements of this specification and shall provide all of the specific information required to set up the equipment and perform the test. Each procedure shall include not less than the following information:

3.4.1 Name and part number to which the procedure applies (include serial number if applicable)

3.4.2 A description and sketch identifying the holes to be inspected, if this is not readily apparent.

3.4.3 Part cleaning and preparation instructions

3.4.4 A description and/or sketch of the manner in which the holes are numbered or referenced from the geometry of the part for identification purposes.

3.4.5 Inspector training and qualification requirements

3.4.6 Inspection equipment, probe and fixture requirements, including manufacturer and model number where appropriate

3.4.7 Calibration standard to be used

3.4.8 Inspection equipment setup and operation parameters

3.4.9 Pretest calibration procedure

3.4.10 Part inspection procedure

3.4.11 Post-test calibration procedure and calibration check intervals

3.4.12 Instructions regarding the evaluation of suspect eddy current indications

3.4.13 Acceptance criteria

3.4.14 Instructions regarding inspection records which shall be completed and maintained

3.4.15 Part disposition

3.4.16 It is recommended that there is a method of marking parts that have been inspected and accepted.

3.5 Part Preparation for Inspection:

3.5.1 Verify that the inspection procedure is applicable to the part to be inspected.

3.5.2 Identify the location, number, and size of holes to be inspected.

3.5.3 Visually inspect the holes under a white light [recommended 100 ft-c (10762x)] for evidence of burrs, out of round condition, dirt, rubbing, fretting, foreign material, or other contamination which would interfere with the inspection process. Borescopes or other optical aids may be used to enhance the visual inspection.

3.5.4 Use approved cleaning materials to clean the holes or contact cognizant engineering activity for corrective action if the holes cannot be cleaned.

3.5.5 Number the holes for identification.

~~3.6 Equipment Calibration – Manual Probe Manipulation:~~

~~3.6.1 Connect the probe and instrumentation according to the manufacturer's directions.~~

~~3.6.2 Adjust the initial equipment settings as specified by the inspection procedure or quality assurance plan.~~

~~3.6.3 If the probe diameter is variable, adjust the probe to fit the holes to be inspected. The probe shall fit snugly but not so tight as to cause excessive wear of the probe. On inserting or withdrawing the probe, there should be a light positive drag.~~

~~3.6.4 Place the probe in the probe collar and on the surface of the calibration standard, away from the calibration notch.~~

~~3.6.5 Null (or balance) the eddy current instrument.~~

~~3.6.6 Rotate the coil across the calibration notch and identify the coil position which produces the largest notch signal amplitude.~~

~~3.6.7 Rotate the coil across the calibration notch at the location of the maximum response and adjust the instrument phase (or rotation) control to orient the defect signal as specified in the inspection procedure.~~

~~3.6.8 Adjust the gain (or sensitivity) controls to produce the notch signal amplitude specified in the inspection procedure.~~

~~3.6.9 Repeat this process until an accurate calibration is achieved and null the instrument after any changes in gain or phase/rotation.~~

~~3.6.10 Perform a scan of the notch at the index rate specified in the procedure to verify the accuracy of the calibration.~~

***Renumber to end**

3.7 Equipment Calibration - Mechanical Probe Manipulation:

3.7.1 Connect the probe and instrumentation according to the manufacturer's directions.

3.7.2 Adjust the initial equipment settings as specified by the inspection procedure or quality assurance plan.

3.7.3 If the probe diameter is variable, adjust the probe to fit the holes to be inspected. The probe shall fit snugly but not so tight as to cause excessive wear of the probe. On inserting or withdrawing the probe there should be a light positive drag.

3.7.4 Align the probe and manipulator with the calibration standard hole to be used for calibration.

3.7.5 Drive the probe into the hole and stop it when the coil is positioned away from the calibration notch.

3.7.6 Null (or balance) the eddy current instrument.

3.7.7 While the probe is rotating at the desired speed, translate the probe slowly over the notch. Stop the probe translation when the point of maximum notch response is attained. Continue to rotate the probe.

3.7.8 Adjust the instrument phase/rotation control to orient the notch signal as specified in the inspection procedure.

3.7.9 Adjust the gain (or sensitivity) control to produce the notch signal amplitude specified in the inspection procedure. Null after any adjustments to gain or phase rotation.

3.7.10 Repeat this process until an accurate calibration is achieved.

3.7.11 Perform a scan of the notch at the index rate specified in the inspection procedure to verify the accuracy of the calibration. In the case of helical "indexing" an equivalent index value may be determined the following:

Equivalent Index for Helical Scans = Axial Velocity (in/sec.) x 60 ÷ Probe Rotator RPM

3.8 Part Inspection - General Requirements:

3.8.1 The inspection parameters listed below shall not be adjusted after calibration as they may reduce the inspection system sensitivity and affect the inspection results.

3.8.1.1 Test frequency

3.8.1.2 Gain (or sensitivity)

3.8.1.3 Phase (or rotation)

3.8.1.4 Probe rotational speed

3.8.1.5 Type and frequency of filtering used

3.8.1.6 Probe drive signal voltage or current

3.8.1.7 Test material

3.8.2 If low-friction tape is used to prevent or reduce probe wear, it will be necessary for the inspector to check the tape condition periodically. If the tape has worn significantly, it shall be replaced before performing additional inspections.

3.8.3 Any eddy current signals ~~which~~ that meet or exceed the rejection criteria specified in the inspection procedure shall be noted for later evaluation.

3.8.4 The eddy current probe shall be properly aligned during inspection of all holes.

3.8.5 Record all inspection results and instrument settings as specified in 4.1.

3.9 Post-Test Calibration Check:

3.9.1 The calibration of the inspection equipment shall be checked against the calibration standard at least every 4 hours or when any other critical component of the inspection system changes. It shall also be checked upon completion of an inspection.

3.9.2 If the eddy current signal produced from the calibration standard notch is within the limits of the original calibration level as specified by the inspection procedure, the test shall be considered acceptable.

3.9.3 If the notch signal has decreased by more than the specified limits from the original calibration level, the test shall be considered unacceptable and all parts inspected since the last acceptable calibration shall be reinspected.

3.9.4 If the notch signal has increased by more than the specified limits from the original calibration level, the test shall be considered acceptable. All parts rejected since the last acceptable calibration check shall be reinspected and evaluated, if necessary per 3.10.

3.10 Indication Evaluation:

3.10.1 Evaluate any area where indications were obtained which met or exceeded the rejection criteria specified in the inspection procedure or other referenced document.

3.10.2 Reclean the area where the indication was obtained.

3.10.3 Check the inspection system calibration and reinspect the suspect area.

3.10.4 If the indication has been reduced to below the inspection procedure rejection criteria, the indication shall not be cause for rejection of the part.

3.10.5 If the indication remains above the rejection limit, but has reduced from its previous level, it may be caused by a surface condition. Additional cleaning may reduce the indication further.

3.10.6 If the indication remains above the rejection threshold, the part shall be rejected.

4. QUALITY ASSURANCE PROVISIONS:

4.1 Records:

Inspection records shall include the following information regarding the inspection:

4.1.1 Date of inspection

4.1.2 Location where inspection is performed

4.1.3 Inspector's name and acceptance/rejection stamp

4.1.4 Part name

4.1.5 Part number

4.1.6 Part serial number

4.1.7 Inspection results

4.2 Facilities/Equipment:

Shall be subject to survey and approval by the purchaser and shall include, but not limited to, test equipment, calibration standards, probes, fixtures, reference documentation, personnel certification, and procedures.

4.3 Calibration Standards:

Shall be certified when required by the purchaser. The purchaser shall maintain master calibration standards and shall have the responsibility of establishing equivalent responses if allowed by the inspection procedure/quality assurance plan.

4.4 Inspection Procedures:

Shall be maintained by the purchaser.

4.5 Quality Assurance Plans:

Shall be maintained by the supplier.

4.6 Calibration System:

Shall be maintained in accordance with ~~MIL-STD-45662~~ ISO 10012 if required by the purchaser or other method acceptable to the purchaser's quality assurance.