

MXRF Molecular Recognition

MXRF-Based Molecular Recognition Technology

Benjamin Warner, George Havrilla, Thomasin Miller, Cyndi Wells
Chemistry Division, and
Non-Proliferation and International Safeguards Division
Los Alamos National Laboratory



MXRF Molecular Recognition

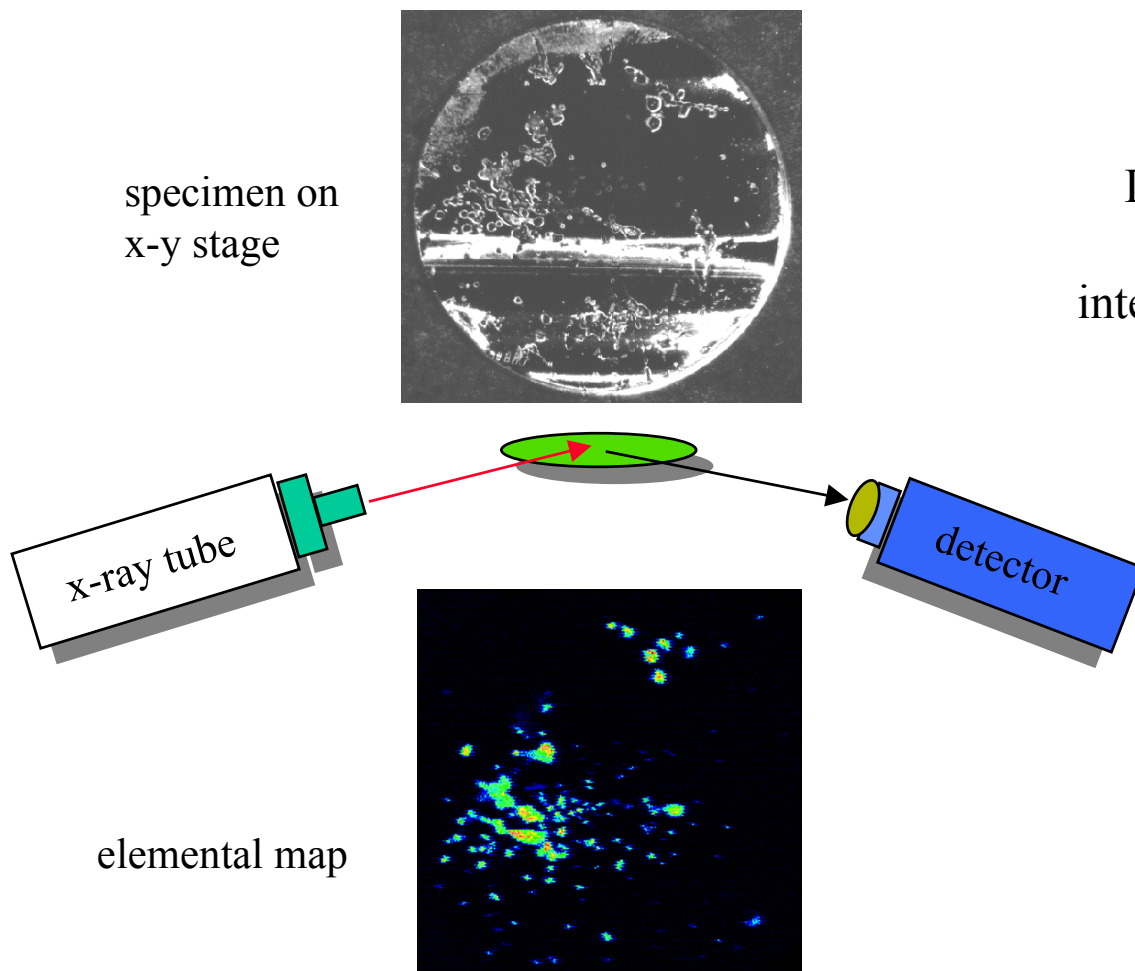

X-ray fluorescence:

Detect and quantify elements by measuring wavelengths and intensities of characteristic emissions

Advantages:

- Non-destructive
- No sample preparation
- Elemental analysis
- “Tags” not necessary
- Nanogram detection
- Screens 15 compounds/sec

MXRF Molecular Recognition

Technology

Previous reports stated that a synchrotron was necessary for

- (a) Sufficient resolution
- (b) Sufficient beam intensity, especially to penetrate capillary

Our results include

- (a) Bench-top microfocus instruments have sufficient resolution, which is less than the nominal spot size
- (b) Bench-top microfocus instruments have sufficient intensity to penetrate capillaries
- (c) Detection limits are on the sub-nanogram level

MXRF Molecular Recognition

Technology

We attempted the following reaction (Berkessel and Herrault, ACIEE, 1999, 38, 102 – 105):

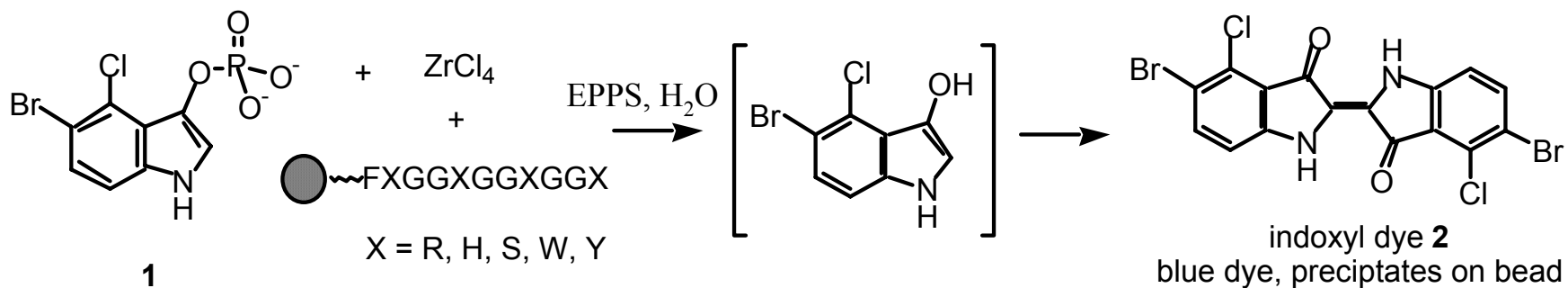

LANL

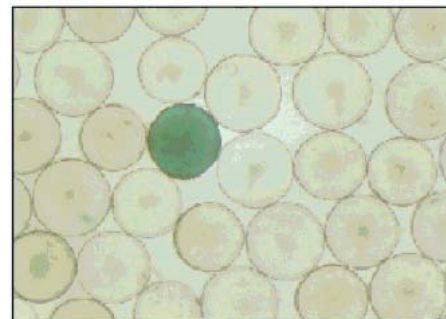

Berkessel

MXRF Molecular Recognition

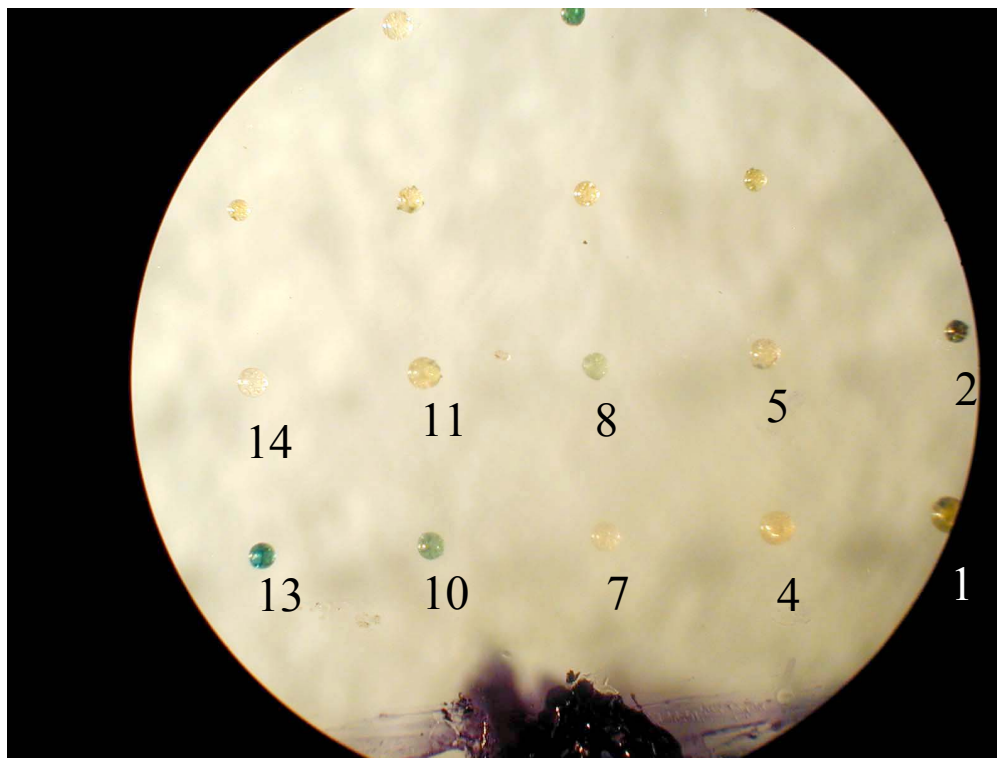

Bead 13: $\text{H}_2\text{N-Ser-Gly-Gly-His-Gly-Gly-Arg-Gly-Gly-His-Phe-CO}_2\text{H}$
Bead 10: $\text{H}_2\text{N-Ser-Gly-Gly-His-Gly-Gly-Arg-Gly-Gly-Arg-Phe-CO}_2\text{H}$

MXRF Molecular Recognition

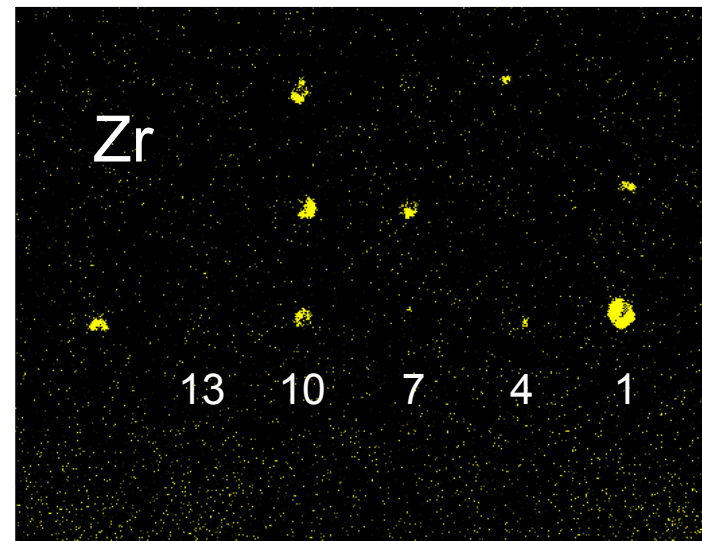
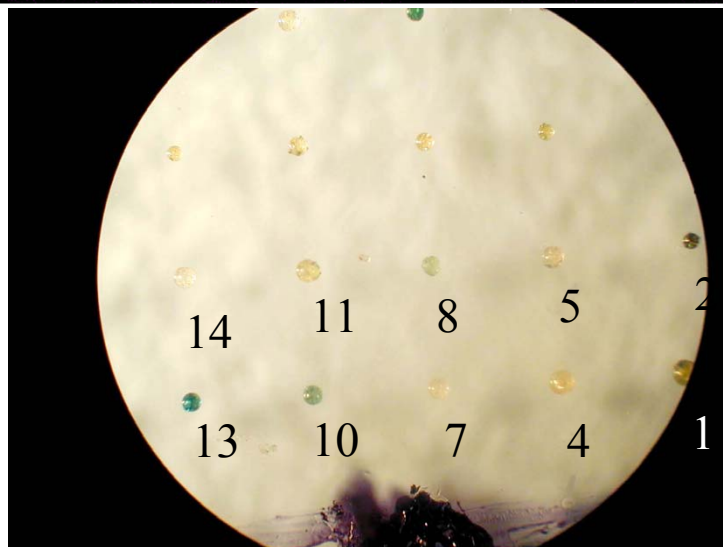
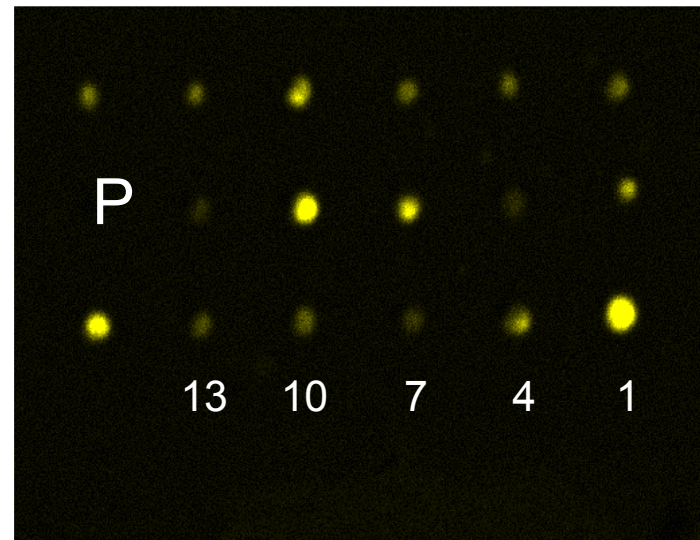
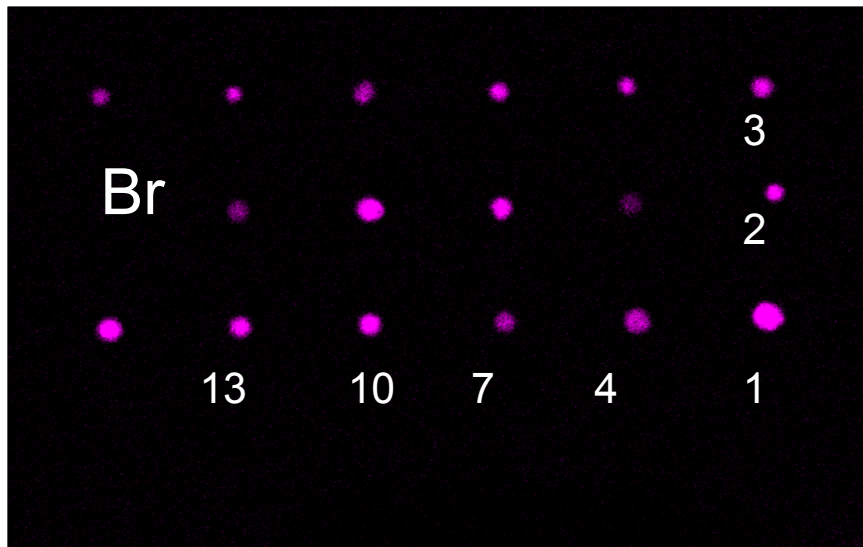

MXRF Molecular Recognition

Visual Method:

- 1) Little information on binding :
 - peptide only
 - peptide + substrate
 - peptide + substrate + metal

All three possibilities result in clear beads.

- 2) Subjective interpretation:
i.e. dark blue vs. light blue

- 3) Activity of the catalyst:
only know product

MXRF Method:

- 1) Full information on binding :
 - peptide only
 - peptide + substrate
 - peptide + substrate + metalCan differentiate and quantify.

- 2) Quantitative interpretation:
i.e. quantify amounts of each element

- 3) Activity of the catalyst:
TON: product to catalyst ratio

MXRF Molecular Recognition

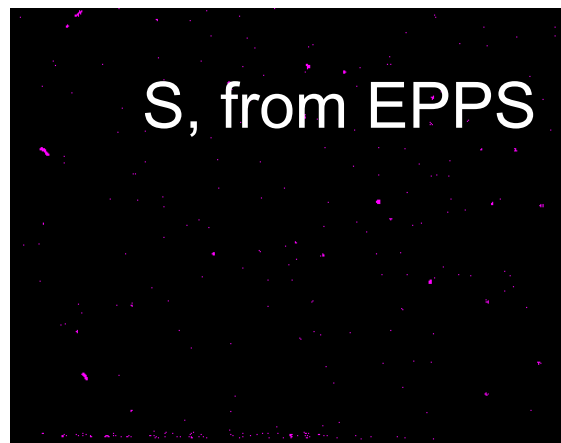
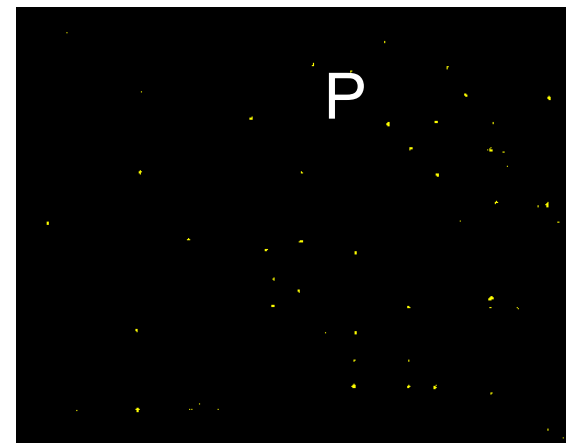
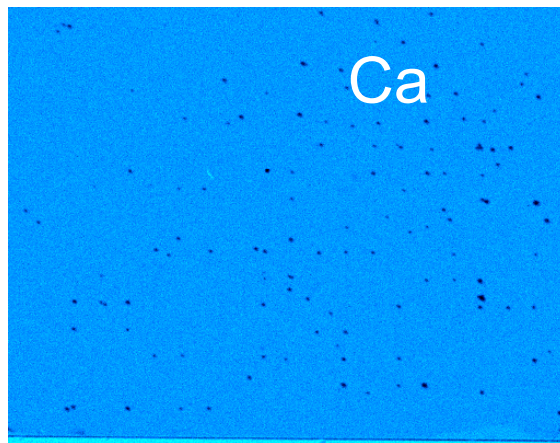

EPPS

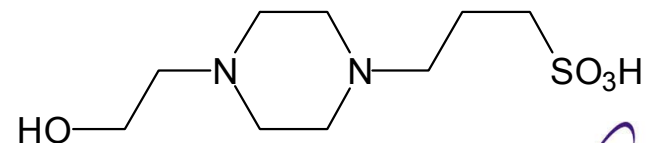

MXRF Molecular Recognition

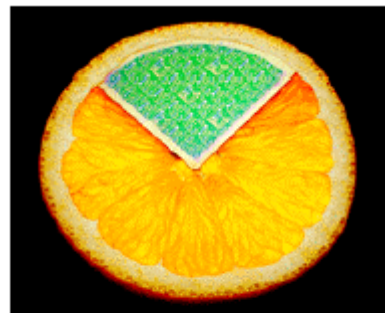
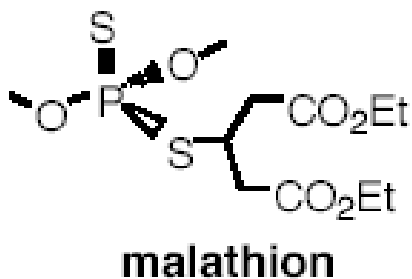
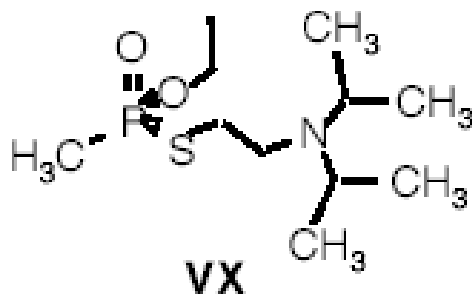

Surface acoustic wave-based MEMs
(JCAD, MiniCAD are SAW-based)

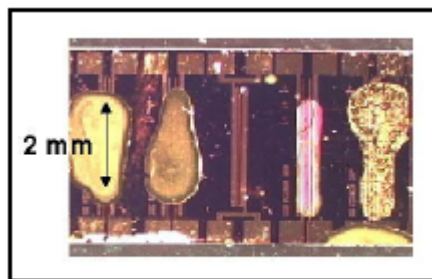

Chemiresistors

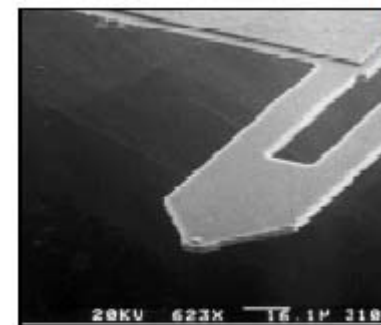

Microcantilever-based MEMs

MXRF Molecular Recognition

- “Chemically-selective” elements are often “future work”.
 - In general, the current coatings are not effective.
 - Coatings form the failure point for accurate sensing.

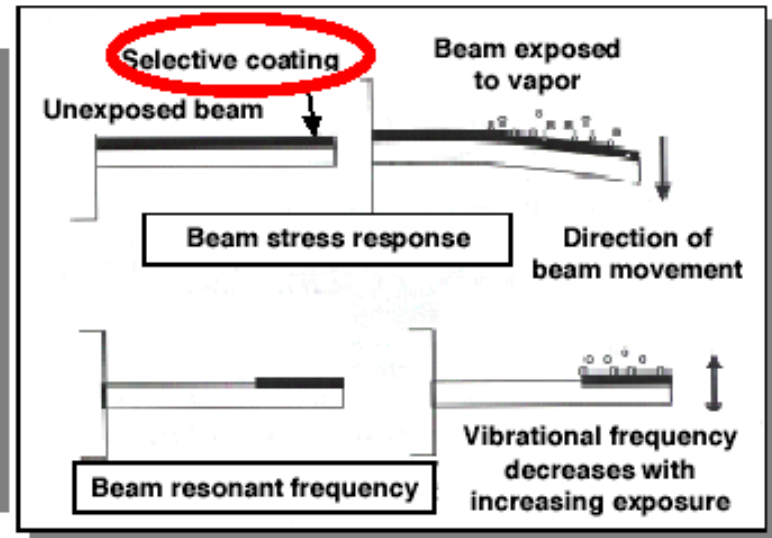
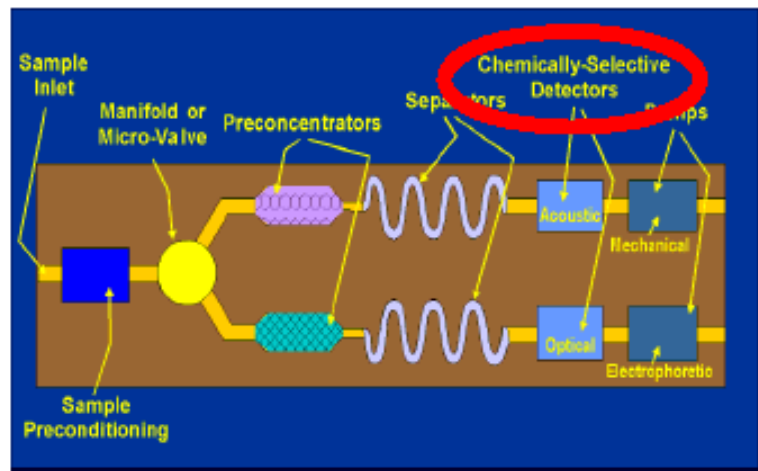

MXRF Molecular Recognition

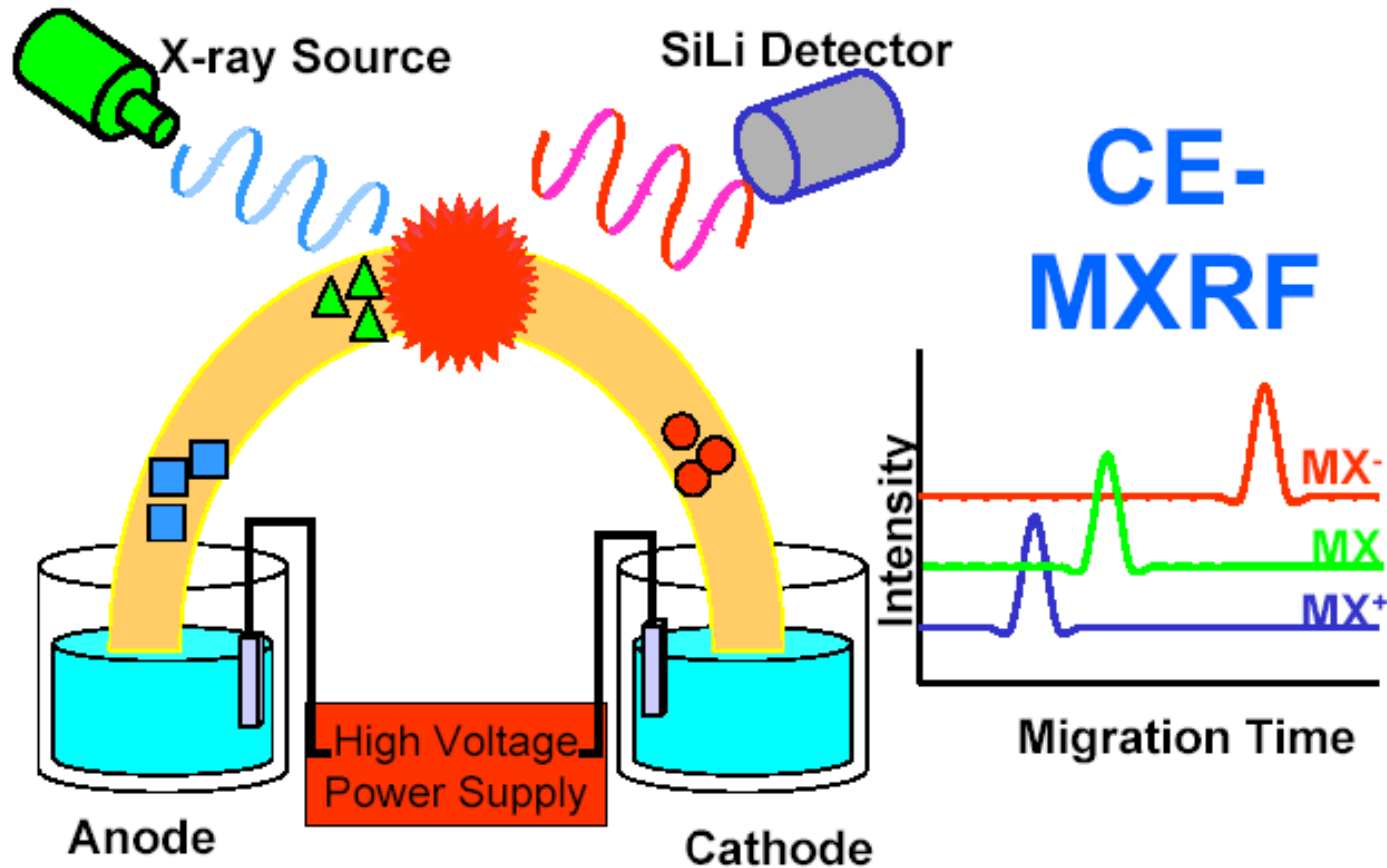

Simultaneous, on-line, multi-elemental detection, $Z \geq 11$

MXRF Molecular Recognition

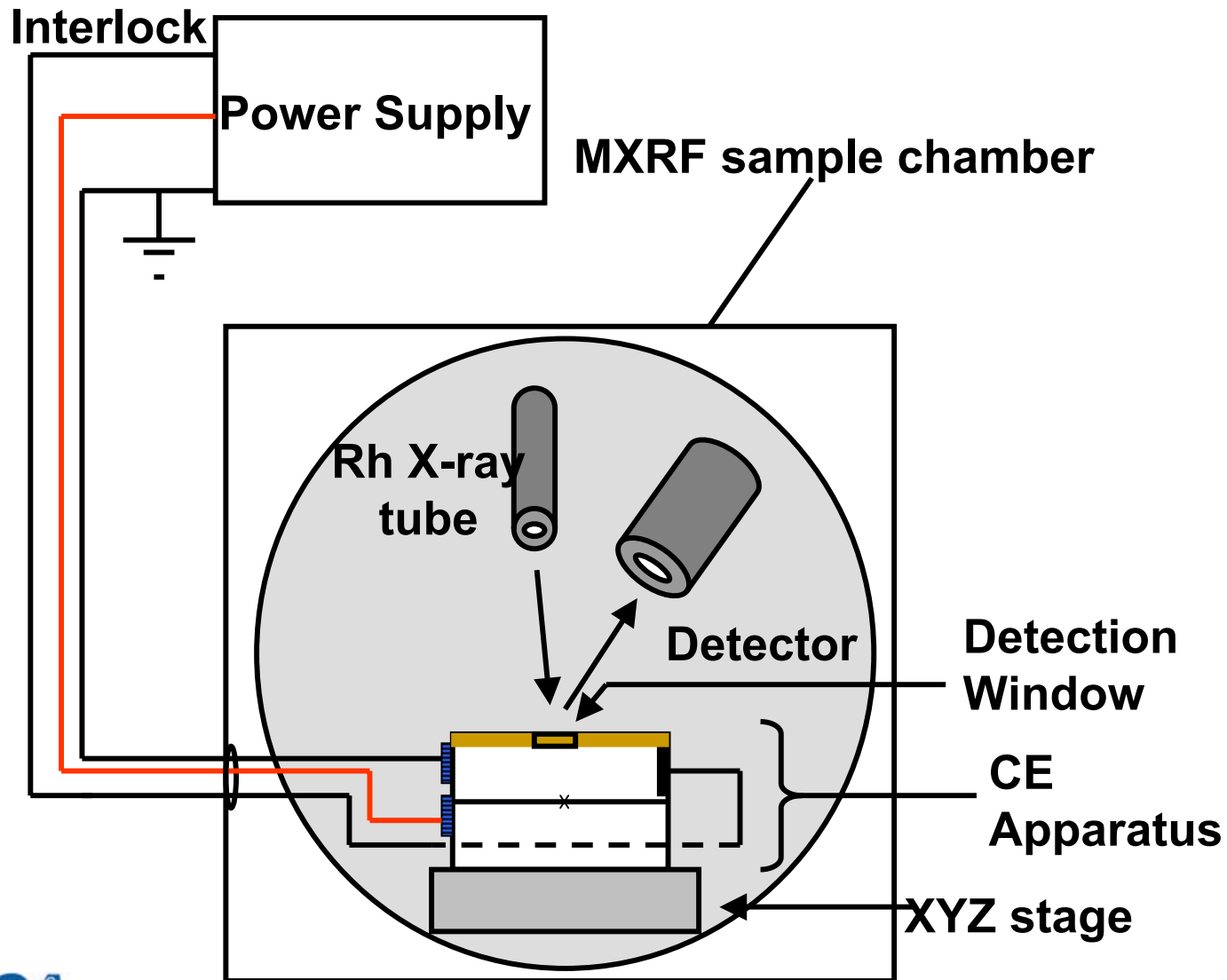

MXRF Molecular Recognition

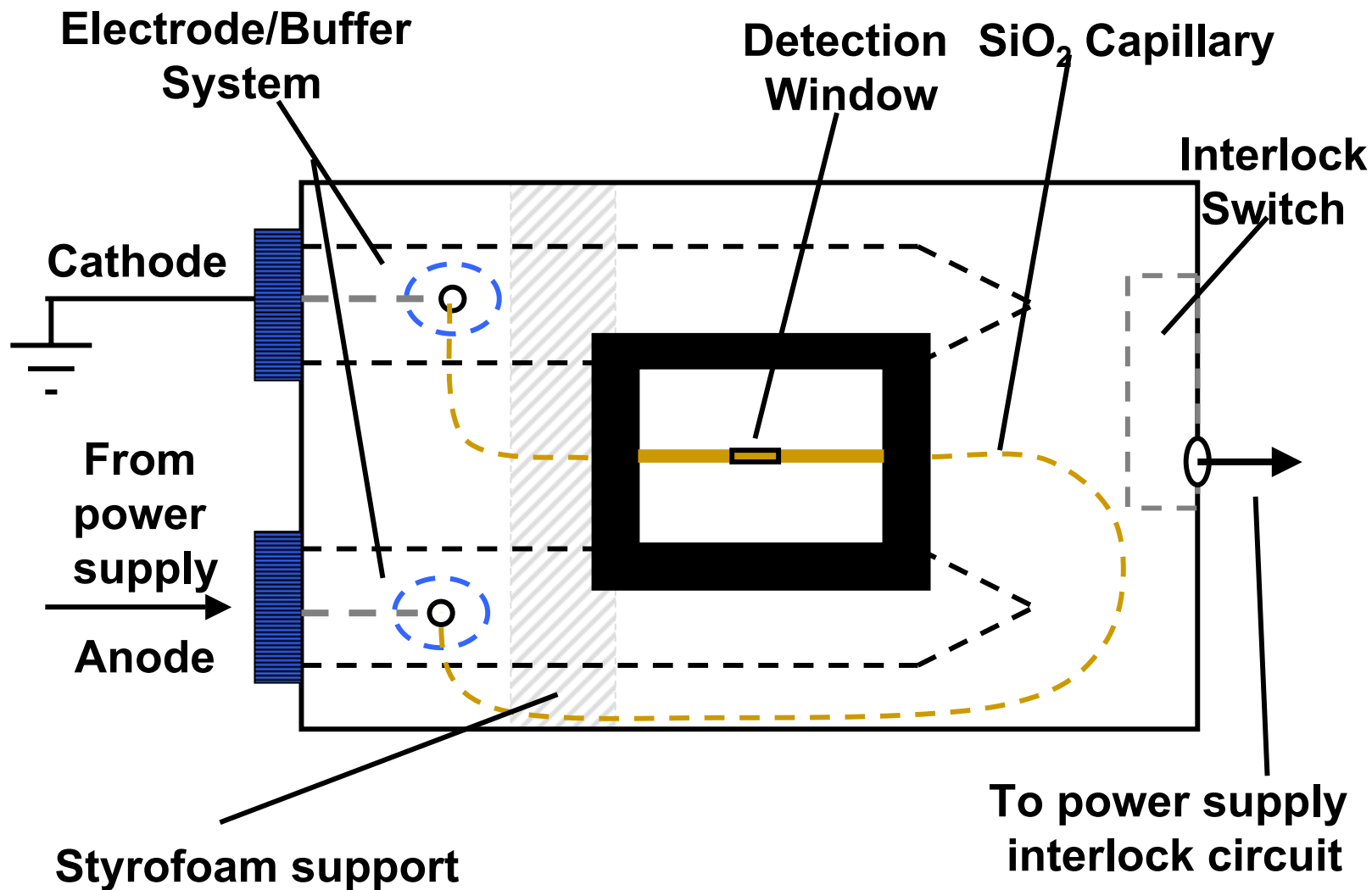

MXRF Molecular Recognition

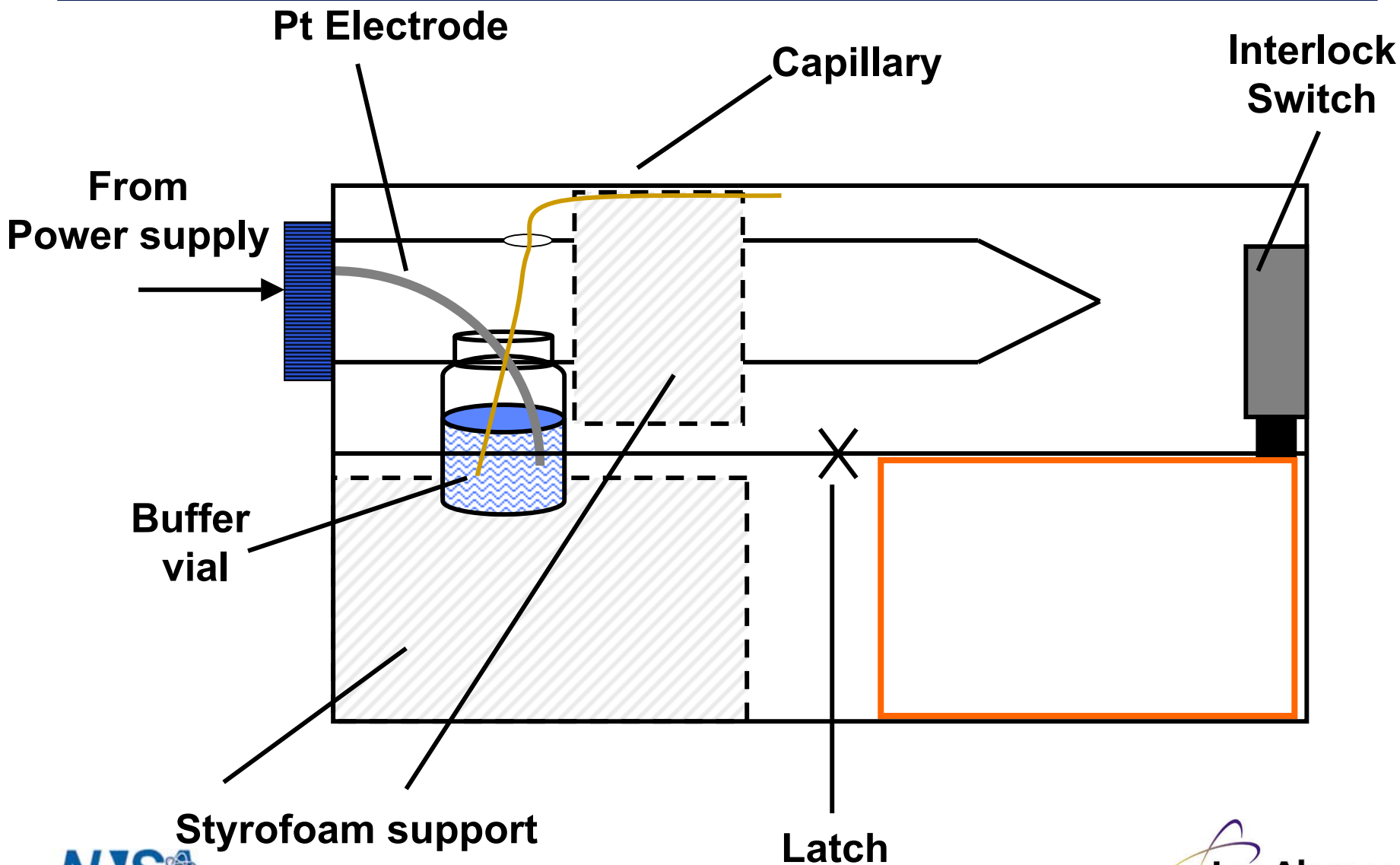

MXRF Molecular Recognition

Selection of Capillary

SiO ₂ Tubing	Dimensions			Detection Limit (mMolar)*			
	O.D. (μm)	I.D. (μm)	Wall Thickness (μm)	Cu	Zn	Fe	Co
TSP167100	164	97	33	1.32	2.35	1.58	1.90
TSP250350	362	256	53	0.72	1.10	0.16	0.53
TSP530660	666	534	66	0.13	0.32	0.18	0.42
TSP075375	363	75	144	31.23	7.46	16.76	21.19

* Based on sample volume assuming a 50 μm MXRF spot size

Higher energy X-rays allow detection of species through thin-walled fused silica capillary

MXRF Molecular Recognition

Aqueous Metal Separation

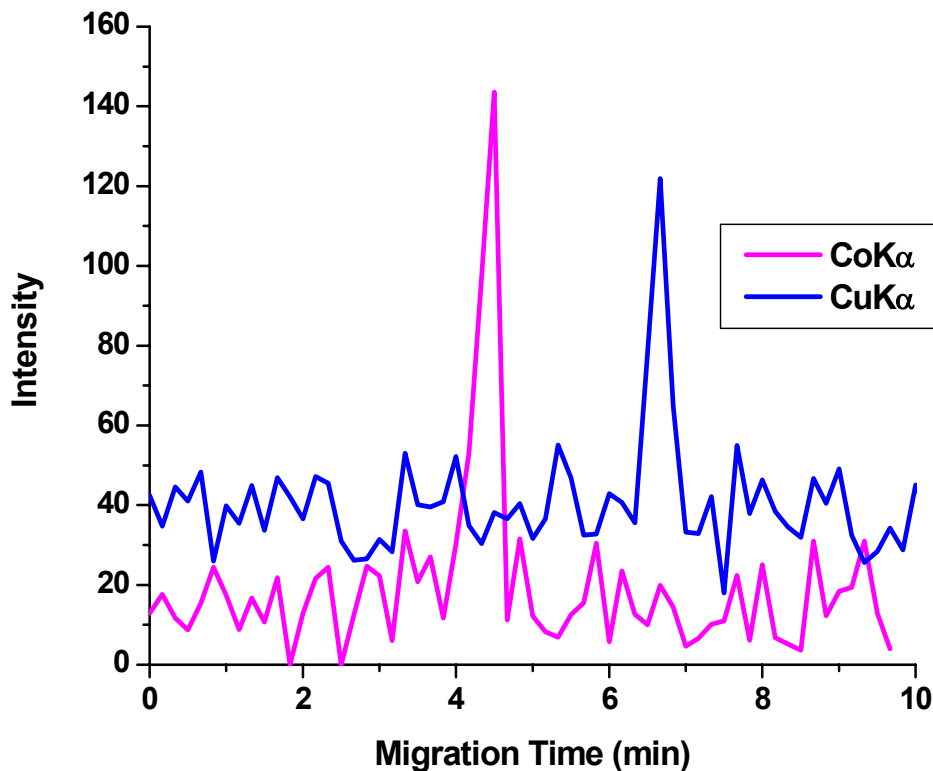

- 1.6 mMolar Cu²⁺ and Co²⁺ in de-ionized H₂O
- 70 cm capillary (100 μ m id, 170 μ m od)
- 50 mM NH₄OAc run buffer, pH 4.5
- 4 s pressure injection at 380 mbar
- 10 KV running potential

MXRF Molecular Recognition

Aqueous Separation of Co^{2+} and Cyanocobalamin (Vitamin B-12)

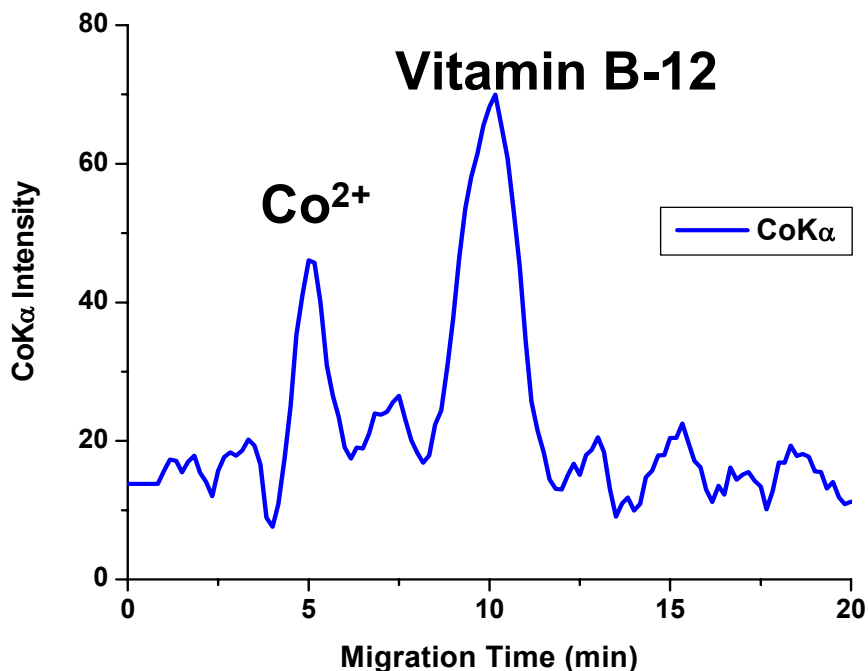

- 3.4 mMolar Co^{2+} and 10.2 mMolar Cyanocobalamin in de-ionized H_2O
- 70 cm capillary (100 μm id, 170 μm od)
- 75 mM Trizma run buffer, pH 8.0
- 4 s pressure injection at 380 mbar
- 10 KV running potential

MXRF Molecular Recognition

Separation of Ferritin and Cyanocobalamin (Vitamin B-12)

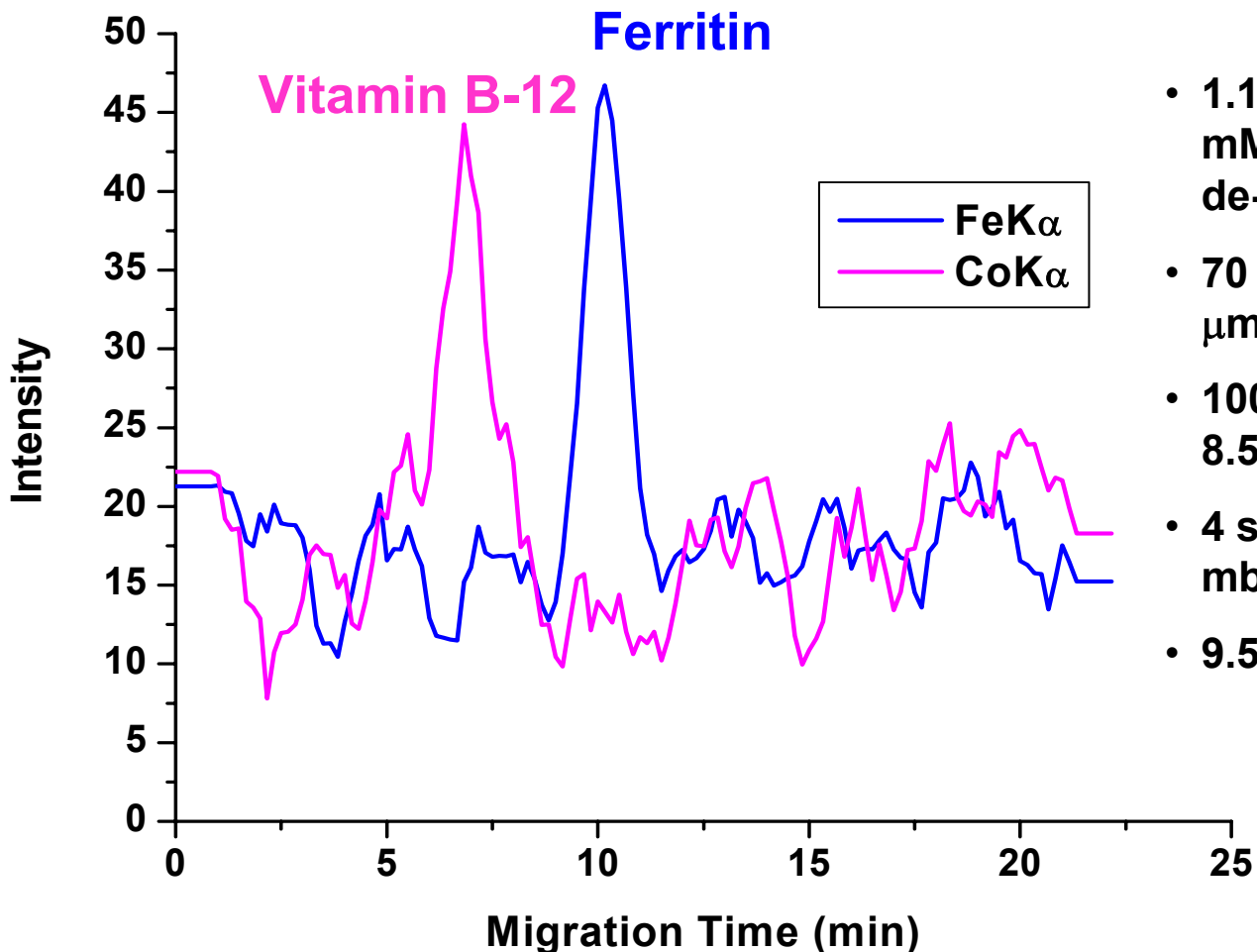

- 1.16 mg/mL Ferritin* and 10.2 mMolar Cyanocobalamin in de-ionized H₂O
- 70 cm capillary (100 μ m id, 170 μ m od)
- 100 mM Trizma run buffer, pH 8.5
- 4 s pressure injection at 253 mbar
- 9.5 KV running potential

MXRF Molecular Recognition

Common CE Elemental Detection Methods

Method	Typical Detection Limits	Advantages	Disadvantages
PIXE (e.g. C. Vogt et al. J. Chromatogr. A 727 (1996) 301-310.)	10^{-7} - 10^{-5} M	<ul style="list-style-type: none">• Simultaneous multi-elemental analysis, $Z > 13$	<ul style="list-style-type: none">• Limited Access• Radiolysis inside capillary requires decoupling of separation and detection• Requires an etched 10 μm SiO₂ window
Synchrotron-XRF (e.g. S.E. Mann et al. Anal. Chem. 2000, 72, 1754-1758.)	$\sim 10^{-4}$ M	<ul style="list-style-type: none">• Simultaneous, on-line, multi-elemental detection, $30 > Z > 17$• Nondestructive	<ul style="list-style-type: none">• Limited Access• Requires a polyethylene window
ICPMS (e.g. V. Majidi et al. Analyst, May 1998, Vol 123 (803-808).)	10^{-11} - 10^{-9} M	<ul style="list-style-type: none">• Simultaneous, on-line, multi-elemental detection• Isotope specific detection	<ul style="list-style-type: none">• Destructive,• Complicated interface• Affected by buffer/ matrix effects• Strong Fe interferences

MXRF Molecular Recognition

Deposition Reproducibility with Nanoliter Injector

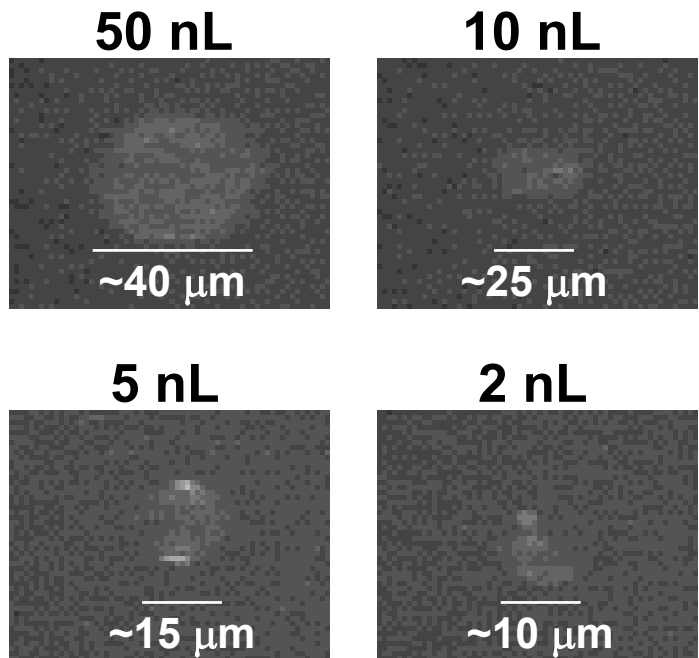

All spots were deposited with a Nanoliter Injector A203 (WPI Inc.)

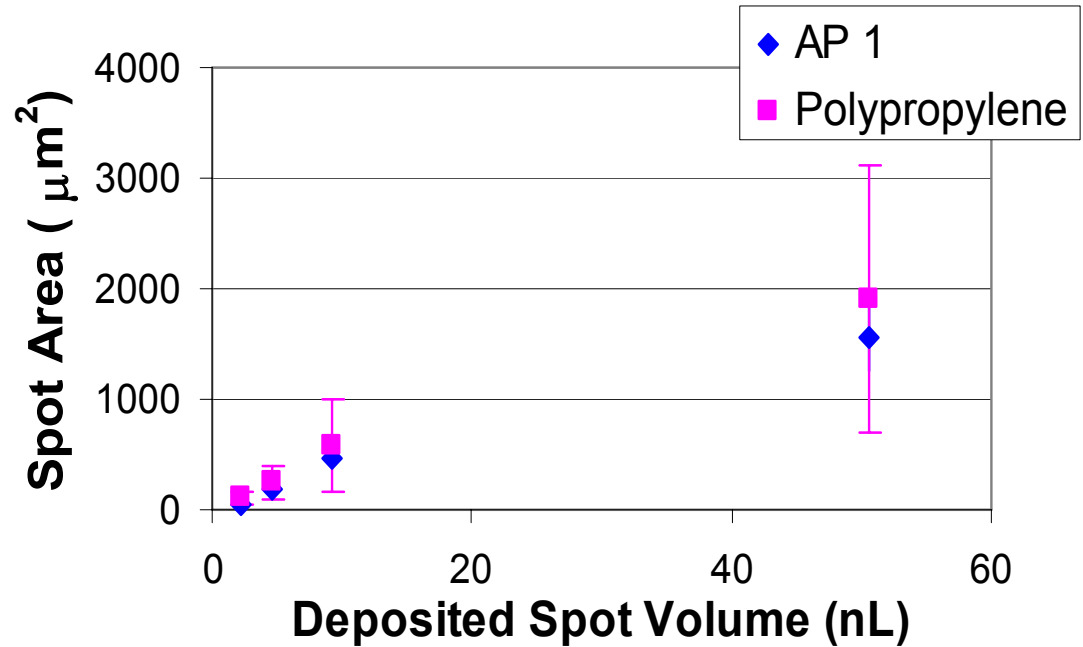

Deposition onto AP1 film produced the most reproducible spots.

MXRF Molecular Recognition

Effect of Multiple Elements on the Intensity of a Single Element in a Dried Spot

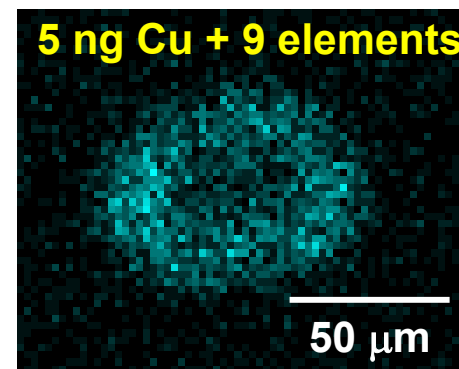
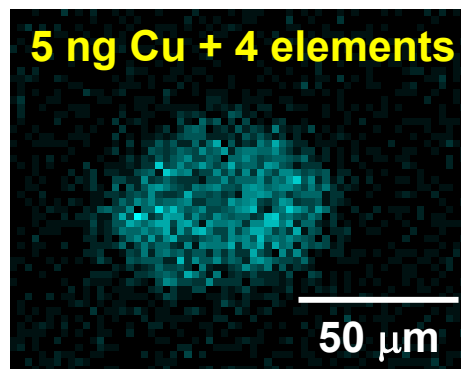
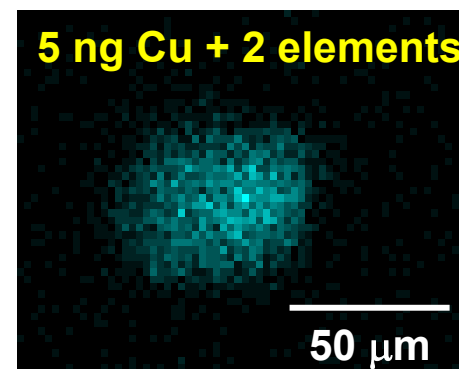
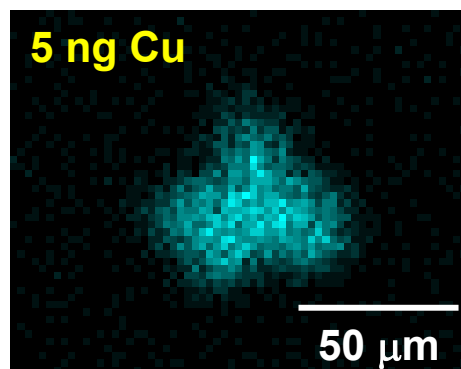
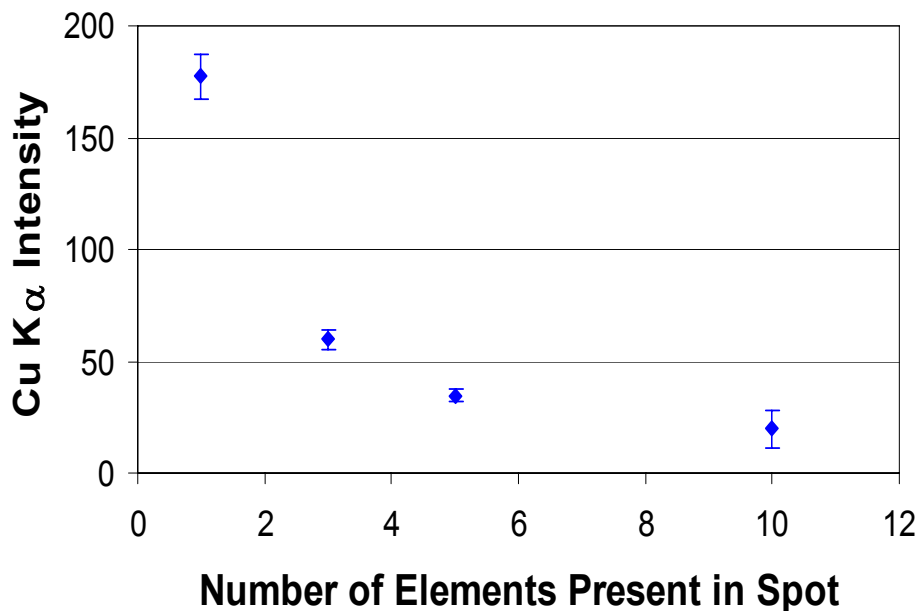

All spots were dried on AP 1 Film using the UltraMicro Pump II Microliter injector (WPI Inc.).

MXRF Molecular Recognition

Effect of Multiple Elements on the Intensity of a Single Element in a Dried Spot

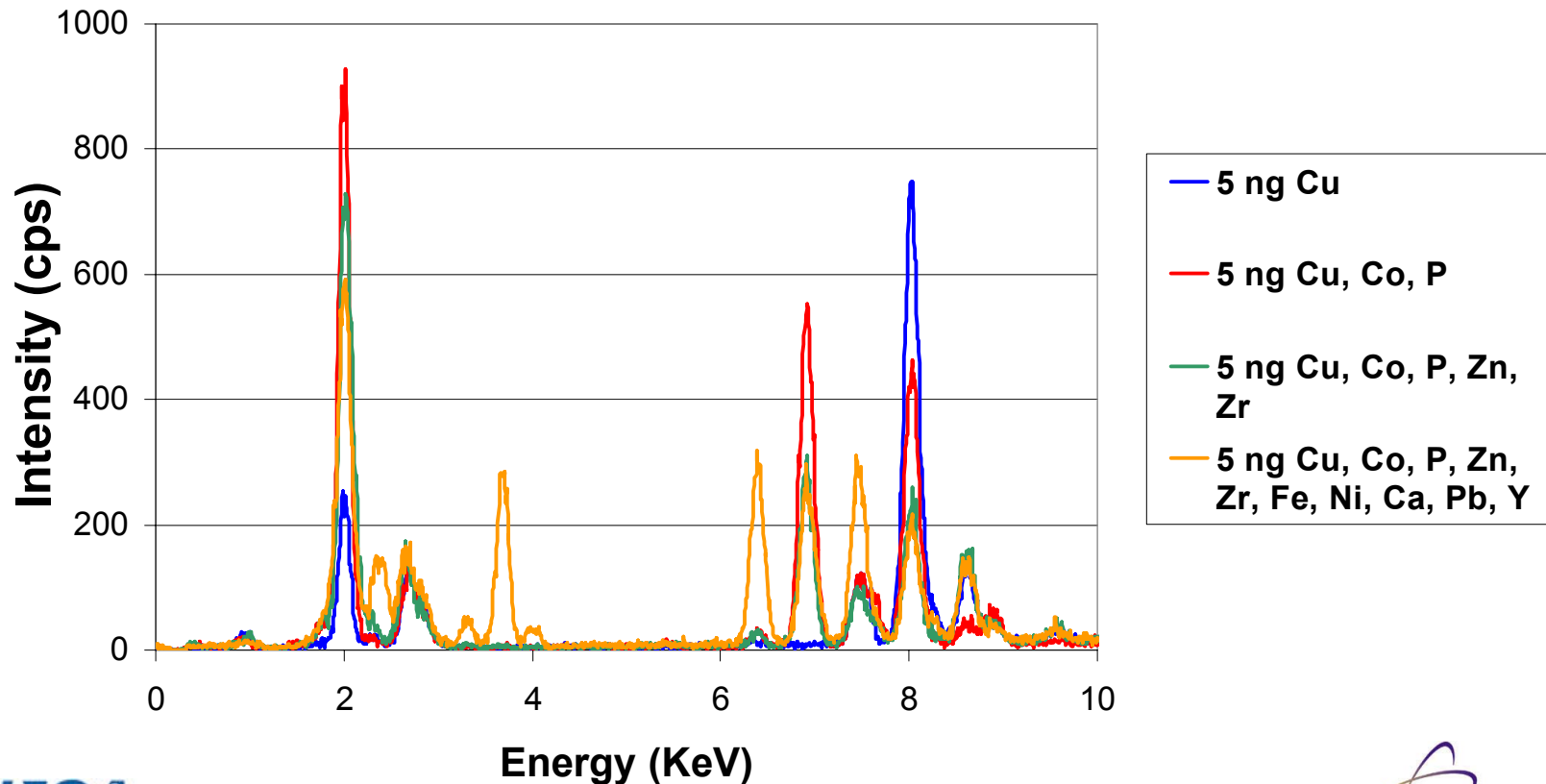

MXRF Molecular Recognition

Constant Volume Spots, Variable Mass Deposited

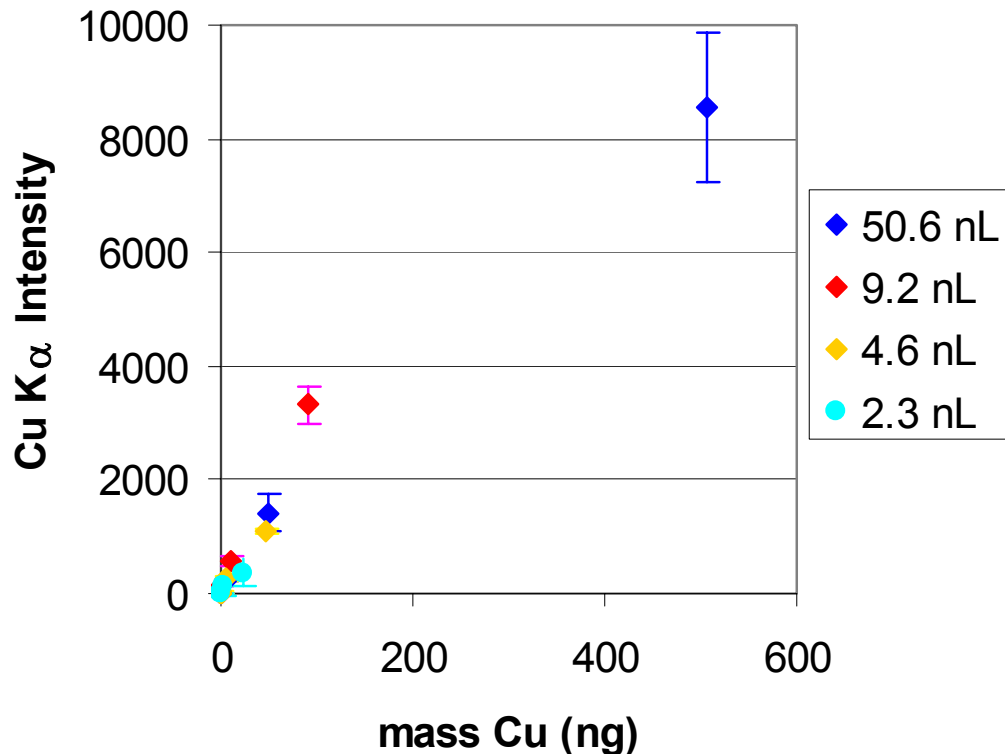

➤ **Cu intensity increases with mass deposited**

➤ **Precision decreases with increasing mass deposited**

MXRF Molecular Recognition

Detection Limit of Cu for Given Dried Spot Volumes

Volume of Spot Deposited (nL)	Cu Detection Limit (ng)	
	AP1	Polypropylene
2	0.1	0.4
5	0.2	0.6
10	0.4	0.8
50	1.8	2.6

- Lower detection limits achieved with AP1 film
- Detection limits decrease with smaller spot volume

All spots were deposited using a Nanoliter Injector A203 (WPI Inc.).

MXRF Molecular Recognition

Constant Mass Spots, Variable Volume Deposited

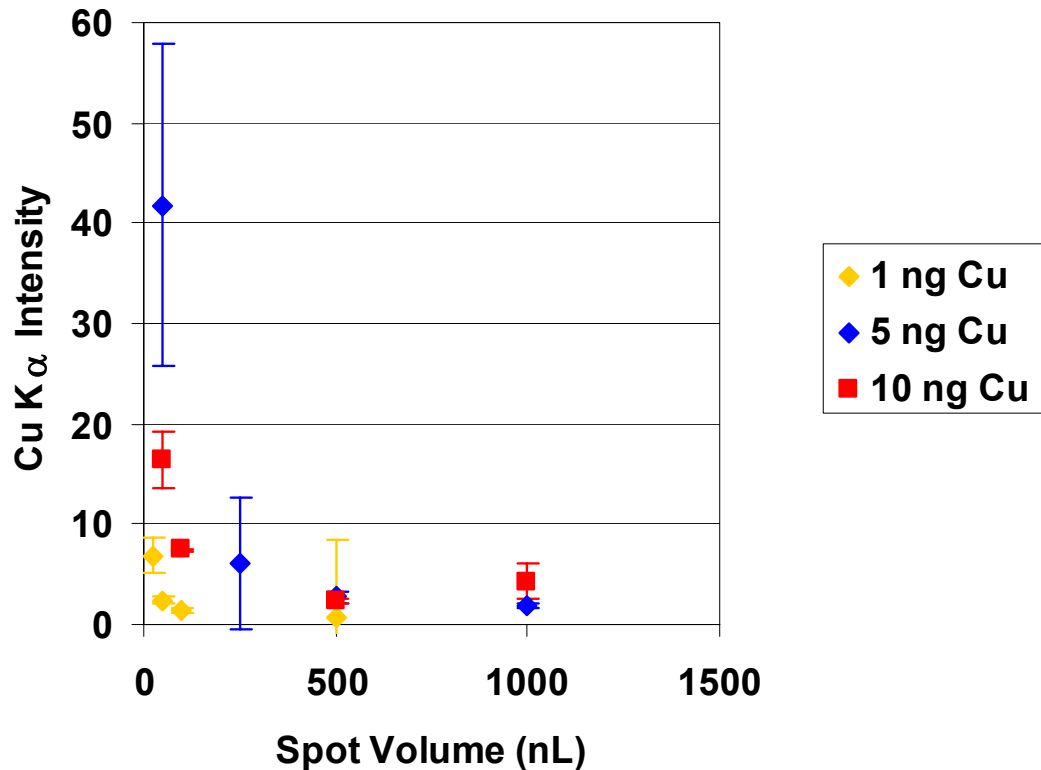

➤ **Cu intensity decreases with increasing spot volume for a given mass**

➤ **Smaller spot volumes allow for better mass detection**

MXRF Molecular Recognition

Cu Concentration (mg/L) Deposited

Spot
Volume

10 mg/L

100 mg/L

1K mg/L

10 K mg/L

1000 nL

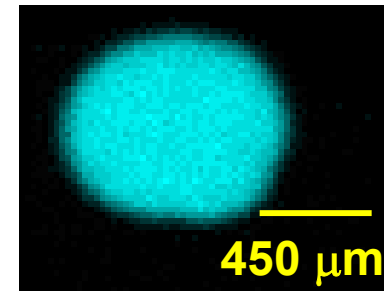
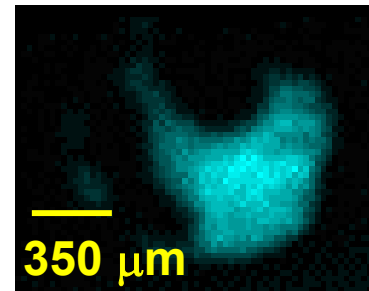
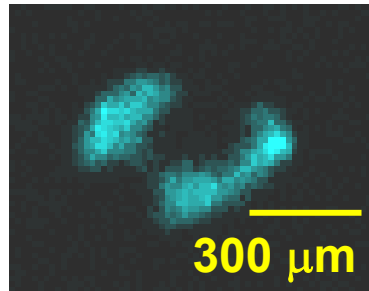
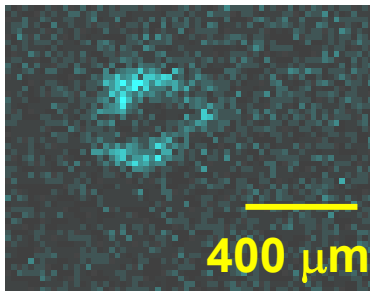

10 nL

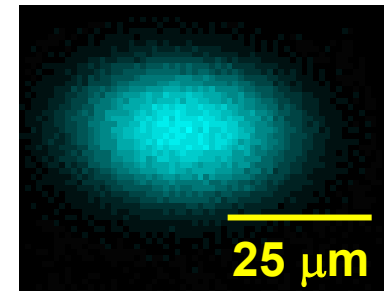
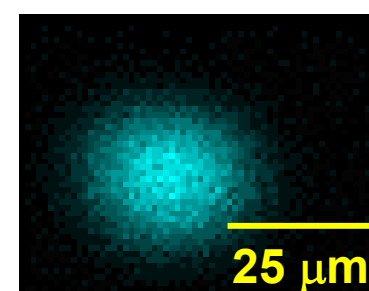
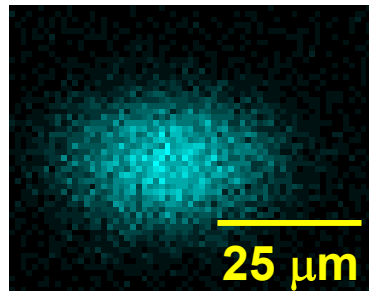
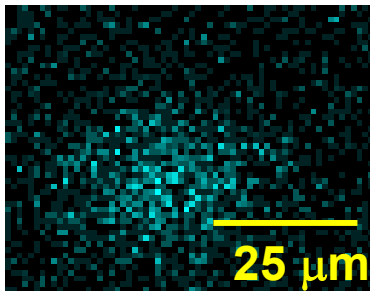

- Drying pattern of smaller droplets is more circular and uniform
- Less concentrated spots are most affected by larger spot volumes

MXRF Molecular Recognition

Effect of X-ray Beam Size on Apparent Dried Spot Size

X-ray Beam Diameter:

70 μm

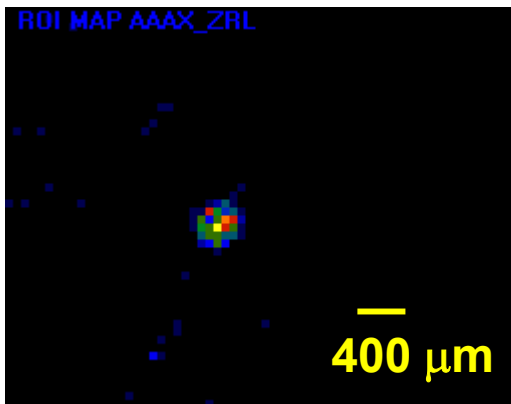

200 μm

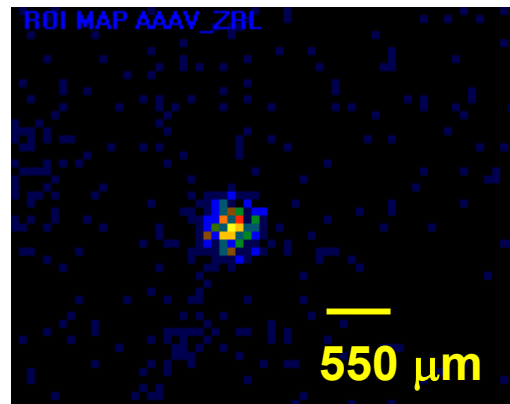

350 μm

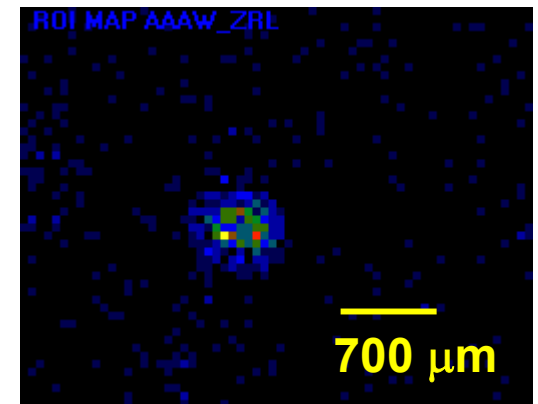

- All spots: 10 ng Zr, 10 μL spot volume
- Spots were deposited with a 10 μL transfer pipette on polypropylene film