

Building Nest Structures, Feeders, and Photo Blinds for North Dakota Wildlife

by
Chris Grondahl
and
John Dockter

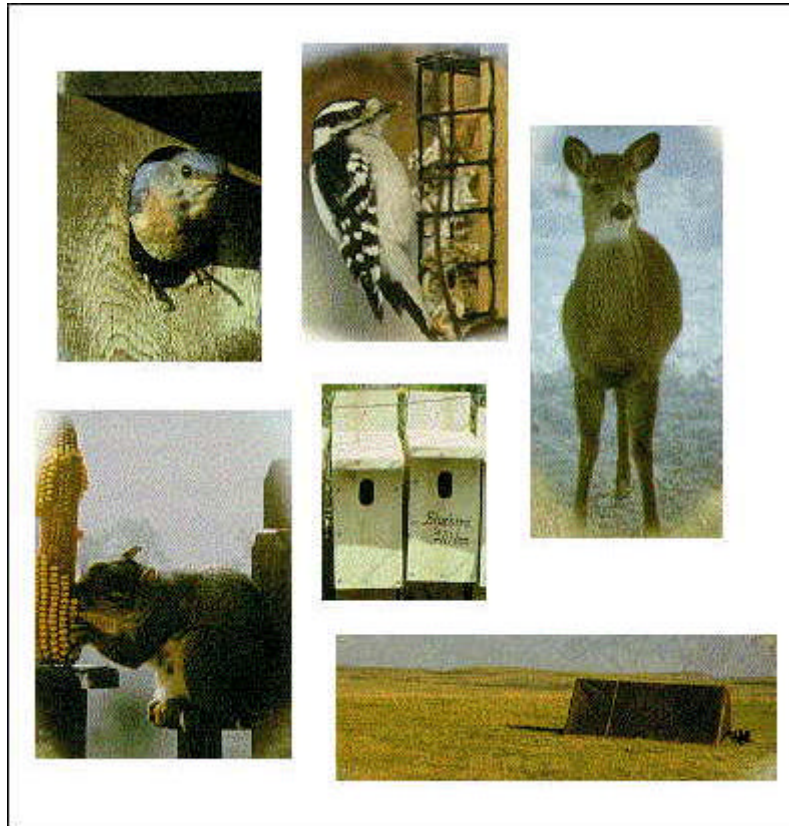

State Game and Fish Department
100 North Bismarck Expressway
Bismarck, North Dakota 58501-5095

Table of Contents

[Introduction](#)

[Section 1 -- Nest Boxes and Nesting Platforms](#)

- [House Wren, Black-capped Chickadee, White-breasted Nuthatch](#)
- [Tree Swallow and Eastern Bluebird](#)
- [Peterson Bluebird House](#)
- [American Robin and Barn Swallow](#)
- [Purple Martin House](#)
- [Northern Flicker Nest Box](#)
- [American Kestrel, Northern Screech-owl, Gray Squirrel, Red Squirrel, and Fox Squirrel Nest Box](#)
- [Burrowing Owl Nest Tunnel](#)
- [Small Bat House](#)
- [Johnson Bat House](#)
- [Wood Duck and Hooded Merganser Nest Box](#)
- [Raccoon and Common Merganser Nest Box](#)
- [Entrance Hole Sizes for Songbird, Woodpecker, and Squirrel Nest Boxes](#)
- [Canada Goose Nest Platform, Turtle and Duck Loafing Platform](#)
- [Canada Goose Nest Tub](#)
- [Culvert Nest Structure](#)
- [Mallard Nest Basket](#)
- [Hen House](#)
- [Mourning Dove Nest Basket](#)
- [Great Blue Heron Nest Platform](#)
- [Entrance Hole Sizes for Duck, Merganser, and Raccoon Nest Boxes](#)

[Section 2 -- Feeders](#)

- [2-Liter Plastic Soda Bottle Bird Feeder](#)
- [Milk Carton Feeder](#)
- [Large Self-Feeder](#)
- [Linda Tray Feeder](#)
- [Hardware Cloth Suet Feeder](#)
- [Dowel Suet Feeder](#)
- [Barrel Feeder for Wildlife](#)

[Section 3 -- Predator Guards](#)

[Section 4 -- Wildlife Viewing and Photography Blinds](#)

- [Low-Profile A-Frame Blind](#)
- [Modified Portable Fishhouse-Type Blind](#)

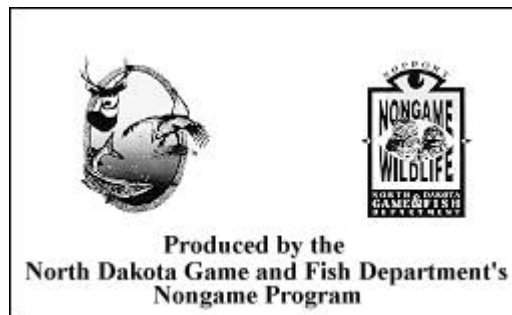

Credits

Thanks to Carrol L. Henderson of the Minnesota DNR for contributing artwork from *Woodworking for Wildlife*. Thanks to Linda Roeder for organization and layout of this publication.

Photos

by Chris Grondahl and Harold Umber

Introduction

Providing nesting areas, feeding, and watching wildlife are becoming increasingly popular sports in North Dakota. These activities generate about 18 million dollars annually to our state. More importantly, these pastimes provide hours of relaxation, entertainment, and enjoyment for both young and old alike.

This publication introduces some types of nest structures, feeders, and photo blinds which can be constructed in your home at a minimal expense.

There are four sections to this publication. The first covers nest boxes and platforms. These structures are meant to enhance existing habitat or provide a nest structure where none presently exists. This does not mean that natural habitat is not important. Dead and dying trees which provide nesting cavities are still the best type of habitat available.

The second section describes wildlife feeders. Feeding birds and mammals in the winter can be good for both you and wildlife. First, it provides you a pastime and viewing opportunity during the cold winter months. Secondly, wildlife may have difficulty finding adequate food and this additional source can help them survive the winter. Remember, planting a crop for feed is just as good, or better, than grain in a feeder.

Section three is a short description of predator guards which are very important additions to any wooden support post.

The final section describes two types of homemade photo blinds which can be made with minimal effort or dollars spent. If you've never tried a photo blind, you may be surprised at the results.

Nest Boxes and Nesting Platforms

General Information for Nest Boxes and Nesting Platforms

Providing nesting areas for wildlife is a popular and growing hobby for many North Dakotans. Building houses according to the proper specifications, placing them in the right habitat, and maintaining them can benefit both bird and mammal populations. If they are not monitored for detrimental species such as the house sparrow, they may actually do more harm than good.

It is important to realize that not all birds and mammals nest in cavities. Many birds, like the American robin or meadowlark, either build cupshaped nests in trees or nest on the ground. The nest box plans that are found in this publication are specific to wildlife that utilize a cavity, either within a dead or dying tree or a man-made structure such as a nest box.

Cavity nesting birds will accept any kind of nest box that they can enter. Before deciding on what kind of nest box to build, there are considerations which should be taken--the size of the entrance hole, interior dimensions, proper ventilation, and the capability to open the nest box for monitoring and cleaning. Do not construct a box for "birds" in general as most species require different sized houses and entrance holes. The following guidance and construction plans will provide specific plans for most North Dakota species.

For all practical purposes, wood is the only appropriate building material to use. Wood is a natural material with good insulating properties. Plastic and metal often overheat. Green "pressure-treated" lumber is impregnated with copper arsenate as a preservative. If the chemical is not applied perfectly, the wood is toxic to birds and humans. Exterior grade plywood contains dangerously high levels of formaldehyde and therefore is also not the best choice. The best woods to use are rough cut cedar or redwood. They naturally resist deterioration when exposed to sun and rain and the weathered look is inconspicuous and attractive.

Never paint or stain the inside of a nest box. If you want to paint the exterior, close up the box and paint only what you can see. Use an exterior grade latex paint and give the top a second coat. Choose a light shade which reflects most heat or a natural color such as green, tan, or gray. A heavy grade of linseed oil stain works well also. Houses that blend in with their surroundings are more appealing than brightly painted boxes and less likely to draw the attention of human vandals.

Nest boxes can be mounted in several ways. They may be attached to existing wood or metal fence posts, power or telephone poles, existing trees, or on wood or metal posts or pieces of pipe used specifically for this purpose. Utility poles are often suitable for mounting nest boxes; however, permission should be obtained from the utility companies before this is done. Discretion should also be used before mounting to trees. Do not place bird boxes designed for bluebirds on trees because this invites competition from too many other species.

Predator-proofing should, be considered for all bird nest boxes that are not mounted on steel fence posts or pipe. A piece of sheet metal, tin, or used aluminum plates from newspaper offices serve well to prevent predators from climbing wooden posts. Sheets should be stapled or screwed on around the outside of the wood post be at least 12 inches high. The bottom of the guard should be at least two feet above ground level.

Do not put perches on any bird houses. Only the unwanted house sparrows and starlings prefer perches. If house sparrows or starlings begin nesting in a bird house tear out the nest material as these species are not protected by state or federal law. Nests may need to be removed numerous times before these birds abandon their efforts.

**House Wren*, Black-capped Chickadee*,
White-breasted Nuthatch**



Note: Entrance hole diameter is 1 1/8".

(An entrance hole diameter of 1 1/4" is needed for the white-breasted nuthatch.)

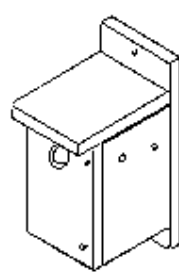
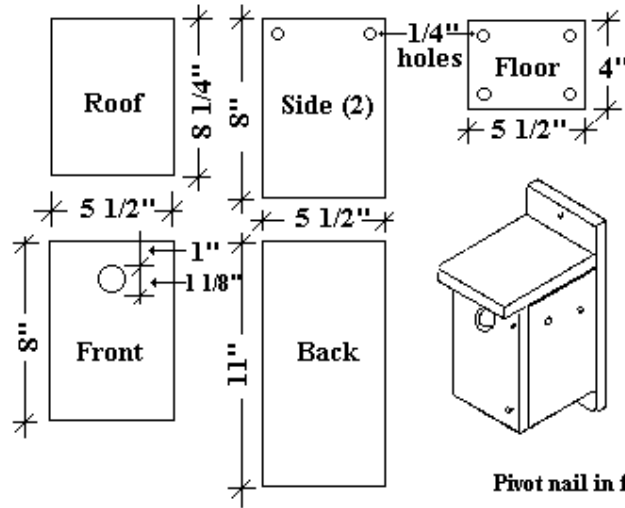

Pivot nail in front.

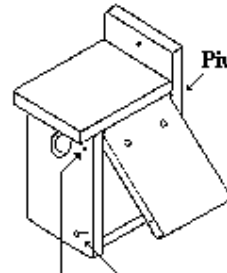

Pivot nail in back.

Use one nail or screw at bottom to hold door closed.

Lumber: One 1" x 6" x 4'0".

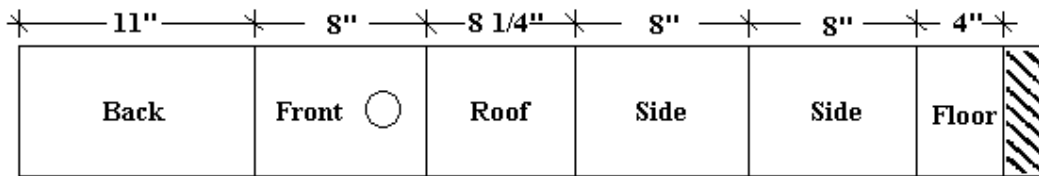

*Please note that any birdhouse entrance 1 1/4 inches in diameter or larger will admit house sparrows! All wren and chickadee nest boxes should have an entrance hole of 1 1/8 inches in diameter.

↑
Save!

Tree Swallow and Eastern Bluebird

Eastern bluebirds nest throughout North Dakota. The best habitat consists of areas comprised of short grasses with nearby fence posts, high line wires, or sparse trees where birds can perch. Bluebirds normally will not nest within city limits or farmsteads where competition from house sparrows is intense. For best results, nest boxes should be placed in pairs about 10-25 feet apart and 100-200 yards between pairs. They should be put 4-6 feet above the ground on steel posts or wood posts with predator guards. The entrance hole should face in a general northeast direction to prevent sun from shining in and over-heating the box.

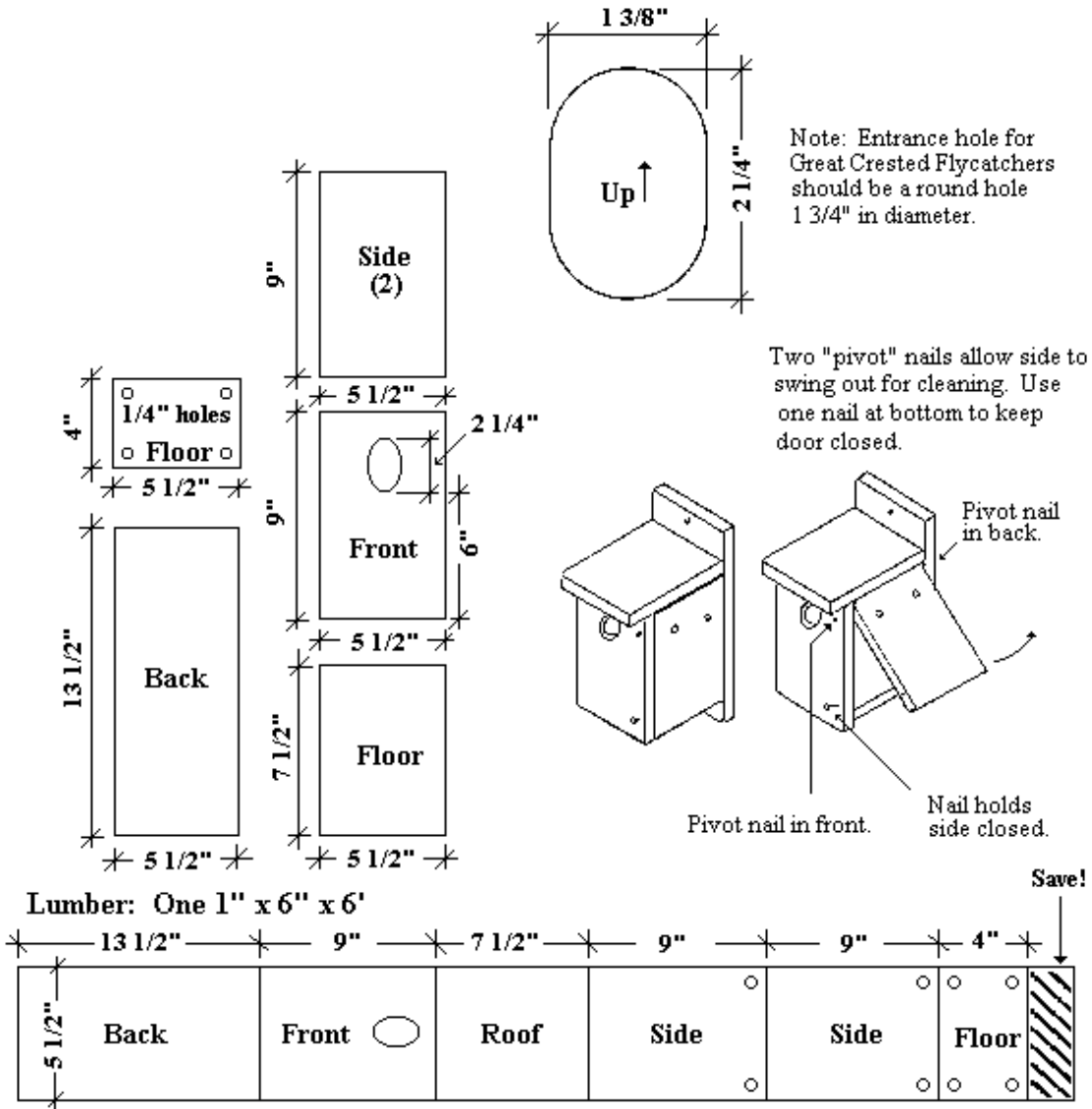

Peterson Bluebird House (continued)

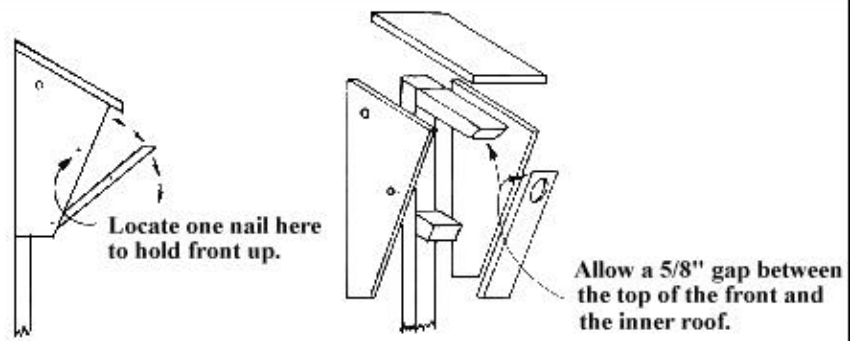

A. The Peterson house has seven parts and is assembled in this order:

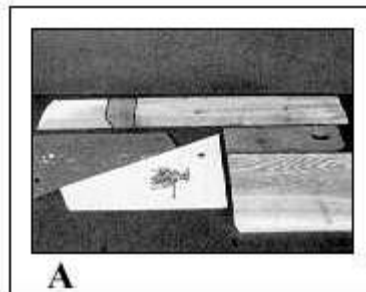

B. The inner roof is toe-nailed to the back.

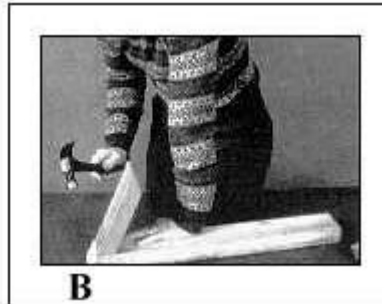

C. Then the floor is toe-nailed to the back.

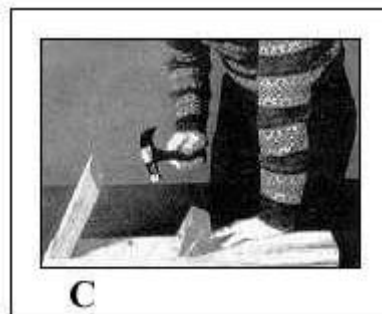

D. Third, one side is nailed to the resulting frame.

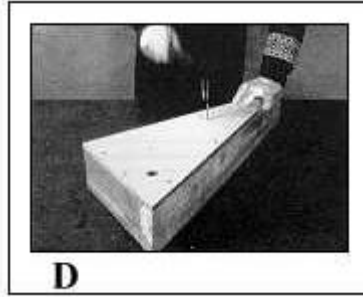

E. Then the other side is nailed to the frame.

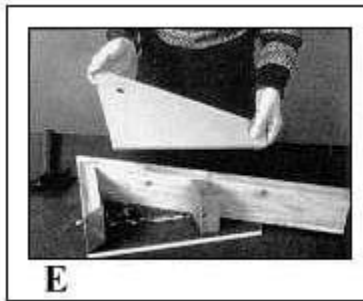

F. Next, the swing-down front is fastened by a nail into each side. A third nail is pounded part way into the side near the entrance hole. This is removed each time the house is checked.

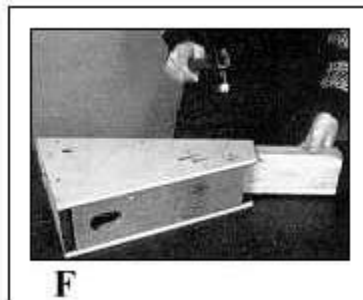

G. Finally, the outer roof is nailed on top.

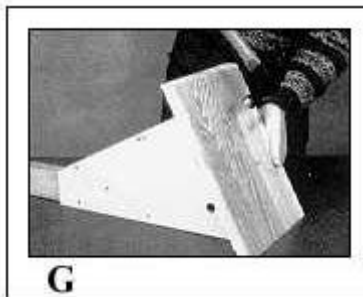

Editor's Note: -- *Good sanitation and maintenance of the nest box at the end of the breeding season are your best defenses against ectoparasites and other insects. To repel blowflies, wasps and ants during the breeding season, some researchers recommend using a pyrethrin insecticide as the safest pesticide.*

American Robin and Barn Swallow

The American robin is one of the most commonly known urban birds and is a joy to welcome back in the spring. A shelf as described below can be placed on the wall near a window where the birds can be observed throughout the nesting season or to a tree trunk or post 6-10 feet above the ground. Barn swallows will also utilize this shelf structure and may be encouraged to nest away from a doorway or other inconvenient location if presented with this opportunity.

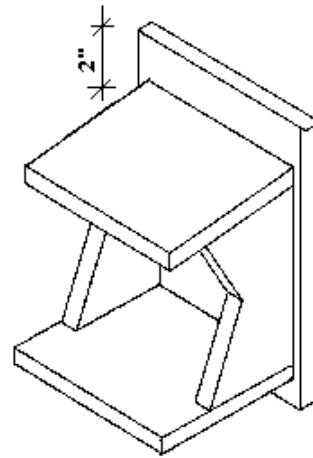
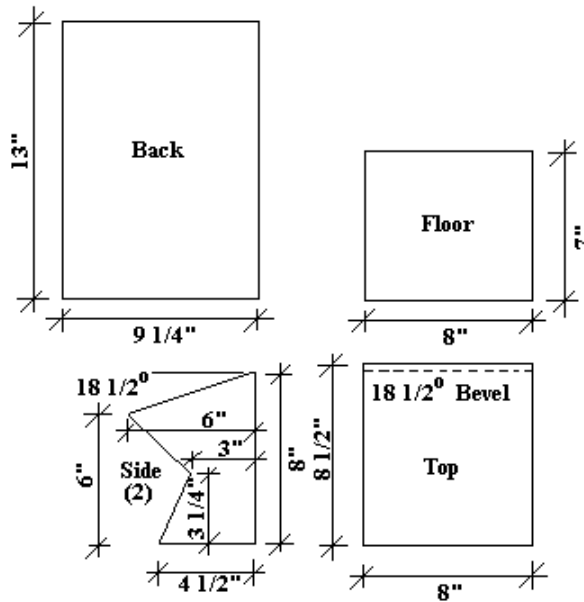

Lumber: One 1" x 10" x 4'0"

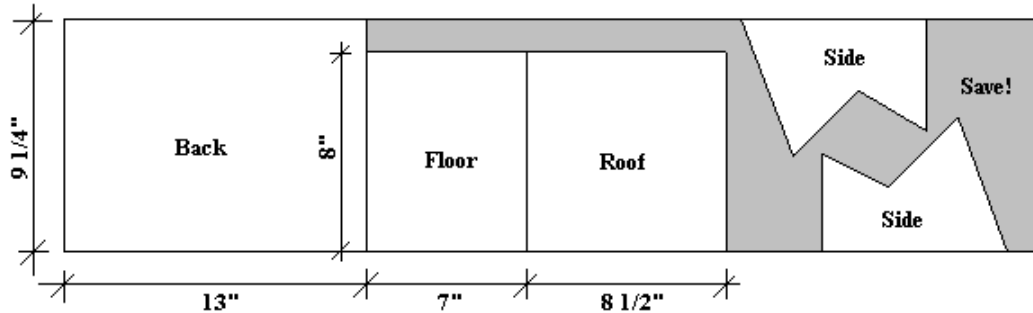

Purple Martin House

Attracting this insect eating bird is one of the biggest challenges for any backyard bird enthusiast. As the first martins arrive in mid-April, remove the entrance covers to the house which kept out starlings and sparrows during the winter. Ensure that your house is in an open area at least 30 feet away from trees and open on all sides. Martin houses should be at least 8 feet above the ground and painted white to reflect the sun. Houses need to be cleaned out after each season. House sparrows must be controlled if you are to be successful since the house sparrow is the martin's worst enemy.



Materials:

4' x 8' x 1/4" plywood
 2" x 2" x 6" for chimney
 1" x 2" x 14' for base
 1" x 1" x 8' for corner blocks
 4" x 8" metal window screen
 4" x 4" x 14' cedar post

Place 1/2" dowel railing around balcony to keep young from falling.

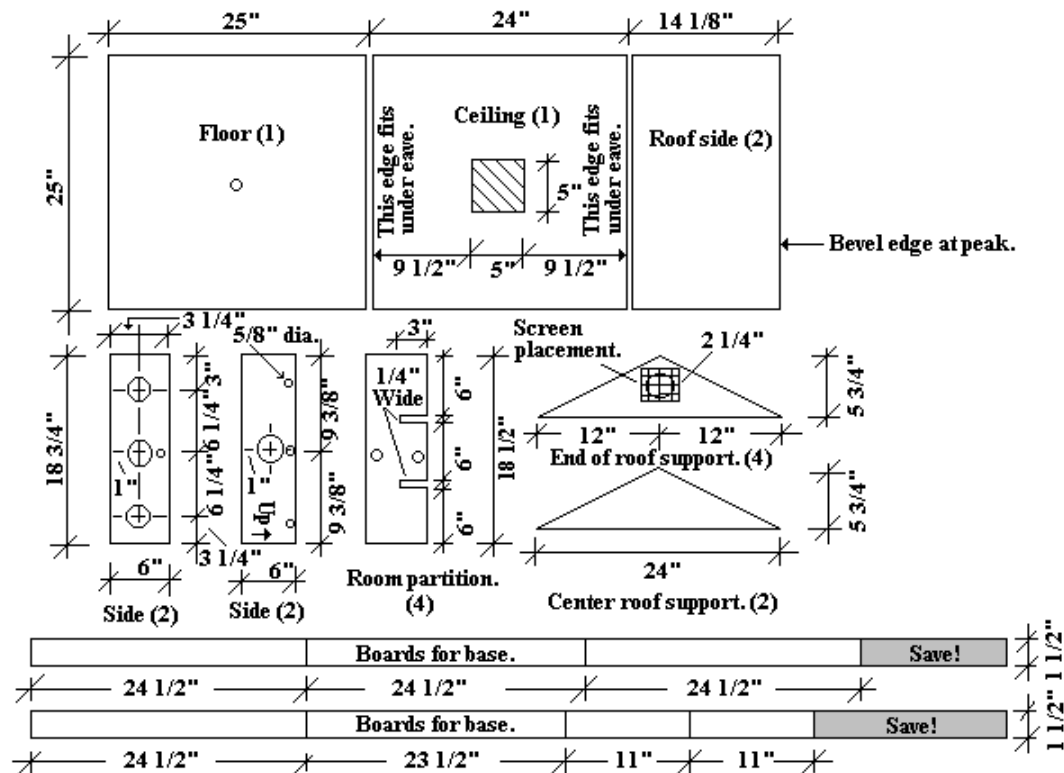

Purple Martin House

(continued)

CONSTRUCTION

Note: This unit is held together by a threaded rod extending from the underside of the 1" x 2" base frame through the center of the chimney.

1. Mark all pieces on plywood sheet, then cut them out. Make four 1" x 1" x 5/8" corner blocks and eight 1" x 1" x 2" blocks to position the parts.
2. Cut out and assemble base from 1" x 2". Use 7d galvanized siding nails. Attach floor piece to base with glue and 1" or 1 1/4" nails.
3. Assemble the sides, alternating three hole and one hole pieces. Use glue and 1" nails or 3/4" #6 flat head wood screws. Use three at each end of each piece.
4. Position first-story sides on base piece. Mark position for each 1" x 1" x 2" block to hold side in position. Attach blocks to floor with glue and two 1" nails or 3/4" #6 flat head wood screws. Place completed sides in position on floor. Insert partitions. Position ceiling and mark for the location of 1" x 1" x 2" blocks near corners on the underside. Attach the blocks.
5. Place ceiling in position.
6. Glue pairs of end roof supports together to form gable ends 1/2" thick. Attach screen. Position and mark. Glue the two center roof supports together to make it 1/2" thick. It will be positioned adjacent to the threaded rod going up through the exact center of the house. Attach these pieces to the ceiling with glue and nails or flat head wood screws from the underside. Attach roof sides with glue and nails or screws.
7. Make chimney from a piece of 2x2. Cut V-notch on end to fit roof. Have it extend 2 1/2" above roof peak. Drill 1/4" hole in chimney and roof for rod. Nail chimney in place. Insert rod and tighten up.
8. Drill hole in top of pole to accommodate nut on lower end of threaded rod.
9. Use 1/2" diameter maple dowels to make a fence about 2" high on each balcony. Pieces of wood 1" x 1" x 3" may be used as the corner posts of this railing.

This pattern shows how to cut out a martin house from one sheet of plywood.

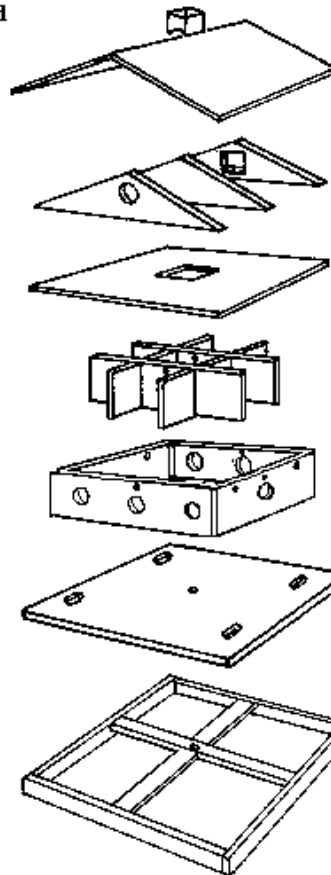
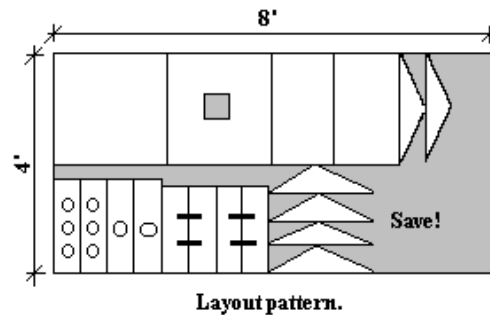

Expanded view of martin house. A threaded rod inserts through the base and up through the chimney.

Entrance hole diameter: 2 1/4"

Locate 5/8" ventilation holes 1" below top edge of sides.

*For sides, measurement from floor to center of entrance holes = 2 1/8"

Northern Flicker Nest Box

The flicker is a common woodpecker in North Dakota distinguished by its yellow tail feathers and red patch on the back of the head and neck. They nest in wooded areas and in town. Flickers are excavators and are more likely to use a nest box if it is completely filled and packed with sawdust. This simulates a dead tree with a rotting inside. Boxes should be attached to a post and placed 4-6 feet high. A 1 1/2" thick rough cut cedar material is preferred.

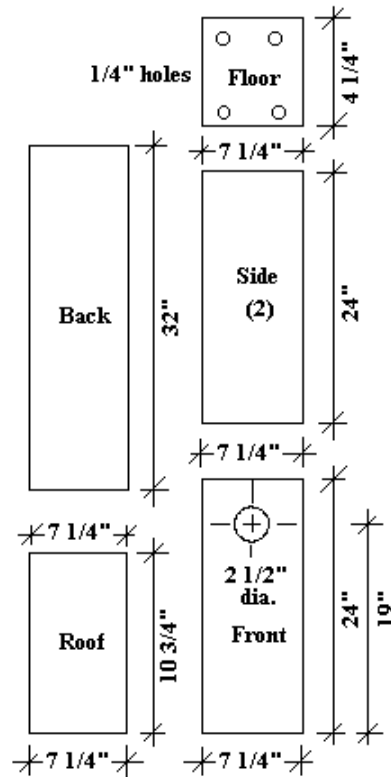

Hinge or cleat roof for cleaning.

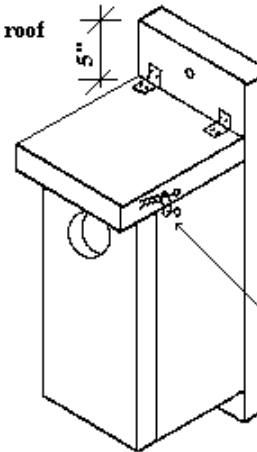

Wire box shut.

Fill box to top with sawdust.

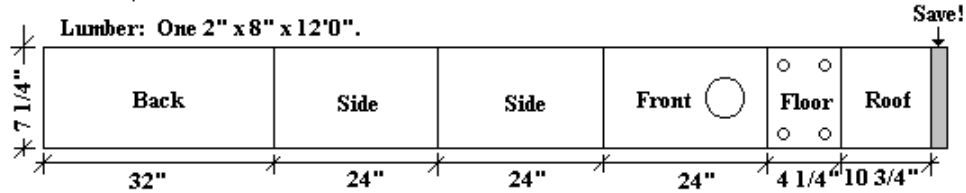

American Kestrel, Northern Screech-owl, Gray Squirrel, Red Squirrel, and Fox Squirrel Nest Box

To attract kestrels, place the box in relatively open country on a tree or post 10-30 feet high with grassy habitat nearby. Screech-owls can be attracted along the edges of hardwood forests adjacent to fields or wetlands. Boxes should be placed at least 10 feet high. Both the kestrel and owl boxes should include a predator guard to keep squirrels from using the nest boxes. Squirrels can be attracted by using this box and filling it half full of leaves and mounting at least 30 feet above the ground on a tree at least 10 inches in diameter. It is not necessary to clean out squirrel boxes.

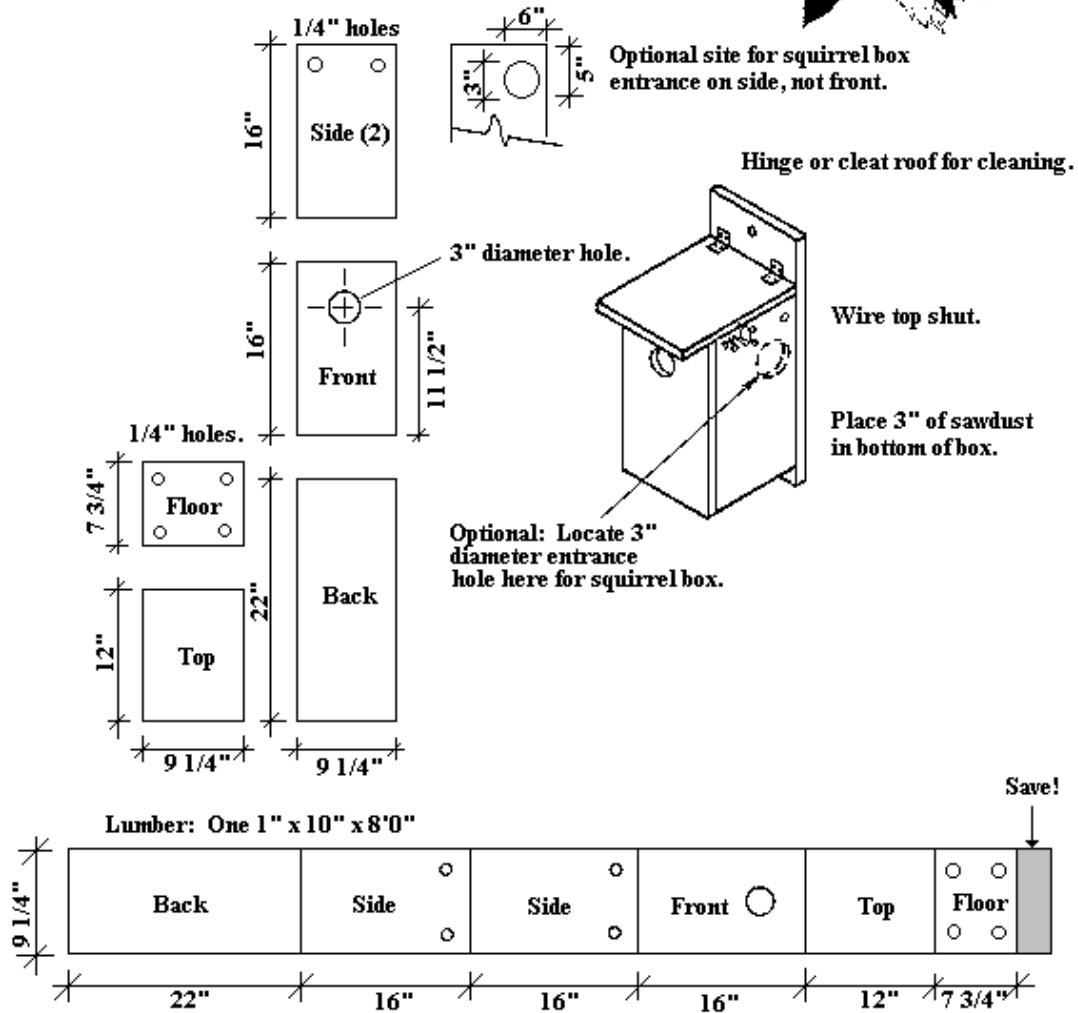

Burrowing Owl Nest Tunnel

Burrowing owls were historically found throughout most of the mixed and short grass prairies of central and western North Dakota. They utilize burrows created by ground squirrels, prairie dogs, fox, coyote, and badger. Because of the loss of large tracts of native prairie to agricultural practices, much of the potential and stable burrowing habitat was also lost. The plans discussed below can be used to provide a nesting site on native prairie where natural burrows may not exist. Owls prefer areas with short grass where visibility is good. Dimensions below will be suitable for ungrazed pastures, however, 1 1/2" wood may be necessary in pastures where cattle or horses will be stepping on top of the structure. Bury the structure 6" below the surface. A mound of dirt built up around the entrance will simulate the mound of dirt around natural dens and aid in attracting owls. Success has been documented using this structure in western North Dakota.

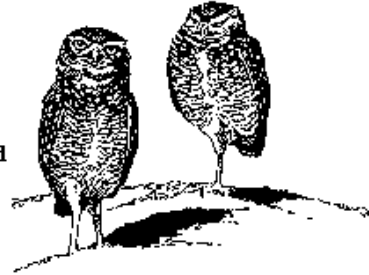

Bottom view of roof with roof cleats.

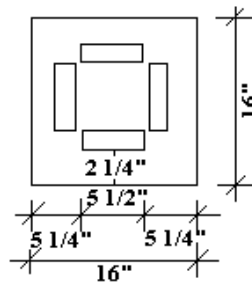

Lumber:

- One 1" x 6" x 8'
- One 1" x 6" x 10'
- One piece of 1/2" exterior plywood 24" x 48"

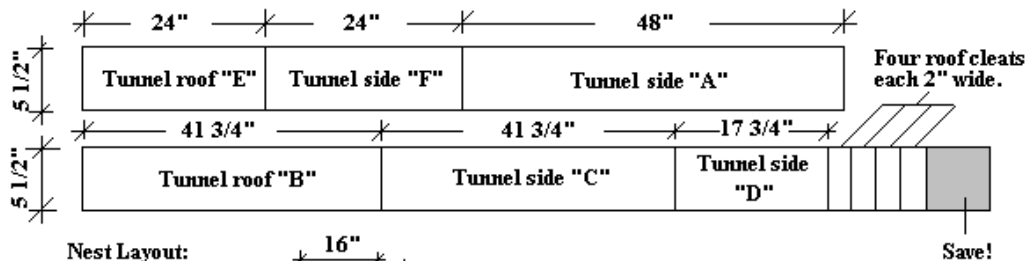
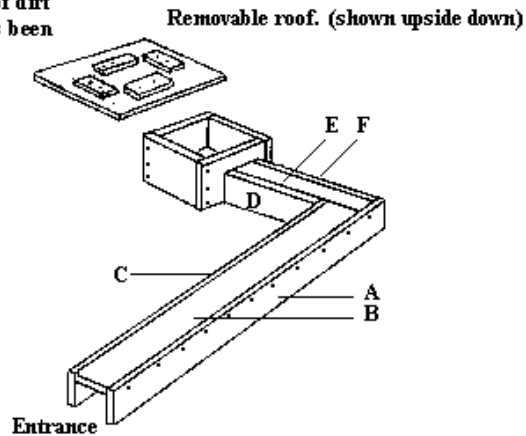

Nest Layout:

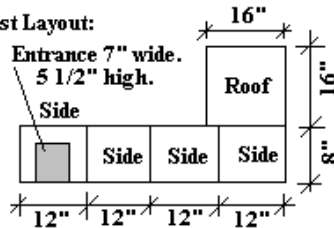

Select site on high, well-drained area. Bury nest box and tunnel 6" below ground surface. entrance should simulate a badger den entrance.

Small Bat House

Nine species of bats can be found in North Dakota but the little brown bat is the most common. Bats are insect eaters and may eat over 1,000 insects each evening. They require a warm, moist environment which reaches 80-90 degrees during the daytime. This can be achieved by covering part of the house with tarpaper. Painting with black may also help. Houses should be hung on trees, poles, or the sides of buildings which have a good open area on at least one side for bats to maneuver while flying. The best habitat is close to rivers, lakes, or marshy areas where insect populations are high. Nest boxes should be about 12-15 feet above the ground.

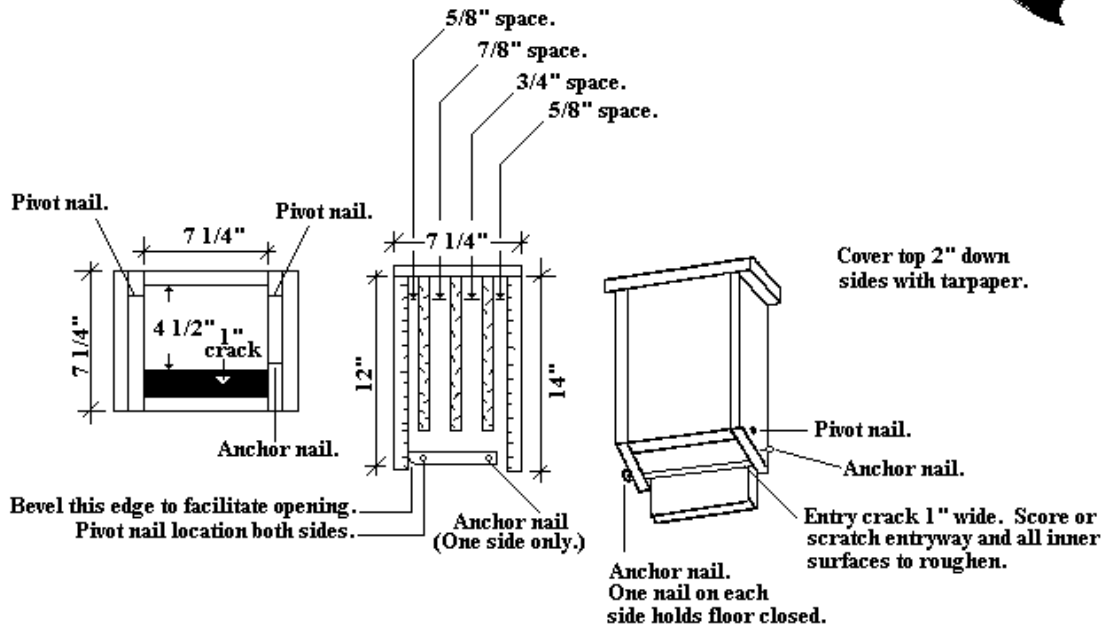

Bottom view. Side view (Cut away.) Front view as mounted on building.

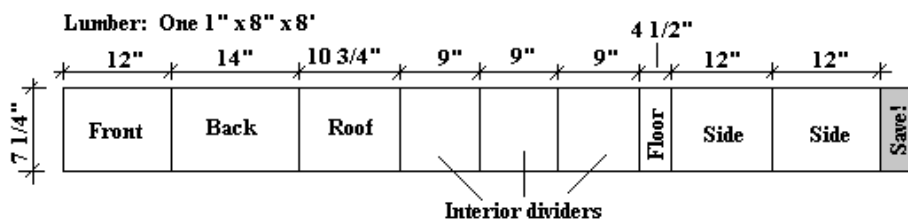

If you have success using a bat house, please contact our Department's Natural Resource Division.

Johnson Bat House

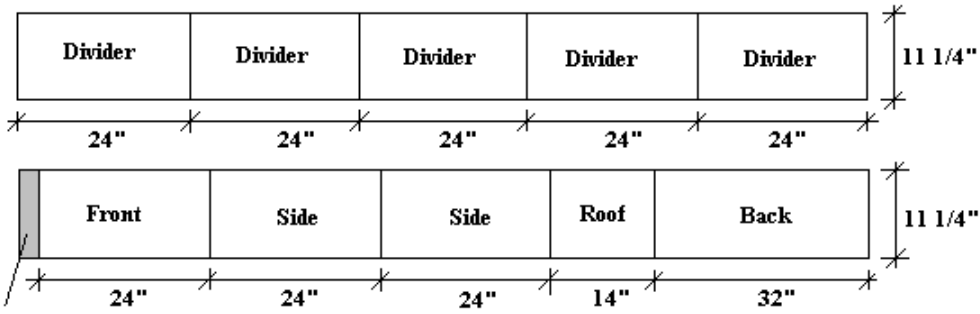
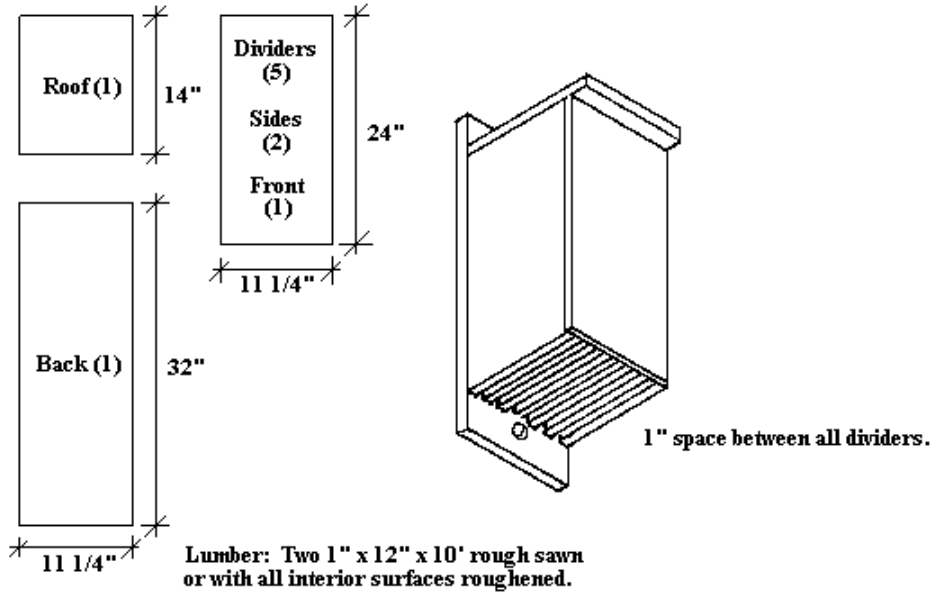

Save!

Note: All external seams and joints should be caulked if not tight fitting. Divider boards are spaced 1 inch apart.

Wood Duck and Hooded Merganser Nest Box



Wood duck populations have made a significant come back during the past 20 years, in part because of adding additional cavity nesting habitat in the form of boxes such as the one described below. Boxes should be placed over water or in woodland habitat within one-half mile of a wetland. Since

a female wood duck must lead her newborn young from the house to water, the path should be free of major man-made obstacles like street curbs, highways, or tightly woven wire fences. Boxes placed over water should be 6-8 feet above the water's surface. Boxes placed in woodland habitat should be at least 20 feet high. At least 3 inches of mixed sawdust and wood chips should be put into the bottom of the box. The top of the box should be wired down to prevent raccoons from entering. It is important to attach a 1/4 inch wire mesh inside the box and below the hole so young ducklings are able to crawl out upon hatching. Entrance holes should be 3 inches high and 4 inches wide.

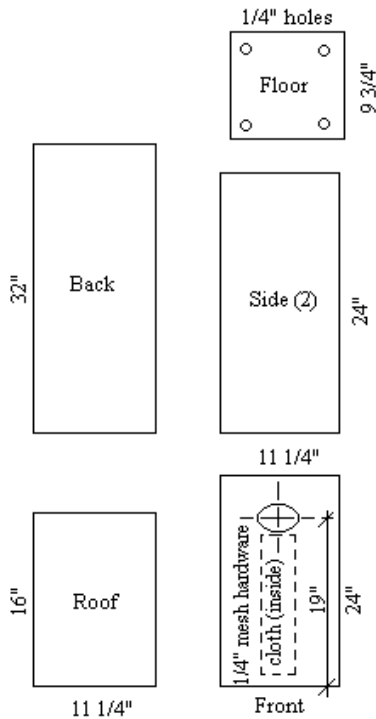

Hinge or cleat roof for cleaning

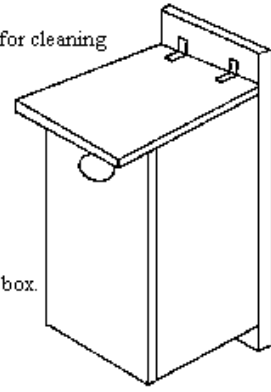

Place 3-5" of sawdust in bottom of box.

Lumber: One 1" x 12" x 120"

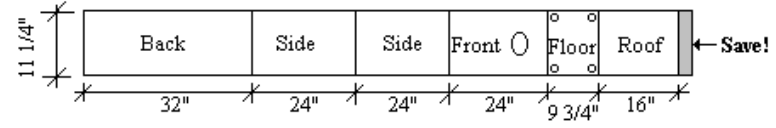

Raccoon and Common Merganser Nest Box



Pileated woodpecker 4" diameter round hole.

Hole sizes for common merganser and raccoon, see:

Entrance Hole sizes for Duck, Merganser, and Raccoon Nest Boxes

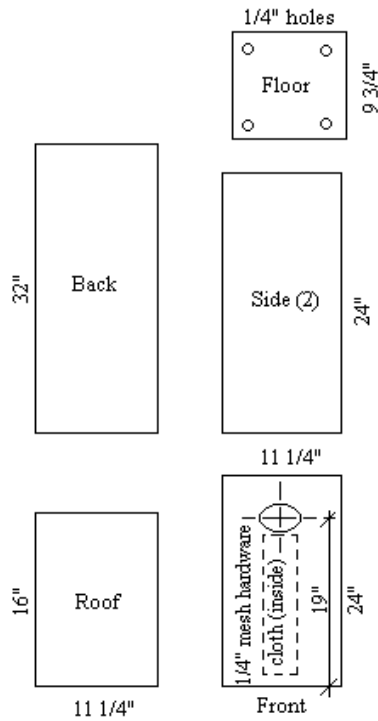

Fill box to top with sawdust for pileated woodpeckers.

For common mergansers, fill bottom of box with 3"-4" of sawdust.

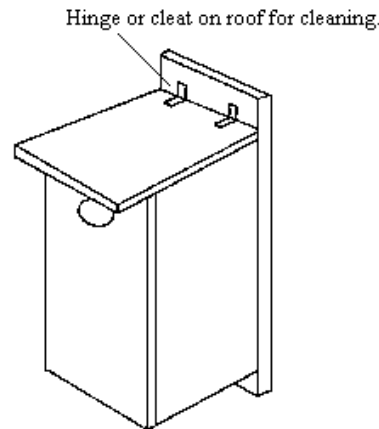

Lumber: One 1" x 12" x 120"

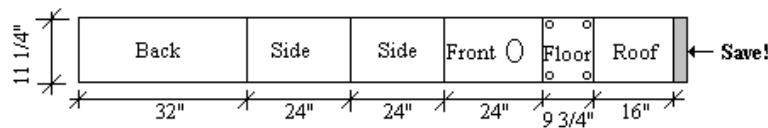

Entrance Hole Sizes for Songbird, Woodpecker, and Squirrel Nest Boxes (Actual size is shown)

Trace onto wood with carbon paper.

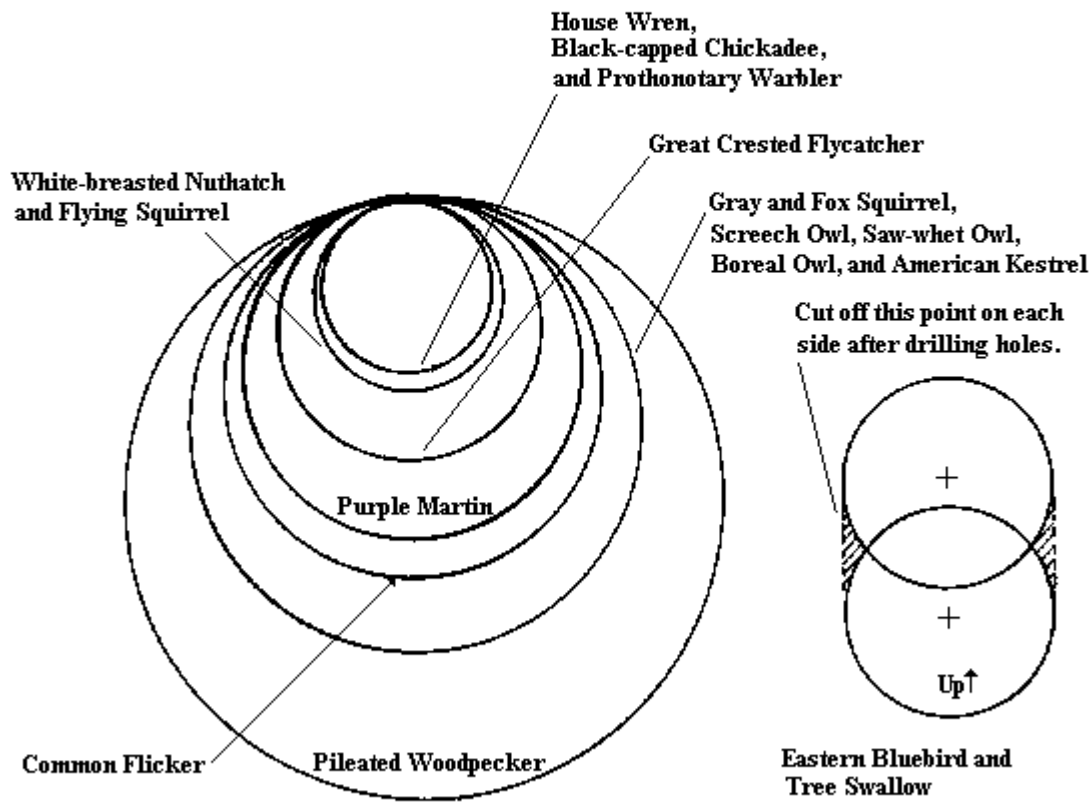

Drill two holes, 1 3/8" diameter
centered 7/8" apart.

Canada Goose Nest Platform Turtle and Duck Loafing Platform

The giant Canada goose has made a tremendous comeback in North Dakota in the past 15 years. Part of this increase has been due to artificial nesting structures. There are various types of structures that will attract nesting including a floating structure described below. Cut the material as shown and nail boards onto pole sections. Attach a washtub or 10" high section of 55 gallon drum to the platform. Drill drain holes through bottom of tub and cut an escape hatch 6" wide and 4" high just under the top of the tub. This is for young geese to exit the tub. Paint the tub an earth tone color and fill 1/3 full with nesting material such as grass or hay. Anchor the platform in 2-4 feet of water. Nesting structures should be at least 200 yards apart if they are in view of one another. This will prevent territorial conflicts.

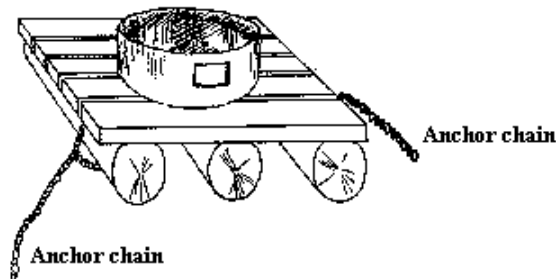

Materials:
 One 8" diameter cedar pole - 12' long.
 Four 2" x 6" x 8' boards.
 One 22" diameter round metal washtub.
 Do not use washtub for turtle and duck loafing platform.

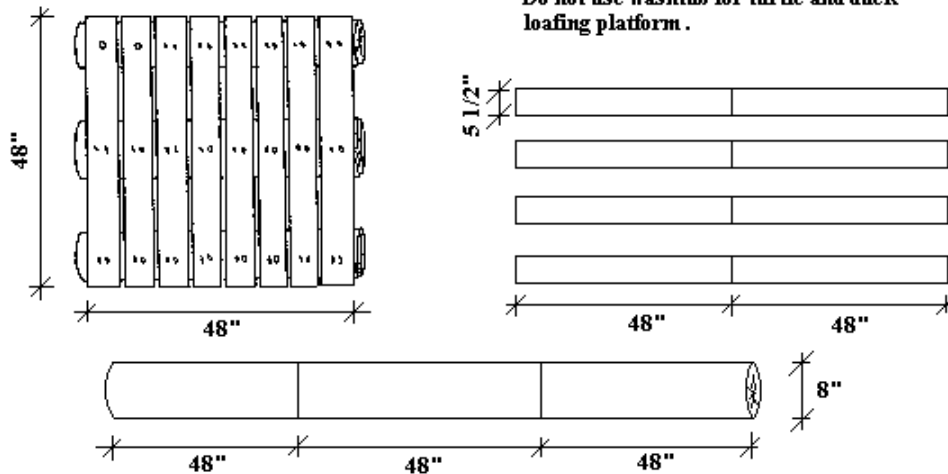

Nest Tub

A structure which has also proven to be effective in attracting Canada geese is the fiberglass nest tub. These tubs measure 32 inches in diameter and have an 8" sidewall with an additional 2" drop in the bottom of the tub. These structures are mounted on a 9 foot pipe after the pipe has been driven into the bottom of the wetland. The best time to erect these structures is during the winter when you can work on top of the ice.

Select a location where the water will be from 1 to 3 feet deep and, if possible, at least 50 feet from the shore. A stand of emergent vegetation such as bulrush is an excellent location. The pipe should extend out of the water at least 3 feet. Choose an area along the north or west shore or in a protected bay where it will be less apt to get pushed over by the ice action in the spring. More than one structure can be placed in a wetland as long as they are at least 200 yards apart. It also helps if the view from one to the other is obstructed. Nesting material should be placed in the tub by March 1 as Canada geese are early nesters. Put enough material into the tub so that it extends above the top.

Geese will not always find the tub the first year--do not be discouraged. Check to make sure the tub is filled with nesting material annually and that the tub has not been pushed over by ice.

Fiberglass baskets (tubs) for elevated goose nesting structures:

Fiberglass Unlimited, Inc.
South Highway 81
PO Box 1297
Watertown, South Dakota 57201-1297

Raven Industries, Inc.
Plastics Division
PO Box 1007
Souix Falls, South Dakota 57101-1007

Kenco Plastics Company, Inc.
State Highway 21
Necedah, Wisconsin 54646

Pleasure Products Manufacturing
2421 16th Avenue South
Moorhead, Minnesota 56560

Canada Goose Nest Tub

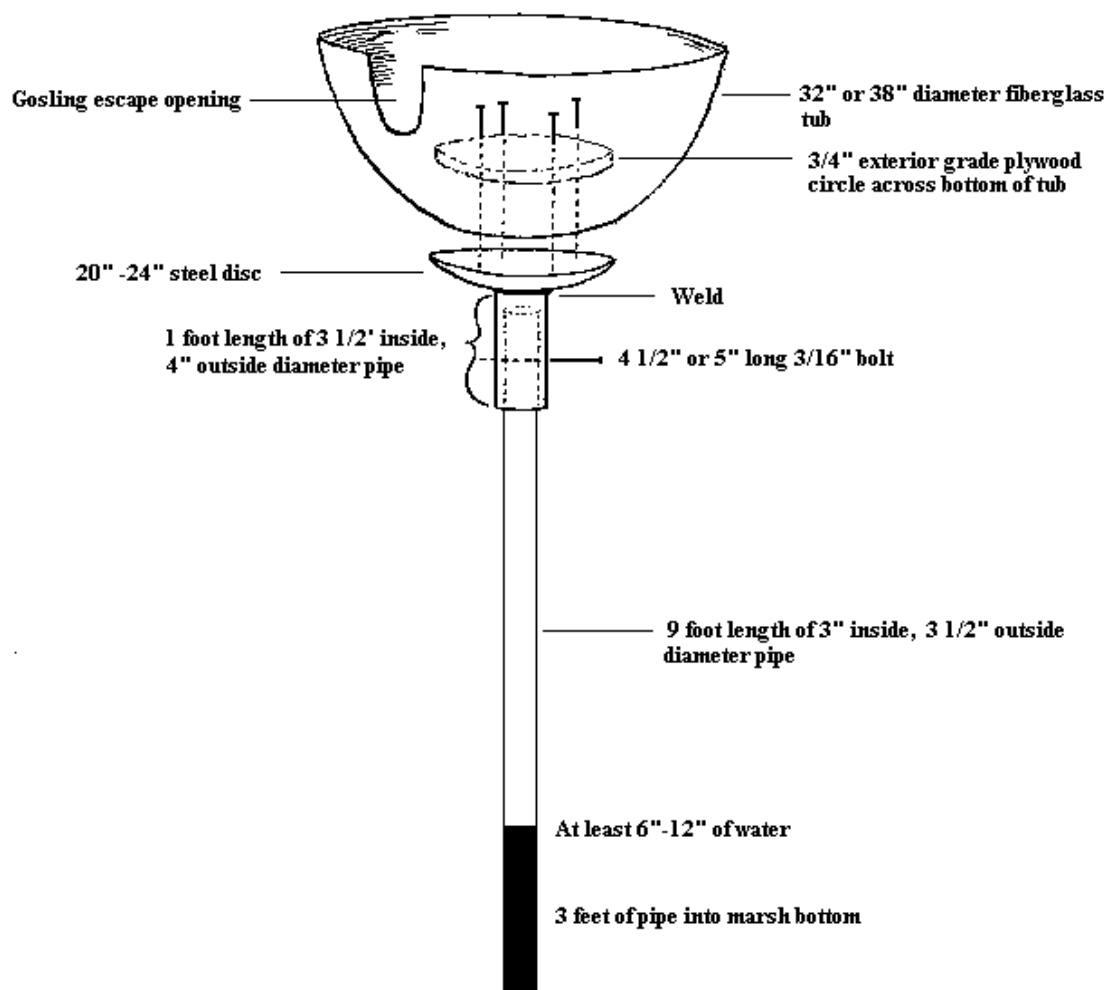

Culvert Nest Structure

A major downfall of most nest structures on private land has been that maintenance generally drops off with time. This causes structures like baskets to become useless, or even worse, death traps. Culverts, however, offer ideal nesting conditions and, if properly installed, require very little maintenance after the initial installation.



Fig. 2. Photo of culvert structure in a North Dakota wetland.

Location

Culverts are best suited for Type IV wetlands, followed by larger Type IIIs and sheltered areas of Type Vs. Culverts should be placed within six feet of emergent vegetation in a water depth of approximately 18 inches in the spring. One structure per 10 to 20 acres is a good goal and there should never be more than one per wetland acre. Areas with nearby trees should be avoided because they provide hunting perches for raptors and crows.

Installation

(Culverts of 1.5-1.8 m in height are preferable.) A culvert can be either installed in a dry wetland or through the ice. Installation in a dry wetland is much easier and less hazardous than through the ice. To install in a dry wetland, scrape a depression in the wetland bottom with a loader bucket. Using the bucket, push down and square the culvert in the depression. While installing through the ice, use good judgment as to what the ice conditions are. If ice is thick enough to support the equipment, start by cutting a hole in the ice. Cutting a hole in the middle of the circle of ice will make it easier to lift out. Once the ice is removed, push the culvert down into the mud and level it. Try to get the culvert into solid (but not frozen) bottom substrate.

Filling the Culvert

Culverts should be filled with soil suitable for plant growth. Rock or gravel are not acceptable fill material because they do not allow moisture to reach growing plants. The soil will settle and the culverts must be revisited to replenish the settled soil. The soil can settle as much as two feet, making it impossible for ducklings and goslings to escape. Filling the culvert with water saturated fill material may decrease the settling. Plan on revisiting the site(s) at least once and probably twice to replenish the settled soil.

Habitat/Cover

Culverts grow a variety of weeds from windblown or soil-stored sources. This is generally okay, but seed such as alfalfa, sweet clover, and native grasses could be spread into the soil to improve conditions. It generally takes 1 to 2 years before cover is adequate to attract nesting waterfowl. Nesting geese usually break down nearly all residual vegetation and use it as nest material. They also destroy the vertical and horizontal cover that attracts mallards. Generally geese and mallards will not occupy the same sight unless modifications are made. A partition may be placed into a larger culvert that separates geese and mallard nesting sights. The partition can be made from cedar boards (4 cm thick) to resist rot. Covering the partition with 15 cm mesh wire will allow mallards to squeeze through the mesh if necessary. A rounded opening of approximately 15 x 20 cm will provide access to the covered quadrants of the partition. Weaving 1-2 cm diameter willow sticks through the wire mesh on the side facing the open goose nesting area will ensure that the cover for the mallard nesting sight will not be incorporated into the goose nest.

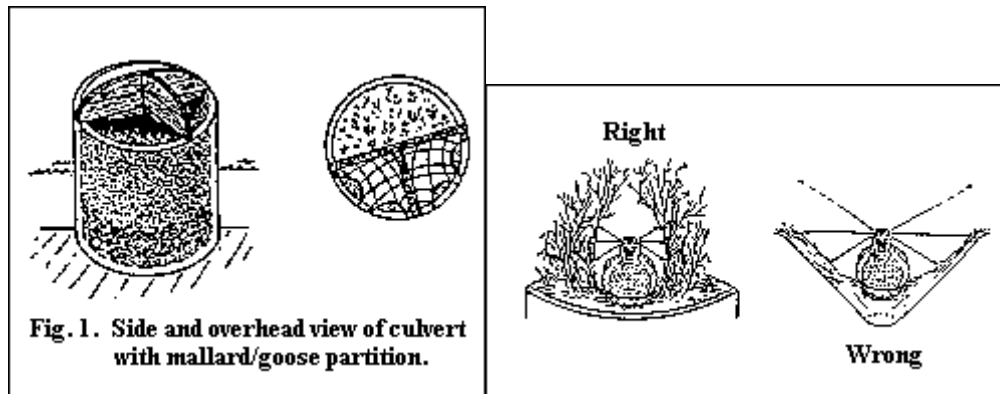

Mallard Nest Basket

This nest basket, similar to the design of a fiberglass goose tub, can be constructed to attract nesting mallards. The frame is made of 1/4" diameter steel rods mounted on 1" diameter steel support pipe. This pipe telescopes inside a 1 1/2" steel pipe with a set screw to establish the desired height. Baskets should be placed in wetlands where water is 2-4 feet deep and where water will remain until at least mid-summer. The basket should be at least 10 feet from shore and 3-5 feet above the water line. Baskets should be filled with flax straw or other suitable material and placed within areas containing some cattails or bulrush. It is easiest to place these nests during the winter, through the ice. They will need to be maintained annually before the nesting season.



Materials:

- 8' support pipe, 1 1/2" diameter.
- 2' 2" basket pipe, 1" diameter.
- 13' 6" steel rod, 1/4" diameter.
- 3' x 3' hardware cloth, 1/2" mesh.

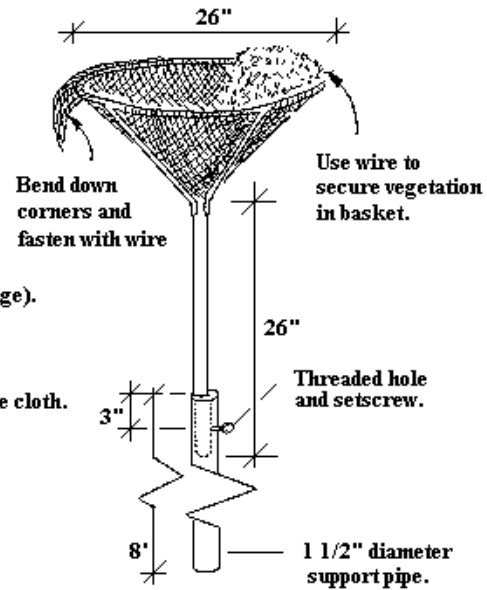
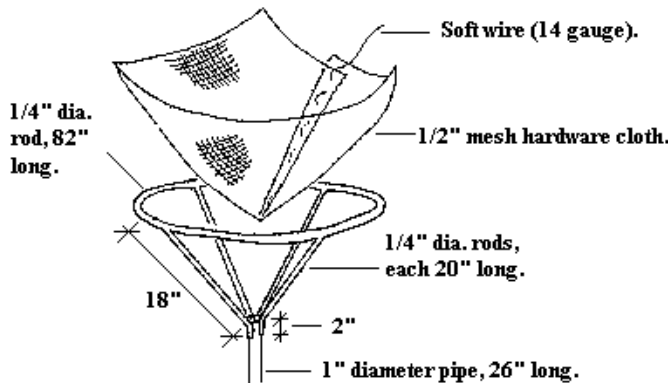
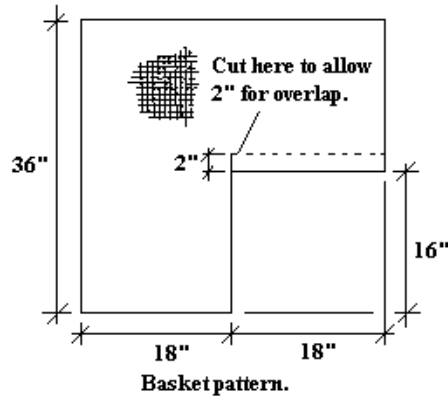

Hen House

The basic design of the hen house is a three foot long grass cylinder. The hen house is easy to build and all the materials are readily available.

Materials to build a hen house include:

- 7 foot piece of 2" x 2" mesh welded fencing wire 36" wide or 1/4" hardware cloth
- 1" x 6" x 3' treated lumber
- 10 foot long 2" pipe
- wire
- four screws
- pipe flange
- flax, marsh grass

To make the cylinder, cover one-half of the fencing wire with an inch of grass and roll it into a foot diameter cylinder.

Take short pieces of wire and tie the roll together in two or three areas. Use screws to attach the flange onto the center of the board.

Attach the cylinder to the board with pieces of wire about five feet long, weaving the wire through the cylinder and attaching it to the board. Repeat this two or three times to make sure the cylinder is on tight.

Pound the 10 foot pipe into the bottom of the wetland to make sure the pipe is stable and secure. About three feet of pipe should be left out of the water. The nest is then attached to the pipe with a flange. Installation of nests should be done in late winter when pounding the pipe into the wetland bottom and attaching the nest can be done easily. Hen houses should be placed at least 100 feet apart because hens are territorial and are intolerant of other ducks nesting in close proximity.

Inner and outer parts of cylinder made of 2" x 2" mesh welded fencing wire or 1/4" hardware cloth rolled to approximately one foot outside diameter, with flax straw or grass rolled between the rolls.

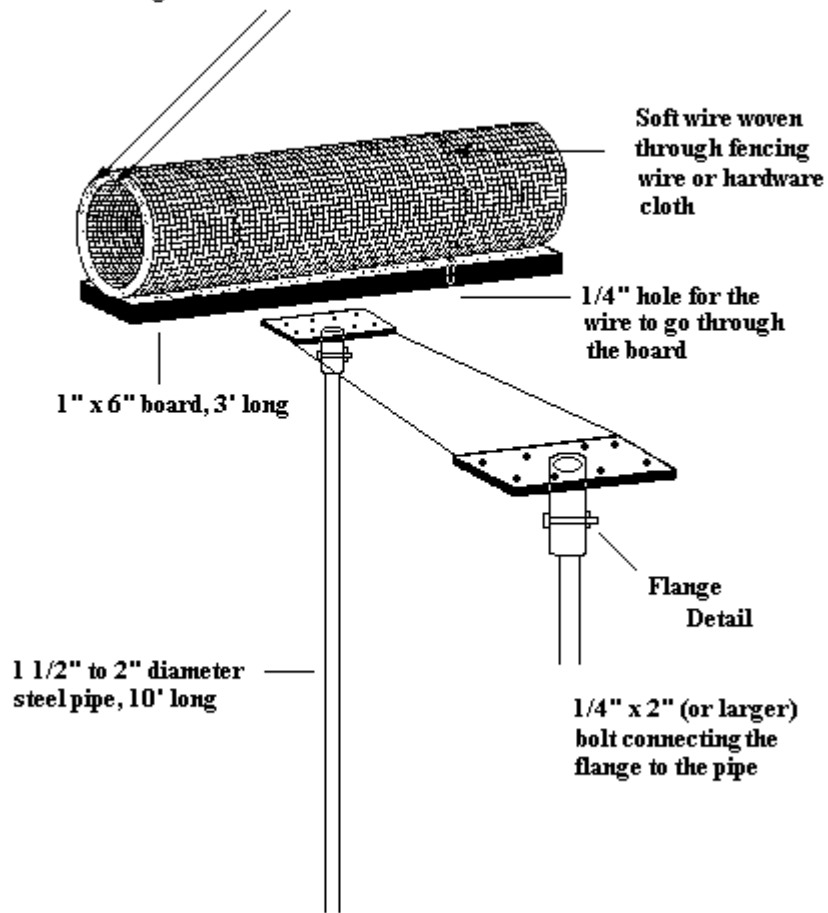

Mourning Dove Nest Basket

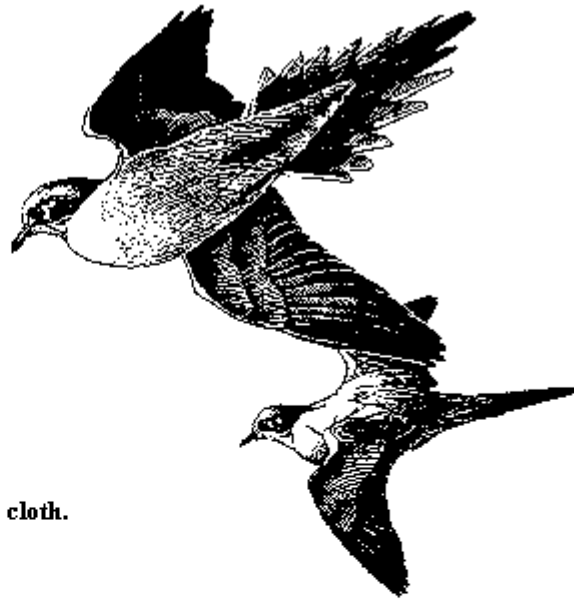

Materials: One 12" x 12" piece of hardware cloth.

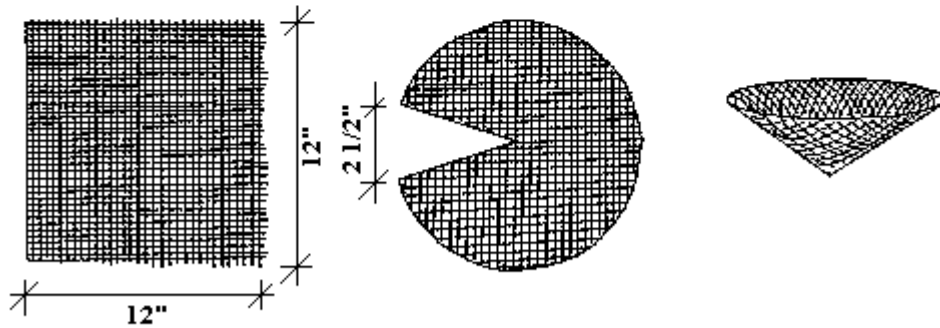

Cut with tin snips to form a circle. Cut out a narrow pie-shape and wire edges together to form a cone. Wire and/or staple cone into the crotch of a tree limb.

Great Blue Heron Nest Platform

The great blue heron is an elegant water bird found throughout North Dakota. It is most commonly found nesting near rivers, lakes, or other water bodies that contain live mature or dead trees. Here, herons construct a nest of sticks at least 20 feet high. They nest in colonies, meaning there are many heron nests within one small area. Nest platforms should be used in the vicinity of a present colony or to enhance an existing one where trees are deteriorating.



Support poles should be 30 feet high and 6-8 inches in diameter. Three nest platforms can be placed on each pole. The first is at the top and the other two staggered at 180° and 4 feet intervals. Placement of heron platforms is best conducted through the ice from January through March.

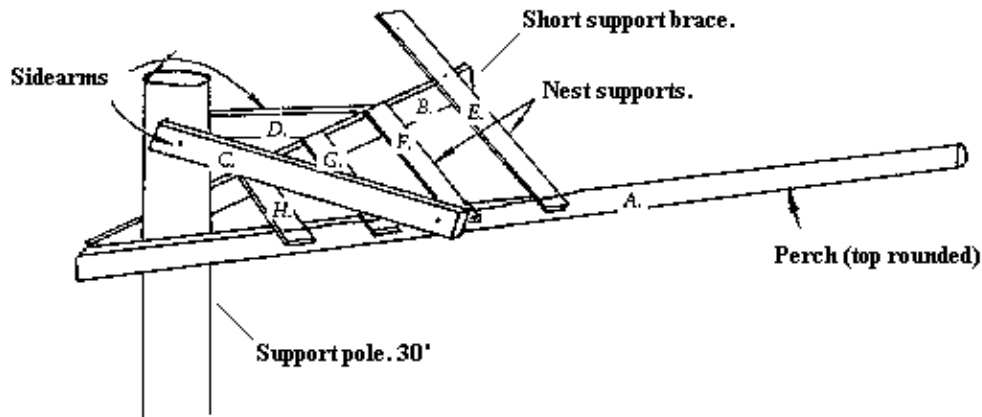

Lag screws should be used to attach platform to pole.

Lumber:

- A. 2" x 2" x 7'.
- B. 2" x 2" x 30".
- C. 1" x 2" x 26 1/2".
- D. 1" x 2" x 26 1/2".
- E. 1" x 2" x 39".
- F. 1" x 2" x 19 1/2".
- G. 1" x 2" x 19 1/4".
- H. 1" x 2" x 17 7/8".

Position sidearms on support pole so nest is inclined upward at approximately 7 degree angle.

Wire armful of sticks on lath nest supports to stimulate use.

One 30' cedar support pole/three platforms.

Entrance Hole Sizes for Duck, Merganser, and Raccoon Nest Boxes (Actual size is shown)

Trace onto wood with carbon paper.

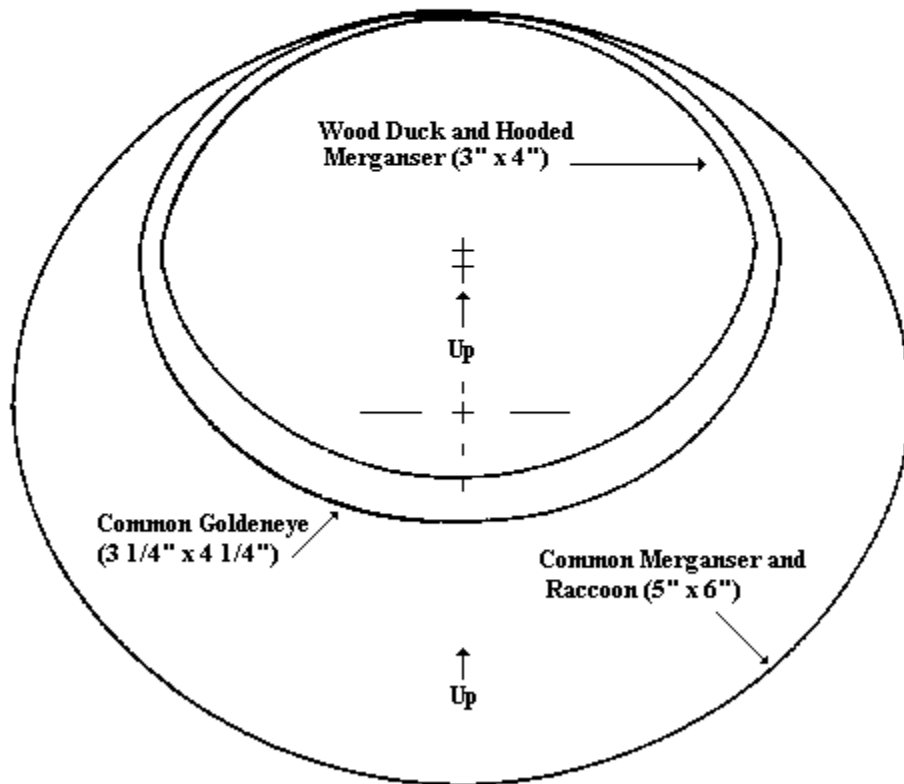

Feeders

General Information for Wildlife Feeders

Feeding birds can provide entertainment and enjoyment for people of all ages. You can attract birds to your backyard throughout the year but the most important time to help the birds is during the winter. Cold temperatures and snow limit the food available and put extra demands on birds to keep warm. In the spring and summer, birds feed on insects which are plentiful. Feeding should be restricted to feeders and not simply thrown on the ground.

Once you begin feeding during the winter, don't stop. Birds become dependent on a food source and may not locate an alternative once you stop feeding. There are a variety of seeds and foods that attract birds. The development of black oil sunflower seeds revolutionized bird feeding. It is the single favorite and most nutritious food for birds. Adding specialty foods to feeders will attract even a wider variety of birds. In the summer, for example, sugar water attracts hummingbirds. Fruit brings northern orioles, waxwings, blue jays, and thrashers. Meal worms can lure in bluebirds. In the spring and fall, thistle seed will attract the Harris' sparrow and red-breasted nuthatch. A mixture of black sunflower and thistle attracts evening grosbeaks, red polls, and pine siskens during the winter. Niger thistle attracts purple, house, and goldfinches all year long. Suet will be utilized regularly by woodpeckers, nuthatches, and chickadees.

Placement of your feeder is as important as what feed you put in it. First, consider where you want to watch your birds. Is it by a window, on a glass door, or on the second story? Pick a location that is easily accessible for filling with food and out of the wind. Also consider the mess that empty and spilled seeds will cause below the feeder. Finally, keeping unwanted predators such as stray cats away from your feeder is important. Cats kill millions of songbirds annually and should be prevented from climbing near feeders. Locate your feeder at least 4-5 feet away, from overhanging tree limbs, fencing, or other structures.

This practice may also prevent squirrels from climbing on the feeder. The addition of a predator guard on the support pole may also prevent unwanted visitors. If squirrels still persist at a feeder, lure them to the other side of the yard with an easily accessible tray of peanuts.

Check your feeder for cleanliness if you use a tray or platform type. A dirty feeder may cause disease or discourage birds from coming. If you have trouble attracting birds, try adding a water source. Local bird populations will fluctuate, however, and birds absent for a period of time should not concern you.

Added attractions to your backyard can be lured in with additional types of feeders. The barrel type feeder described is excellent for attracting deer, turkey, pheasants, and cottontail rabbits if filled with corn, sunflower, and oats. You may also attract wood ducks or other waterfowl if you are located in the appropriate area.

2-Liter Plastic Soda Bottle Bird Feeder

2-Liter Plastic Soda Bottle Bird Feeder

1. Remove bottom and label.
2. Drill $1/8$ " hole in bottom (or heat wire).
3. Install wire.
4. Drill $5/16$ " holes for dowels (or cut).
- 5a. For niger or thistle, drill $1/8$ " hole then pull drill $1/4$ " to make slot (or cut).
- 5b. For black oil sunflower, drill $5/16$ " holes (or cut).

Use $5/16$ " round hole for sunflower or $1/4$ " x $1/8$ " slot for niger/thistle.

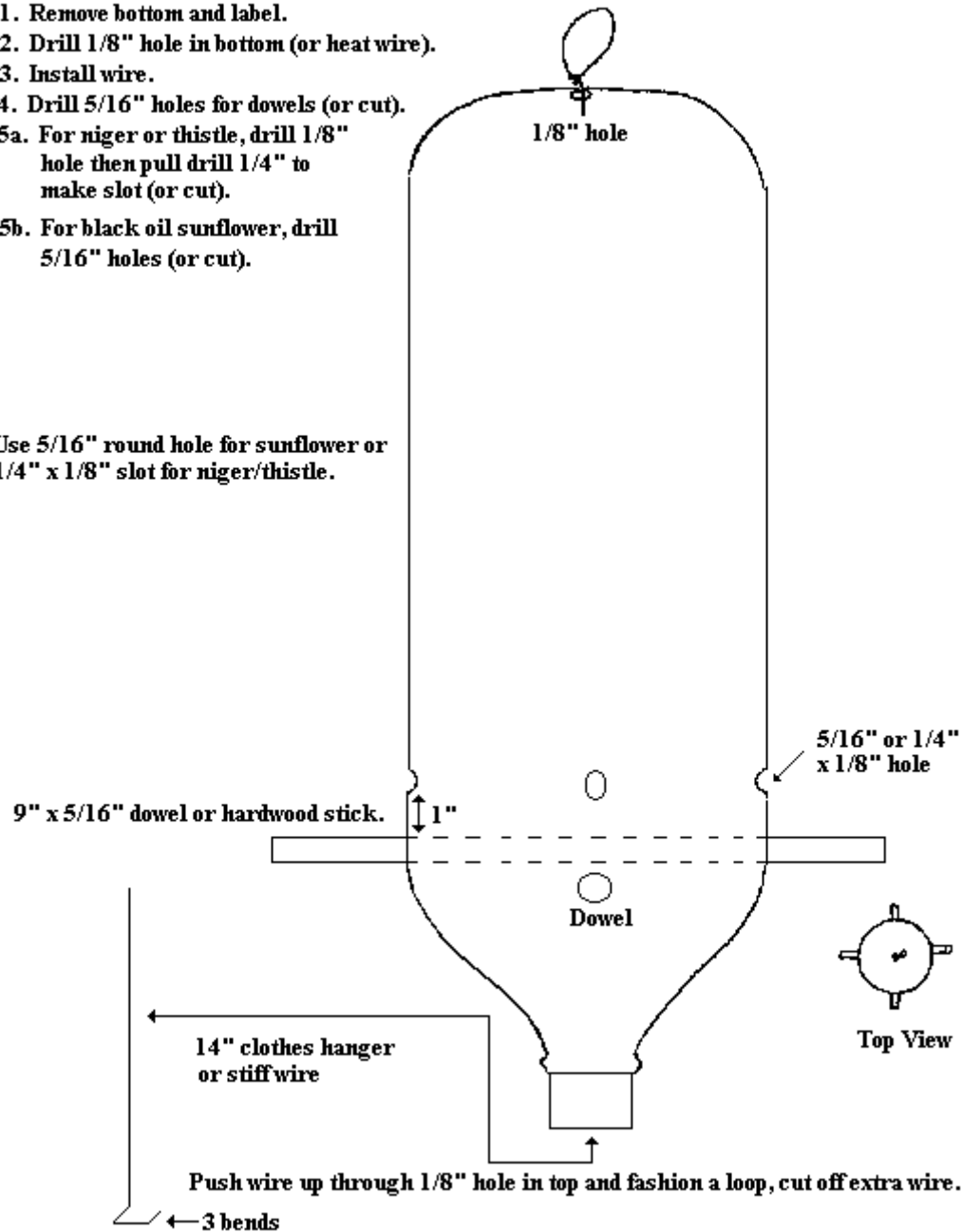

Milk Carton Feeder

by Alice J. Turner

Feeder A

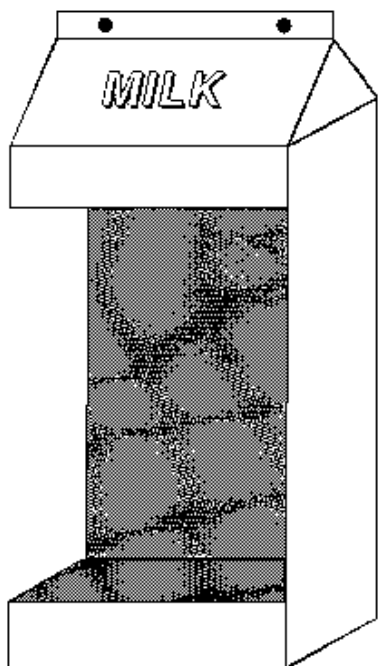

Empty one-half gallon milk cartons can be turned into a variety of bird-related items. To make a bird feeder, you can cut away two adjoining sides of a carton, leaving two inches at the top and bottom. You will have two solid sides (see Feeder A). Another plan is to cut windows in all four sides of the carton, again leaving about two inches at the bottom (see Feeder B).

Next punch two holes in the top of the carton. Thread some strong string through the holes and tie it, making a loop for hanging. Now you can put the feeder wherever you want. Both of these designs can also be used as bird baths.

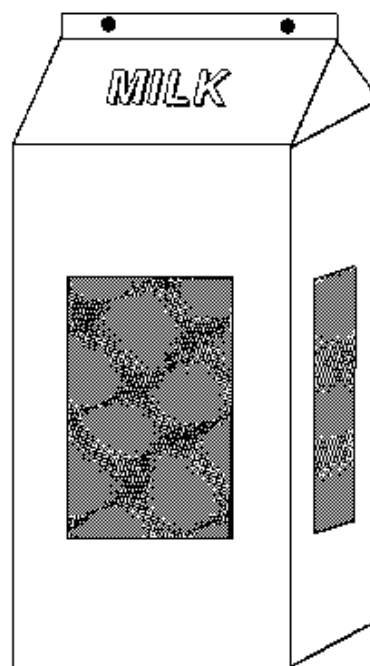

Feeder B

Large Self-Feeder

Ensure all necessary parts and tools are present. (Refer to [Figure 1](#) and hardware list below.)

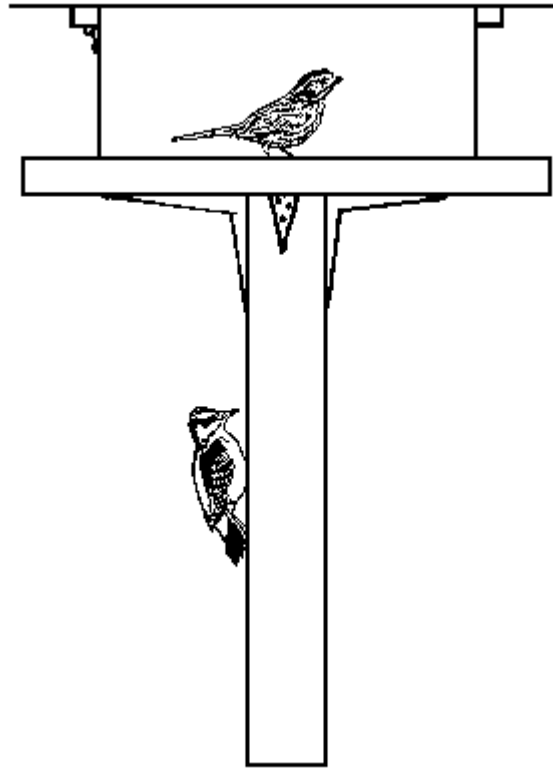

- 2 long brackets
- 2 short brackets
- 12 - 1" x 3/16" bolt/washer/nut assembly
- 2 - 3" hinges
- 2 latch hook assembly
- 48 - 1 5/8" galvanized drywall screws
- 34 - 1" galvanized drywall screws

Attach two roof stops to bottom of roof using three 1" screws per roof stop. Screws should be driven from top of roof (refer to [Figure 3A](#)).

Attach two side rails to two end rails forming a rectangle of 1 by 2s. 1 5/8" screws should be driven into side rails which overlap the end rails. Attach this rectangle of 1 by 2s to plywood floor with 1 5/8" screws driven in from plywood side (see [Figure 3B](#)). This railing will hold seed on the platform.

Assemble body of feeder utilizing two 2 x 12 x 12 1/2" ends and two 12 x 26" sides. Attach 12" plywood sides to the longer (12 1/2") length of the end pieces with four 1" screws. The 1/2" gap remaining at the bottom of the rectangular box will function to release seeds from the body of the feeder (refer to [Figure 3C](#)).

Center body of feeder on top of floor and attach from bottom of floor with 1 5/8" screws. Screws should come up through plywood and into the 2 x 12" ends.

Drill at least six 1/4" drain holes into floor of feeder platform.

Place roof assembly on the ground with roof stops facing upward. Turn body of floor assembly upside down, grasp the floor, and insert body of feeder between roof stops. (Body of feeder should fit snugly between roof stops.) Attach two hinges to one roof stop and two latch hooks to other roof stop. Attach hinges and latch hooks to body of feeder. Use 1" screws to attach hinges (refer to [Figure 3D](#)).

With roof latched and top of roof on the ground, center 4 x 4 post on bottom of floor and mark with pencil. Position brackets using pencil outline of 4 x 4 post. Mark and drill bracket holes through plywood and attach brackets with 1" x 3/16" bolts, tighten. Place 4 x 4 post into position and fasten using 15/8 screws. (Disregard this step if you plan to move the feeder to its final location in two pieces.)

Optional: Add a center peak structure as illustrated by the dashed line in Figure 3E. Two pieces of either 1/2" plywood or pine should be cut 26" long and approximately 5" wide. Nail or screw together to form a 45 degree angle and fasten to the center of the floor of the feeder body. (This structure prevents old seed from accumulating in the center of the seed reservoir and increases efficiency of seed dispersal.)

To erect feeder, dig a hole approximately two feet deep. Place post in hole and keep straight while occasionally packing dirt as hole is filled. **IMPORTANT NOTE:** Feeders must be coated with a good exterior paint for long life and weather proofing. This may be done before or after putting the feeder up. However, the portion of the post being buried should be painted unless lumber is pre-treated.

Additional: [Figure 2](#) demonstrates how to get the necessary plywood pieces to construct two large winter bird feeders from one sheet of plywood. (The cost of approximately \$9 per feeder for plywood and a \$6 charge per 4 x 4 post demonstrates that the material to build this feeder can be purchased for under \$25.)

TOOLS REQUIRED

- Table saw
- Philips head screwdriver
- Wrench to tighten bolt assemblies
- Standard screwdriver
- Paint brush/paint
- Post hole digger

Figure 1. Wood required to assemble one Large Winter Bird Feeder

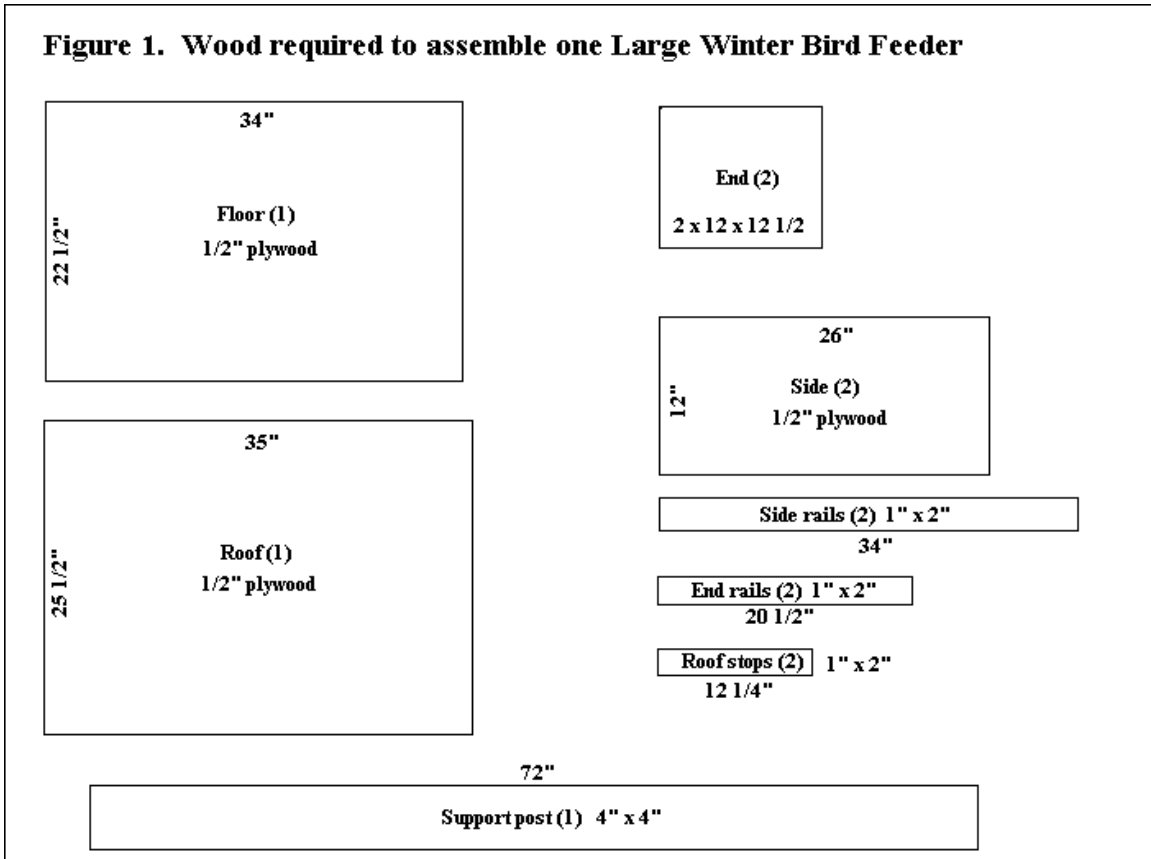

**Figure 2. Utilization of one 4' x 8' x 1/2" CDX PLYWOOD
to make two Large Winter Bird Feeders**

12"	26" (Side)	25 1/2"	35"	35"
	26" (Side)		(Roof)	(Roof)
12"	26" (Side)	Save! 22 1/2"	34"	34"
	26" (Side)		(Floor)	(Floor)

FIGURE 3. Construction diagrams

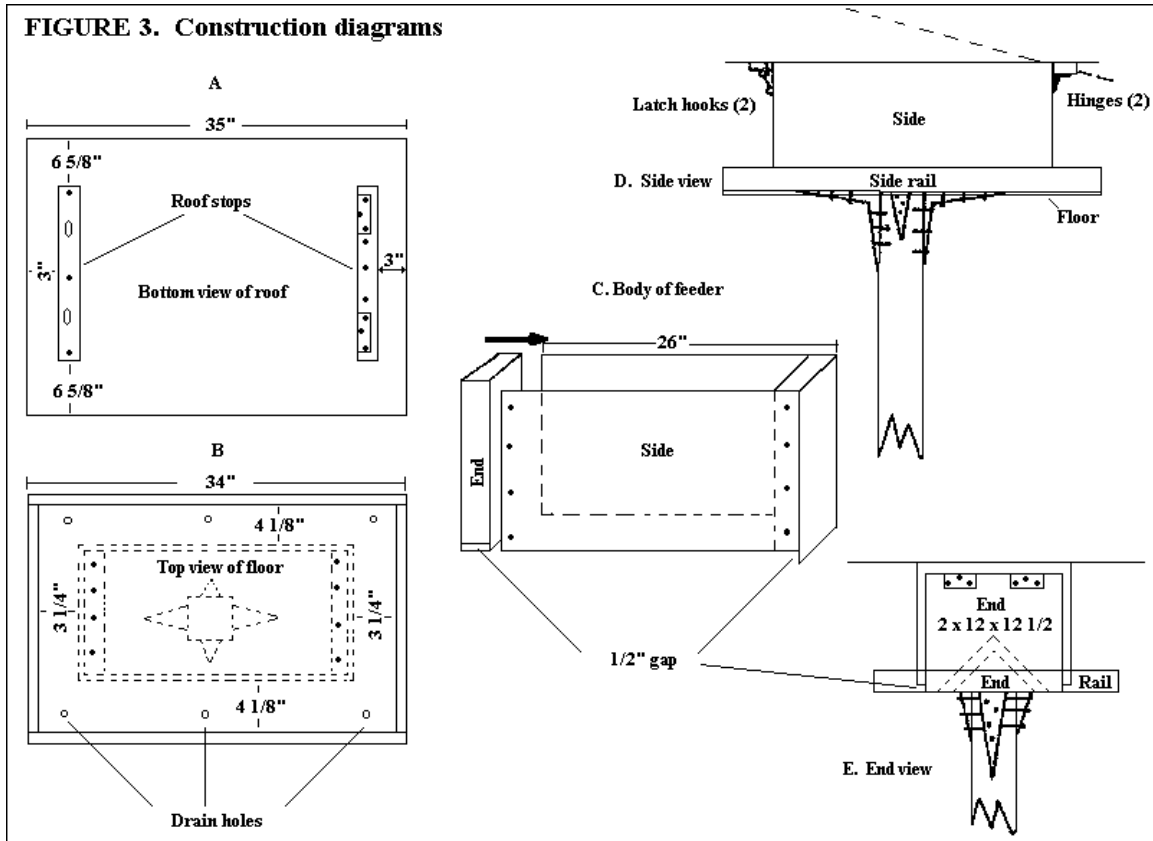

Linda Tray Feeder

Materials: 1" x 6" - 39 1/2"

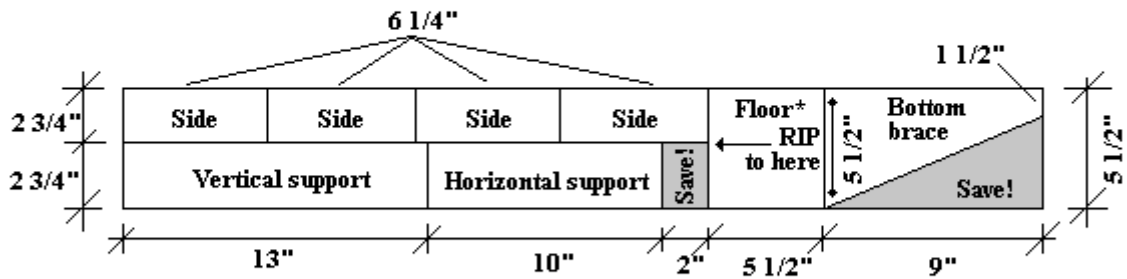
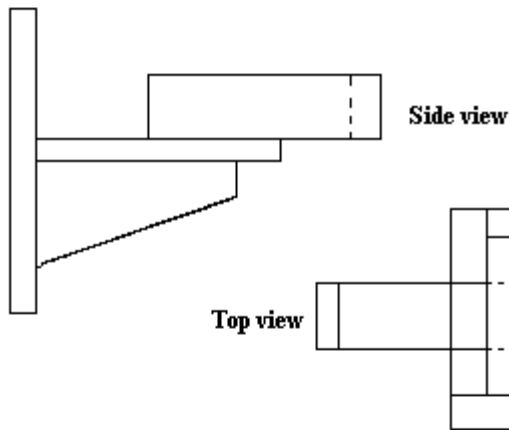
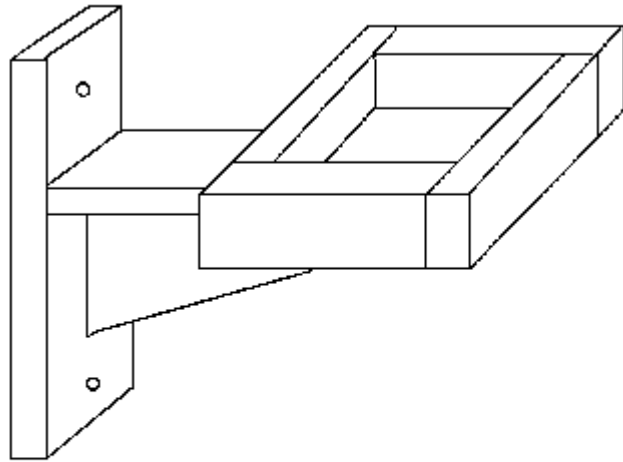

*If the board is 3/4" thick, the floor must be 5 1/2" x 5 1/2".
 If the board is 7/8" thick, the floor must be 5 1/4" x 5 1/4".

Hardware Cloth Suet Feeder

Materials:

- 11" x 10" hardware cloth (1/2" x 1/2" mesh)
- 1" x 8" - 32" (allow 1" for saw kerfs)
- 9 1/4" dowel, 7/8" diameter
- 21" nylon or poly cord, 1/4" thick

7/16" hole allows roof to slip upward on cord

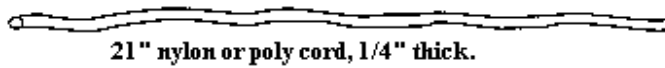
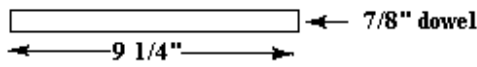
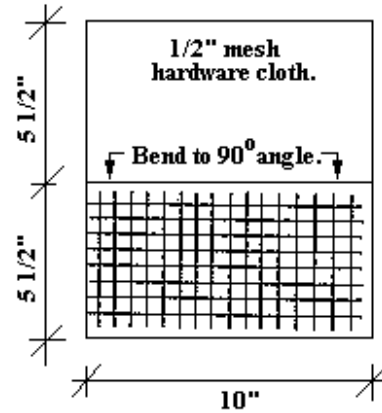
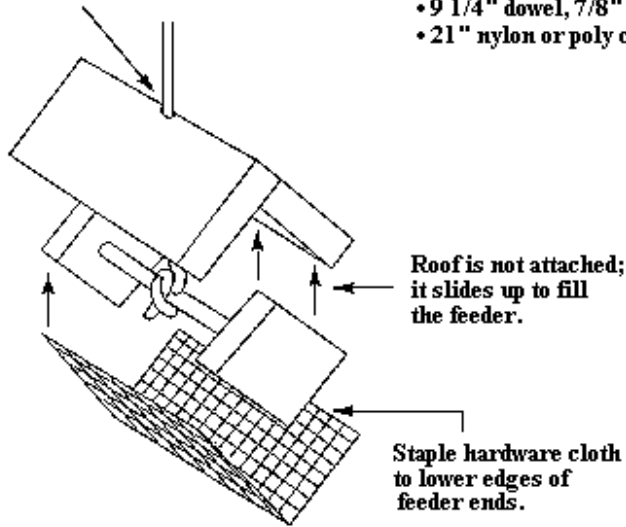

7/8" diameter hole, 3/8" deep.

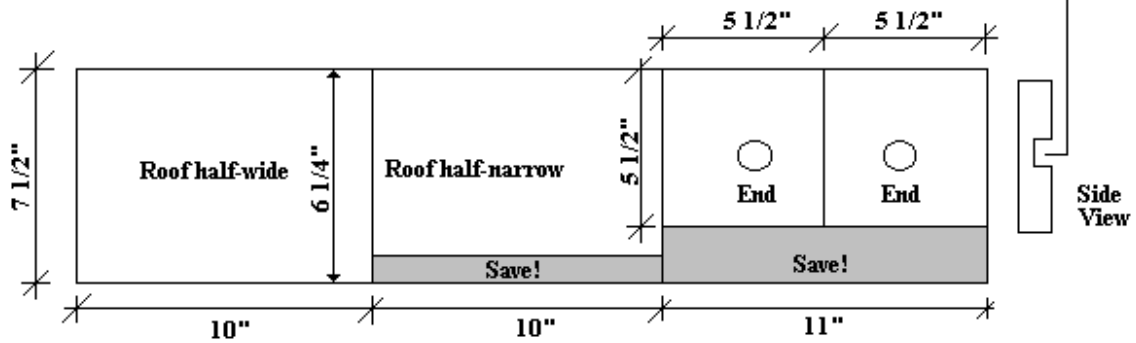

Dowel Suet Feeder

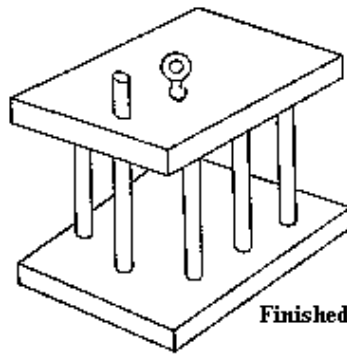

Finished dowel suet feeder.

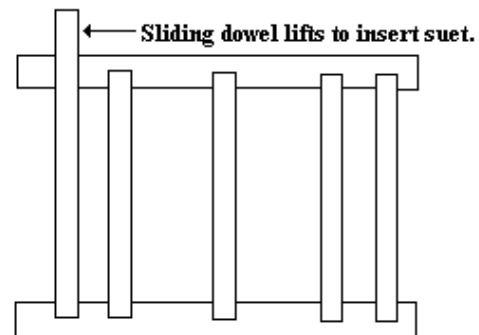
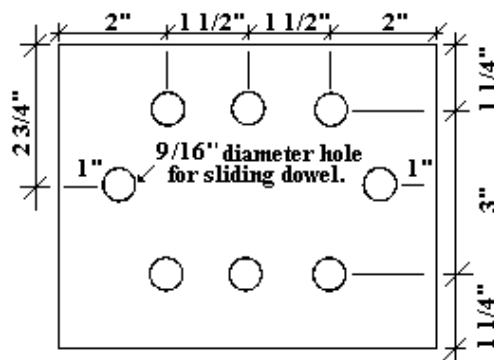

This diagram shows placement of dowel holes on the top and bottom pieces. Holes are 1/2" diameter and 1/2" deep, except that the floor hole for the sliding dowel is 1/2" deep, but the sliding dowel penetrates the roof and is lifted to insert suet.

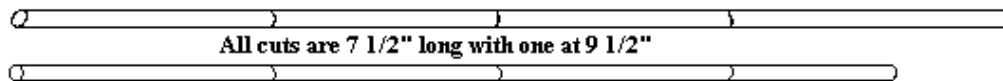

1/2" diameter dowels.

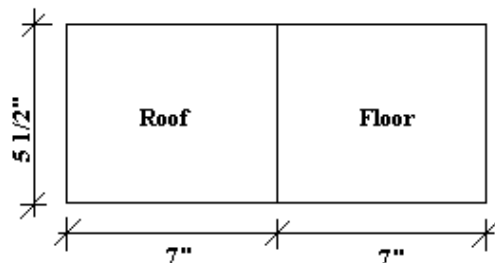

Materials:

- wood glue
- 1" x 6" - 14"
- 2 - 1/2" x 36" dowels
- eye screw (3/4" long)

Barrel Feeder for Wildlife

A simple feeder can be constructed from a 55 or 30 gallon steel barrel which can often be acquired for little or no cost. This type of feeder can be filled with any grain including black oil sunflower, corn, oats, or a mixture of grains. It serves as a ground feeder and is excellent for deer, turkeys, and other upland birds.



Instructions

Find a barrel which did not contain pesticides or other toxic chemicals. The barrels most commonly available are those which contained petroleum products. Ensure any residue is washed from the inside of such barrels.

Remove one end of the barrel. This will become the top end into which grain is poured. **Do not** attempt cutting out the end with a cutting torch as vapors within the barrel may be explosive. Instead, use a saber saw with a metal cutting blade or a large hammer and metal cutting chisel.

Make a 12 inch cut lengthwise along the bottom edge of the barrel about 2 inches above the bottom base ring. The cut should be started by first drilling a 3/8 inch hole where the cut will begin. Cut 12 inches across the bottom beginning at the 3/8 inch hole with a saber saw and fine metal cutting blade.

Pound in the metal above the 12 inch cut. The result should be a half-moon shaped opening that will release grain as it is taken from the small tray opening below.

If the barrel did not come with a lid, cut a section of exterior plywood slightly larger than the opening in the top of the barrel. Secure this lid to the barrel using tarp straps. Eye bolts can be fastened to both the barrel and the plywood for points to hook the straps. As an alternate and more simple method, nail three small blocks of wood on the bottom side of the lid just inside the top edge of the barrel and place a brick or other heavy object on top to hold the lid in place.

Predator Guards

"Predator proofing" is an important aspect to consider during the construction phase of bird nest boxes or feeders. This simple step can prevent unwanted predators from destroying eggs or young in a nest box and make your feeder more attractive for wary birds.

All of the predator guards shown below serve the same purpose--to keep predators such as house cats, raccoons, and snakes from scaling the support post to your nest box or feeder. Wood posts are the easiest for predators to climb because they provide a rough surface with a good grip. Metal pipes or posts are less likely to be climbed successfully.

Materials to build predator guards can be made from tin, sheet metal, aluminum, or heavy plastic. A good source of cheap sheeting is often a newspaper office. Aluminum sheets are used to make the impression to print the newspaper and are recycled afterwards.

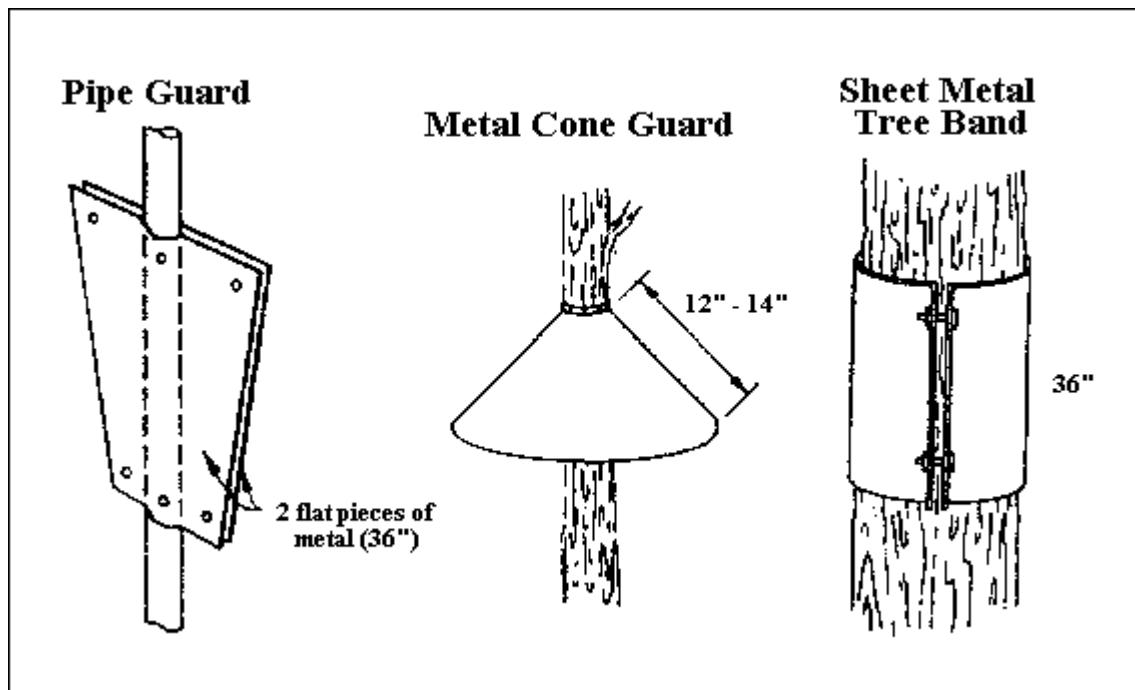

Wildlife Viewing and Photography Blinds

Viewing or photographing wildlife is made easier if you are stationary and let the wildlife come to you. It is easy to attest to that if you've ever fed birds in your back yard at a feeding station. The same approach should be used if you travel out-of-doors to view or photograph wildlife. The fact is that wildlife subjects are just that--wild, and normally won't allow you to approach closely. A little more time will be required to construct, place, and maintain a blind, but the time involved will be far less than the time spent in frustrating pursuit of wary wildlife.

There are as many types and shapes of blinds as there are inventive minds who build them. The main point is that the blind be large enough to make you comfortable, made of dark canvas so light cannot penetrate, and allow your shadow to be seen, made sturdy and anchored to the ground to prevent it from blowing away, and placed in the correct habitat and camouflaged to maximize your chances of seeing wildlife.

Choosing the correct habitat to place the blind is easier and more effective if you know your subjects' habitat and characteristics. Viewing deer, for instance, would require that a blind is placed near a food source where the deer is feeding in the evening, or on a trail that leads from where it feeds to a bedding area where it rests during the day. Another possibility would be a blind near a trail of rubbed trees where a buck frequents in the fall or an area where deer congregate to winter. Every species of wildlife act relatively the same from day to day or season to season and a pattern can usually be established if you do your research.

Other useful tips that may enhance your success include pre-positioning a blind for some time before you plan to use it. Time for the wildlife to get used to the presence of the blind is important. The blind should also be positioned so that the prevailing winds blow from the subject to your blind and not toward the wildlife. Birds are not of concern with this issue. Movement within the blind should be minimal and loud talking prohibited. Bringing a stool or short chair will make the stay more comfortable as patience is often a virtue when sitting in a blind.

Low-Profile A-Frame Blind

Materials Required:

- 4 - 6 (2x2)
- 4 - 2 1/2' (2x2)
- 4 small screws
- 3' of small chain
- 3 - hinges 2" x 3" (with screws)
- Staple gun and 5/8" staples
- 10' x 5' dark canvas
- Carpet knife
- 8 - 2 1/2" wood screws
- Wood glue (optional)

Cut 2x2 material into four 6' lengths and four 2 1/2' lengths. Miter each end with a 45° cut.

Put together with wood screws and glue (for added strength) two rectangular halves each the same size. Let dry.

Add 3 hinges along top edge of blind so halves will fold together like a closed book.

Use a second person to hold halves open to the desired height you wish blind to maintain during use. (The desired angle would likely be close to 90 degrees.) Pick a point half way between the top and bottom of the blind. Use small screws to attach a length of chain to keep blind open in desired position.

Staple canvas to frame. Make sure if canvas is attached while blind is completely open that enough slack material is left to enable folding blind back together.

The canvas at end of the blind can be left loose or tightened by cutting out extra material and stapling to one side.

Cut camera hole in one end only large enough for camera lens to fit through.

Note: This blind is an inexpensive method of gaining concealment for taking wildlife photographs. Since you must lay flat, it is not the best choice for marshy areas where water covering the ground may be a factor. A dense foam sleeping mattress may be helpful to keep you off the ground. A sandbag or beanbag works well to steady your camera or lens. A tall person may need to start with 7' or 7 1/2' 2x2 lengths.

Low - Profile A-Frame Blind

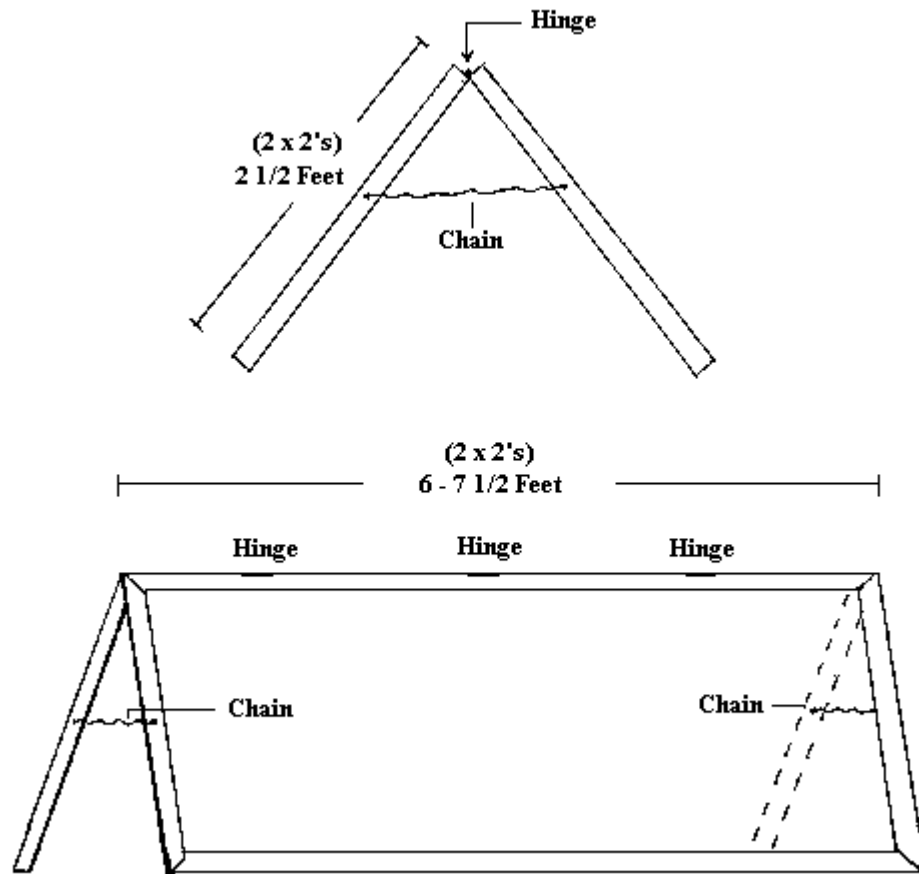

Modified Portable Fishhouse-Type Blind

This blind is fashioned after the typical portable ice house. Finding someone who owns one may give you a head start before construction.

Materials Needed:

- 2 - 4' 1 1/4" (1" x 2")
- 2 - 4' (2" x 4")
- 2 - 5' (2" x 4")
- 2 - (4' x 4') 3/8" plywood
- 7' x 14' dark canvas
- Drill and 1/16" bit, 3/8" bit
- 8' piano hinge
- Jig saw
- 1 box small wood screws (1/2")
- 1 box medium wood screws (3/4")
- Staple gun with 1/2" staples
- Carpet knife
- 8 - 3" wood screws
- Wood glue
- 8 - 4' lengths of 2" x 1/4" lathe

Cut two 4' 2x4s and two 5' 2x4s. Miter ends 90 degrees.

Make base of blind with above 2x4s by joining mitered ends together. Glue and join together with 3" wood screws.

Use piano hinge on inside edge of blind. Attach to each 4' 2x4 one 4x4 sheet of 3/8" plywood. Use 1/2" screws in plywood and 3/4" screws in 2x4. Both plywood pieces should be free to fold toward center of blind.

Begin attaching canvas on one 5' 2x4. Drill pilot holes in lathe material with 1/16" bit. Double canvas over and place lathe material over canvas. Sink 3/4" screws through lathe, canvas, and into 2x4. Have assistant hold both plywood sides straight up.

Stretch canvas over entire blind and repeat above process on opposite 5' 2x4. Cutting of some excess canvas may be necessary.

Secure 1x2s inside blind wedging them between plywood walls. These will be the supports that keep your blind from collapsing. For right now, you may wish to nail them temporarily for ease of working.

Attach canvas on plywood by using lathe and 1/2" screws. Remember doubling canvas and drilling pilot holes. Extra canvas will need to be trimmed. Use your own best judgment, however, canvas should overlap wood by at least 3".

Sit in blind with desired stool to determine level you will be photographing. At this level, trace a hole (with coffee can, etc.) slightly larger than your camera lens. Drill hole with 3/8" bit for a spot to start cutting. You may wish to have camera holes in the canvas also. Make flaps to cover holes by using excess canvas. Use velcro to attach flaps to cover unused windows.

Note: This blind is ideal for situations where water is present since the bottom is entirely open. Wear your rubber boots or use a false floor made of a pallet, etc.

