

JSC-63743

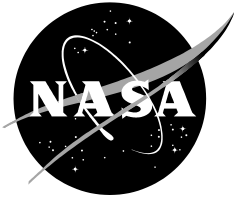

Preliminary Assessment of Artificial Gravity Impacts to Deep-Space Vehicle Design

*B. Kent Joosten
National Aeronautics and Space Administration
Lyndon B. Johnson Space Center
Houston, Texas 77058*

This page intentionally left blank

Foreword

The material contained in this report was compiled to capture the work performed by the National Aeronautics and Space Administration's (NASA's) Exploration Analysis and Integration Office in the late 2002 timeframe. The "Preliminary Assessment of Artificial Gravity Impacts to Deep-Space Vehicle Design" documents the analyses and findings this study.

During the summer of 2002, the NASA Chief Architect and the NASA Exploration Team (NExT) requested that a study be performed with the following objectives:

- Develop an understanding of the implications of artificial gravity in the design of human deep-space exploration vehicles
- Develop an example implementation utilizing nuclear electric propulsion (NEP) technology
- Develop a design reference mission incorporating a human Mars mission

The study was commissioned to help understand alternatives to potentially lengthy and expensive certification of flight crews to multi-month exposure to microgravity environments. The analysis team divided this task into several areas: trajectory analysis, performed jointly by groups at the Johnson Space Center (JSC) and the Glenn Research Center (GRC); vehicle dynamics analysis, performed by JSC's Aerosciences and Flight Mechanics Division; structural analysis, performed by Able Engineering, Inc. under contract to JSC; power and propulsion analysis and habitation systems analysis, both performed by teams at JSC. Particular emphasis was given to understanding performance penalties associated with incorporating artificial gravity into spacecraft designs. Results from this study produced a unique approach to vehicle steering and attitude control without massive, despun vehicle components or excessive propellant consumption. Very little (~5%) additional structural or propellant mass was identified above that required for zero-gravity transfer. There were several issues that were identified for potential follow-on studies: crew ingress/egress and transfer options, designs for external pointed devices such as antennae and star trackers; vehicle assembly and transfer to departure orbit; and trades involving planetary parking orbits.

This page intentionally left blank

Table of Contents

Introduction	1
Objectives	1
Ground Rules	1
Artificial Gravity Parameters	1
Mission Archetype	3
Previous Studies	4
Approach	5
Study Results to Date	7
Trajectory Analysis	7
Dynamics	8
Structures	13
Power and Propulsion	15
Habitation	17
Structures	17
Thermal Control System	18
Environmental Control and Life Support System	19
Human Factors and Habitability	20
Systems Issues	21
Architectural Issues	22
Conclusions	22
Future Work	23
References	24
Attachments	25

This page intentionally left blank

Preliminary Assessment of Artificial Gravity Impacts to Deep-Space Vehicle Design

Introduction

Even after more than thirty years of scientific investigation, serious concerns regarding human physiological effects of long-duration microgravity exposure remain. These include loss of bone mineral density, skeletal muscle atrophy, and orthostatic hypertension, among others. In particular, Ref. 1 states

“...loss of bone density, which apparently occurs at a rate of 1% per month in microgravity, is relatively manageable on the short-duration missions of the space shuttle, but it becomes problematic on the ISS [International Space Station]... If this loss is not mitigated, interplanetary missions will be impossible.”

While extensive investigations into potential countermeasures are planned on the ISS, the delay in attaining full crew complement and onboard facilities, and the potential for extending crews' tours of duty threaten the timely (< 20 years!) accumulation of sufficient data for countermeasures formulation. Indeed, there is no guarantee that even with the data, a practical or sufficiently robust set of countermeasures will be forthcoming.

Providing an artificial gravity (AG) environment by crew centrifugation aboard deep-space human exploration vehicles, long a staple technique of science fiction, has received surprisingly limited engineering assessment. This is most likely due to a number of factors: the lack of definitive design requirements, especially acceptable artificial gravity levels and rotation rates, the perception of high vehicle mass and performance penalties, the incompatibility of resulting vehicle configurations with space propulsion options (i.e., aerocapture), the perception of complications associated with de-spun components such as antennae and photovoltaic arrays, and the expectation of effective crew micro-gravity countermeasures. These perception and concerns may have been overstated, or may be acceptable alternatives to countermeasures of limited efficacy.

Objectives

This study was undertaken as an initial step to try to understand the implications of and potential solutions to incorporating artificial gravity in the design of human deep-space exploration vehicles. Of prime interest will be the mass penalties incurred by incorporating AG, along with any mission performance degradation.

Ground Rules

Artificial Gravity Parameters

In order to establish design requirements and constraints for an artificial gravity spacecraft, past ground-based and space-based research was reviewed. The parameters gravity-level (a_{AG}) and rotation rate (ω) are crucial to the

feasibility of AG spacecraft designs, since they determine the required rotational radius: $a_{AG} = \omega^2 r$.

It must be noted that *there is essentially no data*, either through experiments or analyses to give any indication of the effectiveness of partial-gravity in ameliorating the physiological effects of microgravity. Additionally, such experimental data would be exceedingly difficult, time-consuming, and expensive to gather from human test subjects, requiring something like a space-based, variable-gravity rotating facility. For these reasons, *this study assumed an AG level of 1-g was required*.

Similarly, there is *no data* indicating that a crewmember could be centrifuged for a limited time (i.e., on a “daily” basis) in order to avoid deleterious microgravity effects. This data would be difficult to attain for the reasons stated above, and it is possible that the crewmembers would experience the stressful (and unpleasant) effect of readaptation at each cycle. Therefore, *this study assumed that the crew would be under nearly continuous centrifugation throughout the mission*.

The U.S. ground-based facilities that were capable of performing centrifugation research with human test subjects included the Pensacola Slowly Rotating Room (in operation from 1960-74) and the Rockwell Rotating Test Facility (1970). In the Soviet Union, the “MVK-1” and “Orbita” facilities served similar purposes. These facilities allowed test subjects to be centrifuged at varying rotational rates for weeks at a time, permitting assessment of motor skills, adaptation, and physiological effects. The main concerns involve the “cross-product” or “coriolis” accelerations experienced while an object is moving relative to the rotating environment. For humans, this manifests itself as accelerations sensed by the vestibular system (due to, for example, head movements) without corresponding visual cues, resulting in symptoms akin to motion sickness. The subjects experienced total (vector sum of induced and terrestrial) gravity levels of 1 to 1.4 g’s. The results of these studies are summarized:

“...at a speed of 4 rpm, some individuals will be naturally immune to motion sickness while others will have motion sickness but will adapt after a few days and suffer little decline in performance.” (Ref 2)

When rotation ranges from 3 to 6 rev/min ... the initiation of rotation will elicit changes in postural equilibrium as well as symptoms of motion sickness, the extents of which are a function of the magnitude of the angular velocity. Nevertheless, adaptation can be achieved under these conditions in 6 to 8 days, and the remainder of the stay in the rotating environment is characterized by normal health and performance.” (Ref. 3)

“...ground-based results can be extrapolated to the spaceflight environment only when the AG in that environment is equivalent to 1 g.” (Ref. 3)

Based on these conclusions, *this study baselined a maximum rotational rate of 4 rpm*. The impact of this assumption on spacecraft design practicality should be stressed. At 4 rpm, an AG level of 1-g is achieved with a rotational radius

of 56 meters. If the acceptable rate were, for example, only 1 rpm, the required radius would be ½ mile!

Finally, there were several space-based experiments that indicated the efficacy of artificial gravity. The Soviet Kosmos 782 (1975, 19 day flight) and Kosmos 936 (1977, 18 day flight) flew a facility in which ants, turtles, rats, plants, and cell and tissue cultures were centrifuged at 1-g, along with a 0-g control group. Postflight examination indicated the “artificial-gravity groups showed no evidence of typical adverse effects of microgravity” (Ref. 2). Also, in 1985 the Shuttle/Spacelab D-1 mission flew a biorack centrifuge containing seeds, bacteria, and human blood cells. These results were summarized: “microgravity effects at the cellular level may be eliminated by artificial gravity” (Ref. 2). *This study assumed that a centripetal acceleration of 1-g would be physiologically equivalent to a gravitational acceleration of 1-g (excluding coriolis effects).*

Mission Archetype

To evaluate a conceptual spacecraft design, some sort of mission parameters must be established to allow systems trades such as propulsion, power, habitation, etc. and establish the impact of an artificial gravity configuration. It was the intent of this study to retain a certain level of mission-independence, allowing the results to be applied to a range of destinations and mission classes. In reality, the combination of attainable propulsion technologies and potential destination distances which equate to flight times requiring artificial-gravity led naturally to round-trip Mars missions as a mission “archetype”.

More specifically, this study adopted a Mars “opposition-class” mission, typified by an 18-24 month round trip with up to three months spent in the Mars system. This trajectory class can stress the interplanetary “steering” requirements, which may be a concern for rotating spacecraft. Also, these types of missions are challenging from the standpoint of propulsive performance, and it is desired to establish compatibility between AG and advanced propulsion technologies. In addition, a “split” mission approach was chosen, meaning that the crew transfer spacecraft does not bear the burden of transporting elements such as planetary landers, surface habitats, etc., which are assumed to be delivered by separate means, presumably on lower-energy trajectories. This allows some freedom in the spacecraft configuration, avoiding constraints imposed by less defined mission goals.

Previous design studies treated artificial gravity as a design requirement that was often dependent upon other parameters, specifically, propulsion technologies. Often times, an AG option was “tacked on” to propulsion choices made *a priori*, with questionable compatibility. In this study, AG was considered the driving requirement, with other system choices made (within “technology horizon” constraints) to be most compatible. One of these was nuclear electric propulsion (NEP).

NEP performance is characterized by relatively low-thrust, but high efficiency. This low thrust level should allow vehicle thrusting while under rota-

tion due to the resulting small forces and torques, obviating the spindown-burn-spinup sequences required by high thrust systems (however, techniques for continuous thrust vectoring must be established). There may be inherent vehicle configuration synergies between NEP and AG. Typically, NEP vehicle designs require long masts or trusses to separate the nuclear power source from the regions of crew habitation (this “ $1/r^2$ ” radiation shielding can be very mass-efficient, given light-weight masts). Such structures may also serve as the AG rotation “arms”. Finally, as described below, the mass of the power production and conversion systems may serve as a good “counterweight” for the crew habitation systems, allowing a highly synergistic vehicle configuration.

To avoid conclusions regarding AG feasibility being influenced by questionably optimistic propulsion technology assumptions, this study established a “technology horizon” or initial operating capability of ~2015. This helped establish some of the key NEP performance parameters, enabling initial vehicle configuration concepts.

In Mars mission studies, the departure and return orbits at Earth are typically chosen to reflect the capabilities of the selected propulsion system. The arrival/departure orbit at Mars is usually chosen to reflect trades between the propulsive characteristics of the transfer vehicle and the lander. NEP vehicles typically exhibit poor performance deep in planetary gravitational fields since the low thrust levels translate into higher gravity losses and long orbit transfer times. For this reason, these studies assumed a high departure and return orbit at earth, specifically, the Earth-Moon “ L_1 ” Lagrange point. This location may be synergistic with other human exploration goals, and as nuclear systems provide the performance capability for a reusable transfer vehicle, this staging location may be compatible with the operational characteristics of reusable space nuclear systems. Trades involving the assembly and delivery of the transfer vehicle to L_1 are not addressed in this preliminary analysis. The Mars orbit selection has been left open to trades in this study, but it was not evaluated in detail. Trajectory design of optimal low-thrust insertion into planetary orbits is a complex analysis, and will be addressed in future tasks. This study approximated the time and propellant required for transfer vehicle descent to and ascent from various circular Mars orbits.

Finally, this study assumes that a sustainable Mars exploration program is desired. As the vehicle under consideration will represent a considerable investment, and because nuclear systems have inherently high energy content, a vehicle reusability requirement of greater than three round trip missions is assumed.

Previous Studies

As stated, the number of past vehicle engineering studies designed to incorporate AG is not large. Two, however, were deemed to have requirements similar to those outlined above, and were examined for configuration concepts and operational strategies. The main differences in the two concepts centered on

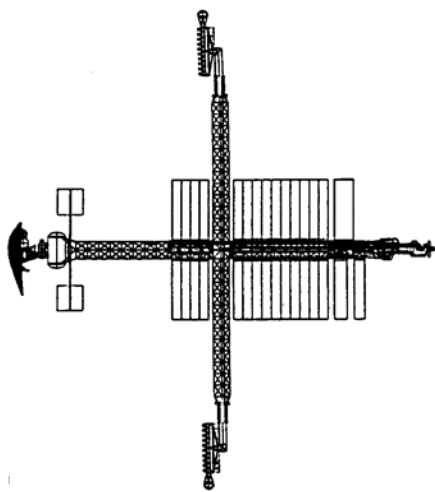

Figure 1. Ref. 4 Vehicle Configuration

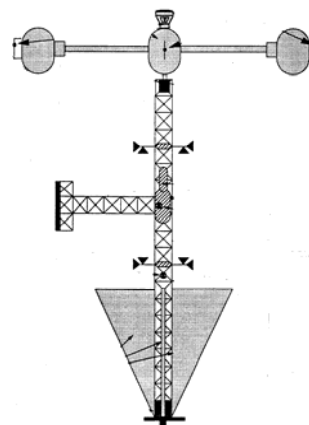

Figure 2. Ref. 5 Vehicle Configuration

the system masses used to counterweight the habitation volume during rotation. Ref. 4 (Fig. 1) utilized the mass of the nuclear power generation and conditioning systems, while Ref. 5 (Fig. 2) split the habitation volume. Both concepts feature despun propulsion systems in order to allow thrust vectoring without requiring the precession of the angular momentum associated with the rotating sections. The strategy was to align the rotation plane with the interplanetary trajectory plane, as most optimal low-thrust profiles produce planar trajectories. While this may alleviate one design issue, another presents itself. Large mechanical rotation joints are required with continuous 100 kilowatt- to megawatt-level power transmission across the interfaces. While such mechanisms are undoubtedly technically feasible, the mass, complexity and reliability of such devices may prove challenging.

Approach

This study opted to initially focus on a simpler configuration which would potentially eliminate the need for large rotating interfaces, and examine the dynamics issues involving precession of the entire rotating vehicle for thrust vector control. To accomplish this efficiently, three top-level design goals need to be met: 1) utilize the power production and conditioning systems as a counterweight to the habitation volume to avoid ballasting or inefficient splitting of the habitat, 2) operate the power systems at gravity levels of $\sim 1\text{-g}$ to simplify system qualification, and 3) achieve the propulsive performance necessary to accomplish the archetype mission with technology assumptions consistent with the “technology horizon”. The implications of these goals are: 1) the power system mass must be nearly equal to the habitation system mass, and 2) the power system can assume a specific power level (α) of 4-8 kg/kWe and the propulsion system a specific impulse (I_{sp}) of 4000-6000 sec.

Based on past NEP mission analysis data (Ref. 6,7,8), and habitation module design studies (Ref. 9) it appears that all of these design goals can be met.

Figure 3 illustrates the relationships among the parameters. The resulting vehicle power levels will lie in the range of 4-8 MWe.

The initial vehicle design is illustrated in Figure 4. The design trades that led to this configuration will be discussed in the next section.

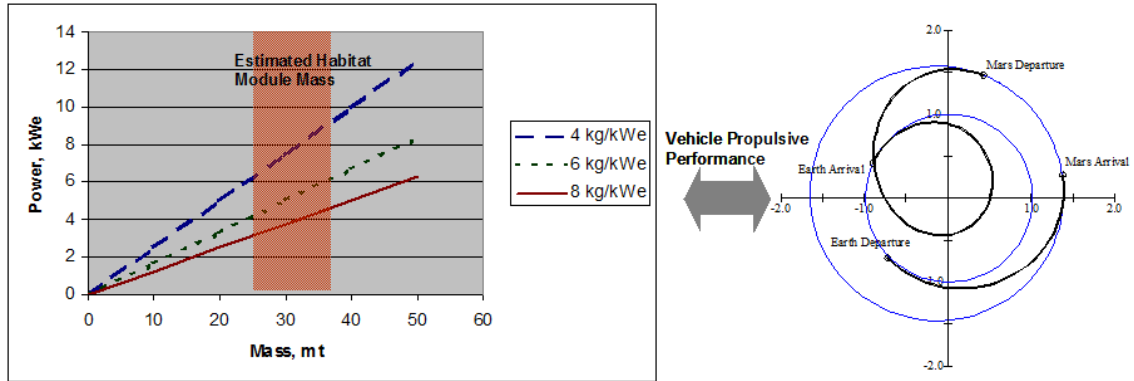

Figure 3. Design Parameter Relationships

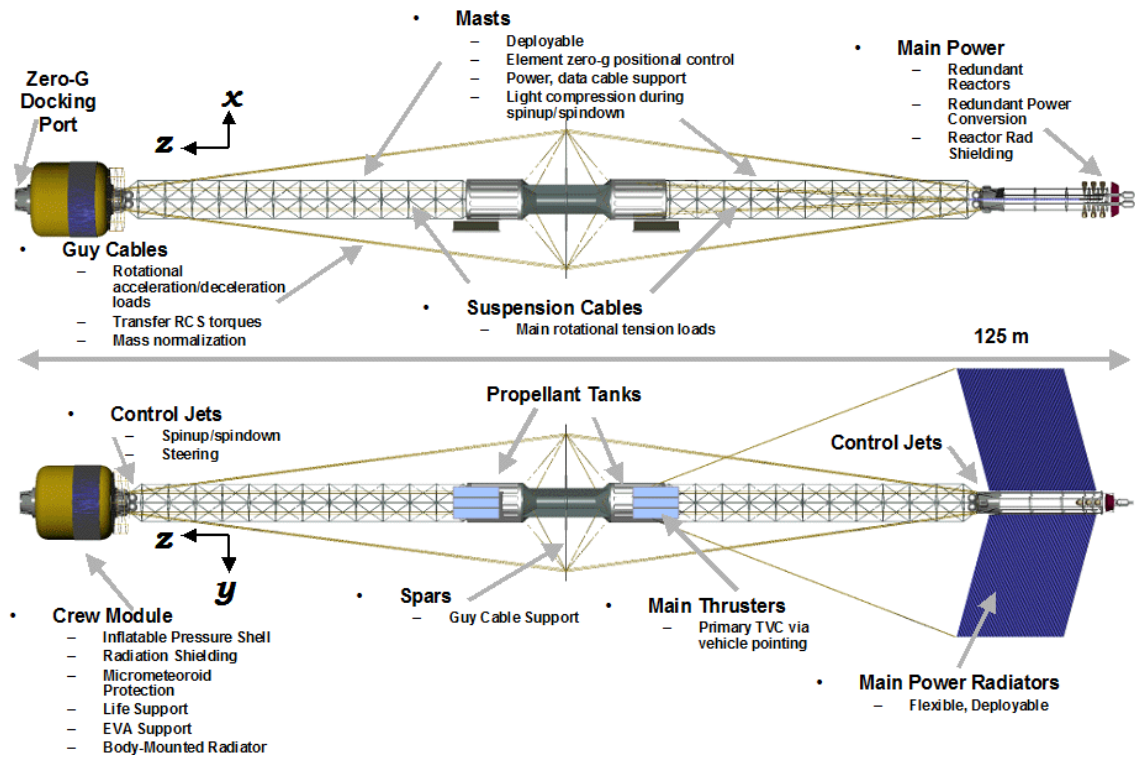

Figure 4. Initial Vehicle Design Concept

Study Results to Date

Trajectory Analysis

Because the trajectory class specified in the mission archetype displays significant variation in energy requirements over the Martian synodic period, a vehicle performance assessment was made for a representative “good” opportunity (2018) and “poor” opportunity (2026). Because low-thrust trajectory optimization is still a somewhat labor-intensive process (Isp, power level, specific power, and flight time can all be independent variables in the optimization process), three separate groups with three different analysis tools supported this activity. A group at the Johnson Space Center utilized a tool call RAPTOR, which is based on calculus of variations with a genetic algorithm to find reasonable initial control functions, the Glenn Research Center used VARITOP, also using a calculus of variations approach, and Science Application International Corp. brought CHEBYTOP to bear, a parameter optimization program based on Chebyshev polynomial approximations to the control histories. The results we compared to understand both the trajectory characteristics and any biases introduced by the individual tools.

These analyses indicated that the archetype mission can be accomplished within the power, specific impulse, and specific power ranges desired for the vehicle systems. Example mission performance results are shown in Figure 5. In each case, the stay-time at Mars was constrained to be no less than 90 days. The overall mission flight time in the “poor” opportunity was at the upper end of the desired goals. Shorter flight time may be achievable by increasing the vehicle power level, but this would imply a more technically challenging α to maintain the desired habitat counterweight. Alternatively, there may be trajectory techniques, including additional thrust arcs and Venus gravity assists on the return legs, which could increase performance.

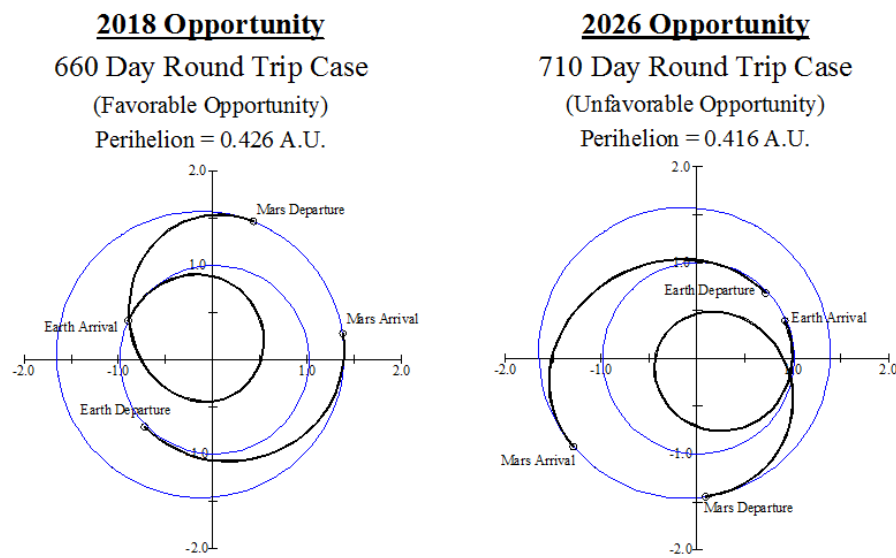

For both cases: 6MW at 6 kg/kW, 5000 sec Isp, 90 MT dry mass

Figure 5. Representative Mission Performance

The return legs of these trajectories typically result in ~0.5 A.U. perihelia. While this may sound somewhat daunting, analysis has shown the thermal control capabilities of both the habitat and power conversion systems to be acceptable. These conditions may also be somewhat alleviated by the trajectory design technique mentioned above.

Dynamics

The inherent stability of objects rotating about particular axes is determined by the ratio of the object’s principle moments of inertia as illustrated in Figure 6. The vehicle concept shown in Figure 4 is obviously a “major axis spinner”, although the near symmetry about the z-axis may result in some level of active “roll” control requirement. This symmetry, combined with the location of the propellant tanks near the axis of rotation, should minimize the vehicle’s angular momentum to the degree possible, allowing maximum maneuverability while under rotation, and minimum spinup/spindown effort.

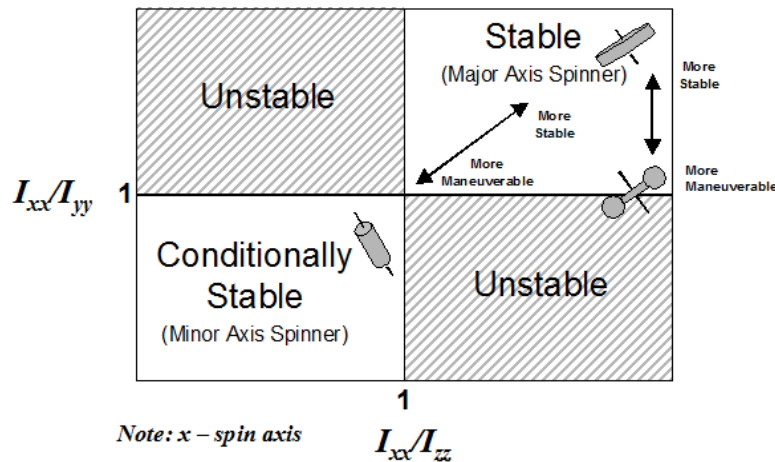

Figure 6. Rotational Stability

The vehicle spinup/spindown requirements are not particularly difficult to meet. Note from Figure 4 that the control jets are located such that they possess considerable moment arms. One trade that can be made is between spin thrust level and thruster on-time. If extended spinup times are acceptable, electric arcjets may have a role to play in this function. A thrust level of ~10 N would be adequate to establish a 4 rpm rotation rate in around two days, utilizing 100 kWe arcjets (assuming 30% jet efficiency). Abundant onboard power should be available since the main vehicle thrusters would probably not be utilized during spinup. The advantage of arcjets would be propellant reduction as illustrated in Table 1.

The primary parameter that will determine the feasibility of the vehicle configuration under consideration is the steering requirements during the mission. Recall, that to eliminate despun vehicle components and mechanical rotational interfaces, it was proposed to precess the angular momentum of the entire

Table 1. Vehicle Spinup Propellant Requirements

Thruster Isp, sec	Prop mass for spinup (or down), kg
310 (MMH/N2O4)	580
450 (LOX/LH2)	400
800 (Arcjet)	222
1000 (Advanced Arcjet)	180

Total moment = 2*Thrust*Moment arm
Moment arm = 50 m
Vehicle $I_{xx} = 2.1 \times 10^8$ kg-m²

spacecraft in order to adjust the thrust vector. The trajectory analysis indicates that the steering requirements seem to fall into two classes – very slow rates ($< 2^\circ/\text{day}$) during the majority of the heliocentric trajectory, and moderate rates ($10\text{-}15^\circ/\text{day}$) during Earth departure and arrival and during midcourse thrust reversals. This dichotomy suggests that different steering strategies may be pursued for these different mission phases. Higher rates would not be anticipated unless descent to lower Earth or Mars orbit was required.

This precessional steering would be accomplished by torquing the rotating vehicle at right angles to the desired steering direction. This torque would need to be applied intermittently during the proper phase of the vehicle rotation. Two different techniques could be utilized: 1) firing control thrusters, or 2) differentially throttling the main propulsion thrusters, as illustrated in Figure 7. The effectiveness of each of the methods will be examined.

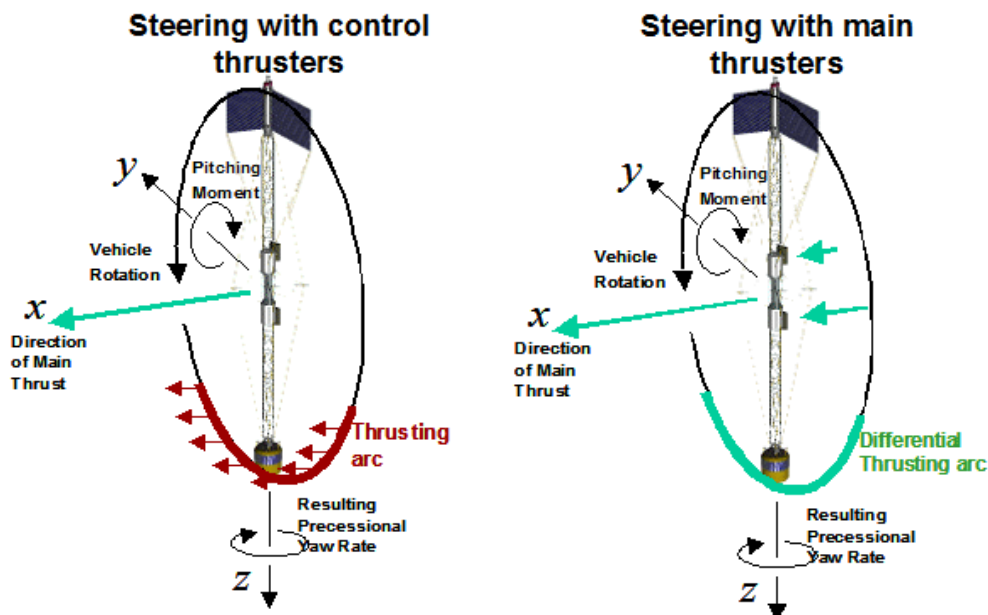

Figure 7. Precessional Steering Options

The effectiveness of control jet steering can be estimated by integrating the precession equation and substituting the control jet efficiency parameters. This indicates (not unexpectedly) that propellant quantity requirements can be relatively high, especially for chemical systems as shown in Table 2. In fact, if the steering for the entire mission was accomplished in this manner, the total requirement could exceed 15 tons (assuming 1440° of total turning). On the positive side, if the jet firings are implemented as non-coupled and always in the direction of flight, the thrust not only torques the vehicle, but also adds to its overall ΔV . This effect is shown in the last column of Table 2.

Table 2. Control Jet Steering Propellant Requirements

RCS Isp, sec	Prop. for 360° yaw, kg	Normalized for main prop. savings, kg.
310	4000	3690
450	2760	2450
800	1550	1240
1000	1240	930

$$\Delta\psi = \frac{gI_{sp}m_{prop}r}{I_{xx}\omega_S}$$

The thrust level required is a function of the required turning rate. For the moderate rates (10-15°/day), 10-15 N of thrust is required if a pulse is applied every 180° of vehicle rotation. For low rates, only 2-3 N is required. Again, arcjets may be applicable for this function, as the thrust levels, power requirements, and duty cycles are reasonable for this propulsive technology. Figure 8 shows the relationship of thrust, power requirements, and resulting turn rates.

The second steering technique uses moments generated by differentially “throttling” the main electric propulsion thrusters during powered flight. This can be accomplished by either varying the propellant flow rate to the thrusters at a constant power input, or by varying the thruster power input at a constant flow rate. Additional main propulsion analysis will be required to make a definitive selection, but in this study, the former technique was assumed. In either case, it should be kept in mind that *steering by this technique uses essentially no additional propellant.*

The steering effectiveness of this method and the amount of throttling required will be a function of thruster location on the vehicle. The farther from the spin axis they are placed, the greater the turning effectiveness. However this would result in long feed lines from centrally located propellant tanks (recall the propellant was located near the spin axis to reduce the vehicle’s moment of inertia). For this study, the thrusters were located near the tanks, with

thrust offset 10 m from the vehicle spin axis. To attain the low, interplanetary steering rates ($\sim 2^\circ/\text{day}$), a $\pm 5\%$ thrust variation every 180° of vehicle spin was required. This equates to a thrust level variation of ± 5 N per thruster produced by a propellant flow rate variation of ± 0.25 grams/sec. Figure 9 shows results of a numerical simulation of this steering technique.

The selected vehicle configuration makes one additional steering technique possible. If a nearly 180° steering change is required, the vehicle could be rotated about its minor axis (z-axis in Figure 4). This could provide a relatively rapid reverse in thrust direction, without slewing the vehicle's angular momentum. Another possible implementation of this technique could be a second set of main thrusters with a “-x” thrust direction, eliminating the need for the minor axis rotation. The applications for such a maneuver would be the mid-course “turnarounds” and limited planetary “spiral-ing”.

To formulate an example steering strategy, the mission profile was divided into segments where the three different steering techniques described above could be used to their greatest advantage. Table 3 shows that by utilizing control arcjet “impulse” steering for the moderate rate maneuvers, main thruster steering for the low rate maneuvers, and minor axis rotation for the 180° maneuvers, the steering propellant requirements can be reduced from the initial estimate of 15 tons to around 1 ton.

$$\dot{\psi} = f \frac{r T_a}{I_{xx} \omega_s}$$

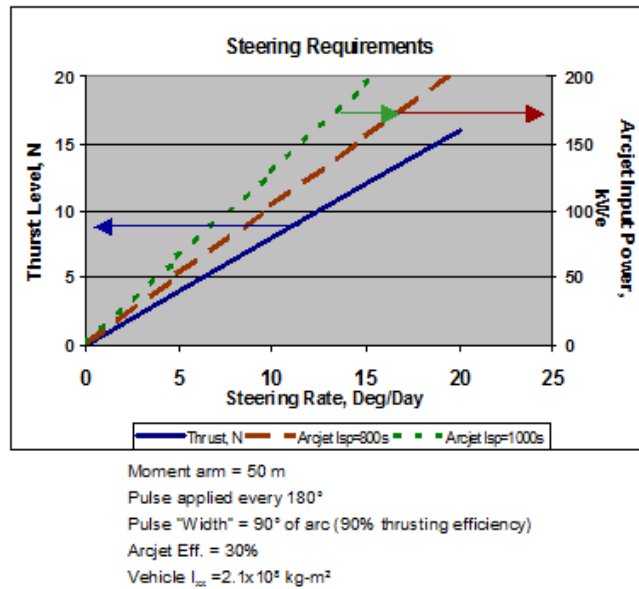

Figure 8. Control Jet Steering

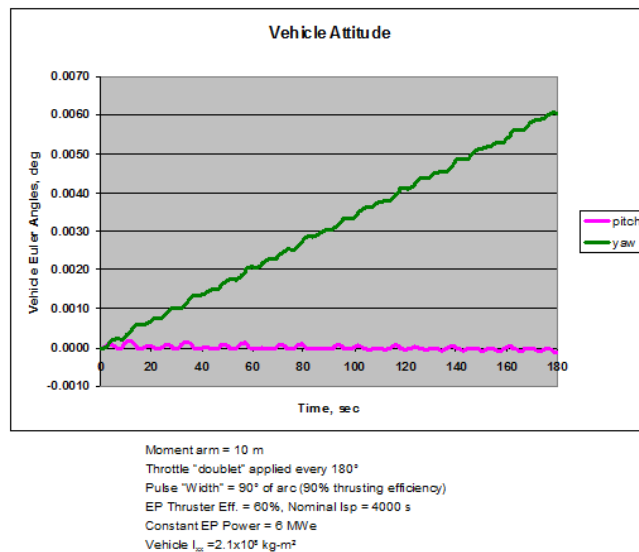

Figure 9. Main Propulsion Steering

Table 3. Steering Strategy

Mission Phase	Maximum Turn Required	Maximum Required Turning Rate	Impulse Steering Only (ArcJet)	Impulse + Minor Axis Rotation	Impulse + MAR + Main Propulsion Modulation
Earth-Moon L ₁ Departure	180°	15°/day	620 kg	620 kg	537 kg
Heliocentric Outbound, 1 st arc	65°	2°/day	224 kg	224 kg	0
Mid-Course Thrust Reversal	180°	~10°/day	620 kg	TBD (small)	TBD (small)
Heliocentric Outbound, 2 nd arc	65°	2°/day	224 kg	224 kg	0
Mars-Sun L ₁ Arrival	small	small	~0	~0	~0
Spiral to/from High Mars Orbit	Multiple revs	288°/day slew (Deimos) 180°/hr MAR	Impractical	TBD (small)	TBD (small)
Mars-Sun L ₁ Departure	180°	2°/day	620 kg	TBD (small)	~0
Heliocentric Inbound, 1 st arc	225°	2°/day	775 kg	775 kg	0
Mid-Course Thrust Reversal	180°	~10°/day	620 kg	TBD (small)	TBD (small)
Heliocentric Inbound, 2 nd arc	225°	2°/day	775 kg	775 kg	0
Earth-Moon L ₁ Arrival	180°	15°/day	620 kg	620 kg	537 kg
			5098 kg	3238 kg	1074 kg

Structures

It is evident that spacecraft extended structures of some type will be necessary for the 1-g, 4 rpm AG operation. These structures must be lightweight to maintain propulsive performance, must be somewhat stiff and strong to support the centripetal tension loads and to transfer propulsion forces and moments, and must be deployable or extendable for practical assembly scenarios.

Initially, a “suspension-compression” structure was proposed using cables for counterweight mass support during spin, guy cables and spars for moment transfer from the outboard control jets, and an erectable mast for positional control of vehicle modules (no spin) and compression loading during the initial stages of spinup and final stages of spindown. The material selected for the cabling was liquid crystal polymer fibers due to their large specific tensile strength (16x steel) and their high resistance to abrasion, fatigue and radiation. For the masts and spars, ultra-high modulus graphite was selected for its extreme stiffness, large compressive strength and negligible thermal expansion. This was the concept shown in Figure 4.

The design for the main masts became somewhat problematic. These structures will only be transiently loaded in compression (on the order of 20 N at initiation of spinup). For AG operations, it serves no structural purpose, and matching the strain of the suspension cables with the zero-load mast length may result in complex positional mechanisms. A deployable, articulated mast also would not be appropriate for tension loading of the magnitude required by the AG vehicle if it were to replace the suspension cables, as the joints connecting the segmented longerons and diagonals would be prohibitively large and massive.

A different approach was investigated. A “coilable” mast design using continuous pultruded uniaxial composite longerons is proposed. Such a design resembles a “rope ladder/tether” type structure in that it is not sized based on buckling strength, but rather by axial load capability. An important distinction

is that such a structure can also resist bending and shearing loads. The graphite-epoxy fibers would be continuous along the length of the longeron and oriented optimally for axial stiffness. There are no joints along the mast to in-

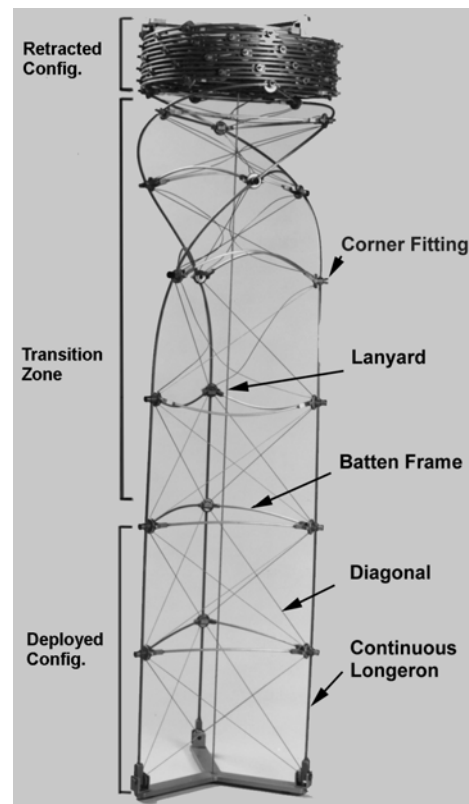

Figure 10. Coilable Mast Concept

duce compression/tension hysteresis or failure modes, and there is essentially no “non-structural” material. An example of such a structure is shown in Figure 10.

The study contracted with Able Engineering to design such a structure which could support the tension loading of the vehicle AG operation, and could also transmit the forces and moment associated with the main propulsion system and the steering strategies identified above. An extremely lightweight (150 kg), compact (<1 m stowed length for a 50 m mast) design resulted. To reduce the strain energy of the packaged boom, the design uses a bundle of small-diameter rods instead of a single large rod for each longeron. This also provides structural redundancy and reduces the mast deployment push forces. This intrinsic push force is sufficient for deployment, with a motorized lanyard to pay out the masts (Figures 11 and 12). The Able report is included as an attachment.

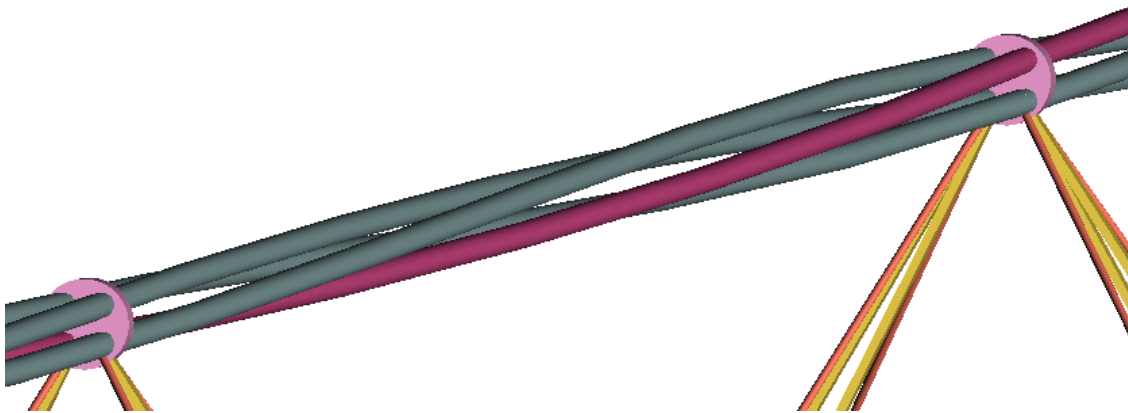

Figure 11. Longeron Bundle

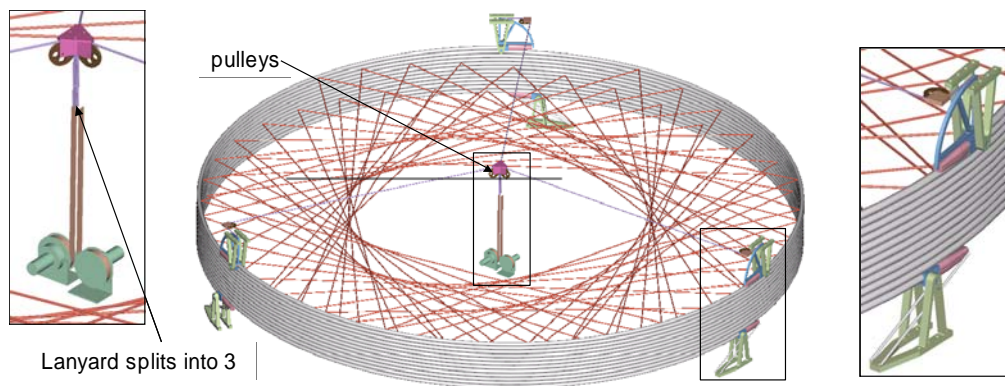

Figure 12. Stowed Mast and Deployment Mechanisms

Power and Propulsion

Three power and propulsion point scenarios were examined to understand the effects of reactor power, power conversion, and propulsion efficiency on the wet mass of the AG transfer vehicle. In addition, reductions in habitat and vehicle structural masses were assessed. All of the scenarios were able to accomplish the archetype mission. The results are shown in Figure 13. It should be noted that modest changes in these parameters can have the effect of halving the vehicle wet mass. For this study, the most conservative scenario (Scenario 1) was assumed, but this sensitivity indicates that future work should carefully examine the expected level of performance of these systems.

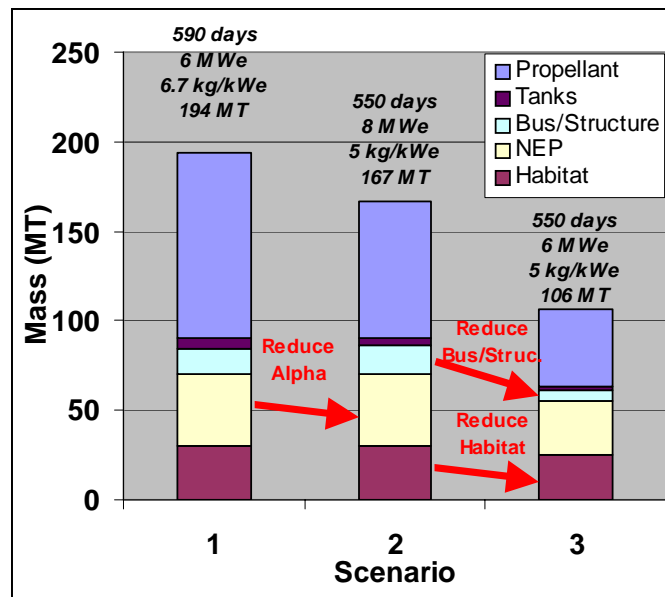
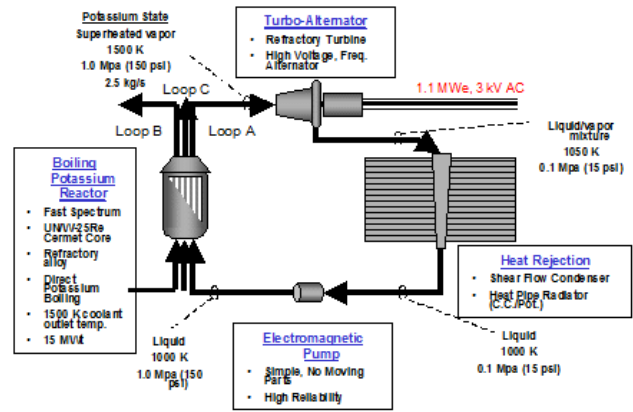

Figure 13. Power/Propulsion Scenarios

The reactor design used for assessment purposes was a 15 megawatt-thermal fast spectrum, boiling potassium reactor with a ceramic/metal core composed of uranium nitride in a tungsten/rhenium matrix (UN/W-25Re). The power system would utilize two such reactors, having a four-year life at full power operation. A potassium-Rankine power conversion system was chosen over other cycles, as this would result in lowest power conversion system mass at these power levels, the smallest radiators, and the lowest required reactor temperature. It was felt that these considerations outweighed the complexity of two-phase fluid management and liquid metal working fluids. The primary radiator would be 500 to 700 m² in area (assuming a rejection temperature of 1000K), and would be composed of carbon-carbon composite heat pipes with metal liners and potassium working fluid. A tungsten/lithium hydride reactor shadow shield is used to reduce the radiation exposure to less than 1 rem/year at 100m.

For system redundancy and possible compatibility with smaller power generation systems, the conversion system utilizes six one MWe turboalternators, each running from a separate fluid loop from one of the two reactors. The power output from the turboalternators would feed into a cross-strapped power management and distribution system and would subsequently power the electric thrusters. This system architecture provides for graceful degradation in the event of reactor, fluid loop, or turboalternator failures. The power system is illustrated in Figure 14.



Three electric propulsion technologies were considered in this study: ion thrusters, magnetoplasmadynamic (MPD) thrusters, and RF induction plasma thrusters (VASIMR). For the fidelity of the current analysis, all of these systems have roughly the same performance and thruster efficiencies. Figure 15 shows the characteristics of a 1 MWe electric thruster. For this study, 60% jet efficiency was assumed.

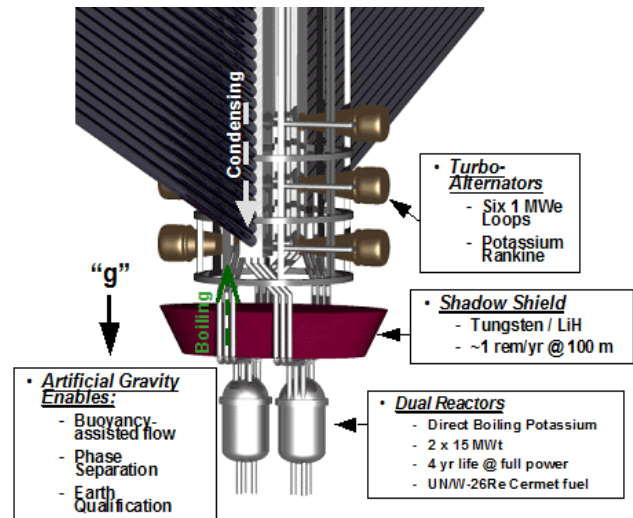

A more important characteristic may be the type of propellant used. Ion and MPD thrusters tend to use high-density propellants. This allows efficient propellant tankage and packaging near the vehicle spin axis. The propellant tanks in Figure 4 are sized for MPD thrusters (lithium, 500 kg/m³) and would be even smaller for ion thrusters (argon, 1400 kg/m³). The propellant of choice for VASIMR, however, is hydrogen, which would have severe configuration impacts for an AG vehicle. It may be possible to fuel a VASIMR thruster with denser fluids, such as deuterium or nitrogen and alleviate some of these issues. VASIMR thrusters were not examined in this study.

Figure 14. Power System

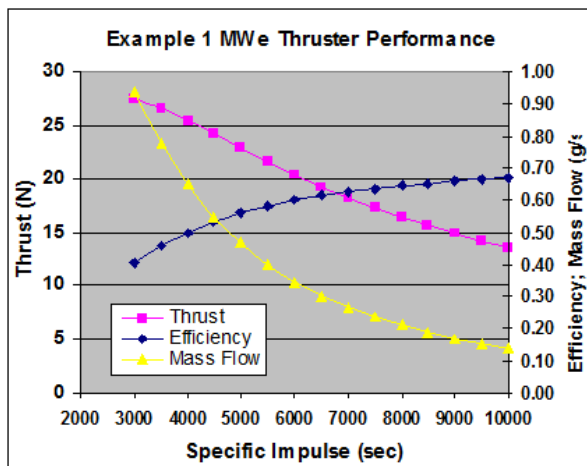

Figure 15. Thruster Performance

Habitation

As mentioned earlier, habitation module designs for missions of the type being considered in this investigation are available from past studies (Ref. 9). Two major differences justified a reexamination, however. One, of course, is the 1-g operational mode. The other is the availability of abundant power from the spacecraft's nuclear power system. Typical power requirements for habitats run in the 10's of kWe - less than one per cent of the reactor power output. For each of the major habitation subsystems, the effects of these two environmental conditions were evaluated. The full report of the habitat module design is included as an attachment.

The following additional architectural level assumptions were made in order to provide necessary guidelines for system leads to develop their concepts:

- Time duration per mission: 18 months
- The habitat will support 6 people
- The initial operational capability will be between 2015-2020
- The transfer vehicle will be reused for subsequent missions
- The vehicle will not be required to perform any aerobraking or entry maneuvers
- Outfitting missions are acceptable
- EVA will be a required function
- There will be no re-supply of consumables during the 18 month mission
- The launching configuration of the habitat portion of the spacecraft should be no larger than 5m X 15m.

Structures

The structure and shell are to provide a safe habitat for the crew and the necessary space to store supplies and equipment to sustain them for the duration of the entire mission. The inflatable module design was chosen because it is the best means to effectively increase the habitable volume of a spacecraft while keeping the diameter of the core within acceptable payload size limits. The airlock system is to provide the crew with the capability to perform extra-vehicular activities. It is located atop the habitat module, so as to allow the fully suited EVA crewmembers easy egress from the module without climbing stairs, ladders, etc.

The primary impact of artificial gravity is the necessity to modify the core into a load-bearing structure. Previous inflatable module concepts had a structure suitable for launch, and were then reconfigured significantly to operate only in microgravity. They contained cloth flooring with inflatable supports, which would be insufficient in a 1-g environment. One solution would be strong, but lightweight composite isogrid deck panels supported by cables (Figure 16). The inner wall of the shell itself should remain unaffected by the 1-g accelera-

tion, however the outer layers may sag outward, thereby compressing the outer shell and reducing the amount of MMOD and radiation protection towards the top of the module.

Thermal Control System

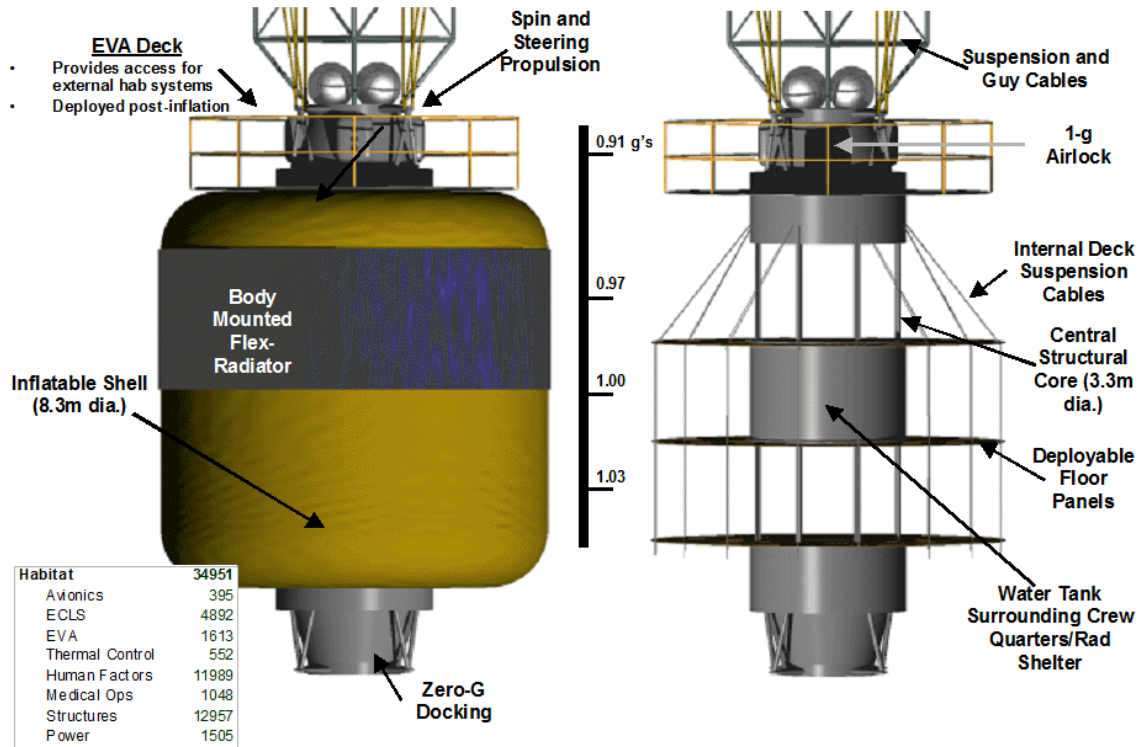

Figure 16. Hab Module Structural Concept

The TCS system concept makes use of flexible lightweight body-mounted radiators that are attached to the outer surface of the inflatable module. The TCS has been sized to collect and reject 15.0 kW of heat. A propylene glycol/water coolant is circulated inside the module to collect heat from heat exchangers and coldplates and this heat is rejected to space through the radiators.

A key issue is the ability of body-mounted radiators to reject heat during all phases of the mission. To evaluate the capability of the radiators an analysis was performed to characterize the environment in four locations: low earth orbit, a location 0.5 A.U. from the sun, a location 1.5 A.U. from the sun, and Mars orbit. The resulting sink temperatures are listed below for the four cases:

Table 4. Sink Temperatures for Key Mission Locations

Low Earth orbit (220 nm)	201.6 °K (-96.7 °F)
0.5 A.U. Heliocentric orbit	222.1 °K (-59.9 °F)
Mars orbit (220 nm)	163.2 °K (-165.8 °F)
1.5 A.U. Heliocentric orbit	129.0 °K (-227.5 °F)

These temperatures indicate that the module will see heat leak in all locations. Radiator size was determined for the warmest case (0.5 A.U. orbit). The results indicate a required area of 78 m². This represents 51% of the available area of the cylindrical portion of the shell.

Operations at 1-g would increase coolant pumping losses by ~10% over microgravity conditions, equating to ~100 W of additional pumping power.

Environmental Control and Life Support System

The Air Management Subsystem is characterized by a 4-Bed Molecular Sieve (217.7 kg, 0.6 m³, 733.9 W), a Sabatier CO₂ Reduction Unit (26 kg, 0.01 m³, 227.4 W), an Oxygen Generation Subsystem (501 kg, 2.36 m³, 4,003 W), and high-pressure storage tanks for O₂ (20.4 kg, 0.78 m³, 6 W) and N₂ (94.4 kg, 3.6 m³, 6 W). The Water Management Subsystem uses a Vapor Phase Catalytic Ammonia Removal system (1,119 kg, 5.5 m³, 6,090.7 W) and potable water storage tanks (145.9 kg, 0.54 m³, 5 W). The Waste Management Subsystem uses a Warm Air Dryer (527.2 kg, 11.2 m³, 2,043.7 W).

Due to the impact of a 1-g environment on fluid pumping systems, consideration will be given to the placement of the ECLSS pumps such that pumping up and/or down will be gravity-assisted.

Components flown at 1-g could be certified in a ground testbed. Alternatively, construction of an appropriate integrated testbed could be performed on the Earth, thereby alleviating the need to fly the equipment for certification purposes for nominal use conditions. However, systems that are needed and couldn't be shutdown during despun operations would still need to be certified for microgravity operations.

After CO₂ reduction is accomplished in the Sabatier, the stream is passed to a phase separator to separate it into a gaseous stream, which is vented overboard, and a liquid stream, which is sent to the OGS. In the presence of Earth-normal gravity, phase separation could theoretically be accomplished with a settling tank. Knowing that the potential exists for limited exposure to a microgravity environment, this is not a likely design specification; rather, the phase separator would be designed with a centrifugal extraction drum inside of it that tilts along the gravity vector in accordance with the gravitational environment.

In general, a fluid system operating in microgravity will also operate under 1-g with no design changes, especially if this potentiality was noted at the time

of vehicle design. There are exceptions to this statement; however, if initial consideration is given to how the gravity vector acts on the system, most aspects of the system can be designed to work in Earth-normal gravity. For example, fans or blowers in a 4BMS drive the stream flow and pumps in a fluid system drive the fluid flow, regardless of the gravitational condition. When sizing the fan or pump, the worst-case scenario will be used.

Two technologies were evaluated for water recovery, the Biological Water Recovery System (BWRS) and the Vapor Phase Catalytic Ammonia Removal (VPCAR) System. A trade study performed determined that the system using the VPCAR, although more power intensive than the BWRS (6,090 W vs. 2,649 W total system power), was preferable due to its lower mass and volume requirements (1,119 kg vs. 1,596 kg mass and 5.5 m³ vs. 8.0 m³ volume). As previously mentioned, the longer turnaround time of the BWRS as well as the large BWRS expendable mass (2,703 kg vs. 243 kg) are other disadvantages. Therefore, the VPCAR system was recommended for this vehicle.

In analyzing the CO₂ removal system, the technologies of 4-Bed Molecular Sieve (4BMS) and Solid Amine Vapor Desorption (SAVD) were evaluated. Although the 4BMS was slightly more mass intensive than the SAVD (218 kg vs. 111 kg) and larger in volume (0.6 m³ vs. 0.2 m³), its ability to recover H₂O was of value in light of the mission duration. As power is not an issue in the vehicle design, ECLSS elects to use the 4BMS as the CO₂ removal technology.

Consideration was given to warm air drying (WAD) and lyophilization (freeze-drying) solid waste disposal options. While the technologies are similar in mass (527 kg vs. 499 kg) and volume (11.2 m³ vs. 11.8 m³), a power comparison demonstrates the more power-intensive nature of the WAD (2,044 W vs. 246 W). Because the technology readiness level (TRL) of the WAD (TRL=8) is expected to remain higher than lyophilization (TRL=5) for the foreseeable future, and based on the longer cycle time of the lyophilization unit, the ECLSS design specifies the WAD technology to process solid waste.

Human Factors and Habitability

The Human Factors and Habitability (HF&H) system includes the galley, wardroom, Waste Collection System (WCS), personal hygiene, clothing, recreational equipment, personal stowage, housekeeping, operational supplies, maintenance, and sleep accommodations.

For the most part, there will be a reduction of complexity in 1-g habitability systems compared with past microgravity spacecraft systems. For example, WCS, personal hygiene systems, and sinks will not need vacuums to control free-floating debris as in microgravity. Also, the galley can be modeled more closely to an Earth-based kitchen with similar types of appliances and food preparation techniques. In order to minimize the amount of consumables required, a dishwasher, clothes washer, and clothes dryer can be incorporated into the design. An additional feature of this habitat as opposed to traditional spacecraft due to the 1-g environment will be the inclusion of beds, chairs,

and other Earth-based comfort items. An example floor plan is given in Figure 17. General designs of the systems will typically be simplified by the similarity of requirements to their counterparts used on Earth. This will help expedite the flight certification process.

The power-rich environment will also permit the consideration of items that are power intensive, yet will help to improve the standard of living onboard the spacecraft. For example, appliances such as incinerators, large freezers, microwave ovens, and convection ovens can now be considered.

Systems Issues

Several systems may have significant impacts on the AG vehicle design and operational characteristics, but were not assessed during this study phase. It is expected that subsequent trade studies and integrated design session can aid in understanding their significance.

Many options were discussed regarding techniques for crew ingress and egress from the AG vehicle. It was assumed that during assembly, refit, and resupply operations, the vehicle would be despin and access to the habitat module could be made via a zero-g docking port. However, during mission operations, many options are possible. The simplest would be to despin the vehicle every time the crew must egress or ingress, but this may be quite involved, as the entire vehicle must be “safed” for micro-g operations, and propellant will be expended for each cycle. An alternative would be to provide crew access to the vehicle hub, allowing egress and ingress while under spin.

The transfer of crewmembers to, for example, a Mars lander, provides another set of options. Again, the AG vehicle could despin and the lander docked to the habitat module. Transfer of the crew to the AG vehicle hub and subsequent transfer to the lander by EVA is another possibility. Docking a lander

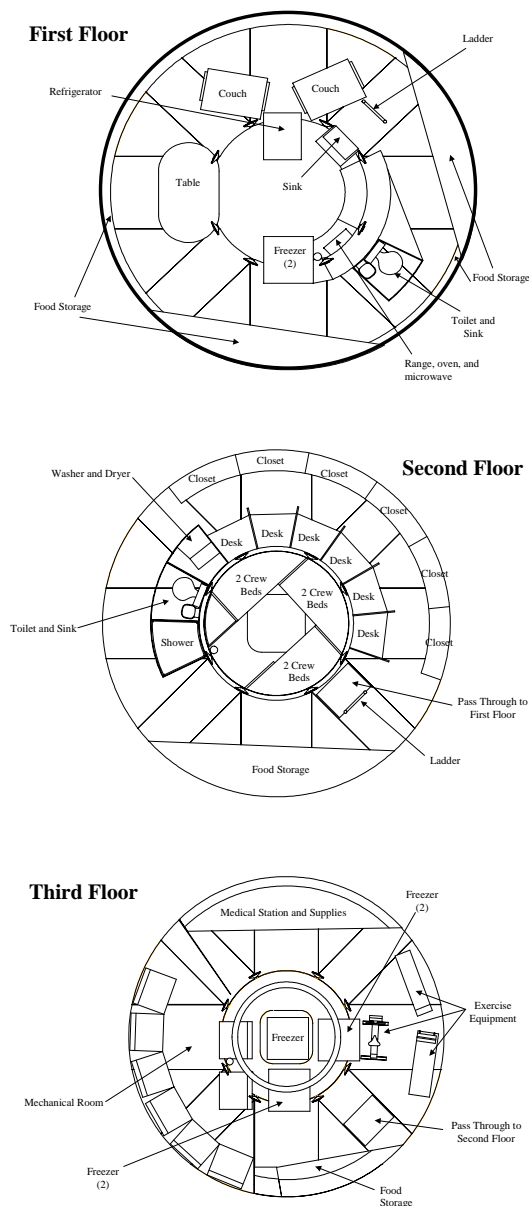

Figure 17. Example Habitat Layout

to the AG vehicle under rotation is probably not a good option, as even a docking at the hub would destabilize the rotational motion.

No rigorous assessment was performed of several other systems that may experience added complexity due to the rotating environment. While photovoltaic arrays will not be required on a nuclear powered vehicle, there are several other components that are typically despun or actively pointed. This study assumed that since modern startrackers are essentially electronic cameras with pattern-recognition software, some sort of image compensation algorithms will computationally “despin” the images. It is hoped that some form of phased-array antenna, or switchable fixed beam antennae combined with the high power levels available will enable high-bandwidth communications downlink without a steerable dish. Another method may be required for uplink, however.

Architectural Issues

Several architectural parameters will need to be addressed prior to more detailed assessment, particularly regarding the archetype mission.

In order to ensure the AG vehicle design is feasible from a launch and assembly standpoint, the matters of assembly location (LEO, L₁, etc.) need to be thought out. Also, the transport mechanism of the vehicle or vehicle components to higher Earth orbit should be evaluated, along with the resupply and refurbishment strategy. The infrastructure required to sustain such a reusable vehicle should be also be considered.

It is critically important to understand the destination planetary orbit. While the “minor axis rotation” technique devised for 180° thrust vector shifts can accommodate a certain degree of planetary spiraling, it is not as efficient or fast as conventional tangential thrusting. If routine travel to low planetary orbits is desired, a different vehicle configuration, similar to Figure 1 (Ref. 4) may be a better choice.

Conclusions

The archetype mission requirements were met with a vehicle concept that incorporated acceptable artificial gravity parameters. Additional improvements in transit time and increases in perihelion distance may be possible with more sophisticated trajectory optimization. The vehicle mass associated with the mission is consistent with previous NEP solutions (Ref. 6, 7, 8).

The major challenge unique to the vehicle configuration chosen for this study was met. Steering strategies were identified consistent with the archetype mission requirements without excessive propellant expenditure.

The vehicle mass penalties associated with artificial gravity incorporation appear minimal (a few per cent). The separation distances associated with space nuclear systems were used advantageously to provide the required rotation radius, and the designs for these structures appear to be very lightweight and efficient. No massive despun joints, interface, etc. were required. There was

good convergence between the power system mass as the habitat counterweight and propulsive performance utilizing reasonable specific power and thruster performance. Multiple spinup/spindown sequences appear unnecessary, again reducing propellant requirements (although as discussed above, crew egress/ingress techniques are TBD).

Future Work

The system and architecture issues identified above must be addressed. In addition a few targeted studies similar to those presented in the attachments may be desirable. A more detailed power system and main radiator design would be of interest, along with radiator construction or deployment strategies. Reactor radiation scattering and shielding assessments would be needed to validate the overall vehicle configuration.

Finally, a more thorough understanding of the forces and moments the AG vehicle will experience while in a despun mode is required. Docking loads, plume impingement forces, maximum maneuvering requirements, etc. may be more significant structural design drivers than the loads identified during AG operations.

References

- ¹*Safe Passage: Astronaut Care for Exploration Missions*, Ball, J.R and C.H. Evans, Jr., editors; Committee on Creating a Vision for Space Medicine during Travel Beyond Earth Orbit, Board on Health Sciences Policy, Institute of Medicine, National Academy Press, Washington, DC, 2001
- ²Shipov, A.A, In: *Space Biology and Medicine*. A.E. Nicogossian, S.R. Mohler, O.G. Gzenko, A.I. Grigoriev, eds. American Institute of Aeronautics and Astronautics, Reston, VA. pp. 349-363.
- ³Diamandis, P.H, In: *Fundamentals of Space Life Sciences, Volume 1*. S.E. Churchill, ed. Krieger Publishing Company, Malabar, FL. pp. 159-175, 1997.
- ⁴Boeing Defense & Space Group, Advanced Civil Space Systems, *Space Transfer Concept and Analysis for Exploration Missions, Final Report Phase One*, Contract NAS8-37857 to NASA Marshall Space Flight Center, Huntsville, Alabama, March, 1991.
- ⁵McDonnell Douglas Space Systems Company – Houston Division, *Integrated Mars Mission Analysis*, January, 19921.
- ⁶George, J.A, *Multimegawatt Nuclear Power Systems for Nuclear Electric Propulsion*, presented at the Ninth Symposium on Space Nuclear Power Systems, Albuquerque, New Mexico, 12-16 January, 1992.
- ⁷George, J.A., K.J. Hack and L.A. Dudzinski, *Fast Piloted Missions to Mars Using Nuclear Electric Propulsion*, AIAA 91-3607, presented at the AIAA/NASA/OAI Conference on Advanced SEI Technologies, Cleveland, Ohio, 4-6 September, 1991.
- ⁸George, J.A., K.J. Hack, L.A. Dudzinski, L.P. Gefert and J.H. Gilland, *Piloted Mars Mission Planning: NEP Technology and Power Levels*, presented at the Tenth Symposium on Space Nuclear Power and Propulsion, Albuquerque, New Mexico, 10-14 January, 1993.
- ⁹*Human Exploration Architecture Study*, Advanced Development Office, NASA Johnson Space Center, Houston, Texas, 1999.

Attachments

Attachment 1

Reference Structural Configuration Development



ABLE Engineering, Inc.
7200 Hollister Avenue
Goleta CA 93117

www.aec-able.com

Tel: 805.685.2262
Fax: 805.685.1369

Reference Structural Configuration Development

for the Artificial Gravity Spacecraft Project

FOR LOCKHEED MARTIN SPACE OPERATIONS

Under Contract No. NAS9-19100

Author _____
Michael E. McEachen

Approved By _____
David W. Messner

Prepared by:	Revision Date:	Document No.:	Revision:
Michael E. McEachen	20 September 2002	3054D1902	Initial Release

Table of Contents

Section	Description	Page
1.0	DESIGN.....	1
1.1	CONFIGURATION BASELINE RATIONALE.....	1
1.2	THE COILABLE BOOM.....	2
1.3	USING GRAPHITE FIBERS IN A LARGE COILABLE.....	3
1.4	HIGH-TENSION APPLICATION PROVISIONS.....	4
1.5	FURTHER OPTIMIZATION OF THE BASELINE STRUCTURE.....	6
1.6	PROVISION FOR POWER CABLE ROUTING.....	6
1.7	DESIGN CONCLUSION.....	7
2.0	ANALYSIS.....	9
2.1	FINITE ELEMENT MODEL.....	9
2.2	LOAD CASE: 4-RPM SPIN.....	10
2.3	LOAD CASE: 100 N THRUST.....	12
2.4	LOAD CASE: 15 N THRUST AT SYSTEM ENDS.....	12
2.5	ALLOWABLE LOAD: SHEAR.....	12
2.6	ALLOWABLE LOAD: TORQUE.....	13
2.7	ALLOWABLE LOAD: BENDING.....	13
2.8	MODES: TORSIONAL AND BENDING.....	14

Figures

Figure 1.	System Assumptions.....	1
Figure 2.	Coilable Boom Terminology.....	2
Figure 3.	AGV System.....	3
Figure 4.	Longeron Rods.....	4
Figure 5.	Longeron Terminal Pivot and Erection Springs.....	5
Figure 6.	Tip Anti-Snap Bridle.....	5
Figure 7.	Cabling.....	7
Figure 8.	Finite Element Model Terminology and Assumptions.....	9
Figure 9.	Longeron Load Distribution from 4-RPM Spin.....	11
Figure 10.	Longeron Deflection from 4-RPM Spin.....	11
Figure 11.	100 N Thruster Load.....	12
Figure 12.	Bending Moment Strength.....	14
Figure 13.	Torsional and Bending First Mode (Core fixed).....	14
Figure 14.	Torsional and Bending First Mode (Core fixed).....	15
Figure 15.	Bending First Mode (Free-Free, Empty Propellant).....	15

Tables

Table 1. Boom Performance Summary..... 8
Table 2. Finite Element Model Mass Properties..... 10

Appendix

Appendix A Subjects for Future Study..... A-1

Reference Structural Configuration Development

1.0 DESIGN

1.1 CONFIGURATION BASELINE RATIONALE

Able Engineering, Inc. (ABLE) is pleased to offer its design concept for deploying and supporting the modules of an Artificial Gravity Vehicle (AGV). See Figure 1 for assumed system. Building upon the core technology behind Coilable Boom structures, ABLE has sought to make these structures even more efficient, and this effort has yielded some exciting and promising concepts, which combined will produce a structure which has no peer in terms of thermal and structural stability, compact stowage volume, and low mass.

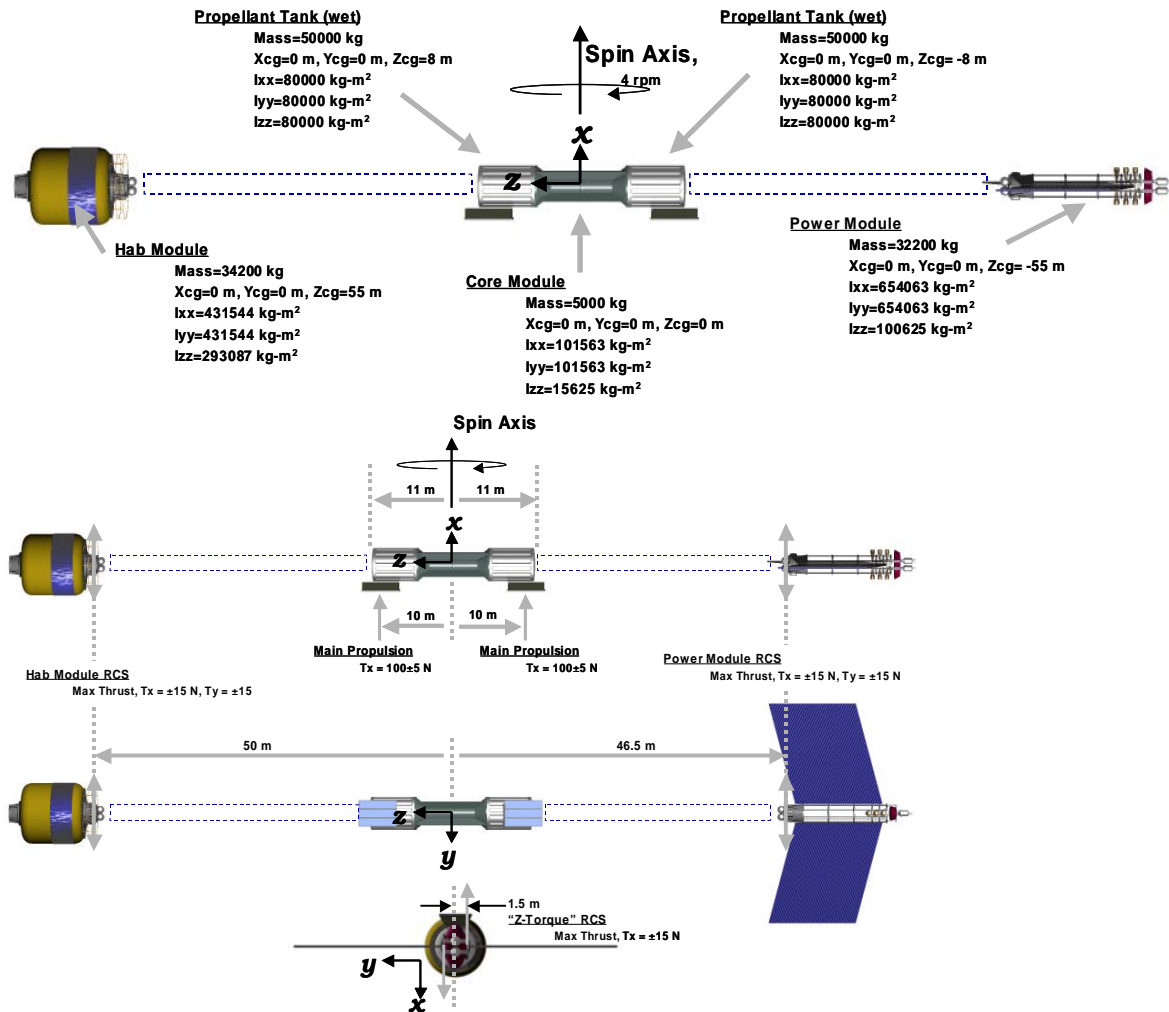

Figure 1. System Assumptions

A candidate mast for the AGV structure initially was the ADAM mast like that used for the SRTM program. However, it immediately became obvious that the challenge of supporting massive centrifugally spun payloads is not well met by the ADAM. The numerous articulated joints along the length of the boom would all need to take the tension of the payload. However, these joints are designed to be loaded in compression, provided by preload in the mast diagonals. Each joint is a single-point failure, and the mass of these joints would be so substantial as to double or triple the system mass. An alternative structure is clearly required.

1.2 THE COILABLE BOOM

The ideal of a rope ladder/tether structure that can take bending and shearing loads is embodied in the Coilable Boom, a staple ABLE structure, as shown in Figure 1. The base form of the Coilable Boom offers impressive performance. Its stowed length defines the current state of the art at approximately 1% of deployed length. It is self-deploying, requiring only a lanyard payout to controllably deploy instead of the massive and complex deployment mechanisms of articulated structures. It is extremely repeatable in its deployed shape since the longitudinal elements are continuous fibers instead of the jointed links of an articulated boom. With a few design accommodations, this structure suits the AGV application perfectly.

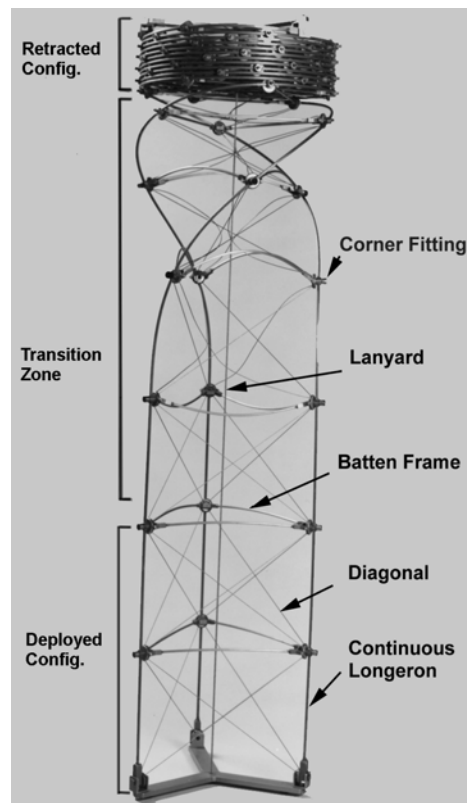

Figure 2. Coilable Boom Terminology

1.3 USING GRAPHITE FIBERS IN A LARGE COILABLE

The AGV boom, seen in Figure 3, addresses the design limitations of the current Coilable Boom. These limitations stem primarily from structural constraints on the amount of strain that may be applied to the longeron elements of the boom when it is stowed. A standard Coilable Boom uses a single rod for each longeron so that for a given boom diameter, a strict limit is imposed on the size of the rod so that the rod is not overly strained when stowed. This has historically led to the use of s-glass/epoxy material for its high strain capability. However, s-glass is not the best material available in terms of stiffness/mass or thermal stability (having a near-zero CTE). Currently this distinction belongs to graphite/epoxy (GrEp) materials.

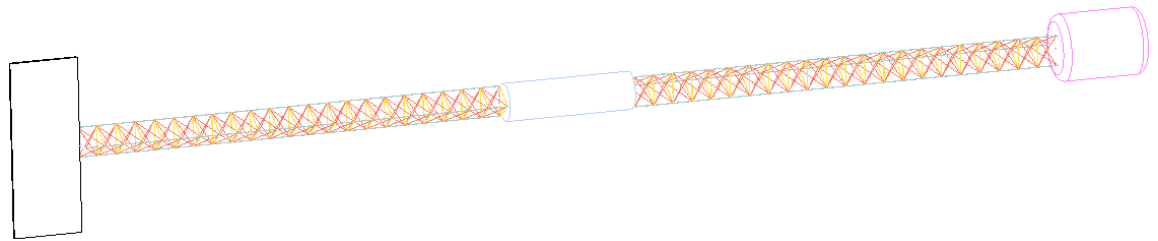

Figure 3. AGV System

The ability to use GrEp materials is provided by the application of a new structural configuration for the longeron elements. This configuration uses a bundle of four small-diameter rods, shown in Figure 4, instead of a single large rod. Combined, these rods possess an equivalent cross-sectional area as the single rod, but are strained less in stowage since strain is proportional to the diameter of the object for a given bend radius.

Using several rods for each longeron also provides improved resistance to Micrometeoroid/Orbital Debris damage. If a particle were to damage a single rod of the bundle, the reduction in stability and strength would be minimal. This can be a major consideration for a large structure with an extended-duration service life, where the probability of a damaging impact can approach unity. Redundant, bundled longerons mitigate the effects of such an impact.

The addition of the parameter of individual rod diameter provides ample design space for tailoring the boom performance, depending on strength or stiffness design goals. Removing the strain limitation from the longeron rods increases the design space for the performance of the boom given a certain diameter. For large diameter booms, these items can become very important. For instance, the boom's deployment push force is a function of the bending stiffness of the longerons. Using large single rods for longerons, this push force can become

impractically large, driving up requirements for the deployment mechanism (lanyard and damper or motor). Additionally, large rods which are strained to near their elastic limit pose a critical personnel and hardware hazard in the event of a failure. The AGV boom's bundles of small rods eliminate this problem, reducing the push force to a level that overcomes the drag of wire harnesses yet does not constitute a personnel hazard.

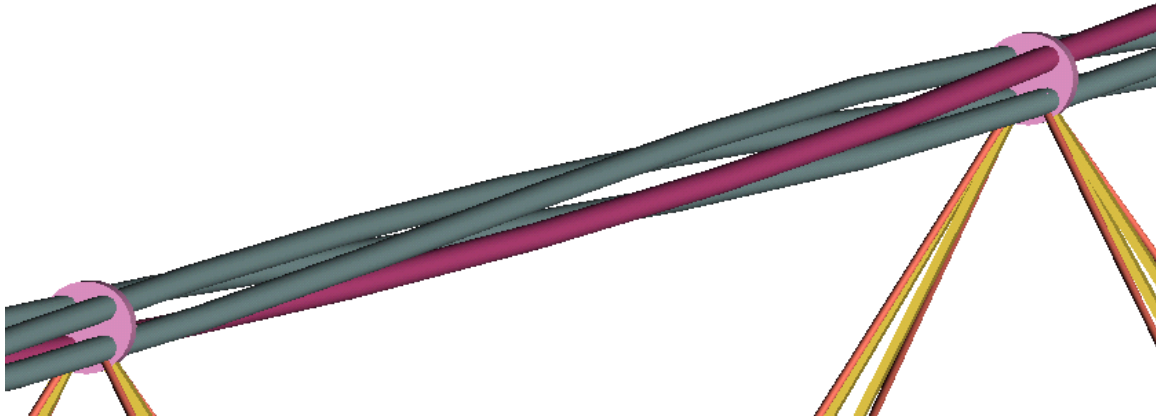

Figure 4. Longeron Rods

1.4 HIGH-TENSION APPLICATION PROVISIONS

Since the Coilable Boom is based on continuous elements along the length, the only structural articulating joints are found at the ends of the boom. These fittings have been considered, since they represent significant mass and are key structural components. The high tension from the spinning configuration means that the longerons must be well terminated to develop the full breaking strength of the longerons. This can be provided by long bonding fittings made of a material closely matching the CTE of the longerons. Matching the fitting and longeron CTE ensures that the bond strength will not degrade after exposure to thermal extremes. The length provides the shear area required to fully anchor each rod. The bonding fitting is restrained by a metallic pivot fitting that has posts for the revolute joint required at the longeron ends. See the exploded view in Figure 5.

This bonding fitting also serves as a lever arm on the end of the longeron that is used at both ends of the mast for two different purposes. At the base of the boom, the lever arms are pulled on by springs that ensure that the boom is erected first at the base (see Figure 5). Without these springs, during deployment the boom would assume a long partially coiled “transition” configuration with minimal structural stability.

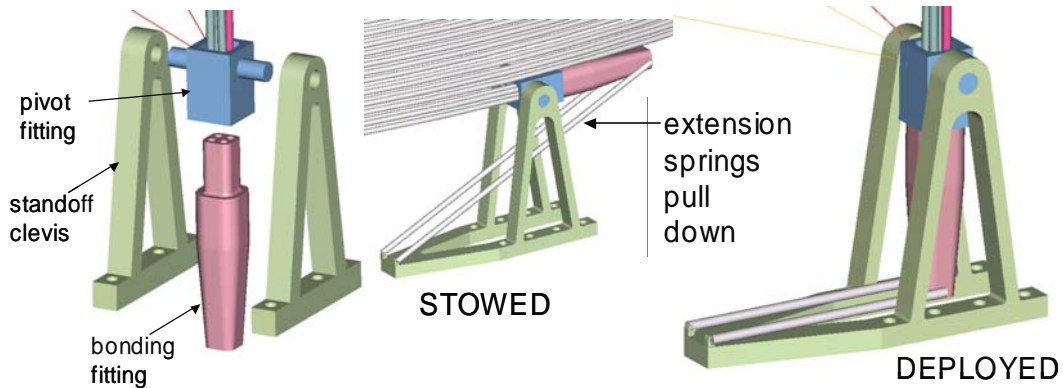

Figure 5. Longeron Terminal Pivot and Erection Springs

The tip of the boom, on the other hand, needs the opposite effect. Near full deployment, the longerons straighten out on the tip pivots, pushing the boom outwards with a force much higher than during the rest of deployment. This means that the lanyard is no longer capable of controlling the motion of the tip and there is a “snap” through the last portion of a coil. This behavior is clearly not acceptable for this application and there is a simple way of preventing it. At the tip end of the boom, the longeron lever arms are integrated with a torque wheel to which a bridle of the lanyard is attached. The tension in the lanyard is transferred to a three-stranded bridle providing a retarding torque to the straightening of the longerons upon full deployment. This torque is opposite of that applied by extension springs at the base of the boom to assist the straightening of the longerons. The bridle-pulley mechanism, shown in Figure 6, is known as a Tip Anti-Snap Bridle, and also allows the boom to be re-stowed after full deployment simply by reeling in the lanyard.

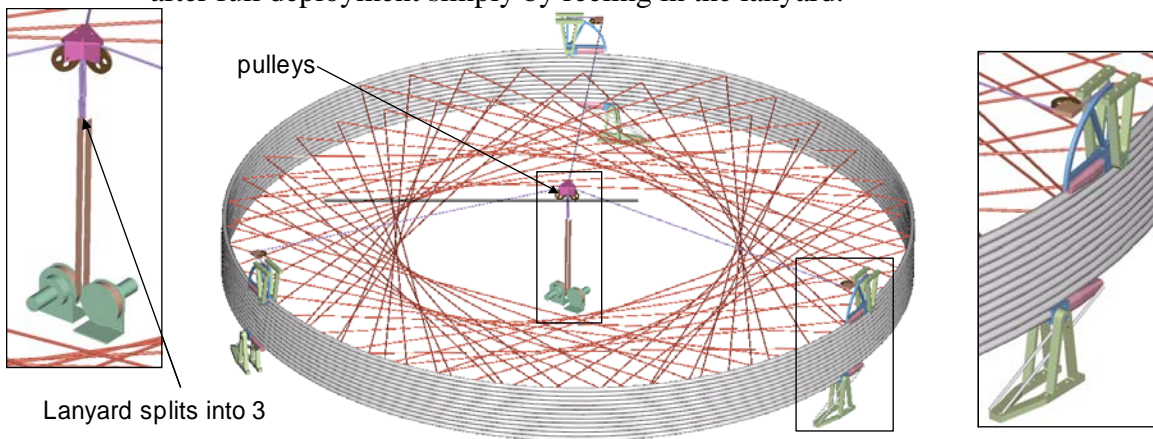

Figure 6. Tip Anti-Snap Bridle

1.5 FURTHER OPTIMIZATION OF THE BASELINE STRUCTURE

During the design investigation consideration was given to the batten elements for ways to improve their mass efficiency. These batten elements are effectively low-stiffness springs which apply a load between longerons which in turn tensions the diagonal elements. A simple buckled rod has traditionally accomplished this. In a large diameter boom, this rod becomes very long, which quickly reduces the push force that it provides ($1/L^2$). In order to maintain adequate push force, the rod must be made much larger. This is essentially parasitic mass, though, since there is no benefit from a stiffer batten with more cross-sectional area. Therefore, a means of reducing the effective Euler buckling length has been devised. This requires a compliant spreader/stabilizer so that the rod maintains its low stiffness/high push force that is essential to reliably preloading the diagonals. As a first cut, this spreader has been modeled as a double leaf spring that limits the bowing of opposing strips. This is a significant mass and volume saver (about 50 lb per 50m boom), since the push force of a given mass of batten strips is multiplied by a factor of 16 using 3 leaf springs per batten element.

1.6 PROVISION FOR POWER CABLE ROUTING

Another benefit of the AGV boom is the fact that utilities may be run directly along the longerons. Since the cabling is fully controlled by the longerons, reliability against hanging up or snarling is guaranteed. This also means that cable harnesses are only required to bend to the radius of the stowed boom. This minimizes the restraint against deployment that wires can cause. Experience at ABLE with the wiring on the SRTM mast and other programs has shown that cables' bending stiffness can be unworkably high under cold conditions. Heaters lining the canister shell of the stowed boom provide a simple solution to the cold cabling problem. By raising the temperature of the cabling from the range of -140°C (fully exposed to cold space) to approximately 0°C , the cabling is sufficiently softened so that it provides no detrimental resistance against deployment.

The configuration proposed for AGV is to have the large power cables tied at each corner fitting adjacent to the longeron bundle, side-by-side, radially outward, as shown in Figure 7. This means that cables as large as the diameter of the longeron bundle may be used without any increase to the stowed length of the boom. There is no hard limit to the number of utilities that are run along the boom, except that the net bending stiffness of utilities remains well below that of the longeron bundle so that deployment is not impeded.

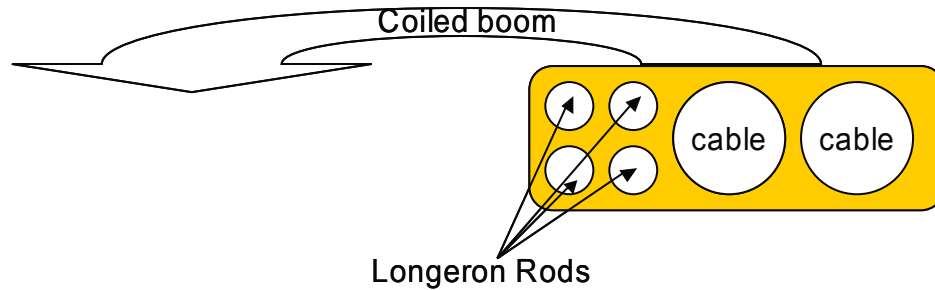

Figure 7. Cabling

1.7 DESIGN CONCLUSION

ABLE has developed a robust, highly efficient structure to serve as the Reference Structural Configuration for the AGV. The performance summary of the structure can be seen in the following Table 1. Using the proven configuration of the Coilable Boom as a foundation, a variant with bundled longeron rods provides the required performance. Additional features incorporated, such as the Tip Anti-Snap Bridle and utilities provisions make this structure perfectly suited to this application. ABLE is confident that the concept presented herein would perform as expected and that the technology to make it a reality could be developed quickly and with little program risk.

Table 1. Boom Performance Summary

Variables	
Boom Length (in)	1968.50
Boom Diameter (in)	157.48
Single (S) or Double (D) Laced	s
Cable Harness Weight (lb)	0.00
Tip Mass (lb)	66000
Tip Rotational Inertia About Boom Axis (lb-in ²)	n/a
Spacecraft Mass (lb)	n/a
Spacecraft Inertia (lb-in ²)	n/a
Controlled-Variables	
Bay Length (typically 0.575 Diameter) (in)	89.477
Longeron Tensile Modulus (psi)	5.00E+07
Longeron Bending Modulus (psi)	5.00E+07
Max Bending Strain (max .005 in/in for GrEp)	0.002
Maximum Longeron Dimension (in)	0.320
Minimum Longeron Dimension (in)	0.320
Longeron Cross Section Type	round
Cross Sectional Area of Longeron (in ²)	0.3217
Minimum Cross Sectional Inertia of Longeron (in ⁴)	2.0589E-03
Maximum Cross Sectional Inertia of Longeron (in ⁴)	2.0589E-03
Density of longeron material (lb/in ³)	0.059
Radius of Longeron (in)	0.16
Steel (S) or Fiberglass (F) diagonals	f
Diagonal Modulus (lb/in ²)	2.00E+07
Diagonal Diameter (in)	0.1
CTE of longeron (in/in/degree F)	-2.00E-07
Batten push force (lb)	41.57
Batten Modulus (in)	5.00E+07
Boom Performance	
Boom Weight (lb)	212.81
Bending Stiffness (EI) lb-in ²	1.50E+11
Buckling Strength (pin-pin) lb	3.81E+05
Bending Strength (M critical) in-lb	2.21E+04
Shear Stiffness (GA) lb	1.81E+05
Shear Strength (lb)	41.57
Torsional Stiffness (GJ) lb-in ²	5.60E+08
Torsional Strength (in-lb)	4909.77
Deployment Force (minimum) lb	24.91
Diagonal Tension(lb)	48.68
Boom Stowed Height (in)	13.85
Cantilevered Natural Frequency (Hz)	0.09
System (dumbell) Natural Frequency (Hz)	n/a
Torsional Frequency (Hz)	n/a
Thermal Distortion (degrees tip rotation/°F)	-0.0002
Number of Corner groups	66
Number of Bays	22
System Characteristics	
System Weight (lb)	289.06
System Diameter (in)	160.48
System Stowed Length (in)	23.6

2.0 ANALYSIS

2.1 FINITE ELEMENT MODEL

A finite element model (FEM) was created to verify the performance predicted by empirical formulas used in the spreadsheet (summarized above). This model verified the loads induced on the booms by thrusters and by the centrifugal force of the 4-RPM spin. Below, Figure 8 illustrates the assumptions and terminology used for the FEM. Following that is Table 2 showing its Mass Properties.

Note that the FEM and the spreadsheet have a 50m boom. This is the value used in the study contract definition. The value in the NASA NEXT slides from Figure 1 indicates a 39m boom. All analysis and design are based on a 50m boom.

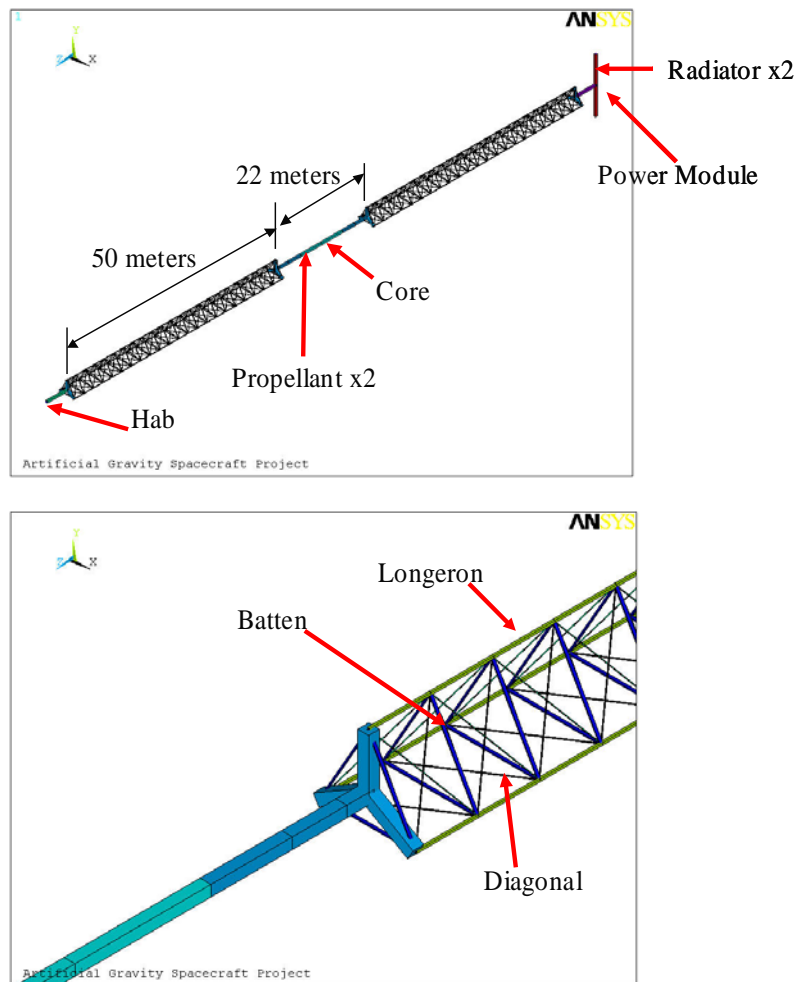

Figure 8. Finite Element Model Terminology and Assumptions

Table 2. Finite Element Model Mass Properties

TOTAL MASS

Mass	Lb	Kg
991.3	382740.93	173610.15

CENTROID

XC (in)	0.0000
YC (in)	0.0000
ZC (in)	0.0000

MOMENT OF INERTIA ABOUT ORIGIN

	Mass-in ²	Lb-in ²	Kg-m ²
IXX	2709600000	1046176560000	306155887.4
IYY	2708700000	1045829070000	306054197.0
IZZ	5971500	2305596150	674715.8

***** MASS SUMMARY BY ELEMENT TYPE *****

TYPE	MASS	Lb	Kg	
21	195.281	75397.99	34200.31	Hab
22	28.5499	11023.12	5000.05	Core
23	183.861	70988.73	32200.28	Power Modul
24	11.4199	4409.22	2000.01	Radiator
25	570.997	220461.94	100000.88	Propellant
31	0.81344	314.07	142.46	Longeron
32	0.329013	127.03	57.62	Batten
33	0.0516817	19.95	9.05	Diagonal
	Sum=	382742.06	173610.66	

2.2 LOAD CASE: 4-RPM SPIN

The first load case considered is that due to the spinning of the AGV. This is clearly the design driver for the system, determining the cross-section area required in the longerons, as well as the method used to terminate the longerons. This spinning was determined to produce a tension of 29,633 lb (131,814 N) in the longerons, with a resulting stress of 93 ksi. The longeron material has a 353 ksi allowable stress. This leaves a factor of safety of 3.8 (See Figure 9).

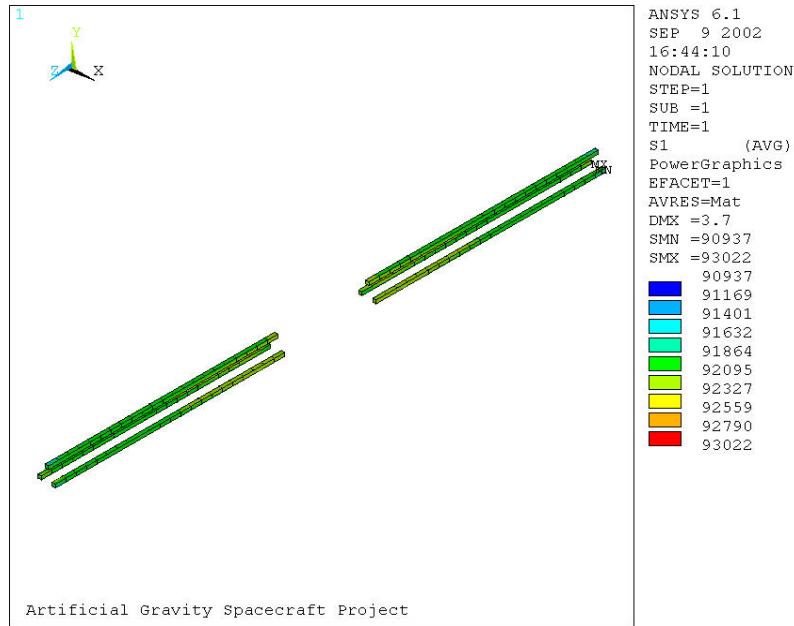

Figure 9. Longeron Load Distribution from 4-RPM Spin

In the following, Figure 10 illustrates the deflection (axial stretch) in the boom due to the tension. The maximum deflection at the ends is about 4 inches. This stretch must certainly be factored into the dynamics of the spinning system.

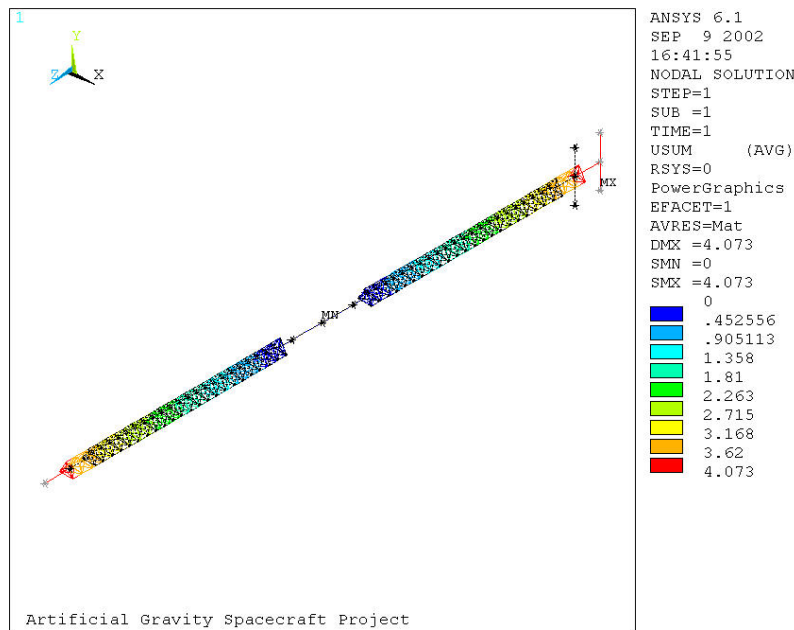

Figure 10. Longeron Deflection from 4-RPM Spin

2.3 LOAD CASE: 100 N THRUST

The next load to be considered is the 100 N load from the main propulsion thrusters. This was modeled as an applied gravity load in order to get a 22.5 lb (100 N) reaction at the thruster location. This load, as seen in Figure 11, produces a shear of 8.9 lb and a moment of 19,600 in-lb at the base of the mast.

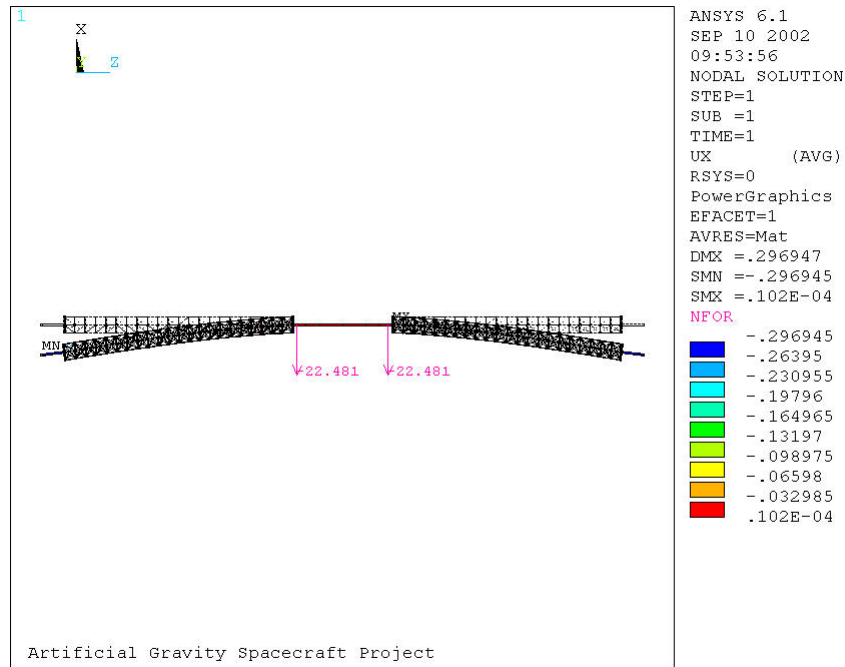

Figure 11. 100 N Thruster Load

2.4 LOAD CASE: 15 N THRUST AT SYSTEM ENDS

Other loads are due to the 15 N thrust at the Habitat and Power Module ends of the booms. This thrust produces a shear load of 3.4 lb, and a moment of 6,638 in-lb. The 15 N thrust at the Core module produces a boom torque of 398 in-lb. In summary, the worst-case loads are a shear of 8.9 lb (100 N main propulsion thrust) and a bending moment of 19,600 in-lb (100 N main propulsion thrust). If the thrusters at the boom ends (Habitat and Radiator) increase by a factor of 10, a shear load of 34 lb and a bending moment of 66,380 in-lb are produced. This load then becomes the design driver.

2.5 ALLOWABLE LOAD: SHEAR

The allowable shear load on the boom is based on the buckling force of the batten.

$$\text{Buckle Force} = \frac{\pi^2 \times E \times I}{L^2} = \frac{\pi^2 \times 5e7 \times \frac{1}{12} \times 0.34 \times 0.12^3}{34^2} = 21 \text{ lb}$$

There are two battens in effect so the total force is 42 pounds. The maximum applied is 8.9 pounds (34 lb for 10x load case) leaving a factor of safety of 4.7 (1.2 for 10x case).

2.6 ALLOWABLE LOAD: TORQUE

The allowable axial torque load on the boom is also based on the buckling force of the batten, acting at the effective radius of the boom's diagonals.

$$\text{Torsional Allowable} = \frac{\Theta}{2} \times 3 \times \cos(60) \times \left[2 \times \frac{\pi^2 \times E \times I}{L^2} \right] = \frac{157.48}{2} \times 3 \times \cos(60) \times \left[2 \times \frac{\pi^2 \times 5e7 \times \frac{1}{12} \times 0.34 \times 0.12^3}{34^2} \right] = 4910 \text{ in-lb}$$

The maximum torque applied is 398 in-lb due to the z-torque RCS thruster load, leaving a factor of safety of 12.3.

2.7 ALLOWABLE LOAD: BENDING

The allowable bending moment applied to the boom is based on the following hand calculation:

$$\text{Buckle Moment} = 4 \times r \times \left(\frac{1.44 \times \pi^2 \times E \times I}{L^2} \right) = 4 \times 120.95 \times \left(\frac{1.44 \times \pi^2 \times 5e7 \times \frac{1}{4} \times \pi \times \left(\frac{0.32}{2} \right)^4}{89.477^2} \right) = 22,103 \text{ in-lb}$$

This calculation, shown below in Figure 12, includes a factor of 1.44 on the Euler buckling strength of the longerons. Known as a “fixity factor,” this value was determined by the FEM and matches values observed in previous Coilable Booms. The FEM shows that the longerons buckle at a tip load of 11.257 pounds, equal to a moment of 22,159 in-lb. The maximum applied moment is 19,600 in-lb from the 100 N primary thrusters, leaving a factor of safety of 1.13. Such a low factor of safety is not unusual on bending strength, since bending failure is purely elastic and damage to the structure would not result in the event of an overload.

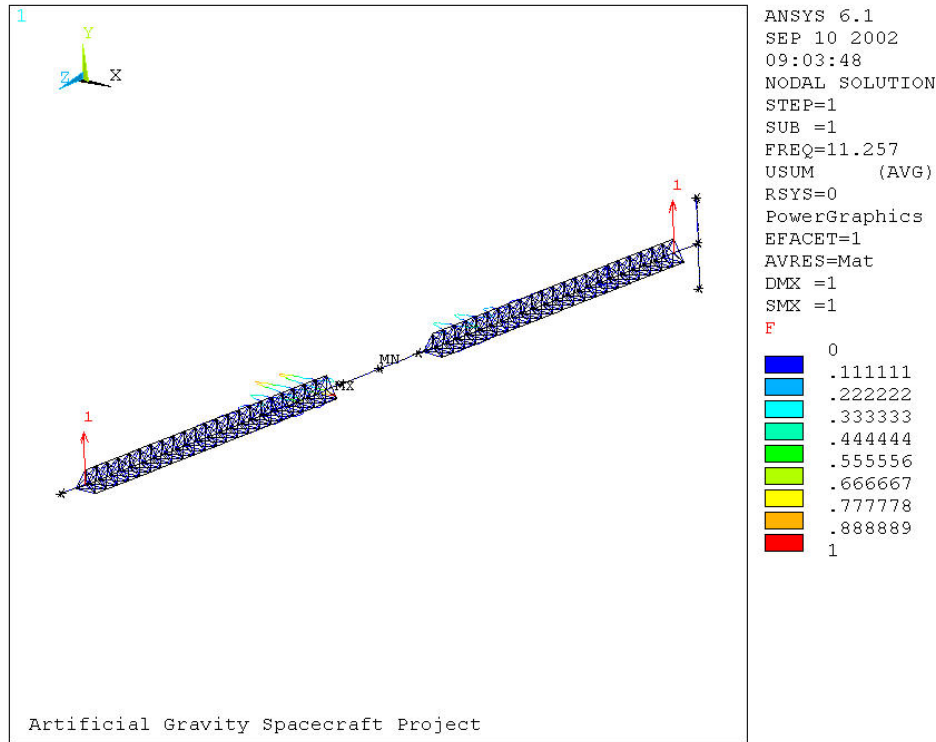

Figure 12. Bending Moment Strength

2.8 MODES: TORSIONAL AND BENDING

Next, the torsional and bending modes were investigated. The assumption of a fixed core module provided a first torsional mode of 0.052 Hz, and a first bending mode of 0.062 Hz (See Figure 13).

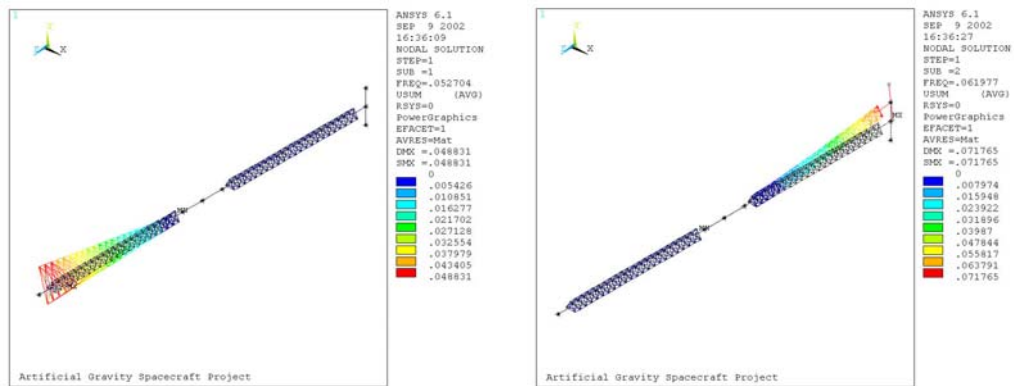

Figure 13. Torsional and Bending First Mode (Core fixed)

With the system considered a free body in space (Free-Free), the values are a first torsional mode of 0.057 Hz, and a first bending mode of 0.079 Hz (See Figure 14).

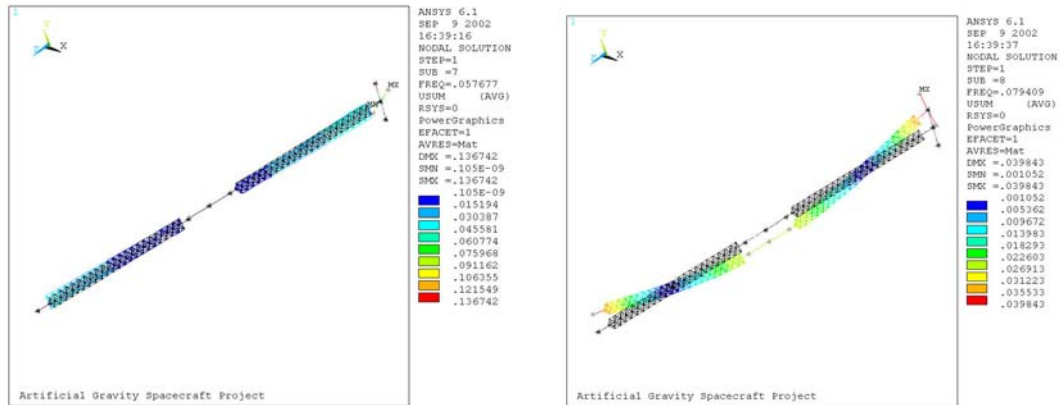

Figure 14. Torsional and Bending First Mode (Core fixed)

Next, the same “Free-Free” case was considered, but with an empty propellant tank, shown in Figure 15, reducing the mass of the core module by 90%. For this case, the torsional frequency remains the same, while the bending frequency increases to 0.144 Hz.

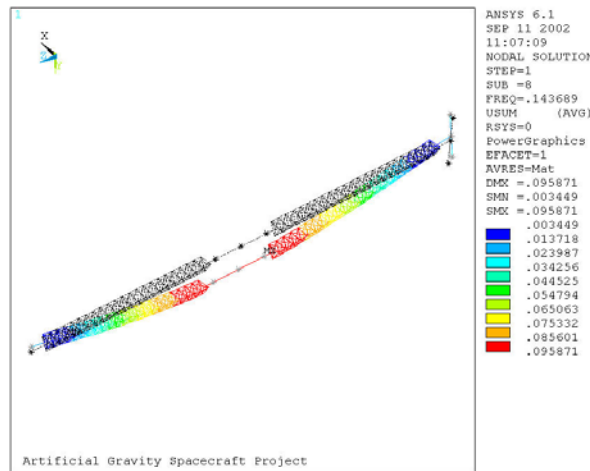

Figure 15. Bending First Mode (Free-Free, Empty Propellant)

Appendix A
Subjects for Future Study

1.0 SUBJECTS FOR FUTURE STUDY

This study has provided a conceptual technical solution to the problem presented. However, increased knowledge and reduced risk may be gained by further pre-program technical development. One effort would be to provide a detailed summary of performance headroom, showing the impact of various requirements on the boom's performance. This would be helpful in system-level trade study, and create the most efficient system-level solution. For example, the boom may be "double-laced" along all or only a portion of its length to increase torsional and bending performance by a factor of 2 for a nominal mass increase. Another example of design headroom is in overall boom sizing. It is possible to increase bending frequency by a factor of 1.75 for a 1.4 factor increase in boom mass. Likewise torsional frequency may be increased 1.5x for a 1.25x increase in boom mass. If structural attachment at the Modules is based on a square footprint, a four-sided (rather than the baseline three-sided) mast may be readily configured, simplifying the interface between boom and Module. Fully understanding the sensitivity to these design parameters would be invaluable information for the system designer.

Since ABLE is known for its hardware-oriented product development approach, a scale model could be built for testing and demonstration of the multi-stranded longeron bundle concept to verify that its performance is as predicted. The coupling that allows the boom to be connected at one end to an adjacent module could be conceptualized. Other potential hardware development could be to verify the strength and reliability of the structural longeron terminals. This effort would be a worthwhile investment in the understanding of the problem and in the reduction of program risk.

Attachment 2

Artificial Gravity Habitat Phase I - Final Report

Artificial Gravity Habitat Phase I – Final Report

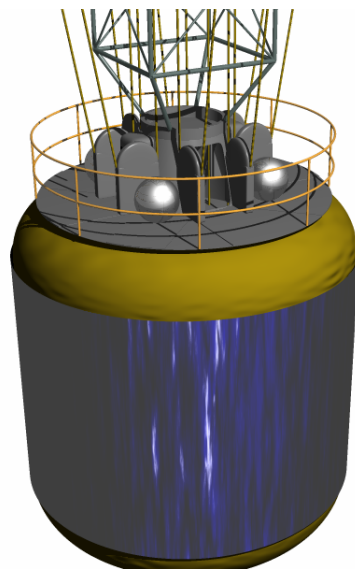

Advanced Design Office Manager
Joyce Carpenter

Architecture Leads
Kent Joosten
Steve Hoffman
Jeff George

Study Lead
Jon Lenius

Submitted: August 14, 2002

Table of Contents

INTRODUCTION.....	3
EXECUTIVE SUMMARY.....	4
SYSTEM SUMMARY.....	5
AVIONICS SYSTEM.....	6
ENVIRONMENTAL CONTROL AND LIFE SUPPORT SYSTEM.....	8
EXTRA-VEHICULAR ACTIVITY	12
THERMAL CONTROL SYSTEM	15
HUMAN FACTORS AND HABITABILITY	19
MEDICAL OPERATIONS.....	23
STRUCTURES AND MECHANISMS	28
ELECTRICAL POWER SYSTEM.....	31
CONCLUSIONS	34
FUTURE WORK	38
APPENDIX A – ACRONYMS	39
APPENDIX B - ECLSS SYSTEM DIAGRAM.....	40
APPENDIX C - INTERNAL HABITAT LAYOUT.....	41

List of Tables

TABLE 1.	System Summary.
TABLE 2.	EVA Subsystem Masses and Volumes.
TABLE 3.	PLSS Component TRLs.
TABLE 4.	TCS Subsystem Summary.
TABLE 5.	Key Location Sink Temperatures.
TABLE 6.	Habitat Heat Losses at Key Locations.
TABLE 7.	HF&H Subsystem Summary.
TABLE 8.	Medical Operations System Summary.
TABLE 9.	Structures and Mechanisms Masses.
TABLE 10.	Electrical Power System Masses and Volumes.

List of Figures

FIGURE 1.	Artificial Gravity Habitat Proposed Thermal Control System Schematic.
-----------	---

Introduction

The purpose of this advanced design study was to gain a better understanding of the impacts to system designs for a space-based habitat, if the habitat were to operate in a 1-g, power-rich environment. The following additional architectural level assumptions were made in order to provide necessary guidelines for system leads to develop their concepts:

- Time duration per mission: 18 months
- The habitat will support 6 people
- The launch date will be between 2015-2020
- The transfer vehicle will be reused for subsequent missions
- The vehicle will not be required to perform any aerobraking or entry maneuvers
- Outfitting missions will be allowed
- EVA will be a required function
- There will be no re-supply of consumables during the 18 month mission
- A Transhab-based design should be used for the habitat and modified only to the extent needed so as to meet the requirements of this vehicle
- The launching configuration of the habitat portion of the spacecraft should be no larger than 5m X 15m.

Once the system concepts were created around these assumptions, the implications of the following two deviations were examined: operating in a microgravity environment for a period of up to 7 days and extending the systems' use from 18 to 24 months.

The following document contains the results of Phase I for this advanced design study. Phase I included a two week integrated design study followed by three weeks of system lead follow-up to address outstanding issues. As products for Phase I, system leads were instructed to present initial system concepts. They were also instructed to supply a report discussing the following topics:

- Major system features including: mass, power, and volume
- Functionality of the selected concept
- Issues, challenges, pros/cons of selected concept
- Impact of the 1 g environment to system design
- Impact of the power-rich environment to system design
- Implications of operating in a microgravity environment for up to seven days
- Impacts of Extending System's Use from 18 to 24 Months.

The following is a compilation of these reports.

Executive Summary

Upon analyzing the impacts of a 1-g, power-rich environment on a space-based transit vehicle, it was found that many new trade spaces were opened to the designers that were previously not available for traditional spacecraft. However, in the same token, it was found that a number of engineering and operational challenges were also introduced. Aside from the technical challenges that will need further investigation in follow-on studies, the perceived benefits for crewmembers on long-duration missions could prove to be invaluable.

The obvious benefits from conducting long-duration missions in a 1-g environment are the positive effects this would have on the musculoskeletal and cardio-pulmonary systems when contrasted with a micro-gravity environment. Allowing crewmembers to live and work in a 1-g environment would alleviate gravity field re-adaptation problems during exploration class missions and also help mitigate possible permanent side-effects of extended micro-g exposure. In addition to the crew, system designers will be benefited by the 1-g environment. Allowing the engineers to model their designs after Earth-based systems will help expedite the “design, test, build” cycle. It is believed that this will help to decrease the cost while improving the overall reliability of the spacecraft.

Introducing a gravitational environment also introduces a few technical and operational problems to the spacecraft design. For example, it may be necessary at times to de-spin the vehicle, thus creating a micro-g environment. Therefore, systems would either have to be capable of working in a variable gravitational environment or be required to be shutdown/safed during the de-spun period. If the latter were required, operational procedures would have to be planned and executed before the spacecraft were commanded to de-spin.

The introduction of a power-rich environment to a spacecraft helped to open trade spaces that were once not available. New appliances could be considered such as incinerators, freezers, dishwashers, clothes washers, and clothes dryers. System components that were smaller in volume, yet required more power could be considered such as Warm Air Dryers (WADs) as opposed to lyophilization units for waste disposal. A power-rich environment also promises to enhance the capabilities of communication systems through the use of high powered signals.

After reviewing the results from this phase of the artificial gravity habitat study, it is clear that further investigation is required before crew benefits and system impacts are fully understood. Discrepancies in data regarding peoples’ ability to adapt to various rotational rates and multiple gravitational environments within a habitat are two major concerns. Habitability requirements to help alleviate psychological strains during long-duration confinement should also be explored. It would be desirable to perform a more detailed system analysis in order to better understand the impacts that the 1-g, power-rich environment present to system designs. Finally, it would be useful to investigate the use of modules other than Transhab. Although a 1-g version of a Transhab-type module may ultimately be decided upon, the trade space should be explored in a future study for using a hardshell or other types of inflatable modules.

Overall, despite the technical challenges and unanswered medical questions, artificial gravity looks to be a promising solution to one of explorations largest problems. The addition of a power-rich environment serves to improve the standard of living for the crewmembers and helps to simplify system designs. These two exceptions to traditional spacecraft rules working in concert with each other will certainly help to redefine the way in which we think about exploration class missions.

System Summary

Table 1 summarizes all of the system leads' data:

TRANSIT HABITAT		
Transit Habitat Inbound Mass	Mass (kg)	Stowed Vol. (M3)
1.0 Power System	1505	17.98
Battery System	485	0.44
Wiring	396	16.49
Power Management and Distribution	625	1.05
Margin	0.0%	0.0%
2.0 Avionics	395	1.00
Comm	169	0.16
Voice Peripherals	4	0.01
DMS	35	0.50
INS	39	0.05
Attitude Initialization	6	0.01
Displays & Controls	14	0.01
Video	8	0.01
Wiring	121	0.25
Margin	0.0%	0.0%
3.0 Environmental Control & Life Support	5030	31.50
Atmosphere Control	1133	4.67
Atmosphere Revitalization	1021	3.25
Temperature and Humidity Control	113	6.32
Fire Detection and Suppression	13	0.05
Water Recovery and Management	2199	6.02
Waste Management	550	11.19
Margin	0.0%	0.0%
4.0 Thermal Control System	576	2.43
ITCS	135	0.34
ETCS	167	0.13
Radiators	274	1.96
Margin	0.0%	0.0%
5.0 Crew Accommodations	11989	91.03
Galley and Food System	8063	31.35
Wardroom	194	6.78
Waste Collection System	327	8.83
Personal Hygiene	283	5.00
Clothing	438	1.91
Recreational Equipment and Personal Stowage	150	3.00
Housekeeping	215	3.61
Operational Supplies and Restraints	120	0.01
Maintenance	1092	5.91
Sleep Accommodations	120	2.82
Other	987	21.81
Margin	0.0%	0.0%
6.0 EVA Systems	1613	16.29
Suits	690	4.15
Vehicle Support	291	0.40
Translation Aids	123	3.36
Tools	132	0.20
Airlock	377	8.18
Margin	0.0%	0.0%
7.0 Structure	12941	84.51
Fixed Elements	5068	2.55
Deployed Elements	7873	81.96
Margin	0.0%	0.0%
8.0 Med Ops	1048	6.17
Human Research Facility	289	2.50
Crew Health Care Systems	759	3.67
Margin	0.0%	0.0%
Total Transit Habitat Mass and Volume	34050	244.729

Total Internal Volume (m³)	350.0
Habitable Volume (m³)	193.0
Required Habitable Volume (m³)	101

Avionics System

Major System Features

The major Avionics system features for the Artificial Gravity Habitat (AGH) include a communication system; a guidance, navigation and control system; a crew interface system; and an integrated vehicle management system.

The following parameters summarize the physical characteristics of the sum of all of the above features:

- Mass: 395 kg
- Total Peak Power: 864 Watts
- Total Volume: .75 m³

Functionality

The Avionics system for the Artificial Gravity Habitat (AGH) provides for the command, control, communications, and computation required for the carrying out the mission including insertion into Low Earth Orbit, transit to Mars, and return to Earth. This involves provisions for crew displays; data, voice, and video communications with Earth, the Martian surface, other orbital assets, and EVA crewmembers; an integrated health management system for onboard and ground monitoring of all systems; and a full flight system capability for Guidance, Navigation, and Control. The flight system must also integrate requirements for data communication and computational support for remote commanding of the AGH during the uncrewed phase as well as ground commanding during crewed phases. The crew interface must be integrated with data communications and computational support for remote commanding of visiting vehicles by the AGH.

These above provisions reside in the context of human flight critical operations and, therefore, must meet the associated reliability requirements.

Issues, Challenges, Pro/Cons

The placement of avionics hardware, particularly antenna placement and sizing, and specification of bus types and instrumentation types (wireless, wire, power bus, etc) cannot be determined until more definition is given to the structural layout and the operational concept. From a structural layout point of view, types of antennas such as dishes, phased arrays, or inflatable dishes would be selected based on whether there were locations that met appropriate mounting structure and visibility requirements. These antenna placements could be affected by structural elements like guy wires because of both physical interference and conflicts in electrical operation. In addition, placement of inflatable antennas could be affected by the deformation produced by the artificial gravity when located away from the center of rotation. If the axis of rotation pointed in the desired direction of communication, then antennas could be placed almost anywhere on that side of the structure; the exception being, perhaps, the inflatable antenna for the aforementioned reasons.

Impact of the 1-g Environment

A 1-g environment has little implications to the avionics system as a whole as evidenced by the many functioning ground systems of similar nature. The one significant area of interest could be in the potential use of convective cooling where there might be a high preference for it. For example, it might be desirable to locate a powered component someplace that might be remote from the main cooling lines and cold plates.

Impact of Power-rich Environment

With a power-rich environment, redundancy for computation and instrumentation could be enhanced although this would be limited, perhaps, by mass and volume requirements. While transmission power for communications could be increased therefore reducing antenna size or increasing coverage; reception, which is limited by the signal-to-noise ratio, would still require larger size antennas. In certain situations, there could be an advantage to using power consuming, less efficient, cooling techniques like Peltier cooling.

Implications of Operating in Microgravity Environment for Limited Duration

Operation in a microgravity environment would only be an issue if some system component depended on natural convective cooling which is not likely to be the case for any critical component.

Impacts of Extending Systems Use from 18 to 24 months

Extending operations from 18 to 24 months only affects reliability requirements of the system components. However, the system level requirement to be reusable with minimum maintenance between missions may dominate reliability requirements anyway.

Environmental Control and Life Support System

Major System Features

The Air Management Subsystem is characterized by a 4-Bed Molecular Sieve (217.7 kg, 0.6 m³, 733.9 W), a Sabatier CO₂ Reduction Unit (26 kg, 0.01 m³, 227.4 W), an Oxygen Generation Subsystem (501 kg, 2.36 m³, 4,003 W), and high-pressure storage tanks for O₂ (20.4 kg, 0.78 m³, 6 W) and N₂ (94.4 kg, 3.6 m³, 6 W). The Water Management Subsystem uses a Vapor Phase Catalytic Ammonia Removal system (1,119 kg, 5.5 m³, 6,090.7 W) and potable water storage tanks (145.9 kg, 0.54 m³, 5 W). The Waste Management Subsystem uses a Warm Air Dryer (527.2 kg, 11.2 m³, 2,043.7 W). Refer to Appendix B for a diagram of the ECLSS system.

Functionality

The function of the Air Management Subsystem is to provide a clean atmospheric environment for the crew. A 4-Bed Molecular Sieve (4BMS) revitalizes the air stream exiting the cabin. Carbon dioxide generated by the crew is removed by a 4BMS Regenerative CO₂ Removal System (RCRS). The 4BMS typically uses a Zeolite molecular sieve material to absorb CO₂ and H₂O with separate canisters for each substance. The air stream from the cabin is first passed through a desiccant bed for water removal to bone-dry conditions. The CO₂-rich stream coming out of the desiccant bed is then passed through the 4BMS for CO₂ removal. The warm air stream coming out of the molecular sieve bed is used to desorb the water content in the desiccant bed and regenerate the desiccants. The revitalized water is returned to the crew quarters.

In order to reduce the large amount of O₂ resupply, a Solid Polymer Electrolysis (SPE) Oxygen Generation Subsystem (OGS) is used for O₂ generation. Water electrolysis produces O₂ and H₂ as a side product, which is used as a reactant in a Sabatier Reduction Unit to reduce CO₂ into water and methane according to the reaction $\text{CO}_2 + 4 \text{H}_2 \rightarrow \text{CH}_4 + 2 \text{H}_2\text{O}$. The CH₄ is vented while the H₂O is further polished and used as an OGS feed stream to generate O₂.

Oxygen and nitrogen are stored at 30 MPa in Hexel high-pressure storage tanks. Three days' storage of metabolic O₂ in the oxygen tank allows time for the OGS to attain its daily production rate. Nitrogen will be stored in the N₂ tank to compensate for leakage in the cabin and repressurization requirements during the mission duration. Sufficient amounts of O₂ and N₂ will be stored to allow for initial vehicular inflation.

A Water Management Subsystem (WMS) serves to recover potable water from waste water streams in order to reduce the amount of water ordinarily provided by resupply vehicles. The major feature of the WMS is the Vapor Phase Catalytic Ammonia Removal (VPCAR) system. The VPCAR has been chosen for the AGH study due to its lower system mass and volume and, in part, due to its shorter turnaround time than its biological competitor, although it is a more power-intensive technology.

It is assumed that a three-day water supply will be stored prior to launch for use until the VPCAR is in operation. Aluminum potable water storage tanks provide hygiene water and drinking water to the crew. Rehydration water is provided to the galley for use in meal preparation. Residual waste water and urine will be collected in waste water storage tanks.

In order to reduce storage space for solid waste, the Warm Air Drying (WAD) technology is selected for use by the Waste Management Subsystem. Solid waste from the cabin and human

solid waste are processed individually. An activated charcoal-filled canister with a Nomex cloth lining is used as the odor and trace contaminant removal means for fecal processing.

Issues, Challenges, Pros/Cons

In considering a recommended cabin pressure, flammability issues were of primary concern. Current material flammability certifications exist for an atmospheric oxygen percentage of up to 30%. This acceptable flammability certification rating of 30% O₂ was used in conjunction with the atmospheric pressure in Denver of approximately 12.2 psia to yield an ECLSS-recommended cabin pressure of 9.0 psia, a value that reflects a 5% control margin.

Of additional concern is the need to ensure that the cabin pressure and corresponding O₂ percentage remain in the unimpaired human performance zone with regard to O₂ hypoxia and toxicity. At a cabin pressure of 9 psia and a 30% O₂ concentration, the atmospheric environment is above the hypoxia level and below the toxicity level. Further, a lower cabin pressure serves to minimize the quantities of O₂ and N₂ required for initial pressurization as well as lowering the prebreathe time required for EVA functions.

Despite the net water generation achieved in the closed water recovery system, three days of potable water should be supplied for contingency purposes and to allow time for the water recovery system to begin generating water.

Impact of the 1-g Environment

Due to the impact of a 1-g environment on fluid pumping systems, consideration will be given to the placement of the ECLSS pumps such that pumping up and/or down will be gravity-assisted.

Components flown at 1-g could be certified in a ground testbed. Alternatively, construction of an appropriate integrated testbed could be performed on the Earth, thereby alleviating the need to fly the equipment for certification purposes for nominal use conditions. However, systems that are needed and couldn't be shutdown during despun operations would still need to be certified for microgravity operations.

After CO₂ reduction is accomplished in the Sabatier, the stream is passed to a phase separator to separate it into a gaseous stream, which is vented overboard, and a liquid stream, which is sent to the OGS. In the presence of Earth-normal gravity, phase separation could theoretically be accomplished with a settling tank. Knowing that the potential exists for limited exposure to a microgravity environment, this is not a likely design specification; rather, the phase separator would be designed with a centrifugal extraction drum inside of it that tilts along the gravity vector in accordance with the gravitational environment.

In general, a fluid system operating in microgravity will also operate under 1-g with no design changes, especially if this potentiality was noted at the time of vehicle design. There are exceptions to this statement; however, if initial consideration is given to how the gravity vector acts on the system, most aspects of the system can be designed to work in Earth-normal gravity. For example, fans or blowers in a 4BMS drive the stream flow and pumps in a fluid system drive the fluid flow, regardless of the gravitational condition. When sizing the fan or pump, the worst-case scenario will be used.

Impact of the Power-rich Environment

Two technologies were evaluated for water recovery, the Biological Water Recovery System (BWRS) and the Vapor Phase Catalytic Ammonia Removal (VPCAR) System. A trade study performed determined that the system using the VPCAR, although more power intensive than the BWRS (6,090 W vs. 2,649 W total system power), was preferable due to its lower mass and volume requirements (1,119 kg vs. 1,596 kg mass and 5.5 m³ vs. 8.0 m³ volume). As previously mentioned, the longer turnaround time of the BWRS as well as the large BWRS expendable mass (2,703 kg vs. 243 kg) are other disadvantages. Therefore, the VPCAR system was recommended for this vehicle.

In analyzing the CO₂ removal system, the technologies of 4-Bed Molecular Sieve (4BMS) and Solid Amine Vapor Desorption (SAVD) were evaluated. Although the 4BMS was slightly more mass intensive than the SAVD (218 kg vs. 111 kg) and larger in volume (0.6 m³ vs. 0.2 m³), its ability to recover H₂O was of value in light of the mission duration. As power is not an issue in the vehicle design, ECLSS elects to use the 4BMS as the CO₂ removal technology. Consideration was given to warm air drying (WAD) and lyophilization (freeze-drying) solid waste disposal options. While the technologies are similar in mass (527 kg vs. 499 kg) and volume (11.2 m³ vs. 11.8 m³), a power comparison demonstrates the more power-intensive nature of the WAD (2,044 W vs. 246 W). Because the technology readiness level (TRL) of the WAD (TRL=8) is expected to remain higher than lyophilization (TRL=5) for the foreseeable future, and based on the longer cycle time of the lyophilization unit, the ECLSS design specifies the WAD technology to process solid waste.

Impact of Operating in a Microgravity Environment for a Limited Duration

Assuming it becomes necessary to operate the ECLSS system in a microgravity environment, certain system modifications, accounted for at the time of initial system design, would be implemented. Atmospheric mixing flow is driven by natural convection while operating under 1-g and would need to be accomplished by an artificial means when operating under microgravity. The use of auxiliary fans that could be switched on at the time of entry into the microgravity environment is one solution to this problem.

Anticipation of the necessity to operate in microgravity for a limited duration would not be problematic in the case of fluid flow, as the specified ECLSS system has been flight-tested in microgravity. The requirement that a system operate in microgravity is a more severe requirement than the requirement for operation in 1-g. Knowing in advance that limited exposure to a microgravity condition is anticipated, the design specification, therefore, includes a flight-tested system.

Although phase separation is easier when gravity-assisted, operation in a microgravity environment is not problematic if the separation unit is designed such that the placement of the internal centrifugal extraction drum can be tilted along the gravity vector in keeping with either gravitational environment.

Impacts of Extending System's Use for 18 to 24 Months

Additional expendables, such as filters and cartridges for the Trace Contaminant Control System (TCCS), will be needed for an extended mission duration.

Extra-Vehicular Activity

Major System Features

The EVA system on the artificial gravity habitat is designed to be used for three planned, two person EVA days per mission. The airlock will transfer two crewmembers per cycle. If full crew transfer is required in LEO, this system assumes all three EVAs are used to transfer crew out of the habitat. EVA days are sized to be 8 hrs, and are accomplished with a PLSS that is sized for eight hours. The system includes a single flexible airlock with umbilical support and PLSS recharge system; no gas reclamation is planned due to the minimal number of EVAs (3). Two EVA tools boxes are provided. Translation aids are provided to aid crew transportation about the vehicle. EVA system spares are also provided. The weights and volumes of the various subsystems are shown in Table 2:

<i>Subsystem</i>	<i>Dry Mass</i>	<i>Volume</i>
Space Suits	690 kg	4.15 m ³
Vehicle Support for EVA	291 kg	0.40 m ³
EVA Translation Aids	123 kg	3.36 m ³
EVA Tools	132 kg	0.20 m ³
Airlock	377 kg	8.18 m ³

Table 2. EVA Subsystem Masses and Volumes.

Functionality

The Space Suit oxygen system is a 3000-psi. gas system. The recharge system used consists of thermal pressurization of cryogenic oxygen from 250-psi to 800-psi and compression by an ORCA to 3000-psi. Since the ORCA cannot accept gas inlets less than around 800-psi, the ECLSS oxygen tank used to provide emergency pressurization is used as a source when the liquid supply source drops below acceptable ORCA inlet pressures. After the PLSS units are refilled, the ORCA is used to pump the ECLSS emergency tank back up to 3000-psi.

Included in the airlock arrangement is a single flexible airlock that allows two persons to egress the AGH at one time. A staging area by the inside airlock door is included in the concept. This area provides volume to store all space suits as well as space suit spares and expendables. Provisions for donning, suit expendables recharge, and checkout are included as well. An unpressurized area by the outside airlock doors is included in the concept. It provides a place for EVA tool storage and allows handling of large objects.

EVA tools provided consist of two toolboxes containing mechanical, electrical, and storage/tie downs. The tools are stowed in the unpressurized area just outside the airlock. EVA system spares as needed to support the six suits and airlock suit recharge provisions are stowed in the AGH in the EVA staging area and remain stored there until needed.

Issues, Challenges, Pros/Cons

The system includes a single flexible airlock with umbilical support and PLSS recharge system; no gas reclamation is planned due to the minimal number of EVAs (3). Operational complexity

and crew time are reduced in this concept. Addition of the depress pump weight (70 kg) and power (1000 W) trades evenly with the mass of air lost at approximately 20+ EVAs. ECLSS considerations for this trade include increased mass, volume, and power of the Oxygen Generation System and increased N₂ tank size to make up lost nitrogen. Each EVA costs approximately 4.5 kg of air (N₂ and O₂ combined).

See also the challenge of reducing system weight described in the next section.

One of the main challenges to the EVA concept is to bring some of the subsystem hardware up to higher TRL levels. One of these subsystems is the airlock. The airlock subsystem items that need technology improvement include the oxygen recharge system that is at TRL 3, and the soft structure (flexible) airlock that is at TRL 3.

PLSS subsystem components will also require further development. The PLSS subsystem items that need technology improvement include the following:

Transvector	TRL 3
Swing Bed CO ₂ & Humidity Removal	TRL 4
High Reliability Pump	TRL 4
H ₂ O Evaporator	TRL 3
Light weight Radiator	TRL 5
Light weight walking suit	TRL 3
Light weight PLSS	TRL 3

Table 3. PLSS Component TRLs.

Impact of the 1-G Environment

Space suits are currently operated in multiple gravity environments, and it is expected that this capability will remain in all future suit designs. The primary technology challenge in this concept is the development of a lightweight suit. Requiring walking and external work in a 1-g environment is one of the more challenging scenarios studied to date. However, in this concept the EVA system design can take advantage of the cold, vacuum environment to utilize some of the more promising lightweight technologies that are currently under development (e.g., Aerogel for insulation, cycling amine scrubbers, permeable membranes). Furthermore, the small number of EVAs also makes existing lightweight technology, such as sublimator cooling and LiOH CO₂ removal, attractive without excessive consumable and stowage requirements for non-regenerable components. On-back carrying weight may also be reduced with rapid on-site recharge of consumables to a shorter duration PLSS or off-loaded onto a consumable pallet.

Impact of the Power-rich Environment

The power-rich environment is no impact to this EVA system concept.

Implications of Operating in a Microgravity Environment for a Limited Duration

Space suits are currently operated in multiple gravity environments, and it is expected that this capability will remain in all future suit designs. As the 1-g environment is the more challenging due to the need to minimize on-back carrying weight and incorporate suit mobility (i.e., walking) features, a contingency microgravity EVA should have no affect on the EVA system operation.

Impacts of Extending System's Use for 18 to 24 Months

Assuming that increasing the mission duration from 18 to 24 months would also add a proportionate numbers of EVAs, only the consumables used by the suits would be affected. Suit quantities and spares would not be affected, as this is a relatively short extension in the service life of the suits. As long as the cumulative number of EVAs stays below 20, the gas reclamation assumption still trades well with regard to the total system mass.

Thermal Control System

Major System Features

For the artificial gravity version of Transhab, the TCS system concept makes use of flexible lightweight body mounted radiators, which are attached to the outer surface. The TCS system has been sized to collect and reject 15.0 kW of heat. Mass, power, and volume are listed below. ITCS refers to coldplates, heat exchangers, and plumbing located inside Transhab, while ETCS refers to similar equipment mounted on the outside. Radiators are listed separately. A more detailed breakdown of equipment mass can be found in the sizing spreadsheet.

	ITCS	ETCS	Radiators		TOTAL
Fluid mass, kg	0.0	34.4	N/A		34.4
Dry mass, kg	111.0	131.0	243.8		485.8
				TOTAL	520.2
Volume, m ³	0.158	0.129	1.742		2.0
Power, kw	0.000	1.109	0.000		1.1

Table 4. TCS Subsystem Summary.

Functionality

A propylene glycol/water coolant is circulated inside the module to collect heat from heat exchangers and coldplates and this heat is rejected to space through the body mounted radiators mounted on the outer shell of the module.

Issues, Challenges, Pros/Cons

A key issue is the ability of body mounted radiators to reject heat during all phases of the mission. To evaluate the capability of the radiators an analysis was performed to characterize the environment in four locations: low earth orbit, a location 0.5 A.U. from the sun, a location 1.5 A.U. from the sun, and Mars orbit. A TSS model was created using Transhab dimensions and estimated surface property values. For each orbit the Assembly was rotated at a speed of 4 rpm in a plane perpendicular to the orbit. The TSS model generates orbital heat fluxes incident on the surface of the module and from these heat fluxes an environmental sink temperature was calculated. The resulting sink temperatures are listed below for the four cases:

Low Earth orbit (220 nm)	201.6 °K (-96.7 °F)
0.5 A.U. Heliocentric orbit	222.1 °K (-59.9 °F)
Mars orbit (220 nm)	163.2 °K (-165.8 °F)
1.5 A.U. Heliocentric orbit	129.0 °K (-227.5 °F)

Table 5. Key Location Sink Temperatures.

These sink temperatures represent orbital average temperatures. To size radiators and to determine the average heat gain or loss from the module orbital average temperatures were used.

The sink temperature results indicate that the warmest environment is the 0.5 A.U. heliocentric or near Venus location, while the coldest temperature occurs at the orbit at 1.5 A. U., which corresponds to the distance of Mars from the Sun. The temperatures also show that on average there will be a net heat loss from the module during all phases. A simple SINDA model was created to determine the average heat leak from the module using the following parameters taken from Transhab design data:

- Shell thickness:** 1 foot
- Shell thermal conductivity:** 0.073 btu/hr/ft °F
- Shell surface area:** 2511 ft²
- Emissivity of outer surface Multi layer insulation:** 0.84
- Effective emissivity of MLI:** 0.05
- Inner wall temperature:** 75 °F

The SINDA model was run with the three sink temperatures above to determine the heat loss through the shell with the following results:

Location	Sink Temperature °K	Heat loss (W)
0.5 A.U.	222.1	2081
Low Earth orbit	201.6	2398
Low Mars orbit	163.2	2788
1.5 A.U.	129.0	2970

Table 6. Habitat Heat Loss at Key Locations.

(Note: ISS Transhab preliminary heat leak estimates were approximately 1.7 kW)

ISS Transhab was planning on blowing air on the inner wall as part of the air circulation system to keep the walls above 60 °F to avoid condensation problems, and analysis results indicated that this method would work with the 1.7 kW heat leak mentioned above. Even with the higher heat leak values anticipated for the Artificial Gravity Habitat in a power-rich environment it shouldn't be a problem to add the required heat to the air to make up the difference. Another design implication of body-mounted radiators is that the radiators themselves will be at a much warmer temperature than the surroundings. This may help to reduce the heat leak on portions of the shell that are covered by the radiators.

Radiator size was determined for the warmest case (0.5 A.U. orbit). The results indicate a required area of 78 m². This represents 51% of the available area of the cylindrical portion of the shell.

Two other sizing exercises were also conducted for the module. The first determined the radiator area needed to reject twice the average load of 15 kW. Assuming the warmest environment temperature at 0.5 A.U., the analysis indicated approximately 157 m² was required. This is just slightly over the total cylindrical area of the shell of 153 m², therefore rejecting just under 30 kw on average is the maximum amount of heat rejection possible without adding something like a heat pump to raise the radiator temperature.

Another sizing exercise determined the heat rejection given the following scenario: The module is in Mars orbit and the crew has left the module for the Martian surface leaving the AG module uninhabited. If the heat loads are reduced and the TCS fluid is allowed to approach its freezing temperature of -50 °C, the question becomes how much heat can be rejected. The analysis

indicated that the radiators could still reject up to 11 kW of heat with the TCS fluid just above its freezing temperature. This is in part due to the much colder environment at the low Mars orbit assumed. At the 0.5 A.U. orbit location heat rejection would be approximately zero because the radiator and sink temperature would be identical for this scenario.

Propylene glycol was selected for the working fluid. The relevant options are water or 60% propylene glycol with 40% water or some other working fluid. While water is non-toxic and has greatest thermal capacity per mass of working fluid, it also freezes at 273.2 K and thus may not allow sufficient radiator availability for some mission phases. 60% propylene glycol with 40% water is also non-toxic but, compared to water, it is a less desirable thermal working fluid. However, 60% propylene glycol with 40% water freezes at roughly 223 K, a significant advantage over water. Thus, tentatively the working fluid for the thermal control fluid loops is 60% propylene glycol with 40% water. As above, complete resolution of this issue also requires in-depth thermal environment modeling focusing on radiant rejection from the habitat.

Impact of the 1-g environment

Pumping losses would increase approximately 10% or 110 watts if the pump was pumping fluid from one end of the habitat to the other against gravity. How the radiators are mounted to the shell in 1-g would also be an issue. It is anticipated that this mounting structure will have to be much more robust than the microgravity attachment method.

Impact of the Power-rich Environment

The extra power available could be used to overcome the anticipated higher heat leak from the habitat by adding heat directly to the air instead of designing a thicker, heavier, better insulating shell.

Implications of Operating in a Microgravity Environment for A Limited Duration

The TCS system concept presented here is similar to most single phase thermal control systems flown on crewed spacecraft to date; hence, no impact is anticipated for operation in microgravity.

Impacts of extending system use from 18 to 24 months

The Artificial Gravity Habitat's TCS uses no consumables so no impacts are anticipated. If the habitat will be traveling to a warmer or colder thermal environment than those considered here, issues may arise that would need to be further explored.

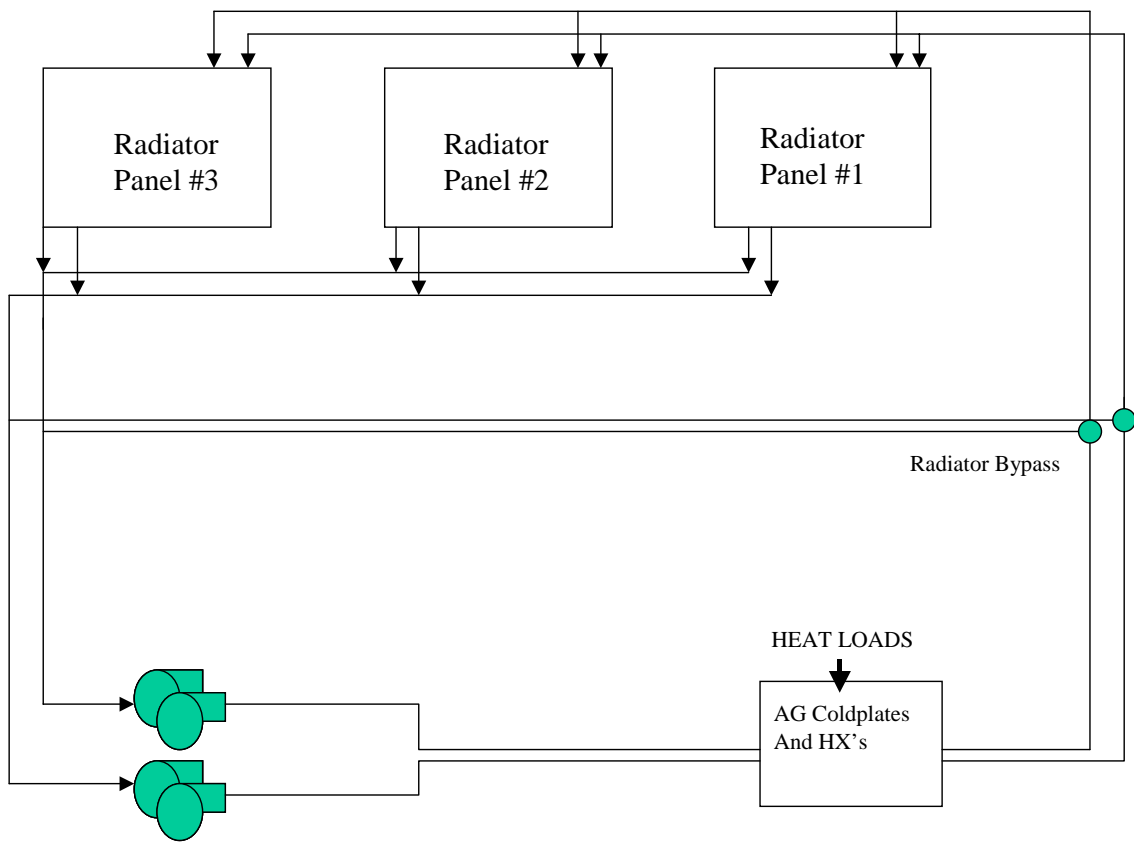

Figure 1. Artificial Gravity Habitat Proposed Thermal Control System Schematic.

Human Factors and Habitability

Major System Features

The Human Factors and Habitability (HF&H) system includes the galley, wardroom, Waste Collection System (WCS), personal hygiene, clothing, recreational equipment, personal stowage, housekeeping, operational supplies, maintenance, and sleep accommodations. Medical operations and exercise equipment are bookkept under Med Ops. Please see Appendix C for internal habitat layout.

For the most part, there will be a reduction of complexity in 1-g habitability systems compared with past microgravity spacecraft systems. For example, WCS, personal hygiene systems, and sinks will not need vacuums to control free-floating debris as in microgravity. Also, the galley can be modeled more closely to an Earth-based kitchen with similar types of appliances and food preparation techniques. In order to minimize the amount of consumables required, a dishwasher, clothes washer, and clothes dryer can be incorporated into the design. An additional feature of this habitat as opposed to traditional spacecraft due to the 1-g environment will be the inclusion of beds, chairs, and other Earth-based comfort items.

The power-rich environment will also permit the consideration of items that are power intensive, yet will help to improve the standard of living onboard the spacecraft. For example, appliances such as incinerators, large freezers, microwave ovens, and convection ovens can now be considered.

For the 18-month mission, the total mass, volume, and power can be seen in Table 5:

Crew Accommodations Subsystem

	Total mass (kg)	Total volume (m ³)	Power (kW)
Crew Habitable Volume	-	101.94	-
Total Galley and Food System	8062.82	31.3499	4.996
Total Wardroom	194.14	6.78	0
Total Waste Collection System	326.52	8.8312	0.0045
Total Personal Hygiene	283.4	4.995	1
Total Clothing	438.2	1.912	0
Total Recreational Equipment & Personal Stowage	150	3	0
Total Housekeeping	215.2	3.612	0.0205
Total Operational Supplies & Restraints	120	0.012	0
Total Maintenance	1091.61	5.906	0.002
Total Sleep Accommodations	120	2.82	0
Total Other Systems	987.117	21.8084	4.1802
Total Crew Accommodations	11989	91.0265	10203.2
	kg	m ³	W

Table 7. HF&H Subsystem Summary.

Functionality

The function of the HF&H system in the artificial gravity habitat is to provide crew accommodations systems and layout to make an 18-month mission habitable for six crewmembers. Functions covered in the artificial gravity habitat HF&H system include the following: crew support (meal preparation, eating, meal clean-up, full-body cleansing, hand/face cleansing, personal hygiene, human waste disposal, training, sleep, private recreation and leisure, small-group recreation and leisure, dressing/undressing, clothing maintenance), and operations (facilities for meetings and teleconferences, planning and scheduling, general housekeeping).

HF&H is also responsible for configuring work and personal stations such that traffic congestions are minimized. Work efficiency, space use, crew comfort, and convenience should be maximized.

Issues, Challenges, Pros/Cons

The main challenge for HF&H is centered around meeting the basic needs of maintaining crew health and performance while minimizing mass and volume.

A balance of reusable, recyclable, and disposable consumables for optimum mass, volume, and crew well-being should be reached.

Other habitability issues include very little opportunity of resupply, required consumables occupying considerable mass and volume, and increased reliability issues due to mission length. The possibility of crew boredom should be addressed since the crew will have limited mass and volume allotments for science and other time- and attention-absorbing work. Psychological effects on the crew should be considered more heavily than in past because of the combination of confinement to a small area, long duration spaceflight, and probable lack of activity.

Food shelf life will need to be extended, as very little space-certified food currently has a 1.5-year shelf life.

One possible way of cutting down on consumables is to incorporate appliances such as washing machines, dryers, and dishwashers into the system design. This will create chores for the crew to keep busy with, use less water, reduce mass of disposable supplies, and could be incorporated into a low-mass washer/dryer/dishwasher combo. However, consideration should be given to the fact that appliances such as the ones listed above use more water than disposable cooking/eating supplies and take up a large non-recoverable mass and volume.

Impact of the 1-g Environment

A 1-g space environment will have more limited options of storage and layout than a microgravity environment. The 1-g habitat will have one defined “down”, toward the floor, whereas in microgravity, all surfaces are possible attachment planes.

Seating and beds, which will occupy considerable amounts of volume, will have to be considered in a space habitat for the first time. As many as 2-4 chairs, stools, or plush seats will be desirable for each crewmember. Efforts should be made to utilize folding and collapsible designs in furniture to maximize space and offer variable space configurations. Also, when choosing bed

materials and designs, incorporation of radiation protection materials into the beds should be considered. A couch will probably be provided for general comfort in the recreational area, and can double as stowage compartments. Bed linens and pillows will be needed for the crew quarters.

Ladders and/or other human/equipment 1-g translation methods between floors must be integrated.

Efficient stowage systems that can bear 1-g loads will have to be devised.

Historically, space food was engineered specifically for microgravity. With 1-g, food can be more like typical Earth-based food in packaging and preparation methods. Most food will need a very long shelf life. Convection will be available to utilize in different elements, especially food-heating.

Vacuums and pumps that were used to control water and waste floating loose in microgravity will not be required for a 1-g environment. This will simplify systems involving liquids, such as the WCS, sinks, and personal hygiene facilities.

General designs of the systems will typically be simplified by the similarity of requirements to their counterparts used on Earth. This will help expedite the flight certification process.

Impact of the Power-rich Environment

A power-rich environment allows new consideration to be made when contemplating options. Incinerators can be considered as possible waste management appliances. Other appliances such as washers, dryers, dishwashers, microwave ovens, conventional ovens, large freezers, etc. can be incorporated. If a power restriction was a major factor in previous designs, new trades can be analyzed on using more power to cut down mass and/or volume.

Implications of Operating in a Microgravity Environment For a Limited Duration

It is anticipated that most systems will be designed to take advantage of the benefits of the nominal 1-g environment. In a temporary microgravity environment these systems may have to be powered down, locked down, and/or safed. Essential systems that must be used within the seven-day limited duration time will have to have designs that allow them to work in a microgravity contingency environment. WCS, sinks, and personal hygiene systems will require pumps and vacuums.

A to-be-determined (TBD) percent of the food will need to be able to be prepared and eaten in microgravity. Procedures and checklists to prepare everything for a microgravity operation will have to be created before the mission and implemented before spin-down.

If the cause of the spin-down is urgent, the crew may not have much time to adapt between the time of spin-down and the time of performing the necessary safing procedures. The crew may not be used to working and operating equipment in a microgravity environment. Due to the quick transition from 1-g to microgravity, movement in the microgravity environment will probably be awkward and design considerations will be need to be made to ease this adjustment (e.g. extra padding on ceilings, longerons in the open, corners, etc.; sufficient handholds; foot restraints in

the floor to maintain nominal orientation; storage systems more typical to past space habitat storage; all cabinets/drawers need to have lock-closed mechanisms).

Impacts of Extending System's Use From 18 to 24 Months

Approximately 33.3% more food mass and volume would be required (2484 kg, 7.56 m³ additional) as well as all other consumables and stowage for those consumables. These additional consumables will be required to have at least a two-year shelf life, which may require additional food technology development.

Appliances and other system components may have more reliability issues due to the extended life requirement.

Medical Operations

Major Systems Features

Model	Mass (Kg)	Volume (m ³)	Power (Watts)
Medical Operations	759.1	3.669 ^{1**}	Primary: 3000W** total ² –20V and 28 V Secondary: Battery supplies for medical instrumentation TBD.
HRF	288.65	2.5	3000W total - 120V and 28V ³
Total	1047.75*	9.175*	6000 *

Table 6. Medical Operations System Summary.

*Total Mass, Power and Volume values assume combined mass of Human Research Facility and Medical Operations capabilities. Determination of Human Research to be conducted during transit is TBD. Merging of Human Research Facility and Medical Operation capabilities will reduce mass and power requirements for transit mission.

** Medical Operation power may be intermittent depending on design. Automated systems will have continuous power draw.

¹Mars Transit Habitat Manifest v. 9001 7/7/99. ²estimated value. ³<http://hrf.jsc.nasa.gov/rack1.htm>

Functionality

The medical operation capabilities onboard the artificial gravity habitat during transit will provide medical contingencies to promote successful mission completion, crew health, safety, and optimal crew performance.

The potential medical contingencies that are to be addressed while living within the artificial gravity habitat during space exploration include those currently required for International Space Station and additional procedures unique to a continuously rotating spacecraft. Following the convention for classification of medical contingencies onboard ISS, the artificial gravity habitat will enable the practice of emergency medicine, environmental medicine, countermeasures or preventive medicine, rehabilitation, and dentistry. Emergency medical procedures will provide for Advanced Cardiac Life Support (ACLS), Basic Cardiac Life Support (BCLS), and trauma. Additionally, emergency medical contingencies may include shock, behavioral, compromised airway or breathing, drug overdose, and smoke inhalation. Environmental medicine will enable treatment for exposure to toxic and hazardous materials. Countermeasures/Preventive Medicine and Rehabilitation will enable countermeasures to prevent neurovestibular dysfunction resulting from the Coriolis effect induced by the rate of rotation of the spacecraft. Coriolis effects induced by rotation of the spacecraft develop within the neurovestibular system and impacts motor performance, behavior, and motion sickness. Exposure to partial gravity, 0.38G, may greatly impact musculoskeletal and cardiopulmonary systems. If the exploration mission includes habitation of Mars, then the artificial gravity habitat medical operations system will implement countermeasures to physiological adaptation to Martian gravity during transit return to Earth.

Dentistry onboard the artificial gravity habitat will enable basic cleaning, crown replacement and treatment of exposed pulp.

The artificial gravity habitat medical operations system will include remote monitoring, data acquisition, analysis, and interpretation such that collection of medical data and implementation of medical protocols will minimize crew intervention. Feasible reduction of crew intervention will promote effective management of crew time during daily operations, robust capacity for implementation of medical instruments during emergency, and greater logistical flexibility during the scheduling of crew tasks over the duration of an extended exploration mission. Monitoring capabilities will enable assessment of motor control, psychological and performance measurements unique to potential neurovestibular dysfunction. The human neurovestibular system enables humans to balance and to physically orientate themselves with their environment. Neurovestibular dysfunction such as in-flight disorientation, space motion sickness and postlanding vertigo and locomotion problems may potentially occur as a result of significant artificial gravity gradient inherent to the artificial gravity habitation module. The artificial gravity gradient will be dependent upon the span of the spacecraft and the spacecraft's rate of rotation. Also, monitoring capabilities will include radiology equipment for imaging of tissues and organs to permit diagnosis of trauma or illness for determination of treatment strategy.

The collection and distribution of medical data onboard the AG Habitat will require distributed computing capabilities, which handle characteristics unique to medical data. Distributed computing architectures provide the ability to access and execute software from all user-terminals. The ability to access specialized software and information databases from any user terminal provides ease of access that may benefit logistics during daily operations and emergencies. Ubiquitous accessibility of software and databases may reduce the number and the resulting collective mass of required user terminals. Data unique to medical operations may include securing privacy of medical data and file sizes of medical images. Distribution of medical data will enable teleradiology, the transfer of radiological data via telemetry for diagnostic purposes.

Delivery of medical treatment onboard the AG Habitat will provide decision assist technologies to facilitate the provision of reliable medical care. Acknowledging a 5-20 minute lag-time for communications between Earth and Mars, the implementation of predictive clinical algorithms will assist crewmembers during the planning and implementation of medical care in the delay or absence of directions from ground support via Mission Control.

Issues, Challenges, Pros/ Cons

Current literature review of neurovestibular and resulting physiological system response to varying rotational rates is limited. Findings of experimental studies offer conflicting conclusions regarding the rotational rate humans may be subjected to without compromising performance, psychology and physical health.

Current research onboard ISS, specifically experiment 044 –Pulmonary Function in-flight addresses structural changes within the cardiopulmonary system that may lead to altered kinetics of gaseous (i.e., oxygen, carbon dioxide, nitrogen) exchange and resulting complications for crew health and safety. Similarly, the extended habitation within a gravity environment, i.e. 0.9G-1.1G may induce structural changes which produce altered respiration rates and kinetics of gaseous exchange. Specifically, if the exploration mission included habitation of Mars, then the transit

vehicle would provide for countermeasures and therapy of cardiopulmonary adaptation to the 0.38, partial gravity of Mars.

The variable communication time of 5-20 minutes between Earth and Mars suggests autonomous, intelligent systems may be required to enable crew management of emergency scenarios, especially medical emergencies. Acknowledging brain damage then failure occurs during a period of 5-12 minutes without oxygen, a communication delay between Earth and the habitation module may critically impact crew safety and health.

Artificial gravity imposed by a rotating spacecraft enables the crews to exercise Advance Cardiac Life Support and Basic Life Support via conventional 1-g protocols (i.e. intubation, spine boarding, cervical spine immobilization). Secondly, any pharmacological production enabled onboard the habitation module may produce drug mixtures and purification via conventional 1-g protocols.

One of the major anticipated benefits of this spacecraft is that the musculoskeletal countermeasures will be minimized during transit to Mars as a result of the constant 1-g artificial gravity environment. Additionally, if a Mars surface mission were to take place after the 1-g outbound transit phase, reintroduction problems to the surface's gravity environment may be completely eliminated, which would most likely be present if the crew were subjected to a microgravity outbound transit phase. Finally, the artificial gravity environment will provide hydrostatic pressure within the body tissues and cells.

Specific Challenges

To determine a range of revolutions per minute suitable for human habitation, safety, and optimal performance. Literature reviews propose various maximum rates of rotation for Artificial Gravity spacecraft suitable for human habitation during extended duration missions. Further investigation to clarify conflicting research is required to conclusively propose acceptable rates of rotation and the resulting spacecraft length. Human performance under environments of significantly varying gravitational fields, (i.e. 1.1G – 0.9G along the length of the habitation module) has not been studied sufficiently to conclusively interpret results nor utilize in a predictive manner. The initial assumptions of vehicle design (4 RPM, 100 m length) should remain open to review and change pending conclusive determination of human adaptation and response to varying gravitational fields with respect to time.

To develop and implement an intelligent medical system. The need for an intelligent medical system results from the benefits of crew performance and management of operations. The capability to collect biosignals for monitoring of crew health and safety in a manner transparent to daily operations reduces the number of tasks to be performed daily and during moments of crisis. The orderly and coordinated collection of these biosignals may serve both medical operations and human research during such human exploration of space.

To develop and implement a distributed computer system architecture. The benefit of distributed computing is to provide access to all software programs from any user-terminal. Consequently, the number of user-terminals is reduced providing for successful operations with a minimal number of user terminals. The provision of distributed computing permits treatment and stabilization of crewmembers located at a distance from the medical operations suite.

To develop an internal habitat architecture suitable for transfer of injured crew. The method for transferring injured crewmembers between different levels of the artificial gravity habitat during both micro-g and 1-g environments will need to be incorporated into the internal architecture of the habitat module. The ability to transfer patients via ladder systems presents challenges that may be addressed by designing adaptable/reconfigurable portals to support limited ambulatory abilities and the mass of crewmembers with required supporting medical equipment.

Impact of the 1-g Environment

There are no impacts anticipated to provision of medical equipment, including the countermeasure equipment. If the transit vehicle design includes provisions for the crew after a Mars surface mission, then the medical operations system will potentially include rehabilitation for crewmembers during transit to Earth.

Artificial gravity imposed by a rotating spacecraft enables the crews to exercise Advance Cardiac Life Support and Basic Life Support via conventional 1-g protocols (i.e. intubation, spine boarding, cervical spine immobilization). Secondly, any pharmacological production enabled onboard the habitation module may produce drug mixtures and purification via conventional 1-g protocols, i.e. I.V. solution.

Impact of the Power-rich Environment

Medical operations may significantly benefit from a power-rich environment by including power-intensive medical equipment, bioinstrumentation and telecommunication capabilities. Extended duration space missions may include greater diagnostic and surgical capabilities. The ability to collect a greater number measurements and a larger total amount of biomedical data will require electronic databases and telecommunication capabilities to transmit these data. The implementation of intelligent computer systems requires continuous deployment of software intensive operations. Hence, power draw from Medical Operations may be continuous to implement continuous monitoring of crew health and safety. Examples of benefits for Medical operations employed under a power rich environment could be the following:

- X-ray capabilities may be implemented for imaging of potential bone fractures.
- Bone-densitometry may be implemented to monitor bone strength during mission duration and adaptation during spaceflight.
- Laser technology may be implemented for cauterizing wounds or opening of wounds during surgical procedures.
- Computer aided surgery technology for performance of fine surgical procedures and countermeasure for motor controls deficits that may potentially be incurred during Artificial Gravity environment.
- Virtual reality training systems to maintain and/or learn clinical skills during extended duration space missions.
- Ultrasound treatment of bone stress fractures.
- Countermeasure/ exercise equipment with biofeedback dynamometers to maximize workload efficiency for predetermined purposes (strength/cardiovascular conditioning, stress tests, rehabilitation) for scheduled time period.
- Remote monitoring of biosignals via infrasonic technology.

Implications of Operating in a Microgravity Environment for A Limited Duration

Medical operations in micro-g will provide equipment and restraints for stabilization of the patient and practitioner to facilitate spine boarding, cervical spine immobilization, intubation and other gravity assisted operations.

Periods of microgravity may induce subsequent bouts of motion sickness and re-adaptation. Hence, arresting rotation of the artificial gravity spacecraft during habitation may induce subsequent episodes of motion sickness and impact performance.

Periods of microgravity will prevent cooling off medical operation instrumentation via convection.

Periods of microgravity will require user-interface design compatible with both 1-g and micro-g mobility.

Impacts of Extending System's Use from 18-24 Months

Spaceflight missions of greater duration inherently require measures to insure crew health and safety resulting from any physiological adaptation to the environment for a designated duration and a greater amount of consumables. Medical operations will be impacted by extending mission duration six months, from 18 months to 24 months, by a prudent need to re-evaluate operations and space medicine research for applicability to mission duration of 24 months. Current space medical research of artificial gravity inhabitants does not provide basic constructs to project health, performance and behavior in such an environment during 18 months exposure nor 24 months exposure. However, some literature may suggest artificial gravity environments could potentially enable planetary travel without dangerous physiological adaptation. A 25% increase of mission duration may increase the mass and volume of medical operation consumables equally. The resulting total mass and volume of these consumables extrapolated from the Mars Transit Habitat Manifest v. 9001 is 14.25 Kg and 0.1125m³. The corresponding total mass and volume of Medical Operations changes from 759.1Kg to 773.35 Kg and from 3.669m³ to 3.781m³. Extended mission duration will not significantly impact the power requirements of medical operations. Given current medical operation onboard ISS require intermittent power supply and represent a limited amount of power expended onboard ISS, the power requirements of medical operations for a planetary transit mission may be significant based upon the chosen strategy and design of medical operations. Hence, the implementation of an intelligent medical system will require continuous power draw, rather than intermittent to perform system evaluations, continuous monitoring and communications with ground support. However, this power draw is independent of time and should not impact power requirements if mission duration were extended six months.

Structures and Mechanisms

Major System Features

The major system features of the structures and mechanisms are represented in the current concept for the ISS TransHab, only modified to account for the changes in operating environment (artificial gravity and deep space). The configuration under study consists of a pressurized habitat module, an airlock, and an adapter (possibly integral to the core structure itself) to attach it to the spacecraft truss section.

Element	Mass (kg)
Unpressurized End cone	650
Pressurized End cone	800
Internal fixed structure	2,120
Internal deployable structure	1,870
Outer Shell	6,000
Crew Quarters Radiation Insulation	1,500
Total weight of the structures	12940

Table 9. Structures and Mechanisms Masses.

The mass of the core and load-bearing structures was determined using the input received during the first AGH Project Peer Review. Compared with the TransHab core structure, the AGH core and load-bearing structures will see an increase in mass due to the additional support required in 1-g. Furthermore, the outer shell may increase in mass too if more layers of MMOD or insulation are added to meet the radiation shielding effectiveness level required to ensure the safety of the crew in deep space. Finally, the AGH outfitting mass is to be determined also on the basis of the various systems and sub-systems requirements.

Functionality

The structure and shell are to provide a safe habitat for the crew and the necessary space to store supplies and equipment to sustain them for the duration of the entire mission. The inflatable module design was chosen because it is the best means to effectively increase the habitable volume of a spacecraft while keeping the diameter of the core within acceptable payload size limits set by current launch vehicles. The airlock system is to provide the crew with the capability to perform extravehicular activities. It is to be located atop the habitat module, so as to allow the fully suited EVA astronauts to take advantage of a slightly lower gravitational pull. The bus system is to raise the fully outfitted Hab to a higher orbit, assuming the final assembly of the spacecraft and activation of the nuclear power plant does not take place in LEO, but at a higher orbital altitude.

Issues, Challenges, Pros/Cons

The prevailing issue remains the considerable addition of payload acting on the load-bearing structure. The original concept of the TransHab had a structure suitable for launch, then reconfigured significantly to operate only in microgravity. With the use of a TransHab module in a 1-g environment, the problem arises as to the ability and suitability of the AGH structure not only to support itself, but also its payload over the course of multiple deep space missions.

To underline the fundamental aspect of the problem, one must carefully address the issues of moving a maximum of payload to the outer perimeter of the spacecraft to protect the crew from radiation, and that of safeguarding the integrity of the core structure by keeping as much payload near the center of the spacecraft as possible.

Compounding the problem is the absolute necessity to keep the shell free of any interference or contact with the inner structure. For all intent and purposes, the shell is to be regarded as isolated from the rest of the habitat.

While the inner wall of the shell itself should remain unaffected by the 1-g acceleration, the outer layers will undoubtedly sag outward, thereby compressing the outer shell and reducing the amount of MMOD and radiation protection towards the top of the module.

Impact of the 1-g Environment

As discussed above, the first impact of introducing gravity is the necessity to modify the core structure by re-designing it into a load-bearing structure, hence adding a lot more mass. The original TransHab concept contained cloth flooring with inflatable supports, which would be woefully insufficient in a 1-g environment.

The introduction of a 1-g environment also introduces the hazards of slips, trips, falls, and falling objects. Pathways, ladders, floor cutouts, crew quarters, the kitchen and ward room will all have to have some measure of protection. Even a mild injury on a transit flight to Mars is a very serious matter. The potential for objects falling on the floor, or even farther down below, calls for reinforcement of the floor and the inner, bottom surface of the inflatable shell if deemed necessary.

A winch system may be considered necessary for the vehicle to allow for the maneuvering of heavy objects from one floor to another. There may be a need to move a crewmember from one floor to another should he/she be unable to use the ladder system.

Impact of the Power-rich Environment

The power-rich environment will probably entice the design team to consider power-hungry systems and sub-systems possibly at the expense of both mass and volume (although this was shown not to always be the case). It may also entice system leads to include extra hardware and appliances that were not considered feasible in the past. To that end, and in light of the limited volume available, it would be desirable to discriminate between what can be safely installed or stowed outside, and what is absolutely necessary to keep inside.

Implications of Operating in a Microgravity Environment For a Limited Duration

Operating in a microgravity environment will be necessary for the outfitting (cargo deployment, installation and stowage) of the vehicle. Outfitting of the vehicle with large, cumbersome, heavy racks and supply pallets would indeed be extremely difficult in 1-g.

Impacts of Extending System's Use From 18 to 24 Months

The extension of the mission will cause for the need of more supplies. The added mass to the vehicle will increase the needed support structure for the vehicle.

Electrical Power System

Major System Features

The electrical power system for the Artificial Gravity Habitat consists of three main subsystems: 1) Secondary Power, 2)Wiring, 3) Power Management and Distribution. These three subsystems can be further broken down to the component level as can be seen in the following table:

	Volume (m ³)	Mass (kg)	Quantity
Secondary Power			
Fiber Li-Ion Battery	0.17	335	1
Battery Charge/Discharge Unit	0.09	50	3
Wiring			
Main Bus Cable	0.84	7.5	3
Jumper Cables	0.42	4.5	24
Secondary Power Distribution Cables	0.0001	0.213	816
Wiring Harness Secondary Support Structure	3.80	91	1
Power Management and Distribution			
Galaxy Inverter Boxes	0.04	28	3
Custom Built 400 Hz, 115 Vac RPC Box	0.04	20	12
Kilovac Relays	0.001	2	45
Unitron PS-95-448-1 400 Hz to 60 Hz Frequency Converter	0.04	21.4	9
Vikor AC/DC Rectifiers	0.0007	2	9
Totals	18	1505.2	

Table 10. Electrical Power Subsystem Masses and Volumes.

Functionality

A few assumptions about the type of primary power routed to the habitat were made in order to develop a baseline electrical power system. The assumption was made that the power entering the habitat would be 115 Vac, delivered at 400 Hz. As the architecture currently stands, aside from the habitat, the other major power consumer on the Artificial Gravity Transit Vehicle is the electrical propulsion system. Although the architecture has not yet been completely defined, it seemed that 115 Vac at 400 Hz was a reasonable assumption for the type of power the electrical propulsion system may use. This assumption also seemed reasonable for the type of power that would be useful for the system components within the habitat. A final assumption that was made was that the habitat would nominally use 15 kW of power. An initial estimate assumed that the habitat would consume 12.5 kW of power based on the nominal power usage of similar elements in two different studies: the Earth's Neighborhood Gateway element and the 1999 Mars transit vehicle. This original assumption was increased to 15 kW based on results from the first peer review session for the Artificial Gravity Habitat.

With these assumptions in mind, the Power Management and Distribution (PMAD) subsystem components could be chosen. Three types of power were chosen that seemed like they would be useful within the crew cabin. The first type was 115 Vac power at 400 Hz. In order to distribute this power, 115 Vac 400 Hz Remote Power Controllers (RPCs) were incorporated into the PMAD subsystem. From these RPCs 115 Vac 400 Hz power could be supplied to a variety of system components. A second type of power that was chosen for use within the crew cabin was 115 Vac operating at 60 Hz. This was chosen, since it would allow for many of the system components to be purchased as Commercial Off the Shelf (COTS) items. This will help to reduce development time and costs for the other systems. In order to enable 60 Hz power to be available, 400 Hz to 60 Hz frequency converters were chosen. Each of these converters has six outlets and can supply ~3 kW of power. Finally, the third type of power chosen for use within the habitat was 28 Vdc power. This power rectification required the use of AC/DC power rectifiers. These rectifiers will be able to supply racks within the habitat with 28 Vdc power and a few were accounted for to allow 28 Vdc power to be supplied to visiting vehicles, if this ever enters the architecture.

The wiring system was sized based on Transhab data and results from the Gateway study. The mass and volume of the components within the wiring system were sized based on power requirements and the size of this habitat.

The final subsystem that needed to be sized for this habitat was the secondary power source. Upon analyzing the architecture and the type of primary power sources, a decision was made to supply 24 hours of emergency power to the habitat that will accommodate 50% of the nominal load (180 kW-h). Based on the architecture, it was felt that if the primary power sources were to fail, this would result in the loss of the crew and loss of the mission. Since there would be no way to rescue the crew during the long transit portions of the mission (months at a time) if the primary power sources were to fail, it would be unreasonable for a secondary power source to be expected to supply sufficient power for such long periods of time. It was also assumed that two nuclear power sources, each with dual fault tolerance, would be available to supply the power to the propulsion system and the habitat. Therefore, the emergency power was designed with the intent that it would only be used if both primary power sources needed to be shutdown for a period of time due to a problem not related to the reactors themselves. Fiber Li-Ion batteries were chosen for the secondary power source due to their high energy densities and duality of use as structural or habitability components within the crew cabin.

Issues, Challenges, Pros/Cons

Most of the Electrical Power System components are fairly common COTS items. However, two items will need further development. The first is the 400 Hz RPCs. These are currently under development and are at about TRL 6. The second item that needs further development is the fiber Li-Ion battery. Currently, these are a DARPA project and are at about a TRL of 2.

A trade that should be considered more carefully is the frequency at which the primary power source will be operating. An assumption was made that it would operate at 400 Hz. This was driven by the fact that systems that operate at 400 Hz are generally significantly less massive than ones that operate at 60 Hz. Therefore, choosing 400 Hz was extremely beneficial from a mass savings point of view. However, traditional spacecraft components have been designed to operate on DC power. Also, many of the common COTS items operate on 60 Hz. Therefore, the extent to which system components would have to be redesigned to operate at 400 Hz should be carefully considered.

Impact of the 1-g Environment

It is not believed that the 1 g environment will have any significant impacts on the power system design. The only item that may be affected is the method of cooling. Operation in a 1-g environment may now allow for a limited amount of convection cooling to be used for maintaining system component temperature limits. However, this design decision has other implications, which are noted in the “Implications of Operating in a Microgravity Environment For a Limited Duration.”

Impact of the Power-rich Environment

The fact that the habitat will be operating in a power rich environment, will drive system leads to design systems that are more power hungry than those used in traditional spacecraft. This will impact the magnitude of power this system must distribute. This may lead to increased mass as a result of more or heavier duty PMAD system components so that the increased power distribution can be handled. It may also require that more mass and volume are allotted to the Wiring subsystem to accommodate the extra loads.

Implications of Operating in a Microgravity Environment For a Limited Duration

The only two minor concerns of operating in a microgravity environment include selecting an appropriate cooling method and securing all system components down to a surface in the event that the vehicle is de-spun.

Traditionally, cooling electrical components in spacecraft has been done through the use of coldplates. Since this habitat will be operating in a 1-g environment, maintaining component temperature limits through the use of convection cooling may become an option. However, it is recommended that the system be designed such that the coldplates are capable of performing the cooling task without the help of convection cooling in the event of a required microgravity operation. Instead, convection cooling could be used as a means above and beyond the required capabilities.

It will also be necessary to secure all system components down to a surface. This will be necessary in the event of a required microgravity operation. If the components weren't satisfactorily secured, the electrical components could pose a significant risk to the crew.

Impacts of Extending System's Use from 18 to 24 Months

The only way in which extending the electrical power system's use from 18 to 24 months could be an impact is in the system's reliability over an extra six month period. Although, it is not believed that this will be a problem, it should be examined by a qualified reliability expert.

Conclusions

In this study, four “Big Questions” were asked:

- What are the impacts to system designs, compared to traditional spacecraft, of operating in a 1-g environment?
- What are the impacts to system designs, compared to traditional spacecraft, of operating in a power-rich environment?
- What would the impacts be to system designs if the spacecraft were required to operate in a micro-g environment for a duration of up to 7 days?
- What would be the impact of extending the systems’ use from 18 to 24 months?

Each one of these questions was considered by the system leads who provided inputs for their respective systems. The following is a summary of these inputs.

Impacts of Operating in a 1-g Environment

The reason for exploring a 1-g artificial gravity transit vehicle is its perceived physiological benefits. Despite the uncertainties regarding neurovestibular adaptation to a rotating spacecraft, it was felt by the medical operations community that a 1-g artificial gravity environment could potentially solve some of the major hazards presented in the Critical Path Roadmap (CPR) Baseline Document. Some of the main hazards that may be solved include bone loss, cardiovascular alterations, and muscular alterations/atrophy.

It was also noted by many of the system leads that the 1-g operating environment would allow them to model their systems after Earth-based analogs. For example, the medical operations community would be able to use standard 1-g protocol for advanced cardiac life support, basic life support, and pharmacological production. Likewise, the Human Factors and Habitability (HF&H) community would be able to provide similar appliances and prepare food in the same fashion that would be used on Earth. A similar input by system leads was that the systems could largely be certified in Earth-based testbeds, except for protecting against the short duration micro-g contingency. This capability would largely decrease costs of hardware certification and cheaply improve system reliabilities.

Another point that was brought up by system leads was the fact that many of the systems may be able to be simplified when compared to those of traditional spacecraft. For example, the Thermal Control System (TCS) and Environmental Control and Life Support System (ECLSS) may be able to use convective cooling rather than coldplates for hardware components. This would decrease system complexity and, most likely, improve system reliability. Similarly, fluid systems in general could be simplified. Those open to the crew cabin would no longer require vacuum pumps to keep debris and fluids from floating out into the habitat. Closed fluid systems in which phase separation is required would no longer need centrifugal extraction drums; instead, they would rely upon the induced gravity vector to perform this function. Eliminating hardware such as this would also contribute to increasing system reliabilities.

One of the main topics that the Advanced Design Team wanted to understand with regard to operating in a 1-g environment was the negative impact that it had on the habitat. At this level of system fidelity, no show-stoppers were identified, yet there are a few items worth noting. After examining the system leads’ data, it was found that a few systems took a mass-hit in order to

accommodate the 1-g loading. Most notable were the structures group (~1900 kg) and the HF&H group (~580 kg). Other systems were able to either slightly modify their systems relative to traditional spacecraft to either compensate or take advantage of the 1-g environment. Systems such as TCS, ECLSS, and HF&H were required to use slightly larger pumps (~10%) in order to pump fluids from one end of the habitat to the other. The TCS and ECLSS systems will largely be able to rely upon natural convective cooling during 1-g operations, which will help to reduce system complexity and improve system reliability.

Impacts of Operating in a Power-rich Environment

The fact that this spacecraft will be power-rich, puts it in a unique position when compared to that of traditional human-rated spacecraft. Three categories of benefits were found in this study, which can be attributed to the power-rich environment:

- System leads were often able to trade power consumption for components with a smaller mass and volume
- On-board capabilities were able to be enhanced
- Extra comfort could be afforded for the crew.

From the habitat's point of view, the power-rich environment presented only one area where design considerations would have to be made: thermal rejection.

As stated previously, one of the main benefits of the power-rich environment was that system leads were able to trade power consumption for components with a smaller mass and volume. Two examples of this sort of trade-off were used by the ECLSS system leads. When the system leads were examining options for the water recovery system, two choices presented themselves. The first option was to use the Vapor Phase Catalytic Ammonia Recovery (VPCAR) unit (6 kW, 1119 kg, 3.95 m³) or a Biological Water Recovery System (BWRS) unit (2.6 kW, 1596 kg, 8 m³). If this were a traditional spacecraft, the ECLSS leads would have perhaps opted for the BWRS due to its significant power savings. However, the unique power-rich environment of this spacecraft allowed them to pick the VPCAR, which is more power-intensive, in order to save mass and volume. This sort of trade was also made in the waste management subsystem. The ECLSS leads were once again faced with two main options: a Warm Air Dryer (WAD) (2 kW, 129 kg, .4m³) or a Lyophilization unit (.25 kW, 125 kg, 1.4 m³). Although they had roughly the same mass, the volume of the WAD allowed a significant volume savings. Therefore, once again, the trade for power-consumption vs. volume savings was made.

The second benefit of the power-rich environment that surfaced in this study was the fact that it allowed for enhanced on-board capabilities. Several systems were able to take advantage of the extra power in order to improve their systems. For example, the medical operations group was able to allow power-intensive devices that enabled a "Stand and Fight" philosophy (x-ray machines, ultrasound units, computer aided surgery devices, virtual reality training systems, etc...). The ECLSS leads also found that they were able to enhance their system by choosing a 4-Bed Molecular Sieve (4BMS) over the Solid Amine Vapor Desorption (SAVD) system. Although the 4BMS had a greater power, mass, and volume requirement ((734 W, 218 kg, .6 m³) vs. (156 W, 111 kg, .2 m³)), its capability to recover H₂O was significantly better than the SAVD. Avionics was another group that identified potential improvements to their system's performance. They noted that increased power allowances would allow them to send stronger signals from the spacecraft, which would allow them to decrease pointing requirements and increase data

transmission rates. Finally, it was found that nearly all system reliabilities could be improved, since extra power would allow for redundancy in computation capabilities and instrumentation.

The final major benefit identified by the system leads due to the power-rich environment was the extra comfort afforded for the crew during the missions. Items such as freezers were added such that a diet of 1/4 to 1/3 frozen food can be supported. Additional items such as a washer/dryer, dishwasher, microwave, convection oven, TV, computers, etc... were also added in order to improve the standard of living on-board the spacecraft.

Implications of Operating in a Microgravity Environment for a Limited Duration

The microgravity contingency scenario that was used for analysis during this phase of the study was found to have both technical and operational implications. However, it was felt that with appropriate design consideration and operational planning, the habitat would be able to accommodate operating in a microgravity environment for the seven-day specified duration.

The systems that were most affected by the microgravity environment were the fluid systems. It was noted that the fluid systems that are open to the crew cabin (WCS, sinks, personal hygiene systems, etc...) would require vacuum pumps to prevent debris and liquid from entering the habitable volume. Secondly, fluid systems that required separation of gases from liquids would require centrifugal extraction drums to be added to the system design.

It was also noted that the TCS and ECLSS systems would be required to provide the means for thermal collection during a microgravity scenario. If the thermal collection method were designed around the use of natural convection, either hardware to allow forced convection or coldplates would need to be used.

If the habitat were required to operate in microgravity for a short duration, a small amount of food would have to be provided to accommodate micro-g consumption. This means that a certain portion of the allotted food for the mission would need to be packaged in small, single person serving sized containers.

Finally, it was found that procedures would be required for switching over from a 1-g operating environment to a micro-g environment. It is envisioned that these procedures would outline the process of switching systems over for micro-g operation and stowing/fastening down all loose items in the crew quarters. These procedures would have to be pre-planned and the crew would need to be given time to perform the required tasks.

Impacts of Extending Systems' Use from 18 to 24 Months

The main impact of extending the systems' use for six months was found to be the mass and volume of food and habitability supplies that would be required for this extra duration. It was estimated that an extra six months would add as much as 3000 kg extra mass and up to 18 m³ of food and habitability supplies. Due to this extra mass, a TBD amount of extra support structure would be required.

A second observation was that the radiation shielding would also need to be increased in order to keep absorbed doses within desired limitations. Currently the habitat has added 1500 kg of extra mass, most likely water or polyethylene, in order to provide supplemental radiation protection. If

the mission duration were increased by six months, a TBD extra mass should be expected for extra shielding.

Much more minor mass hits were also noted by some of the system leads in order to accommodate this extra duration. For example, ECLSS would be required to carry extra filters and cartridges for the Trace Contaminant Control System. ECLSS would also be required to store extra gases in order to accommodate leakage of habitat over this longer duration and possibly extra cycles of the airlock. ECLSS leads also found that they would need a larger storage tank in order to accommodate the extra waste associated the extra duration. The Medical Operations group also indicated that they would need more consumables in order to deal with shelf lives of Limited Life Items (LLI).

The final impact of extending the systems' use from 18 to 24 months was the fact that system reliabilities would have to be assessed while taking the longer duration mission into account. Since reliability is a function of mission duration, it should be expected that either a greater number of redundancies or more reliable hardware would be required in order to meet desired reliability standards.

Future Work

Throughout the course of this study, a few items were identified that should be examined more closely in the future. It is felt that there are both individual system lead research projects as well as integrated design environment activities that could be done in order to enhance the data generated during this phase of the study.

One of the first tasks that would help all parts of the design would be to develop a more defined operations concept. Items such as vehicle orientation, thermal environment, vehicle assembly scenario, required capabilities during contingency situations, etc... would be helpful to understand. These types of high-level operational assumptions would be pertinent to all system designs.

One of the major trades that should be examined more closely is the body-type of the habitation module. For this design phase, the Transhab module was chosen as a reference habitat. However, due to its configuration, internal structural design, and design for microgravity operating environment, it was felt that there may be more optimal variations of inflatable modules that could be used. For several reasons (ie. simplicity, ease of outfitting, support during 1-g loading, habitable volume requirements, etc.), it was felt that a hardshell module may prove to be the most appropriate design option.

It was also felt that the idea of designing to a particular habitable volume should be reexamined. Although habitable volume is a very logical specification to define for a traditional spacecraft, the fact that this habitat will operate in a 1-g environment completely changes the rules. Since this habitat is more analogous to an Earth-based house or apartment rather than a traditional spacecraft due to the 1-g environment, it is felt that efforts should be made to determine an appropriate habitable floor area rather than define a habitable volume.

It would also be beneficial to conduct a second phase of integrated design team activities. A second phase would allow the system leads to explore a greater variety of system trades in greater detail. A few of the larger future system level trades that were identified in this study include the following:

- Convection cooling vs. coldplating
- Type and frequency of power supplied to systems
- Feasibility of emergency power
- Percent closure of ECLSS systems
- Antennae type and placement
- Placement of EVA systems
- Ingress/egress location and method

It would also allow system leads to develop more refined system designs, which would yield more detailed system estimates for mass, power, and volume. A second phase would also allow products such as system reliability data, radiation analyses, and power profiles to be generated. Finally, it would allow more time to explore the implications of operating in a microgravity environment for a limited duration, assess sensitivities associated with mission duration, and identify the positive/negative aspects of operating in a 1-g, power-rich environment.

Appendix A – Acronyms

ACLS	Advanced Cardiac Life Support
AG	Artificial Gravity
AGH	Artificial Gravity Habitat
BCLS	Basic Cardiac Life Support
BWRS	Biological Water Recovery System
COTS	Commercial Off the Shelf
DARPA	Defense Advanced Research Projects Agency
ECLSS	Environmental Control and Life Support System
ETCS	External Thermal Control System
EVA	Extra-Vehicular Activity
4BMS	4-Bed Molecular Sieve
HF&H	Human Factors and Habitability
ISS	International Space Station
ITCS	Internal Thermal Control System
LEO	Low Earth Orbit
LLI	Limited Life Items
MMOD	Micro Meteoroid and Orbital Debris
PLSS	Personal Life Support System
PMAD	Power Management and Distribution
RCRS	Regenerative CO ₂ Removal System
RPC	Remote Power Controller
RPM	Rotations Per Minute
SAVD	Solid Amine Vapor Desorption
TBD	To Be Determined
TCS	Thermal Control System
TRL	Technology Readiness Level
VPCAR	Vapor Phase Catalytic Ammonia Recovery
WAD	Warm Air Dryer
WCS	Waste Collection System
WMS	Water Management Subsystem

Appendix B – ECLSS System Diagram

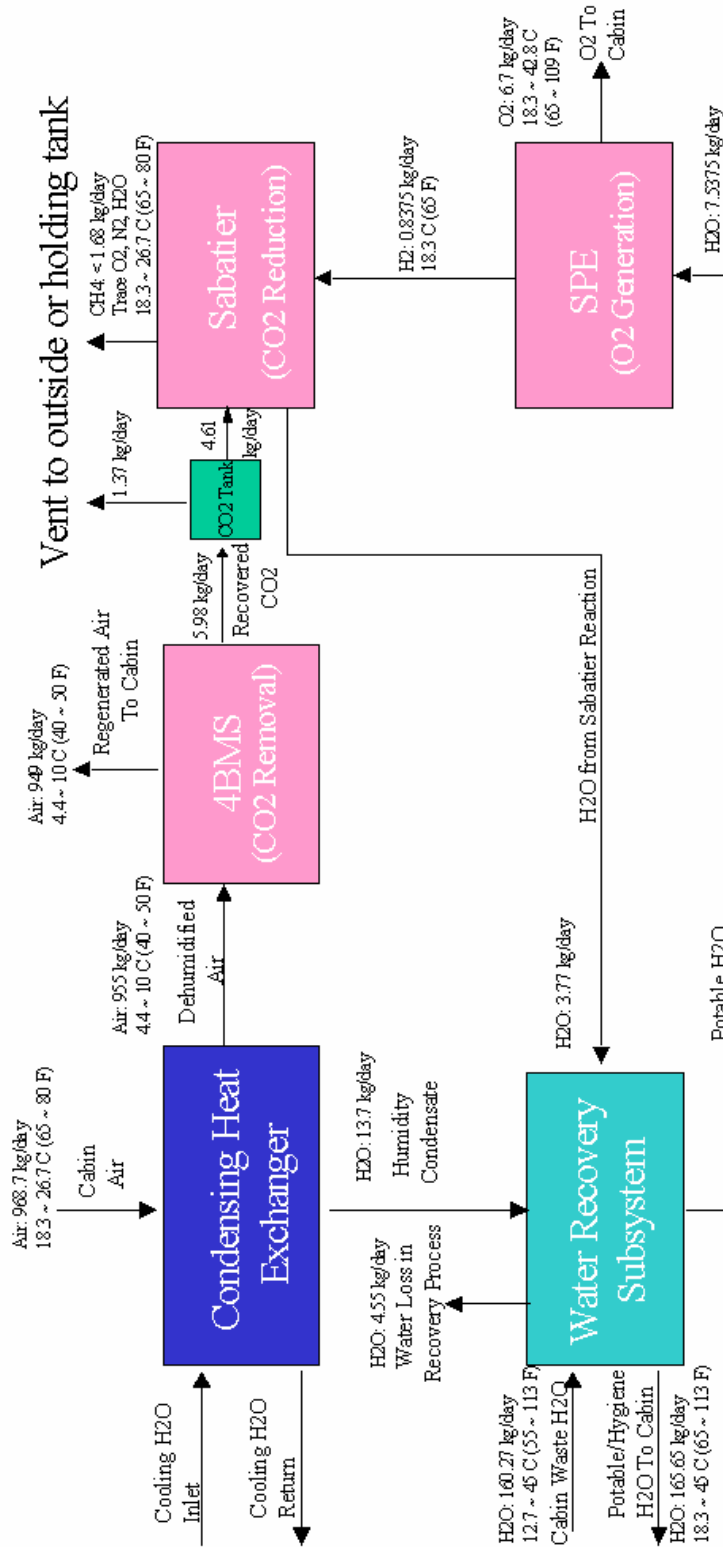

Acronyms

- 4BMS: 4 Bed Molecular Sieve
- AMS: Air Management Subsystem
- SPE: Solid Polymer Electrolysis
- TCS: Thermal Control Subsystem
- WMS: Water Management Subsystem

Appendix C – Internal Habitat Layout

First Floor

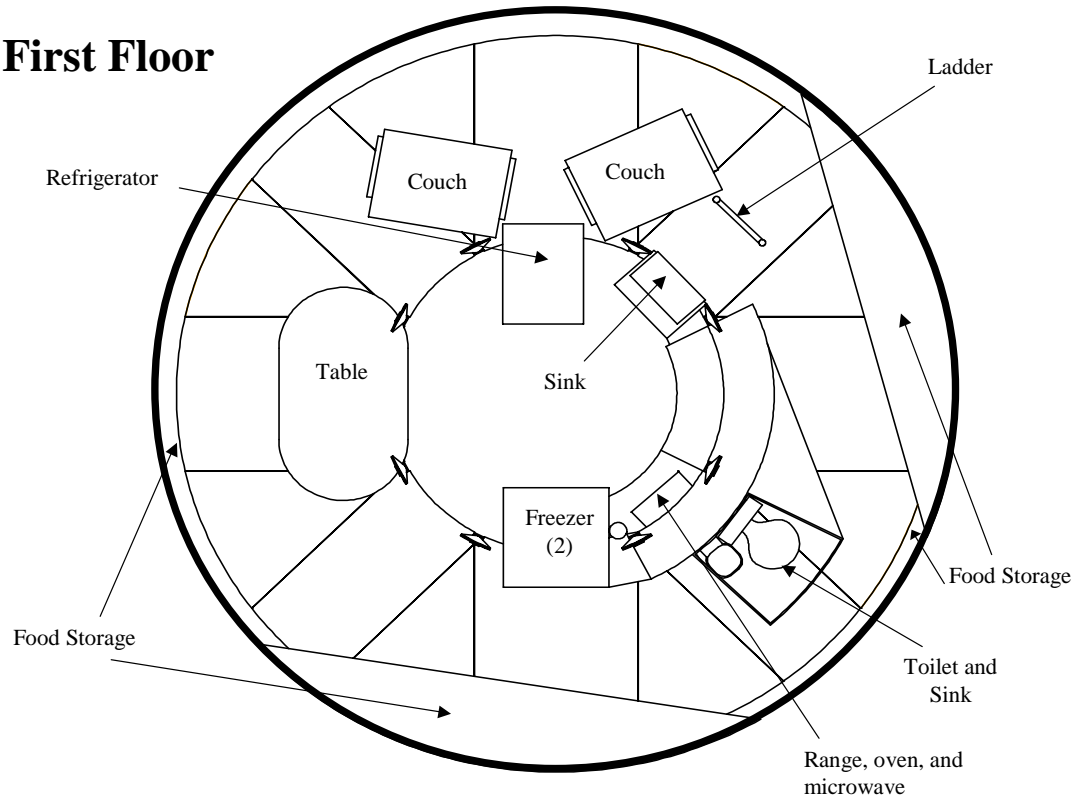

Second Floor

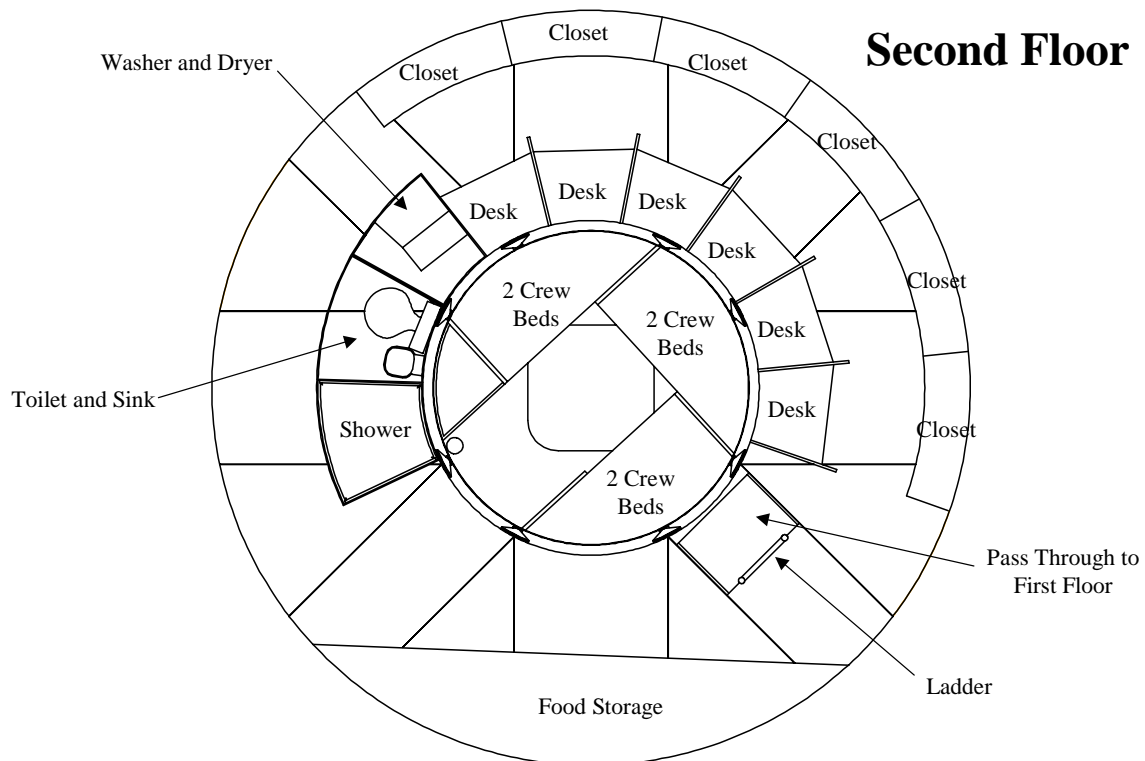

Third Floor

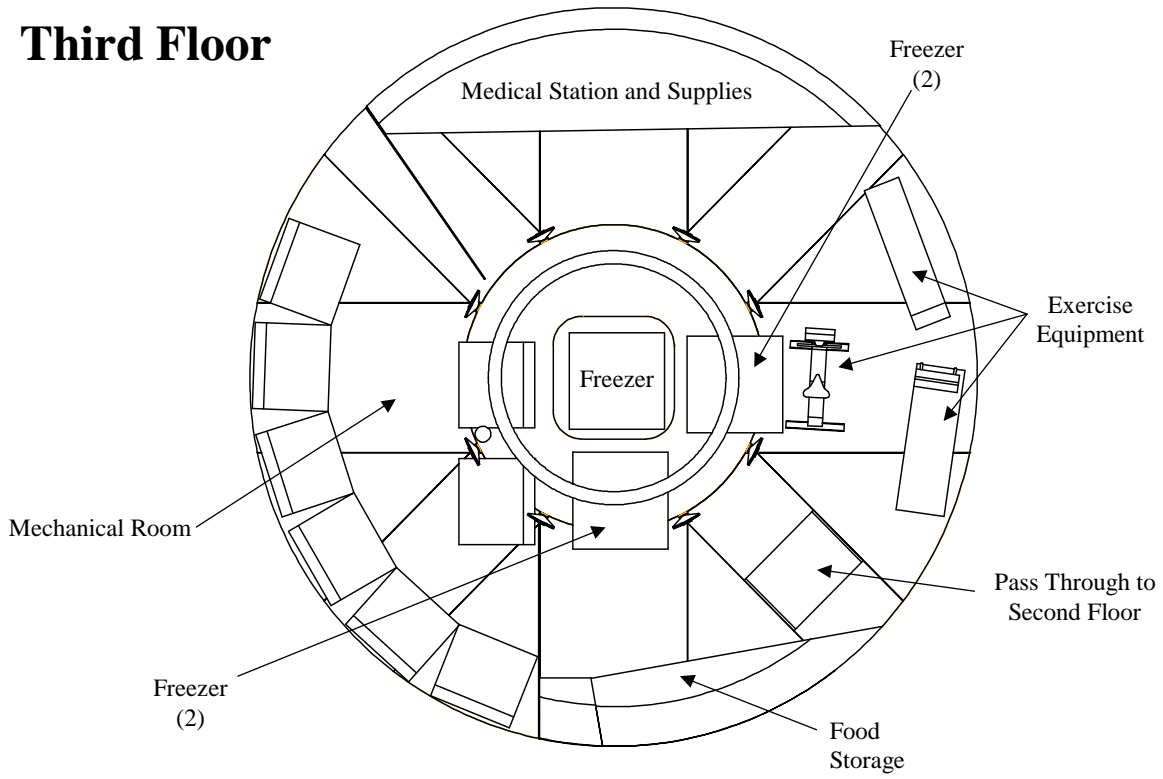

Attachment 3

Artificial Gravity Dynamics Assessment

Dynamical Considerations for an Interplanetary Human Transport Vehicle Featuring Nuclear Electric Propulsion and Artificial Gravity via Rotation

David Lee (NASA/JSC EG5)

Introduction/Abstract

This paper develops the basic dynamical considerations for the “fire baton” interplanetary human transport configuration. The “fire baton” configuration features nuclear-electric propulsion and artificial gravity via rotation. Turning dynamics and stability considerations for the rotating spacecraft are examined, and a unique solution is proposed to obtain pointing of the angular momentum vector with minimum additional fuel expenditure. Maneuvering schemes for some specific mission phases are also explored.

Configuration and Mission

The “fire baton” configuration is a concept for an interplanetary human transport vessel. It features artificial gravity by means of rotation. Low-thrust nuclear-electric propulsion (NEP) is envisioned. In shape, it is indeed baton-like, with the habitat at one end, the reactor/power generation module at the other, and a long lightweight truss in between. Propellant tanks may be near the center of mass, and the electrical propulsion units are probably mounted somewhere along the truss. (See Joosten, George, et al for a detailed description of the fire baton configuration.)¹

The fire baton is envisioned as a general-purpose human transport, allowing human access to much of the solar system. However, the current design missions focus on Mars. The vehicle is envisioned to be based at the Earth-Moon L1 libration point. It would depart from there and rendezvous with pre-positioned assets at the Sun-Mars L1 point, or possibly a high Mars orbit. From there it would return to the Earth-Moon L1.

Many previous designs for artificial gravity human transports, particularly those employing NEP, have been ‘split’ designs, with both rotating and non-rotating sections. The fire baton concept, on the other hand, is an all-rotating design.

The split rotating/non-rotating designs have several inherent disadvantages: They tend to be somewhat structurally complex. They must employ huge rotating joints to connect the sections. In some cases these joints must transfer massive amounts of electrical power across their interface. Mass shifting mechanisms may be required to constantly maintain the mass center and rotational axis of the rotating section within the limits of the joint capability.

The advantages of the all rotating design are structural and mechanical simplicity and lack of a huge rotating joint. The result may be a significant mass savings and reduced mission risk.

So why did the previous studies opt for split rotating/non-rotating configurations? The disadvantage of the all-rotating configuration is that the angular momentum vector must track the line of thrust. In other words, the axis of this large, spinning vehicle - essentially a massive gyroscope - must turn. It seems likely that the potentially large propellant cost of this maneuvering is what drove previous studies away from the all-rotating to the split designs. However, we feel we’ve stumbled on an innovative way to overcome these concerns and reap the benefits of the all-rotating design.

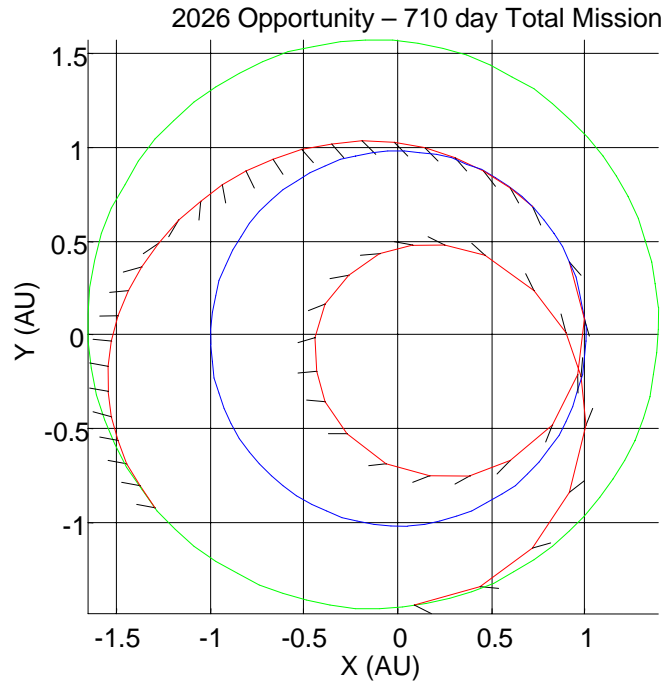

Figure 1 - Example Showing Thrust Pointing for a Low Thrust Earth-Mars Round-Trip Trajectory
(from Jerry Rauwolf of SAIC/Chicago)²

Turning Dynamics

While many unmanned spacecraft have been spin stabilized, manned spacecraft to date have all been 3-axis stabilized. Some designers of manned spacecraft may be surprised to know that turning the rotational axis of a spin-stabilized spacecraft is fundamentally different from performing an attitude change on a 3-axis stabilized spacecraft.

The main practical difference is this: For a 3-axis stabilized spacecraft, an attitude change of any magnitude is essentially similar in propellant cost - there is a jet firing to start a rotation, and another to stop the rotation at the desired attitude, with perhaps some corrective bursts in between. However, for a change to the direction of the rotational axis for a spin stabilized spacecraft, the propellant required is proportional to the magnitude of the angular directional change. For example, to change the direction of the rotational axis five degrees requires five times the propellant of a one degree directional change.

The reason can be seen by looking at the equation for rotational motion of a rigid body about its center of mass in the inertial frame:

$$\frac{d}{dt} \mathbf{L} = \mathbf{N}$$

where \mathbf{L} is the angular momentum vector of the rigid body, and \mathbf{N} is the vector sum of torques being applied to the body.

3-axis inertially stabilized spacecraft maneuver in the following way: They apply a torque to create an angular momentum, then as they approach the desired attitude, they apply an opposite torque to remove the angular momentum.

Spin stabilized spacecraft, on the other hand, maintain an angular momentum of near constant magnitude. A torque is required to produce a rate of change to the angular momentum vector. To keep angular momentum magnitude constant, the torque must be oriented perpendicular to the angular momentum vector. The torque must be maintained over time in order to cause a finite change in direction of the angular momentum vector.

Given a torque vector maintained perpendicular to the angular momentum vector, the total angular 'travel' of the angular momentum vector is proportional to two things: 1.) the magnitude of the torque, and 2.) the duration of its application.

Torque Generation Options and Trades

Torque for steering can be generated in one of three ways:

- 1.) by an innovative use of the primary low-thrust propulsion system,
- 2.) by means of an RCS-type system, or
- 3.) by a hybrid system strategically employing both methods.

Option 1 - Primary Low-Thrust Propulsion: Steering torque can be generated using the primary low thrust propulsion system, even as it performs its propulsive function. The propulsion unit must be offset from the vehicle center of mass. (The thrust vector is parallel to the axis of rotation of the rotating vehicle, but offset laterally.) As the vehicle rotates, the thrust level is cycled, so that the thrust over one half of the rotation is greater than the thrust over the other half. The net result is an effective average torque, which can be used to steer the vehicle.

Note that for the fire baton type configuration, thrusters should lie along the long axis of the vehicle, close to the minor principal axis of inertia, in order to avoid exciting extraneous motion.

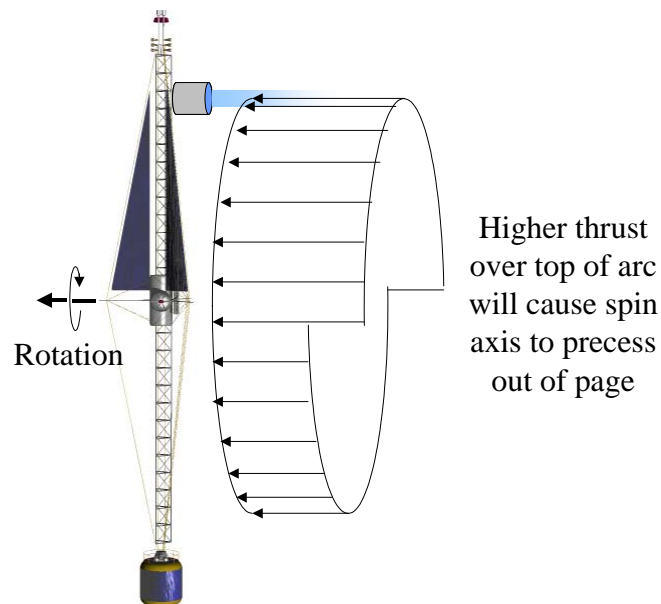

Figure 2 - Steering via Thrust Cycling of Primary Low-Thrust Propulsion

This method performs the steering function using thrust that is necessary for the propulsive function anyway in most cases. The average thrust over the cycle must equal the commanded thrust level for the propulsion function. Additional propellant usage for steering (beyond that required for propulsive purposes) should be minimal. Any additional propellant expenditure would be due to propulsive inefficiencies induced by the thrust cycling.

Preliminary simulations suggest that neither the offset of the propulsion unit from the center of mass nor the cycling of the thrust seem to excite much extraneous motion. The low thrust-to-mass ratio of the spacecraft, together with the particular dynamic characteristics of the “baton” type design probably account for this.

One concern which has been raised is that the nuclear power system might not be able to accommodate the required cyclic variations in power. A proposed solution is to employ two thrusters, offset in opposite directions from the CG, and thus cycled on opposite cycles. The net power of the two thruster sets would remain constant. Another option is to use a thruster throttling scheme that maintains constant power, but varies fuel flow rate.

This is similar to a system proposed by some Soviet researchers in the 1970’s, however the previous concept involved a three-armed vehicle concept and used three thruster pods to maintain a constant total torque - a “balanced” system so to speak.^{3,4} The concept presented herein can use a single thruster, with torque which varies around the cycle. This means it can be used with the fire-baton, or other linear configurations, including possibly tethered configurations. (In fact, many of our simulations were performed assuming two tethered masses.)

Many, possibly hundreds, of spin stabilized satellites have employed timed thruster pulses to correct pointing of a spin axis. But none of them, so far as we know, have used a low-thrust propulsion system, asymmetrically mounted and with cyclic throttling, to accomplish an attitude change. And none of them have used the main propulsion system in this manner to obtain the attitude maneuver during the course of propulsive thrusting.

Option 2 - RCS-Type System: Jets located near ends of rotating craft would fire bursts parallel to the angular momentum vector during a limited part of the rotation cycle. This is similar to systems employed on conventional spin-stabilized satellites.

Because of the propellant costs for this type of system (see below), propulsive efficiency becomes very important. Arcjets are more efficient than conventional chemical RCS systems, and this architecture has plenty of power for arcjets, so an advanced arcjet system might be a logical option.

This type of system could have some propulsive effects as well as steering effects (see below).

Option 3 - Hybrid system: This would employ steering both via the main low-thrust propulsion and an RCS type system as well. The question is when and how much you employ the different system components. The RCS-type system could be used to augment turning with the main NEP thrusters during periods where the required turn rates are high, or the commanded thrust from the main system is not sufficiently high to generate the required turn rate. A hybrid system could also reorient the spacecraft during periods when the main propulsion system is dormant.

The final system configuration will need to be designed based on both mission/trajectory and vehicle/hardware related criteria. Mission and trajectory related criteria would include:

- Required turning rates for the various mission phases.
- Total turn angle, possibly broken into mission phases.

Vehicle and hardware related criteria would include:

- Fuel properties (compatibility with long fuel lines).
- Power line losses and cabling mass.
- Power system ability to absorb rapid load changes.
- Deployment configurations for power and fuel lines.
- Thruster throttling/variation capability (variability range, maximum rate of change, and efficiency effects).

Performance Calculations - Available Turn Rates

Turning performance, in terms of available turn rate and propellant consumption (if any) turn out to be governed by simple equations.

To derive equations for turning rate we assume small angular motion of the angular momentum vector per rotation, and rotation about the major principal axis of inertia. Integrating the torque effects over a full rotation, we find that turning rate can be expressed as:

$$\omega_T = f \frac{r T_a}{\omega_S I_X}$$

Variables:

ω_T is the angular rate of the turn.

f is a function of the thrust cycle profile (see figure 3 below).

r is the radius of the thruster from center of mass/rotation axis.

T_a is the amplitude of the pulsed thrust cycle (not necessarily the same as magnitude).

I_X is the major principal moment of inertia.

ω_S is the spin rate.

For multiple thrusters, terms of this equation can be applied additively (i.e. superposition applies).

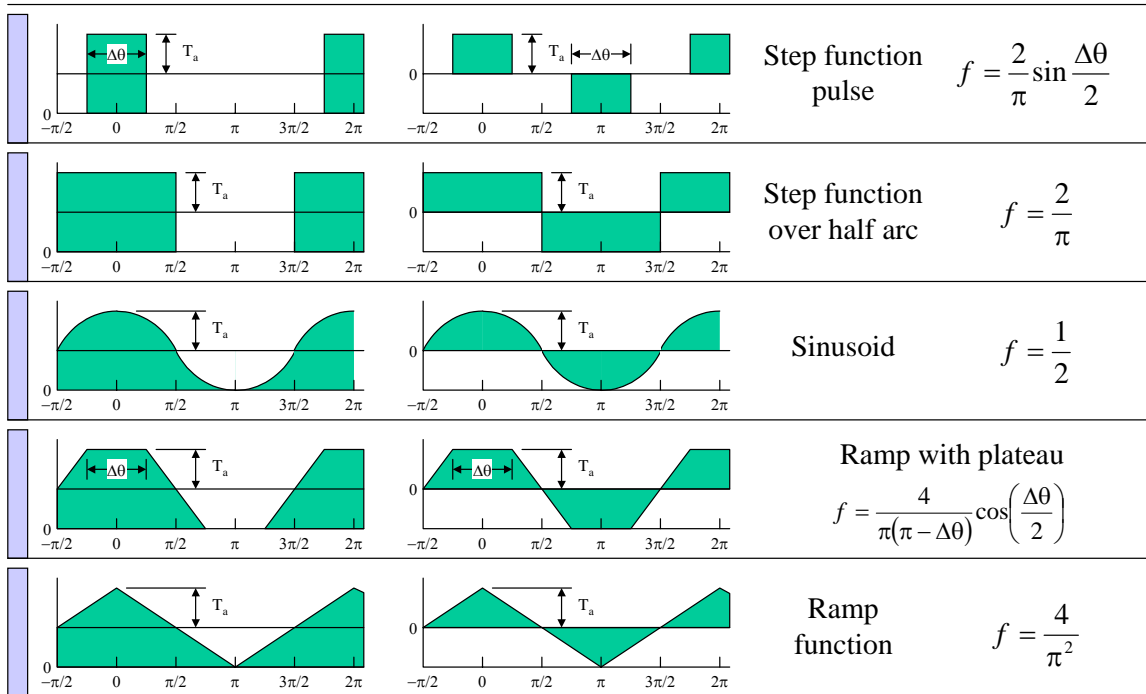

Figure 3 - Thrust Profile Factor (f) Calculations for Various Thrust Cycles

The following dynamical properties are used herein for the Fire Baton configuration:

- Thruster radius (r) is 56 m.
- Major principal moment of inertia (I_X) is $2.5 * 10^8 \text{ kg} * \text{m}^2$.
- Rotation rate (ω_S) is 4 rpm, or 0.4189 radians per second.

The best expected turning performance using the main low-thrust propulsion system is estimated as follows:

A single NEP thruster system with $T_a=50$ N, could yield maximum available turn rates between 54 and 84 degrees per day depending on the thrust profile.

A system using dual NEP thrusters on opposite ends of the vehicle, counter-cycling with $T_a = 33.33$ N each could produce maximum turn rates between 72 and 112 degrees per day. (This would be a 50% thrust variation per thruster, assuming a constant total thrust of 200 N)

From these rate estimates, it appears that steering via the main low-thrust propulsion could be sufficient for missions based at the libration points, and possibly in very high orbits. In particular, the control authority looks to be adequate for operations from the Earth-Moon L1 libration point. (By comparison, the average lunar orbital rate is about 13.2 degrees per day.) Required turning rates in the interplanetary trajectory phase should be much lower. However, these rate projections are based on positioning the thrusters out near the ends of the vehicle - a near optimal thruster location - and this may not be the case, as other design considerations may prevail in the location of the primary NEP thrusters.

Steering via the main low-thrust propulsion doesn't appear to be well suited to lower orbits. Some other approach would be required if the Fire Baton configuration were required to operate in lower planetary orbits.

Performance Calculations - Propellant Consumption for RCS Steering

For propellant consumption, recall again that if the main low-thrust propulsion is employed for the turn, the propellant cost may be minimal. If an RCS-type system is employed, there will be some propellant cost, although some propulsive effect may also be obtained. The following calculations are for "pulsing" thrusters, such as RCS-type systems.

To find the propellant consumption per turn angle, the effective propellant mass consumption rate (\dot{m}) is divided by the effective turn rate. For an RCS-type system, the propellant mass per turn angle is:

$$\frac{\dot{m}}{\omega_T} = \frac{\Delta\theta}{2 \sin(\Delta\theta/2)} * \frac{I_X \omega_S}{g_0 I_{SP} r}$$

Where the additional variables are:

- $\Delta\theta$ is the angle of rotational travel during the thruster pulse.
- g_0 is the sea-level standard value for gravitational acceleration.
- I_{SP} is the specific impulse of the turning thrusters.

The first term can be thought of as a sort of inverse 'turning efficiency'. Notice that as $\Delta\theta$ approaches zero, the first term approaches one - the best efficiency case.

Figure 4 shows how turn rate and propellant mass per turn angle vary with thrust arc ($\Delta\theta$), for a given thruster configuration. Values are normalized: Prop mass per turn angle is scaled to the best efficiency value for the configuration. Turn rate is scaled to the maximum turn rate for the configuration. The normalized values will be the same for any thruster configuration.

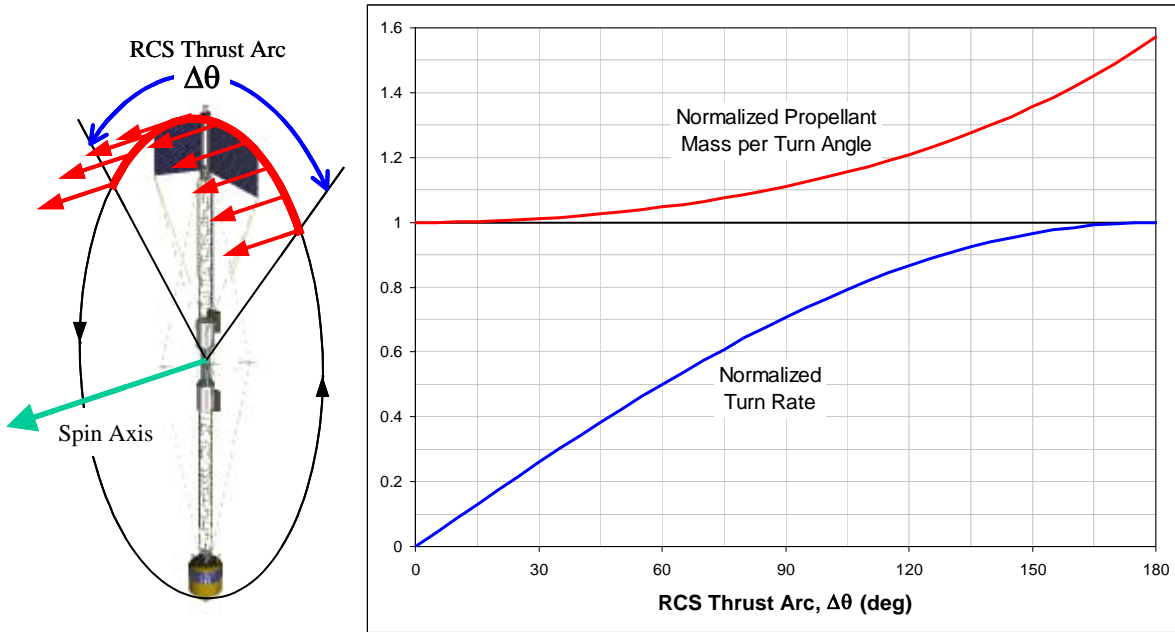

Figure 4 - Normalized Propellant Mass per Turn Angle and Turn Rate Vs. RCS Thrust Arc ($\Delta\theta$)

If the RCS-type maneuvers are performed in a single thrust direction (i.e. without thruster coupling) some propulsive effect will be realized. It may not be fair to tally the “cost” (i.e. propellant mass) required for an RCS turn without taking the propulsive effect into account. In general, the adjusted propellant mass would be the RCS propellant mass required for the turn (M_{RCS}) minus the propellant mass required for the high-specific-impulse NEP system to produce an equivalent propulsive effect (M_{NEP}):

$$M_{Adjusted} = M_{RCS} - M_{NEP}$$

For the case where the vehicle mass is changed negligibly by the maneuver, a simple relation for the adjusted maneuver cost can be developed from impulse calculations:

$$M_{Adjusted} = M_{RCS} \left(1 - \frac{I_{SP\,RCS}}{I_{SP\,NEP}} \right)$$

This simplified relation expresses the adjusted maneuver cost as a function of only the total RCS propellant mass and the ratio of specific impulses. This relation actually provides a good approximation for the mass variations expected for maneuvers of the Fire Baton configuration.

A more rigorous approach uses the rocket equation. First, a final vehicle mass (M_f) must be assumed. Lower values result in a more conservative result, so the expected mass at the end of the final maneuver is a good candidate. Dry mass would be even more conservative.

First, the equivalent linear velocity change for the RCS maneuver is calculated:

$$\Delta V = g_0 I_{SP\,RCS} \ln \left(\frac{M_{RCS} + M_f}{M_f} \right)$$

Then the amount of propellant required for the high-efficiency NEP system to produce an equal velocity change is calculated:

$$M_{NEP} = M_f \left(e^{\left(\frac{\Delta V}{g_0 I_{SP\ NEP}} \right)} - 1 \right)$$

These equations can actually be combined into a single equation for adjusted RCS maneuver propellant cost:

$$M_{Adjusted} = M_{RCS} - M_f \left(\left(\frac{M_{RCS}}{M_f} + 1 \right)^{\left(\frac{I_{SP\ RCS}}{I_{SP\ NEP}} \right)} - 1 \right)$$

This result is only approximate, but it should be conservative (i.e. the adjusted propellant mass will be higher than the actual value) if the value for the final mass M_f is small enough.

Table I - Propellant Mass for RCS Steering and Spin-Up

RCS Propellant	Isp (s)	Mass per 360° (kg)	Adjusted Mass per 360° (kg)	Mass per Spin-Up (kg)
Arcjet	1000	1199.3	802.7	190.8
Arcjet	800	1499.1	1103.7	238.5
Cryo H2/O2	450	2665.1	2274.1	424.0
MMH/N2O4	310	3868.7	3482.2	615.5
MMH monoprop	280	4283.3	3898.2	681.5

Table I shows propellant mass required for RCS steering for various propellant types. These results show the importance of efficient turning propulsion, if an RCS-type system is to be employed, especially considering that multiple 360 degree steering turns may be required over a mission. The masses involved are not prohibitive for libration point and high orbit operations, considering that the Fire Baton could be in the range of 200 metric tons. The method may be especially attractive as part of a hybrid system, augmenting the steering capability of the primary low-thrust propulsion system.

It's also clear, however, that it wouldn't be practical to use an RCS-type system to track the velocity vector in a low planetary orbit. The propellant costs would soon become prohibitive. So again, if the Fire Baton configuration were required to operate in low planetary orbits, another approach would be required.

Dynamic Stability and Energy Damping

Since the craft rotates, it can be designed as a spin-stabilized spacecraft. This is an advantage of sorts, as it frees us from the problems of attitude control, in the 3-axis sense, for most of the mission. It does, however, introduce some unusual factors for a manned spacecraft.

To be a stable spinner, the intended rotational axis should be the major principal axis of inertia. The fire baton configuration can satisfy this condition easily, given some judicious mass distribution to make the moment of inertia about the spin axis (or x-axis) slightly greater than that of the next largest principal axis (the y-axis).

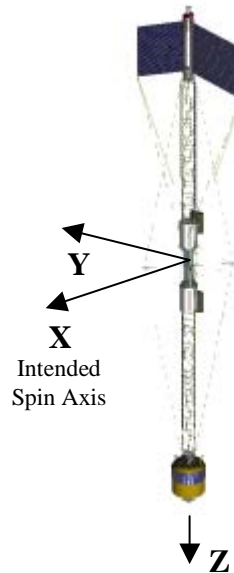

Figure 5 - Fire Baton Coordinate Axes

Previously in this paper, we've spoken of the angular momentum vector, and tacitly assumed that the rotational axis was aligned with the angular momentum vector. For fire baton, this is probably a reasonable assumption for many purposes, but the design must employ features to make it happen.

In fact, the rotational axis of the craft will not always be perfectly aligned with the major principal axis of inertia, and neither may be aligned with the angular momentum vector. This will result in nutation - extraneous motion of the vehicle. This extraneous motion represents additional energy in the rotating spacecraft configuration. As this energy damps, the rotational axis and the major principal axis of inertia will converge to the angular momentum vector. As we saw before, the angular momentum vector is only affected by external torques or mass leaving the system.

So in order to damp extraneous motion, we need to incorporate energy dissipating devices into the design. Energy damping options include:

- 1.) Passive damping mechanisms. Some degree of passive damping occurs in almost any structure. Built-in passive damping elements include water tanks, liquid fuel tanks, long structural elements, even crewmembers (though you don't want the oscillations to become an annoyance to them). Tanks containing liquids can be specially configured for passive damping. Special passive damping devices can be added, such as 'shock absorber' type dampers in structural members and along structural cables. Various other liquid and solid friction-based damper configurations might also be employed.
- 2.) Control moment gyros might be employed to damp extraneous motion. Since the damping effort would be oscillatory in nature, long periods between 'desaturations' might be possible. Also, desaturation using the vehicle rotational motion and main propulsion steering capability might be possible.
- 3.) An RCS-type attitude control scheme could be employed to damp extraneous motion once it exceeded deadband rules for the rates and angles of motion.

Preliminary simulations seem to indicate that even step-function thrust cycling seems to excite very little nutation in the fire baton configuration. It seems possible that passive energy damping mechanisms may be adequate to provide attitude stabilization for most of the mission.

The simulations also suggest that the mass characteristics of the vehicle should be selected to make it a stable spinner, but not too stable. The relationships between principal moments of inertia should be as follows:

The x-axis is the intended spin axis. This must be the major principal axis of inertia for the craft to be a stable spinner with convergent dynamics for energy dissipation.

The y-axis, perpendicular to both the truss and the intended spin axis, should have a moment of inertia less than the x-axis, but only slightly less. Preliminary simulations suggest configurations with I_y nearly as great as I_x experience less excitement of extraneous motion from thruster cycling than those with more pronounced differences. Though the desire is to have I_x not much larger than I_y , the larger I_x to I_y ratio does offer more stability in the “static” sense. The relative sizes of I_x and I_y will be determined by the need to accommodate crew movement, other mass disturbances and variation, and the effects of thruster offsets from z-axis centerline among other design criteria.

The z-axis, the long axis along the truss, will have by far the smallest moment of inertia of any principal axis for the Fire-Baton configuration. We can use this to our advantage, as a small I_z helps to minimize the cost of the midcourse reversal maneuver (see below).

It's worth noting that the exact major principal axis of inertia will shift around somewhat as the mass makeup of the craft shifts (e.g. propellant mass is expended, crew members move about). The location of the center of mass will move also. This is true for any spacecraft, but especially true for a manned spacecraft. It is important that the vehicle axis of rotation should be free to move to the changing major principal axis. (In other words, the attitude should be allowed to ‘float’ a little.) It will save us a lot of design headaches. The effect on the net thrust of the main propulsion is small and probably easily correctable, since the off-axis components will mostly cancel over a rotation. It does probably mean, however that the main propulsion must have a small range of gimbaling capability about an axis parallel to the main truss.

‘Midcourse Flip’ Maneuver

In some low thrust trajectories, there is a near 180 deg reversal of thrust direction somewhere near the midpoint of the trajectory. Considering the turning rates and propellant masses discussed so far, using these methods could present a problem. Fortunately, another option presents itself.

Fire baton has a very pronounced minor principal axis of inertia - the long axis along the truss between the reactor and crew module. While the vessel is rotating at 4 rpm, it is possible to excite a rotation about the minor axis, and then damp this rotation, using a reasonable amount of control authority. The effect is that the vessel ‘flips’ about its long minor axis even while it is doing its usual artificial gravity rotation. The vessel, and its propulsion system, end up facing the opposite direction, but the angular momentum vector is changed very little in the inertial frame. (This would most likely be the sizing case for the attitude control system in that axis.)

Spiraling Strategies

An inherent trade-off in an all-rotating NEP design involves operations in the near vicinity of planetary bodies, i.e. spiraling in and spiraling out of close orbits. From the maneuverability and propellant mass estimates above, the standard maneuvering strategies are not well suited to close orbit operations. Current design missions call for libration point basing, which avoids this problem. However, if operation in low planetary orbits is desired, several options present themselves:

- 1.) Match Turn Rate - Select a turn rate to match the orbit rate. Because of the propellant mass required for turning via the RCS-type systems, the NEP system would probably have to be employed (unless insertion

could be accomplished quickly). For projected Fire Baton NEP upper-limit turn rates (for a configuration optimized for NEP turning), this would be limited to very high orbits (3 to 7 day period minimum).

2.) Reduce Rotation Rate - If the spin rate is reduced, maneuverability improves. This could provide access to lower orbits. However, this also reduces the artificial gravity level. For instance, reducing spin rate from 4 rpm to 2 rpm doubles the available turn rate (allowing access to orbits with half the period), but it reduces the artificial gravity level to 1/4 g.

3.) Gravity-Gradient Orientation - If the NEP propulsion configuration is symmetrical about the C.G., it might be possible to de-spin the vehicle entirely and spiral to lower orbits with the vehicle in a gravity-gradient orientation. This would mean, however, a period with no artificial gravity for the crew. It would also require the reactor to be certified to operate in zero-g.

4.) Thrust Reversal - In this approach, the angular momentum vector is left unchanged. The thrust direction is reversed every half revolution in order to accomplish the spiraling. This can be accomplished in two ways, either a.) a flip about the minor principal axis every half-orbit, or b.) redundant sets of thrusters on opposite sides of the vehicle. Obviously, there is a penalty in propulsive efficiency and spiral time as compared with continuous thrusting in the optimal thrust direction. The thrust in this scheme is often pointed far from the optimal direction.

Ultimately, the need for low-orbit operations should be based on trades involving the mass of the transport vehicle versus the mass of the surface/low orbit operations vehicles. Timing restrictions on the mission certainly might also be a factor.

Conclusions

For manned spacecraft concepts employing NEP and artificial gravity, all-rotating designs (such as the Fire Baton concept) have advantages of mechanical and structural simplicity, possible mass savings, and reduced mission risk when compared to mixed designs with both rotating and non-rotating sections. The challenge is to steer the rotational axis to track the line of thrust for the low-thrust trajectory, without incurring large propellant mass penalties.

Mounting the primary low-thrust propulsion units away from the center of mass and varying the thrust as the spacecraft rotates allows steering of the rotating spacecraft. Using the main low thrust propulsion in this manner for steering, even while it performs its propulsive function, minimizes the propellant mass required for turning. This may make "all-rotating" designs more attractive. RCS-type schemes for steering are also possible, but propulsive efficiency is very important for that type of system. Hybrid systems, employing both methods, may ultimately be desirable.

Available steering rates and/or propellant mass required for turning may restrict low orbit operations for Fire Baton type configurations, though some workarounds may be possible. However, the Fire Baton configuration is well suited to libration point basing. If low orbit operations are desirable, some workaround options are available.

Designing a Fire Baton type spacecraft to have specific mass properties (i.e. moments of inertia) will be important for dynamic stability and motion control. The Fire Baton configuration lends itself to excellent dynamic stability properties. It's possible that extraneous motion may be controlled by passive or non-propulsive means. Fire Baton also lends itself to a dynamic scheme for mid-course thrust reversal by means of a rotation about its long axis.

References

- 1 B. K. Joosten, *Preliminary Assessment of Artificial Gravity Impacts to Deep-Space Vehicle Design*, Doc. No. EX-02-50, NASA Lyndon B. Johnson Space Center, Houston, TX.
- 2 - Earth-Mars round trip trajectory and plot from Jerry Rauwolf, SAIC/Chicago

3. V. I. Gurman, Yu. B. Popov, and V. V. Salmin, *Kosmicheskie Issledovaniya*, Vol. 8, No. 5, pp. 684-692, September-October 1970.
4. V. V. Vasil'ev and V. V. Salmin, *Kosmicheskie Issledovaniya*, Vol. 14, No. 3, pp. 336-342, May-June 1976.