

**KOBE 10mm Straight Drill**



**DS4510L**

10mm Jacobs chuck, stall-resistant, safety lever throttle, high performance, planetary gearing, 3/8" - 24 spindle thread.

**Air inlet thread:** 1/4" NPT. **Chuck capacity:** 10mm.  
**Spindle thread:** 3/8" - 24. **Minimum air hose size (ID):** 3/8" (10mm).  
**Air pressure:** 90psi/6.3bar.  
**Air consumption:** 4cfm\* (144ltr/min).  
**Noise level:** 88dBA.  
**Sound power level:** 95dBA.  
**Vibration level:** 2.5m/s<sup>2</sup>.  
**Overall length:** 206mm.

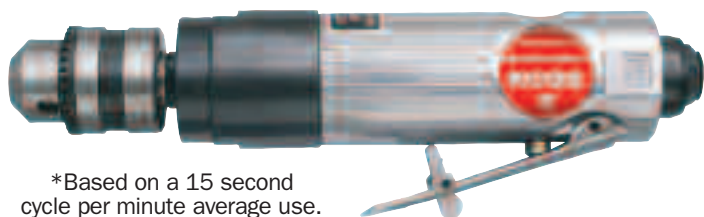

\*Based on a 15 second cycle per minute average use.

Free Speed (rpm)	Weight each	Order Code
4,500	0.90kg	<b>KBE-270</b> <b>-1450N</b>

**10mm Reversible Angle Drill**



**DAR1510**

10mm Jacobs chuck, fingertip control of reverse, reverse exhaust, overall head height 94mm, 3/8" - 24 spindle thread.

**Air inlet thread:** 1/4" NPT.  
**Chuck capacity:** 10mm.  
**Minimum hose size:** 3/8"(10mm).  
**Air pressure:** 90psi/6.3bar.  
**Air consumption:** 4cfm\*

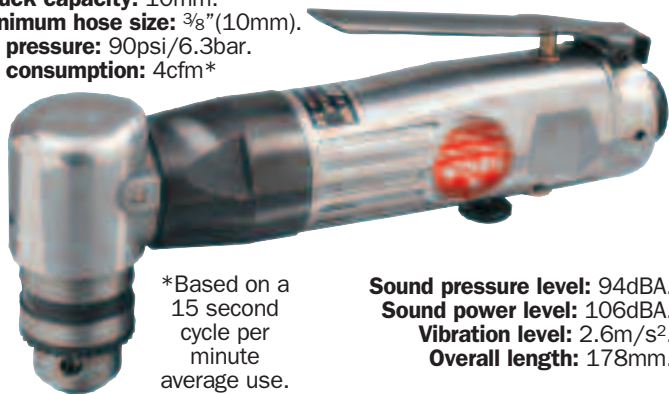

\*Based on a 15 second cycle per minute average use.

**Sound pressure level:** 94dBA.  
**Sound power level:** 106dBA.  
**Vibration level:** 2.6m/s<sup>2</sup>.  
**Overall length:** 178mm.

Free Speed (rpm)	Weight each	Order Code
1,500	1.80kg	<b>KBE-270</b> <b>-1425M</b>

**10mm Pistol Drill**



**DP2210**

10mm Jacobs chuck, stall resistant, heavy duty bearings, 1/2hp motor, 3/8" - 24 spindle thread.

**Air inlet thread:** 1/4" NPT.  
**Minimum air hose size (ID):** 3/8" (10mm).



**Chuck capacity:** 10mm.  
**Spindle thread:** 3/8" - 24.  
**Air pressure:** 90psi/6.3bar.  
**Air consumption:** 4cfm\* (144ltr/min).  
**Sound pressure level:** 87dBA.  
**Sound power level:** 103dBA.  
**Vibration level:** 1.5m/s<sup>2</sup>.  
**Overall length:** 165mm.

\*Based on a 15 second cycle per minute average use.

Free Speed (rpm)	Weight each	Order Code
2,200	1.10kg	<b>KBE-270</b> <b>-1375C</b>

**10mm Heavy Duty Pistol Drill**



**DP2610**

10mm Jacobs chuck, stall resistant, directional front exhaust, hammer finish casing, needle bearing gears, 3/8" - 24 spindle thread.

**Air inlet thread:** 1/4" NPT.  
**Minimum air hose size (ID):** 3/8" (10mm).  
**Chuck capacity:** 10mm.  
**Spindle thread:** 3/8" - 24.  
**Air pressure:** 90psi/6.3bar.  
**Air consumption:** 4cfm\* (144ltr/min).

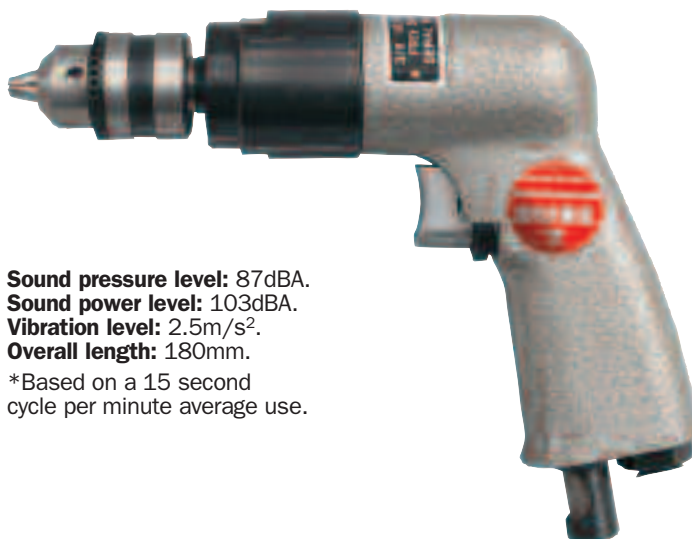

**Sound pressure level:** 87dBA.  
**Sound power level:** 103dBA.  
**Vibration level:** 2.5m/s<sup>2</sup>.  
**Overall length:** 180mm.

\*Based on a 15 second cycle per minute average use.

Free Speed (rpm)	Weight each	Order Code
2,600	0.90kg	<b>KBE-270</b> <b>-1390D</b>

**10mm Reversible Pistol Drill**



**DPR1810**

10mm Jacobs chuck, stall resistant, heavy duty bearings, thumb switch for reverse, suitable for screwdriving.

**Air inlet thread:** 1/4" NPT.  
**Minimum air hose size (ID):** 3/8" (10mm).  
**Spindle:** 3/8" - 24.  
**Chuck capacity:** 10mm.  
**Spindle thread:** 3/8" - 24.



**Air pressure:** 90psi/6.3bar.  
**Air consumption:** 4cfm\* (144ltr/min).  
**Sound pressure level:** 85dBA.  
**Sound power level:** 101dBA.  
**Vibration level:** 5.4m/s<sup>2</sup>.  
**Overall length:** 165mm.

\*Based on a 15 second cycle per minute average use.

Free Speed (rpm)	Weight each	Order Code
1,800	1.40kg	<b>KBE-270</b> <b>-1400L</b>

**GROUP 270 AIR TOOLS - DRILLS**

**KOBE 10mm Straight Air Drill**

**BCSD10 - 10mm Composite Straight Air Drill**

Exhaust outlet adjusts 360° to direct air flow away from the operator. Compact and lightweight for ease of use in confined areas. Fast drill bit change with keyless chuck and a safety lever throttle. Ergonomic and comfortable hand grip.

- Motor power:** 0.45hp.
- Free speed:** 2,500rpm.
- Chuck size:** 10mm.
- Air inlet thread:** 1/4" BSP.
- Operating pressure:** 90psi/6.2bar.
- Minimum air hose size (ID):** 3/8" (10mm).
- Air consumption:** 4.0cfm\*.
- Sound pressure level:** 92dBA.
- Sound power level:** 110dBA.
- Vibration level:** 0.49m/s<sup>2</sup>.
- Overall length:** 215mm.

**NEW**



\*Based on a 15 second cycle per minute average use.



**Keyless chuck.**



**Exhaust outlet adjusts 360°**



**Safety lever throttle**



**Speed adjustment.**



Free Speed (rpm)	Weight each	Order Code KBE-270
2500	1.80kg	-6050K

**ABRASIVES & POWER TOOLS**

**KOBE 10mm Reversible Pistol Drill**

**FPD3175**

Suitable for drilling and screwdriving. Rubber handle provides grip and operator comfort. 3/8" keyless chuck. Stall resistant. Short gear case design. Heavy duty gearing system with oil-less bushing. Spring loaded rotor vanes. Rear exhaust. Ball bearing construction for a long tool life.

- Chuck capacity:** 10mm.
- Spindle thread:** 3/8" - 24.
- Air inlet thread:** 1/4" NPT.
- Minimum air hose size (ID):** 3/8" (10mm).
- Air pressure:** 90psi/6.2bar.
- Air consumption:** 3.35cfm\*.
- Sound pressure level:** 95dBA.
- Sound power level:** 100dBA.
- Vibration level:** 0.7m/s<sup>2</sup>.
- Overall length:** 188mm.

\*Based on a 15 second cycle per minute average use.

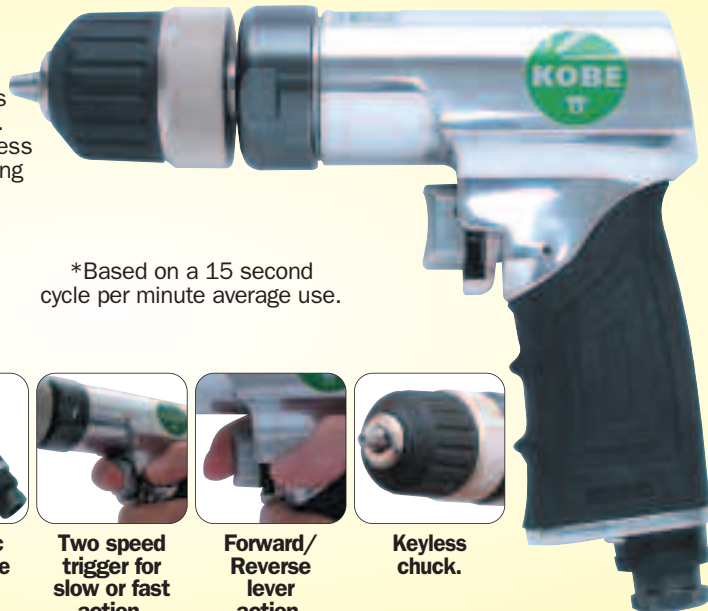

**Ergonomic comfortable grip.**



**Two speed trigger for slow or fast action.**



**Forward/Reverse lever action.**



**Keyless chuck.**

Free Speed (rpm)	Chuck size	Order Code KBE-270
1,800	3/8" (10mm)	-2152K

**KOBE 10mm Reversible Pistol Grip Drill**

**B2834**

Use for drilling and screwdriving. Two speed trigger (slow speed when pushed halfway). Directional lever accessible from both sides for left/right handed use. 10mm (3/8") chuck included. Planetary gears for longer life and smoother running. Ergonomic comfortable grip.

- Chuck size:** 3/8" (10mm). **Free speed:** 1,800rpm.
- Recommended air pressure:** 6.2bar (90psi).
- Air consumption:** 4cfm\* (113ltr/min).
- Air inlet thread:** 1/4" NPT.
- Spindle thread:** 3/8" - 24.
- Minimum air hose size (ID):** 3/8" (10mm).
- Noise level†:** 85dBA.
- Sound power level†:** 96dBA.
- Vibration level #:** 0.4m/s<sup>2</sup>.
- Overall length:** 185mm.
- †Per EN ISO 15744:2002.
- #Per EN 28927-5.

\*Based on a 15 second cycle per minute average use.



**Ergonomic comfortable grip.**



**Two speed trigger for slow or fast action.**



**Forward/Reverse lever action.**



**Complete with industrial chuck.**

Free Speed (rpm)	Weight each	Order Code KBE-270
1,800	1.10kg	-4310K

**PRODUCTS ARE ONLY AVAILABLE VIA YOUR DISTRIBUTOR**

**AIR TOOLS - DRILLS**

**KOBE 13mm Heavy Duty Pistol Drill**

**DP513**

13mm Jacobs chuck, high reduction gearbox, high torque, with side handle, 1/2hp motor.

**Air inlet thread:** 1/4" NPT. **Minimum hose:** 3/8" (10mm). **Chuck capacity:** 13mm. **Spindle thread:** 3/8" - 24.



**Air pressure:** 90psi/6.3bar.  
**Air consumption:** 4cfm\*  
**Sound pressure level:** 85dBA.  
**Sound power level:** 101dBA.  
**Vibration level:** 5.4m/s<sup>2</sup>.  
**Overall length:** 180mm.

\*Based on a 15 second cycle per minute average use.

Free Speed (rpm)	Weight each	Order Code
500	1.80kg	<b>KBE-270</b> <b>-1500E</b>

**13mm Reversible Heavy Duty Pistol Drill**

**DPR813**

13mm Jacobs chuck, thumb switch for reverse, auxiliary handle, suitable for screwdriving, heavy duty planetary gearing.

**Air inlet thread:** 1/4" NPT. **Minimum hose :** 3/8" (10mm). **Chuck capacity:** 13mm. **Spindle thread:** 3/8" - 24. **Air pressure:** 90psi/6.3bar. **Air consumption:** 4cfm\*.



**Sound pressure level:** 89dBA.  
**Sound power level:** 101dBA.  
**Vibration level:** 2.5m/s<sup>2</sup>.  
**Overall length:** 178mm.

\*Based on a 15 second cycle per minute average use.

Free Speed (rpm)	Weight each	Order Code
800	1.80kg	<b>KBE-270</b> <b>-1525F</b>

**KOBE 13mm Reversible Pistol Drill**

**FPD500**

Suitable for high torque drilling applications as well as screwdriving, hole sawing and cylinder honing. Rubber handle provides grip and operator comfort. 1/2" chuck. Adjustable side handle. Short gear case design. Heavy duty gearing system with oil-less bushing. Spring loaded rotor vanes. Rear exhaust. Ball bearing construction for a long tool life.

**Spindle thread:** 3/8" - 24.  
**Air inlet thread:** 1/4" NPT.  
**Minimum air hose size (ID):** 3/8" (10mm).  
**Air pressure:** 90psi/6.2bar.  
**Air consumption:** 3.65cfm\*.  
**Sound pressure level:** 95dBA.  
**Sound power level:** 100dBA.  
**Vibration level:** 0.4m/s<sup>2</sup>.  
**Overall length:** 240mm.

\*Based on a 15 second cycle per minute average use.

Free Speed (rpm)	Chuck size	Order Code
500	1/2" (13mm)	<b>KBE-270</b> <b>-2142K</b>

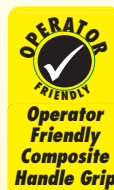

**ABRASIVES & POWER TOOLS**

**KOBE 13mm Reversible Pistol Grip Drill**

**B2842**

Use for drilling and screwdriving. Two speed trigger (slow speed when pushed halfway). Directional lever accessible from both sides for left/right handed use. 13mm (1/2") chuck and detachable side handle included. Planetary gears for longer life and smoother running. Ergonomic comfortable grip.

**Chuck size:** 1/2" (13mm). **Free speed:** 800rpm.  
**Recommended air pressure:** 6.2bar (90psi).  
**Air consumption:** 4cfm\* (113ltr/min).  
**Air inlet thread:** 1/4" NPT.  
**Spindle thread:** 3/8" - 24.

**Minimum air hose size (ID):** 3/8" (10mm).  
**Noise level†:** 86dBA.  
**Sound power level†:** 93dBA.  
**Vibration level #:** 0.4m/s<sup>2</sup>.  
**Overall length:** 218mm.  
**†Per EN ISO 15744:2002.**  
**#Per EN 28927-5.**



**Ergonomic comfortable grip.**



**Two speed trigger for slow or fast action.**



**Forward/Reverse lever action.**



**Complete with industrial chuck.**

\*Based on a 15 second cycle per minute average use.

Free Speed (rpm)	Weight each	Order Code
800	1.30kg	<b>KBE-270</b> <b>-4330K</b>

