



**vitrafix**™

FIXING ACCESSORIES / BY FAIRVIEW

AVAILABLE ACCESSORIES

[WWW.FV.COM.AU](http://WWW.FV.COM.AU)



## MEMBRANES

PHOTO	CODE	NAME	DESCRIPTION	UNIT QUANTITY
	MSE150	Pro Clima Solitex Extasana Wall Membrane - 150	1.50m x 36.5m roll – (55m <sup>2</sup> ) High performance monolithic nonporous membrane. Can be exposed to the elements for 90 days.	1
	MTE30	Weathertight Sealing Tape – Tescon Extora 60mm	60mm x 30m roll Tape used to seal Pro Clima membrane. Easy to cut, thin and flexible, can be applied to cold and wet surfaces, highly UV stabilised.	10
	MTEP60	Pro Clima Corner Tape – Tescon Extora Profil 60mm	60mm x 30m roll Split release paper for corner of window/door installations. Thin and flexible, can be applied to cold and wet surfaces, highly UV stabilised.	5
	MTES150	Pro Clima Sill Tape – Tescon Extoseal 150mm	150mm x 20m roll One-piece stretchable sill tape, no need for corner moulds, can be applied to damp surfaces, very high adhesion on cold surfaces, no heating necessary, highly UV stabilised.	2
	MSWD	Siniat Weather Defence	Weather Defence is a lightweight, deemed non-combustible, gypsum sheathing board. Can be exposed to the Australian elements for 12 months.	40 Sheets -or- 1 Sheet
	MWDJT60	Weather Defence Joint Tape 60mm x 25m	Tape used in conjunction with Siniat Weather Defence.	12
	MWDS38	GTEC Self Drilling Screw 38mm	Screws used in conjunction with Siniat Weather Defence.	Box of 1000

\*The use of these accessories needs to be checked for compliance on your project



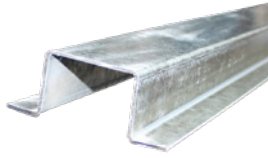
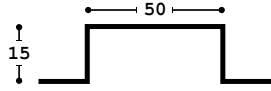
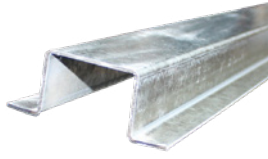
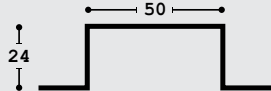
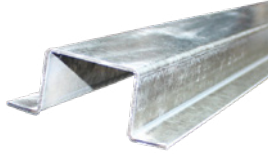
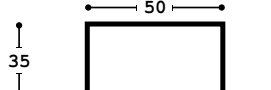
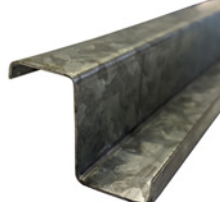
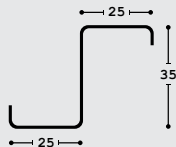

## SUB-FRAMING

PHOTO	CODE	NAME	DESCRIPTION	UNIT QUANTITY
	T5015	Steel Top Hat - 15mm 	6m length of top hat used as a cladding substrate. Grade: G2 Thickness: 1.15 BMT Coating: Z275	20
	T5024	Steel Top Hat - 24mm 	6m length of top hat used as a cladding substrate. Grade: G2 Thickness: 1.15 BMT Coating: Z275	20
	T5035	Steel Top Hat - 35mm 	6m length of top hat used as a cladding substrate. Grade: G2 Thickness: 1.15 BMT Coating: Z275	20
	TRM0901	Stryüm S Section - 35mm 	6.5m length of S section used as cladding substrate for Stryüm. Grade: G550 Thickness: 1.0 BMT Coating: AZ150	20

\*The use of these accessories needs to be checked for compliance on your project

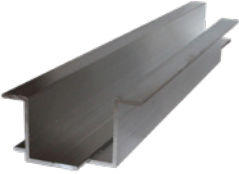
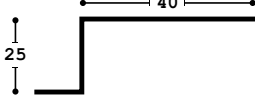

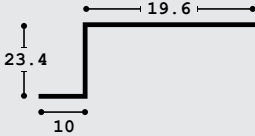
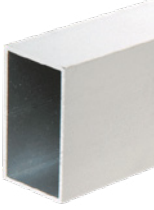
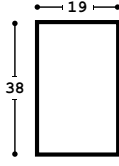

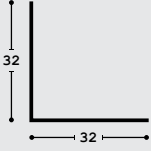
## EXTRUSIONS



PHOTO	CODE	NAME	DESCRIPTION	UNIT QUANTITY
	AZ4025	Aluminium High Z Angle - 6m 	Used in the construction of the cassette, mechanical fix installation method. Grade: 6060/6063 Temper: T5 Thickness: 1.6mm	20
	AZ2310	Aluminium Low Z Angle - 6m 	Used in the construction of the cassette, mechanical fix installation method. Grade: 6060/6063 Temper: T5 Thickness: 1.6mm	20
	AR3819	Aluminium Stiffener - 6m 	Used to stiffen the aluminium panels - attached to the rear side. Grade: 6060/6063 Temper: T5 Thickness: 1.6mm	20
	AL3203	Aluminium Angle - 6m 	Corner reinforcement for cassette systems. Grade: 6060/6063 Temper: T5 Thickness: 3mm	20

\*The use of these accessories needs to be checked for compliance on your project

## CAULKING

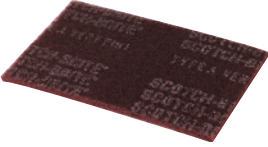

PHOTO	CODE	NAME	DESCRIPTION	UNIT QUANTITY
	CAM41B	Admil Prosil 41LM - Black - 600mL Sausage	A low modulus, high movement, matt finish silicone, designed for cladding expansion joints.	20
	CAM41W	Admil Prosil 41LM - White - 600mL Sausage	A low modulus, high movement, matt finish silicone, designed for cladding expansion joints.	20
	CAM41G	Admil Prosil 41LM - Grey - 600mL Sausage	A low modulus, high movement, matt finish silicone, designed for cladding expansion joints.	20
	CBR016	Open Cell Backing Rod - 16mm x 150mm	Joint filler and sealant backer for cassette installation method.	1 Roll -or- 20 Rolls

## FIXINGS



PHOTO	CODE	NAME	DESCRIPTION	UNIT QUANTITY
	FW1016	Self Drilling Wafer Tek Phillips 10-16 x 16mm	For fixing Z angles to top hats and attaching Top Hats to building. Class 3 Galvanised	Box of 1000
	FR48	4.8mm x 11.4mm Pop Rivets	For fixing Z angles to aluminium façade panels. Aluminium	Box of 1000

\*The use of these accessories needs to be checked for compliance on your project

## TAPES

PHOTO	CODE	NAME	DESCRIPTION	UNIT QUANTITY
	T3M4991	3M™ VHB™ Tape 4991F	12mm x 33m Used to affix stiffeners to the rear of the panel in cassette systems.	9
	T3M7447	Scotch-Brite™ 7447 Maroon Hand Pads	Used to scour the surface prior to the applying tape.	60
	T3M946	3M™ Tape Primer 94 (946mL)	Used to prime the surface on the back of the panel prior to applying 3M™ VHB™ tape.	1

## CLEANING

PHOTO	CODE	NAME	DESCRIPTION	UNIT QUANTITY
	C3MH300	3M™ Hipa Clean 300	Used to clean the surface prior to priming and applying contact adhesives including tape. Also used to remove stronger surface contaminants.	12
	C3MH700	3M™ Solvent 700	Versatile general use solvent ideal for cleaning heavily contaminated surfaces prior to bonding, removes old adhesive residue, grease or previously bonded parts non-damaging to most surfaces.	12

\*The use of these accessories needs to be checked for compliance on your project

## **DISCLAIMER**

---

While the information provided relating to Fairview Architectural products is true to the tests and measures available to us, the information provided in this article is general in nature only and does not constitute project-specific building, construction or fire-safety advice. Before acting on any information on this document, you should consider the appropriateness of the information having regard to your project parameters and requirements. Fairview products are deemed suitable or compliant after approval from building and construction professionals associated with specific projects and developments. If you'd like some further insight about this topic, contact Fairview on 1800 007 175 or email [helpdesk@fv.com.au](mailto:helpdesk@fv.com.au). We're here to see how we can help.



FAIRVIEW™

DEFINING ARCHITECTURE SINCE 1968

AUSTRALIA / NEW ZEALAND / UNITED KINGDOM  
SALES ENQUIRIES 1800 007 175 [HELPDESK.AU@FV.COM.AU](mailto:HELPDESK.AU@FV.COM.AU)

MARCH 2020