

Discrete Job Pick List

Job: CM589832 Status: Released
 Assembly: CMRS9107443 RUBBER/SPRING SEALS
 FLUOROCARBON FR25/90 INTERNAL WITH STAINLESS
 STEEL SPRING(S) ID 548.64MM S 10.15MM DP 12.7MM
 DRAWING NO. JWC-FP-207864 REV.-

Planner: CM Planner
 Scheduled Quantity: 10

Start Date: 11/04/15
 Completion Date: 16/04/15

Class: DEFAULT
 Supply Type: Push

Schedule Group:

Build Seq:

Component	Op Seq	Date Required	Supply Subinv	Supply Locator	Supply Quantity	Quantity Open	UO M	On Hand Subinv	On Hand Locator	Quantity On Hand
RMPE3049413	5	11/04/15	CMDWPEX	CMDWPEX. UNDEF		17.55	M			0
FLUOROCARBON FR25/90 JW SPEC 200 187 ISS. 7 MISC DRAWING NO. JWC-FP-207864 REV.- LENGTH 1.795M DIE 641-149 WEIGHT 412G										
RMPE1022997	5	11/04/15	CMDRMNR	CMDRMNR. SP.BIN.2		35.75	EA	CMDRMNR	CMDRMNR.SP.BI N.2	3013.194
STAINLESS STEEL BS EN 10270-3-1.4401 (FORMER DESIGNATION BS2056:1991 GRADE 316 S42) SEMI OPEN COIL SPRING DS 2.4MM DRAWING NO. JW 175813-2 ISS. B PER METRE										

DRAWING NUMBER	REVISION
JWC-FP-207864	-

**CUSTOM MOULDING
INTERNAL RUBBER/SPRING SEAL
MATERIAL: FR25/90**

CUSTOMER DRAWING No.
599515-18-87-05 REV.01

INSPECT TO JW STD 200 070

TOLERANCES IN ACCORDANCE
WITH BS ISO 3302-1:2014
CLASS M2 F & C

TOOLING:
MLD No. JWC-PM-207864

SPRINGS IN ACCORDANCE
WITH JW 175813-2

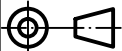
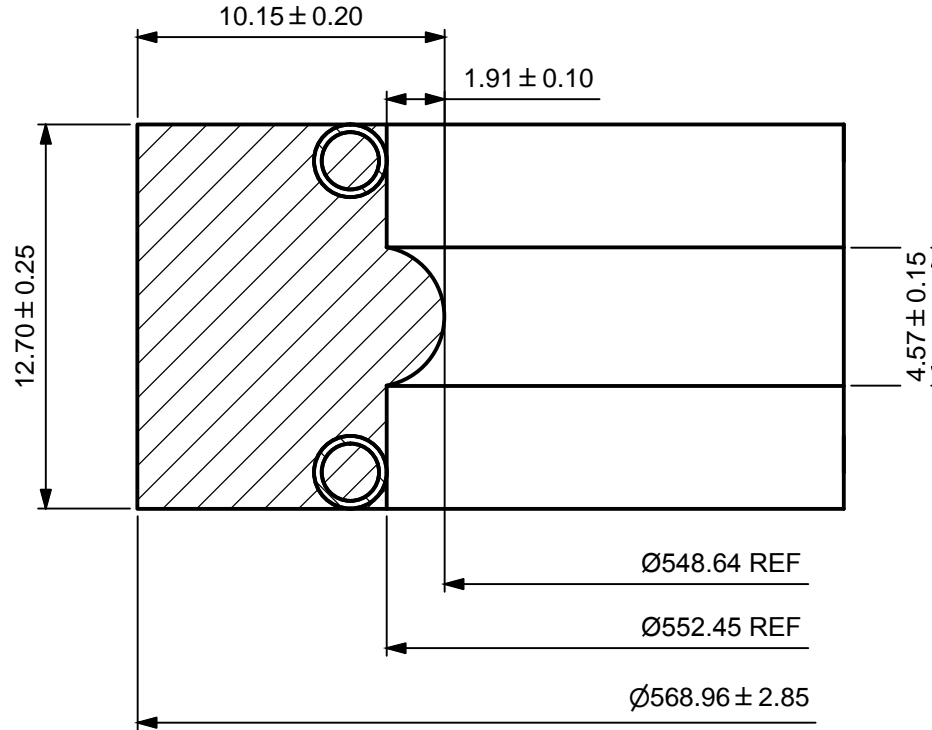

IF IN DOUBT - ASK!	PAPER SIZE: A4	SCALE: 4 : 1	JW PART NUMBER	JW TECHNICAL REFERENCE	TITLE					
ALL DIMENSIONS IN MILLIMETRES UNLESS OTHERWISE STATED			CMRS9107443	-	INTERNAL RUBBER/SPRING SEAL					
ALL ORDERS SUBJECT TO OUR CONDITIONS OF SALE			JW SITE REFERENCE	CUSTOMER REFERENCE						
THIS DRAWING CONTAINS INFORMATION WHICH IS THE EXCLUSIVE PROPERTY OF JAMES WALKER & CO LTD. IT MUST NOT BE DISCLOSED TO A THIRD PARTY OR USED FOR MANUFACTURING PURPOSES WITHOUT WRITTEN AUTHORISATION BY THE OWNER.			COCKERMOUTH	JAMES WALKER OIL & GAS CO						
			James Walker & Co Ltd Gote Brow, Cockermouth, Cumbria, CA13 0NH, United Kingdom. Phone: +44 (0)1900 823555 Fax: +44 (0)1900 898354 Web: www.jameswalker.biz		James Walker	ORIGINAL	NAME	DATE	DRAWING NUMBER	REVISION
© James Walker & Co Ltd 2014 AND AMENDMENTS AS DATED					DESIGNER	-	-	JWC-FP-207864	-	1 / 1
					DRAWN	SARAH BELL	04/12/2014			
					CHECKED	<DRG IPROPERTY 2>				

This copy will not be updated - destroy after use