

Reprinted with permission from: GPC-14 Annual Report: Leafy Spurge Control in the Great Plains. 1981. pp. 30-31.

Published by: Great Plains Agricultural Committee.

A pipe-wick herbicide applicator for perennial weed control in pastures

CALVIN G. MESSERSMITH and RODNEY G. LYM

Department of Agronomy, published with the approval of the Agriculture Experiment Station, North Dakota State University, Fargo, ND.

A pipe-wick applicator was designed to provide a greater herbicide flow rate than rope-wick applicators for perennial weed control experiments in pastures. The pipe-wick was mounted on a frame so a tractor 3-point hitch could be used for height control (Figure 1). Two wick bars were spaced 1 ft apart for double coverage of the weeds. The pipe-wick consists of 0.75 inch PVC pipe with 0.12 inch holes drilled every 2 inches and covered with a wicking material (Figure 2). The wicking material was wrapped around about 75% of the pipe circumference and attached to the PVC pipe with contact cement. Liquid in the storage tank flows into the wick with flow rate dependent on weed density. A preliminary screening of 20 wick materials to cover the PVC pipe was conducted in the lab and greenhouse. Materials were evaluated according to ability to transfer (wick) herbicide onto plants, resistance to dripping, durability, and ease of obtaining material.

Four materials were chosen for the field study: canvas (50% cotton-50% polyester) over 1-inch wide by 0.5 inch thick polyfoam; Nylafoam, a polyfoam material covered with 0.25-inch bristles used to paint shake shingles (Padco Inc.) Minneapolis, MN); dacron (G7 plain weave fabric #718 from Testfabrics, Inc., Middlesex, NJ) over 1-inch wide by 0.5-inch thick polyfoam; and a fabric belt, 1.5 inches wide. The field experiment was established on June 20, 1980 near Sheldon, ND when leafy spurge was fully flowered and 20 to 26 inches tall. Picloram (Tordon 22K):water solution concentrations of 1:7, 1:11, and 1:15 (v:v) were applied using 3 ft wide rectangular wicks. Plots were 5 by 30 ft and replicated four times in a randomized complete block design. Evaluations on May 29, 1980 were based on percent stand reduction as compared to the control.

Wick Material	Picloram Concentration			Mean
	1:7	1:11	1:15	
	(% control)			
Canvas	13	12	5	10
Nylafoam	63	38	17	39
Dacron	6	5	4	5
Fabric belt	0	0	2	0
Mean	21	13	7	

LSD (0.05)=Materials=8; Conc.=7; Material x Conc.=12

Nylafoam was the most effective material for wicking picloram onto leafy spurge. However, field observations revealed that Nylafoam was easily torn by woody stems and shrubs commonly found in pastures. The canvas with polyfoam backing was chosen for further evaluation, because it seemed durable and tended to provide better control than the dacron material. The fabric belt was unacceptable as a wicking material.

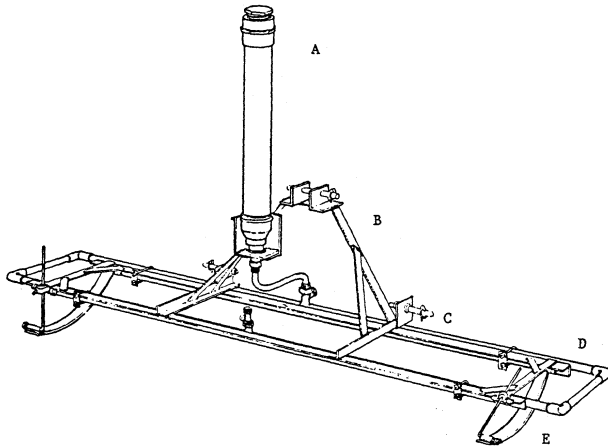

Figure 1. Pipe-wick herbicide applicator and frame with:

- (A) storage tank,**
- (B) 3-point hitch assembly.**
- (C) angle iron frame,**
- (D) 0.75-inch PVC pipe held to frame by U-clamps, and**
- (E) skids for height control.**

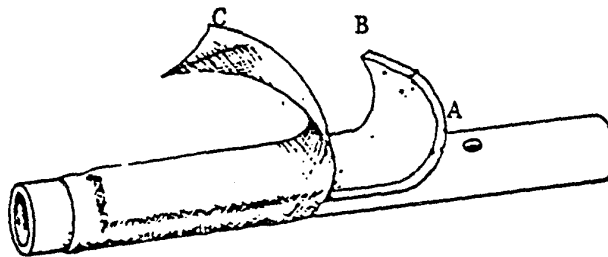

Figure 2. Bottom view of a section of the pipe-wick applicator showing:

- (A) 0.12 inch holes covered by**
- (B) 0.5 inch polyfoam covered by**
- (C) canvas.**