

## RESET AND CLOCK GENERATORS

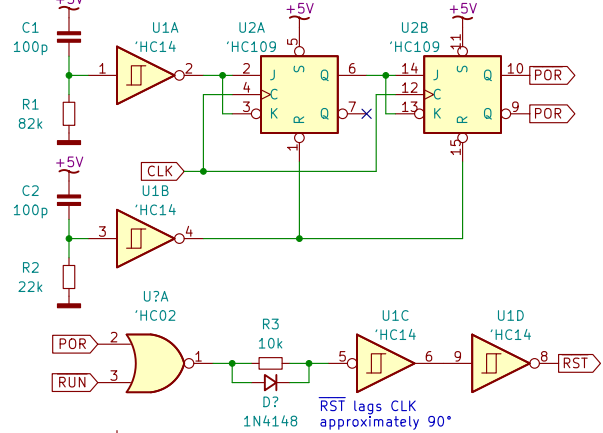

## DOT COUNTER and POSCLK GENERATOR

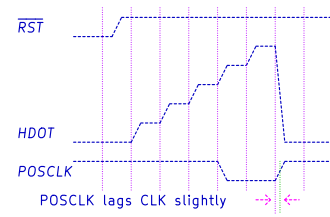
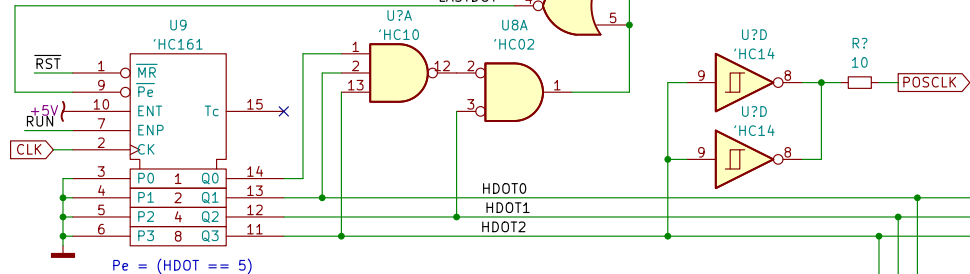

## HORIZONTAL DAC

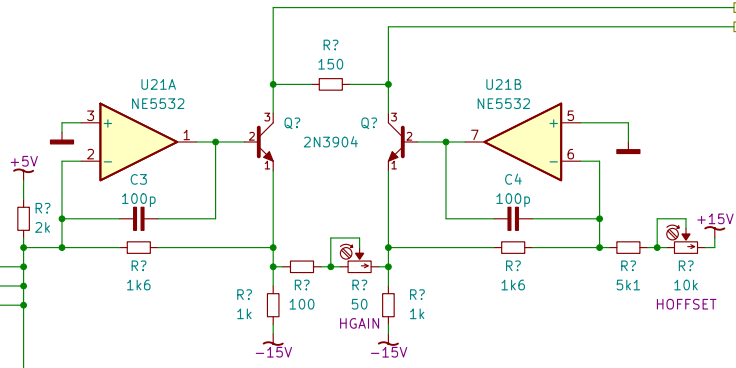

TODO: add one more dot between chars

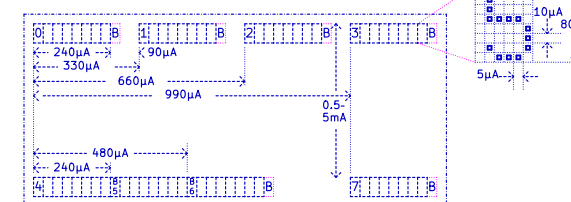

## START/DONE CONTROL

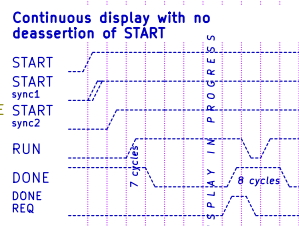
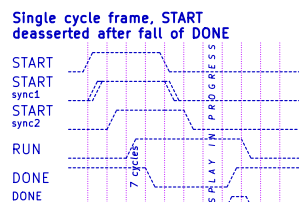
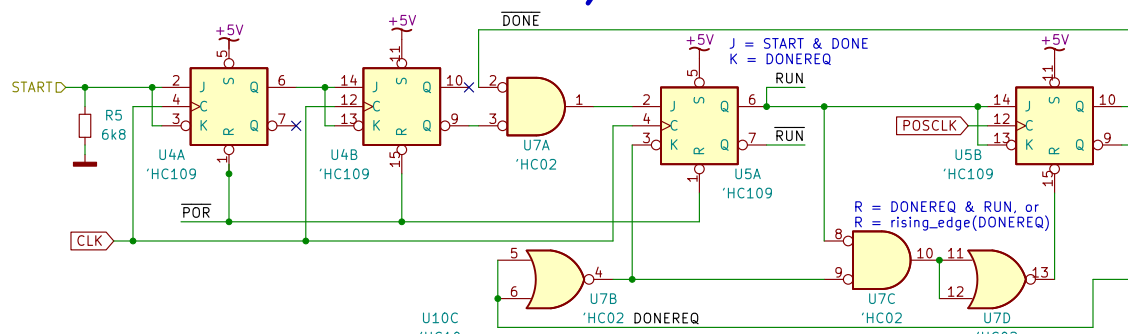

## VERTICAL DAC

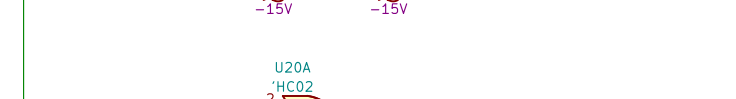
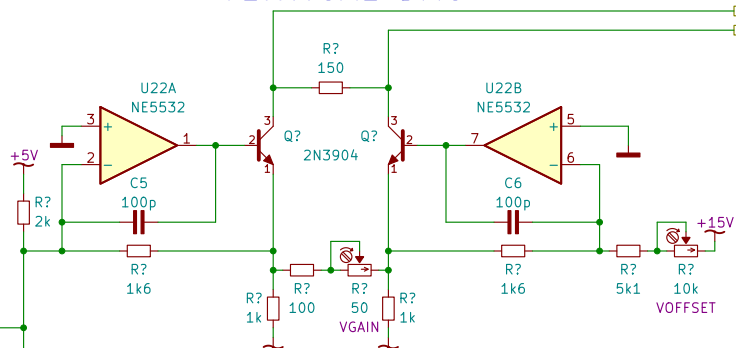

## SEQUENCE COUNTERS

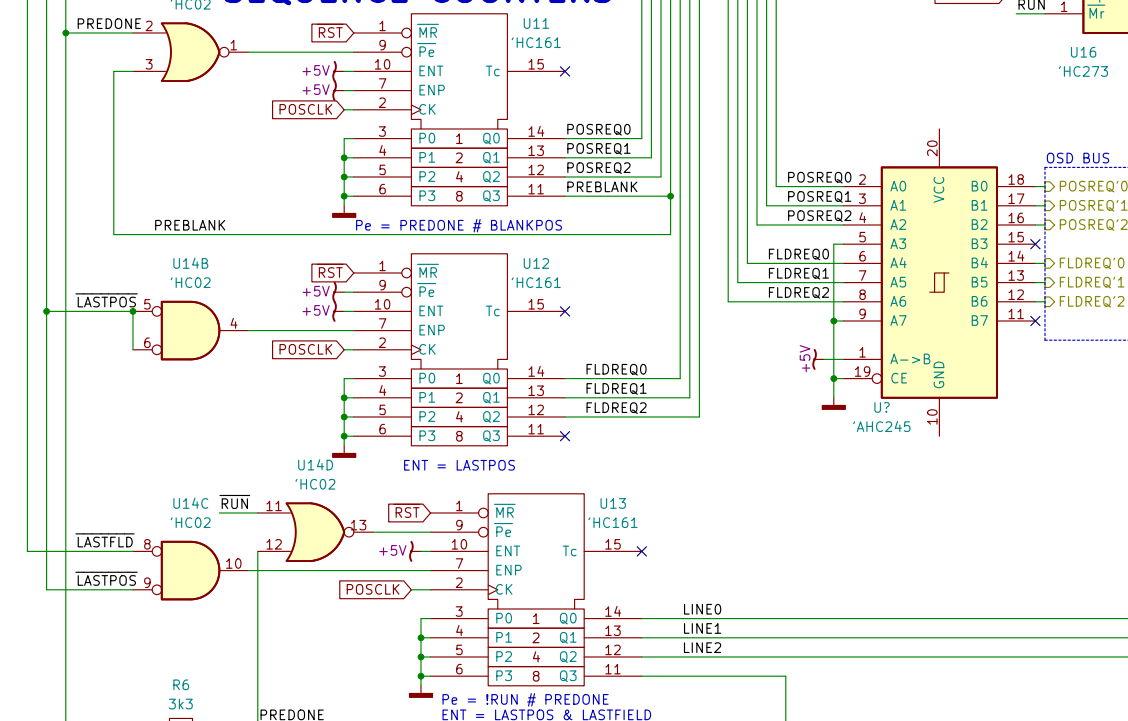

## FONT ROM

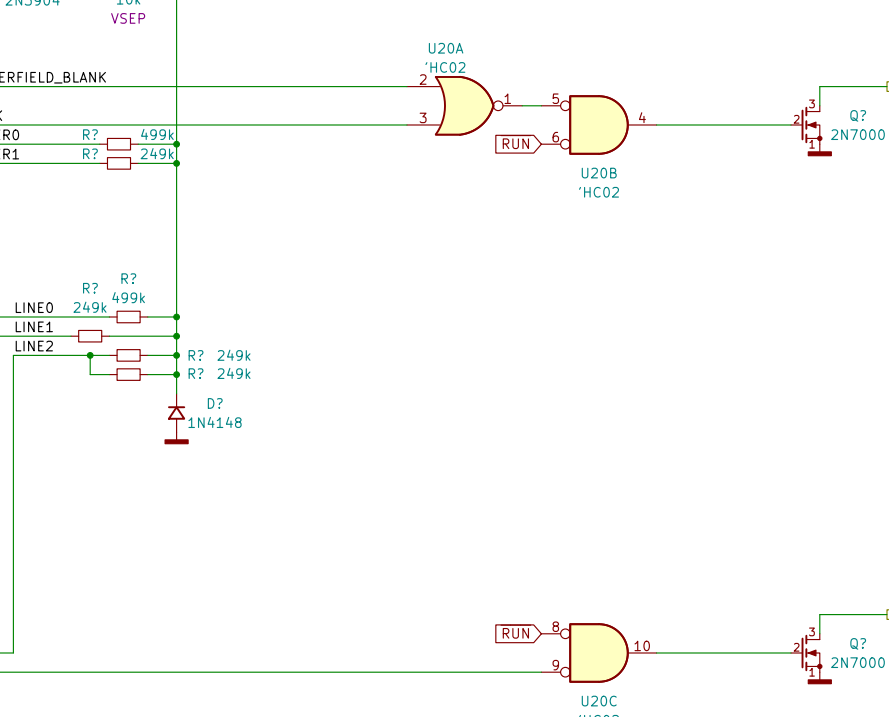
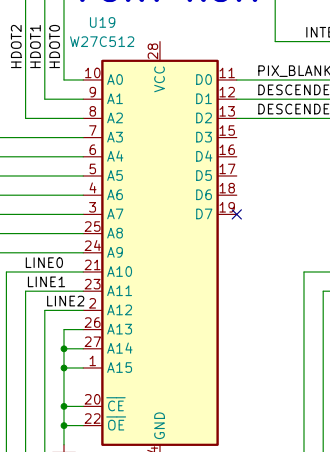

Direction of clock distribution

