

Synopsis of

Standard Format for Preparing the Synopsis

A THESIS

submitted by

M.S STUDENT'S NAME

for the award of the degree

of

MASTER OF SCIENCE

(by Research)



**Department of Electrical Engineering
Indian Institute of Technology Madras, India.**

January 2009

1 Introduction

Outline, briefly, the technological / engineering / scientific relevance or significance of the research work to be reported in the thesis in this section. Introduction can at the best occupy one page, preferably one paragraph occupying half a page. Be precise and include only relevant background material in the introduction. Provide information on past works by way of giving appropriate references. For the cover page, the title of the synopsis must be the same as the title of the thesis. Use "times roman" 20 font, bold faced and centered paragraph style. For typing the name of the student and the name of the degree, use font size 14, bold faced type and centered paragraph style. For typing the department name, use 18 point size, bold faced and centered paragraph style. Use the correct emblem. Do not use an emblem with double circles or double line for the flame! Use "times roman" font size 12, double line spacing and justified paragraph style for normal text. Every figure (diagram, table and graph too) must be embedded along with the text and appear immediately after the first time the figure is referred to in the text. Each figure (diagram, table and graph) must be given a number and a proper title. Use IEEE notation (examples are given here). Each figure must be referred in the text. Make the figure legible and provide enough information so that the figure is "self contained". Provide legible legends that correctly describe the axes of a graph. Fig. 1 is an example showing a photograph. Fig. 2 is an example showing a circuit schematic. Use SI symbols, units and notations. If more

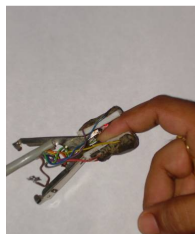

Figure 1: PPG Sensor head

than one curve is presented in a graph make sure each one is correctly identified. You can use this document which is a word template to type in or format your synopsis. Fig. 3 is another

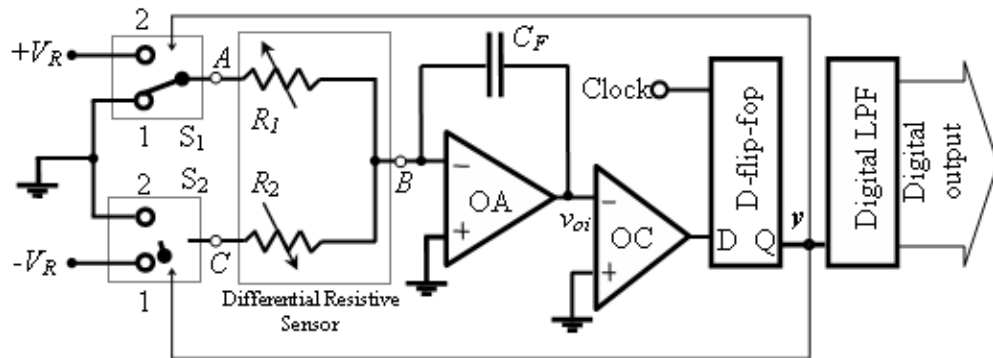

Fig. 2 Proposed sigma-delta resistance to digital converter

example showing the depiction of a waveform. The example of a table is given in Table 1. Fig. 4 is an example of a graph.

Table 1 Error in reconstructed PPG for a chosen number of Fourier coefficients.

No. of Coefficients	NRMSE	
	dB	%
1	-17.60	13.19
2	-27.96	4.00
3	-33.89	2.02
4	-44.42	0.60
5	-44.59	0.59
6	-44.82	0.57
7	-45.85	0.51
8	-45.90	0.51
9	-45.96	0.50
10	-46.28	0.49

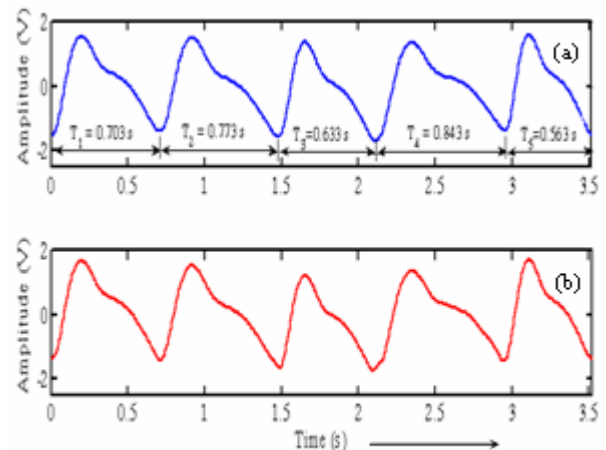

Fig. 3 (a) Sample PPG chosen.(b) PPG extracted with only the first 7 Fourier coefficients.

The synopsis can have at the maximum 16 pages, including the cover page and should be printed on both sides of the paper. The paper must be A4 size with the following margins: Top, bottom and right margins must be 2.1 cm each. Left margin should be 3.0 cm. If there are colour illustrations either print the page in colour or make the illustrations "black and white friendly". You should also provide a soft copy of the synopsis.

2 Motivation

In this section, develop further on the background material provided in the introduction and bring the state of art in the chosen area of research. Should clearly indicate the existing

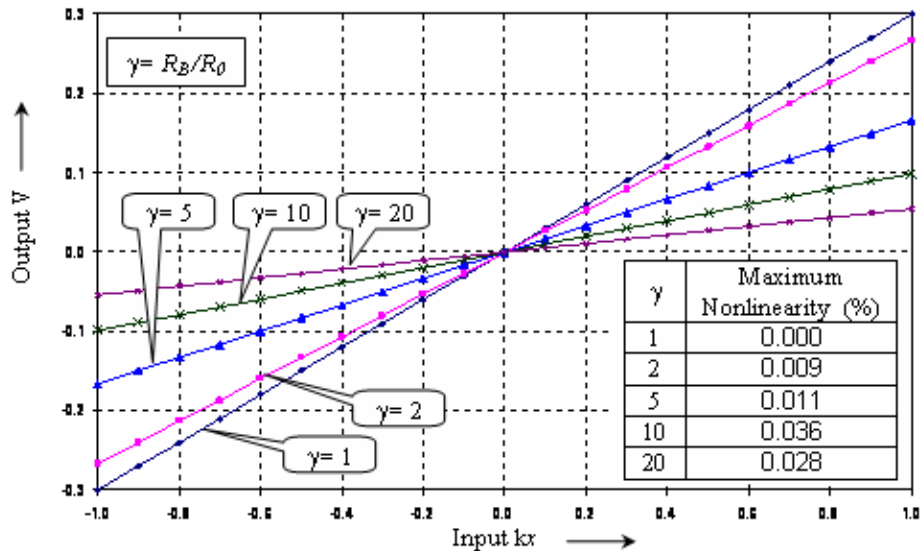

Fig. 4 Simulated Output of the single active sensor Wheatstone bridge – with the proposed feedback compensation

drawbacks and why further research is required to eliminate the drawbacks. Emphasize, based on the current status, the importance of the research problem identified. You can enumerate those technical challenges one has to address to solve the problem(s) posed herein to place emphasis on the quality of the research work. Maximum one page, preferably half a page be allotted to this section.

3 Objectives and scope

State clearly the questions for which answers are sought through this research. Define the conceptual, analytical, experimental and/or methodological boundaries within which the exercise has been carried out. Maximum one page, preferably half a page can be allotted to this section.

4 Description of the research work

In this section, give brief, but sufficient details regarding (a) the research problem(s) (b) the solution methodologies adopted or invented and brief details of simulation studies and / or experiments conducted. Provide interpretation of the results. You may have subsections (4.1, 4.2) here. Restrict the sections to less than 10 pages.

5 Conclusions

Highlight major (and not all) conclusions. Clearly bring out not only advantages arising out of the work to be presented in the thesis but also give limitations of the work. If there are no conclusions to be drawn, then enumerate the contributions of the work and change the title of this section to **Summary of the work**. If you follow meticulously all the instructions given herein you will produce a "good synopsis". Please note if the synopsis is written well, a prospective examiner will not hesitate to say "yes" to review the proposed thesis. It is recommended that you write the synopsis after writing the thesis (at least the first draft).

6 References

List the references in the same order as they are referred to in the synopsis make sure all references listed here are properly referred in the text. Restrict the number of references to less than ten. Use IEEE format. The font for references should be times roman 10 with single line spacing and paragraph formatting to be used is "hanging" with Justified. Examples are given below. Please note that reference [1] is a book, [2] is a patent, [3] is a journal article, [4] is an article published in a conference proceedings and [5] is a web page.

REFERENCES

- [1] E. O. Doebelin, "Measurement Systems - Application and Design", 5th ed., McGraw-Hill, New York, 2004.
- [2] J. K. Gustafsson, "Analog-digital converter for a resistance bridge", Patent U. S. 3960010, June 1, 1976.
- [3] B. Wang, T. Kajita, T. Sun and G. C. Temes, "High-Accuracy Circuits for On-chip Capacitive Ratio Testing and Sensor Readout", IEEE Trans. Instrum. & Meas., Feb. 1998, vol.47, no.1, pp. 16-20.
- [4] V. J. Kumar, N. M. Mohan and V. G. K. Murti, "Digital Converter for Push-pull type Resistive Transducers", Proc. IEEE IMTC 2005, Ottawa, Canada, May 17-19, 2005, pp.422-425.
- [5] Data Sheet, PIC16F87XA, "28/40/44-Pin Enhanced Flash Microcontrollers", Microchip Technology Inc., 2003. <http://ww1.microchip.com/downloads/en/DeviceDoc/39582b.pdf>

7 Proposed contents of the thesis

In this section provide only the Chapter and Section titles of the proposed thesis. Maximum one page only can be allotted for this section of the synopsis.

8 List of Publications based on the research work

List the publications arising out of the research work. Give complete details. Use IEEE format (vide reference section for examples). List only published or accepted papers. You may include papers under review. Do not include "papers under preparation". List International Journal publications first, followed by National Journal articles, International Conference articles and lastly articles presented in National Conferences. Patents arising out of the work can be included here.